

3/18/2022 11:06:44 AM G:\Projects\2020\Division 6 (Mott) Mac - NV5\I-5987B\Structures\Site 9 (L over Little Marsh Swamp)\Drawings\Final\I5987B_SMU_B1_770164.dgn

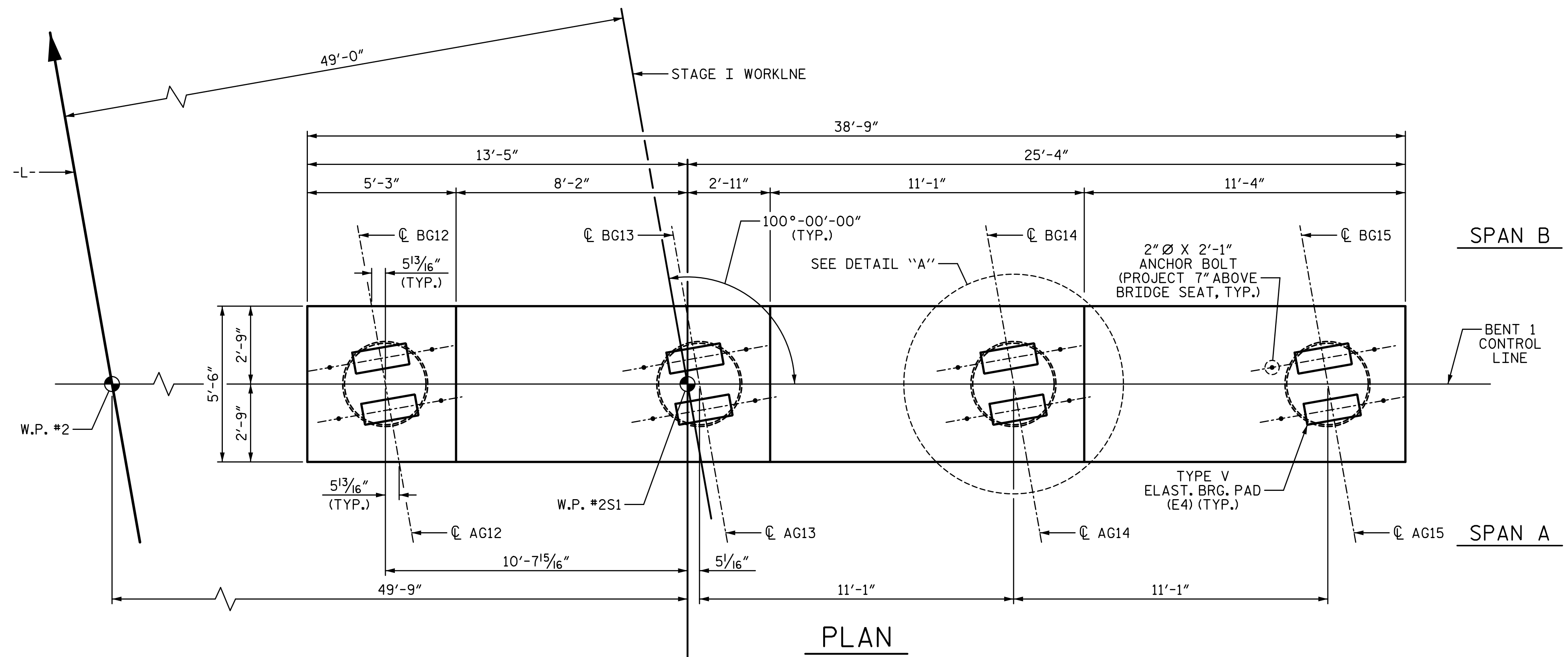

NOTES:

STIRRUPS IN CAP MAY BE SHIFTED AS NECESSARY TO CLEAR ANCHOR BOLTS.

* INVERT ALTERNATE STIRRUPS.

FOR ADDITIONAL REINFORCING STEEL IN PP 36 X 0.75 GALVANIZED STEEL PILES, SEE 36" STEEL PIPE PILE SHEET.

GALVANIZE THE TOP OF EACH INTERIOR BENT PILE A MINIMUM OF 33 FEET. GALVANIZE IN ACCORDANCE WITH SECTION 1076 OF THE STANDARD SPECIFICATIONS.

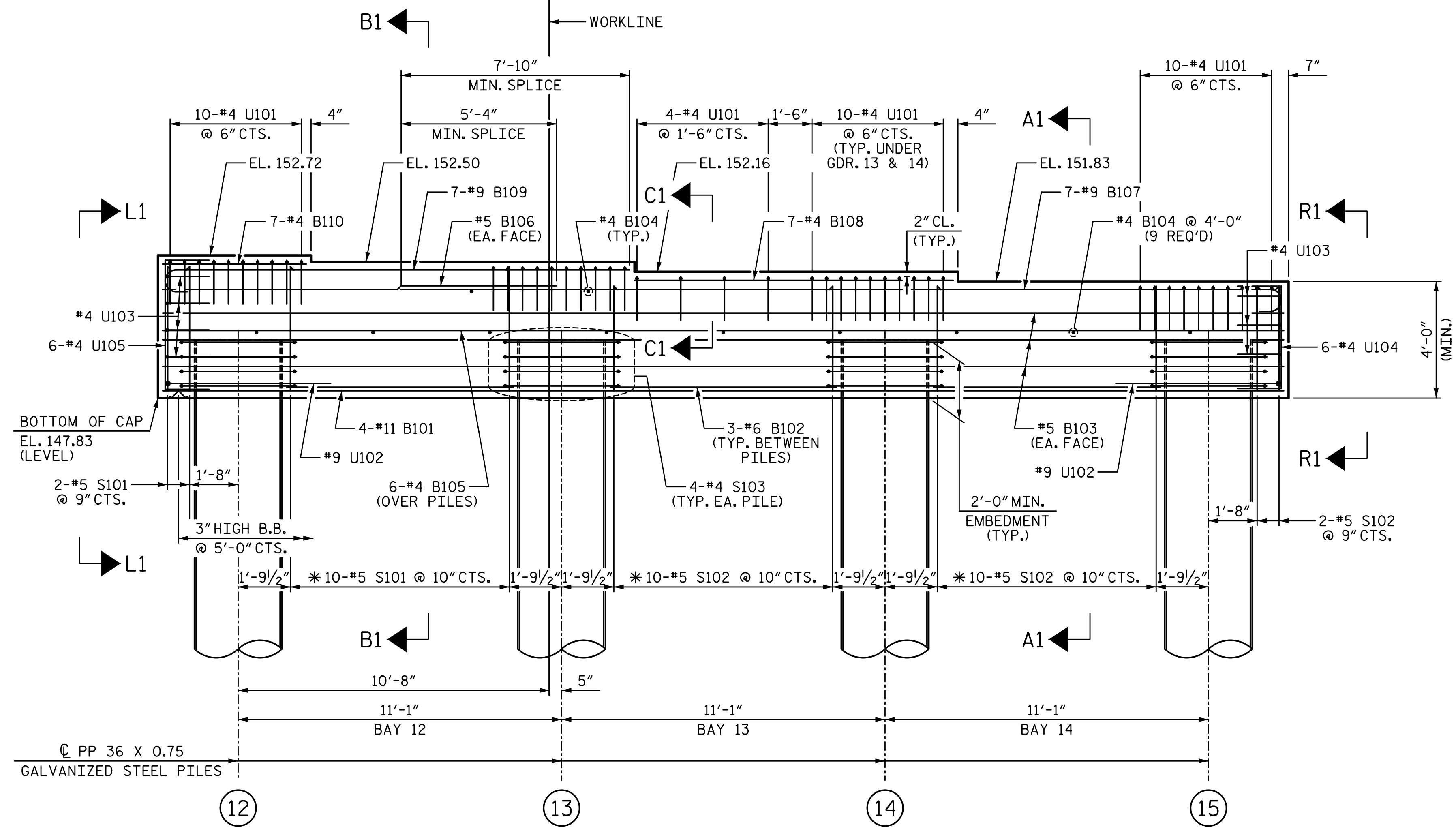
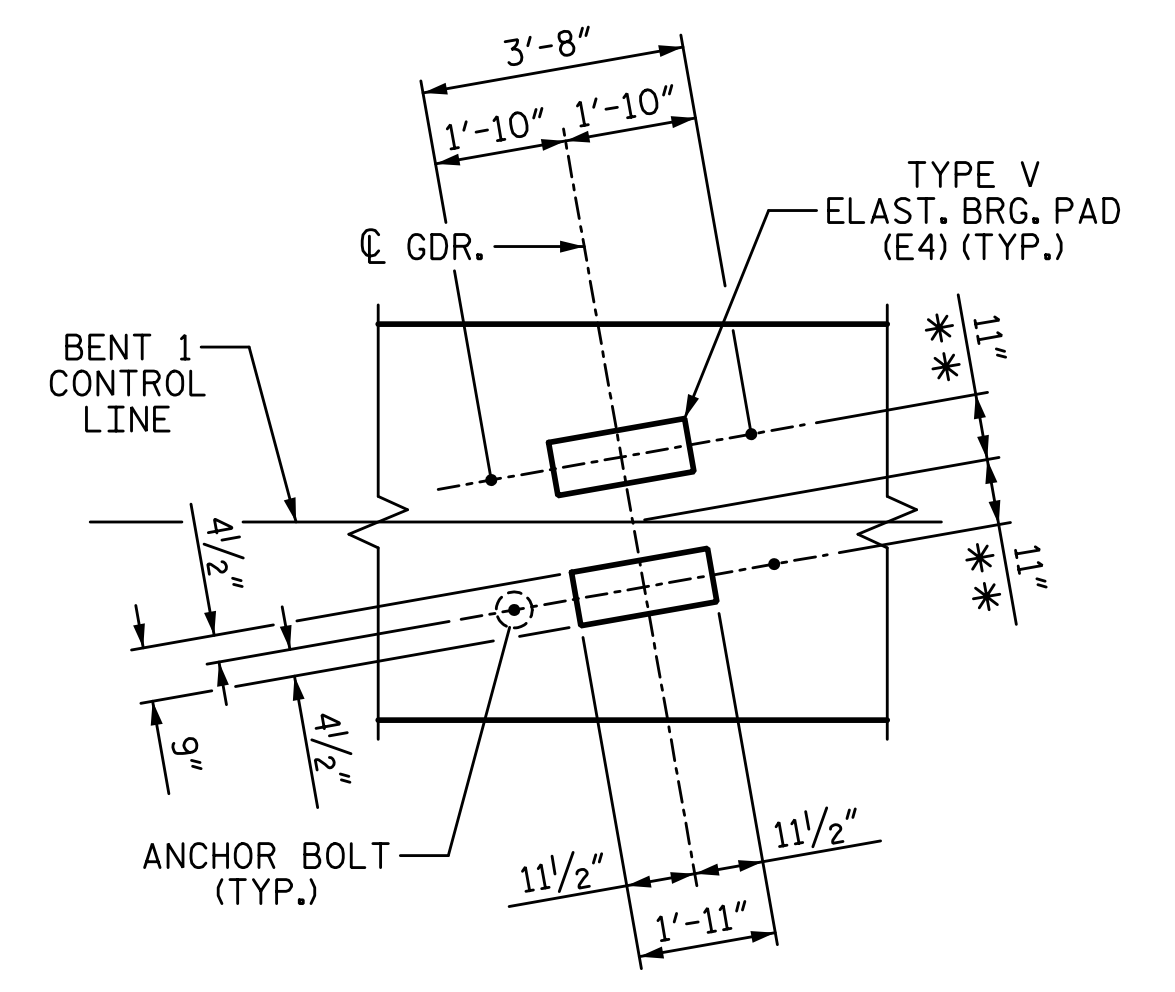

PROJECT NO. I-5987B

ROBESON COUNTY

STATION: 803+15.00 -L-

SHEET 1 OF 6

STATE OF NORTH CAROLINA
DEPARTMENT OF TRANSPORTATION
RALEIGH
SUBSTRUCTURE

BENT 1

STAGE I

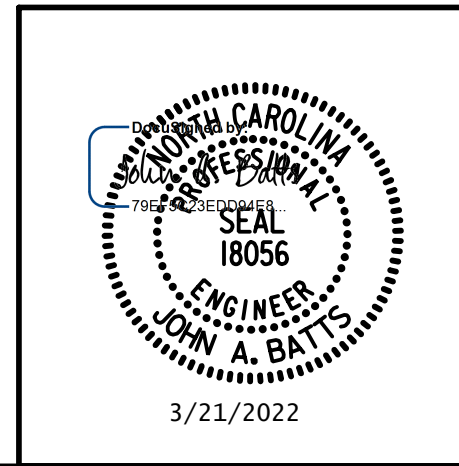

DRAWN BY: T. BANKOVICH DATE: 3-22

CHECKED BY: J.A. BATTIS DATE: 3-22

DESIGN ENGINEER OF RECORD: J.A. BATTIS DATE: 3-22

⊙ INDICATES PILE NUMBER

REVISIONS						SHEET NO.
NO.	BY:	DATE:	NO.	BY:	DATE:	S9-51
1			3			TOTAL SHEETS
2			4			69

**DOCUMENT NOT CONSIDERED FINAL
UNLESS ALL SIGNATURES COMPLETED**