

3/18/2022 11:06:16 AM G:\Projects\2020\Division 6 (Mott Mac - NV5)\I-5987B\Structures\Site 9 (L over Little Marsh Swamp)\Drawings\Final\I5987B\_SMU\_TS\_770164.dgn

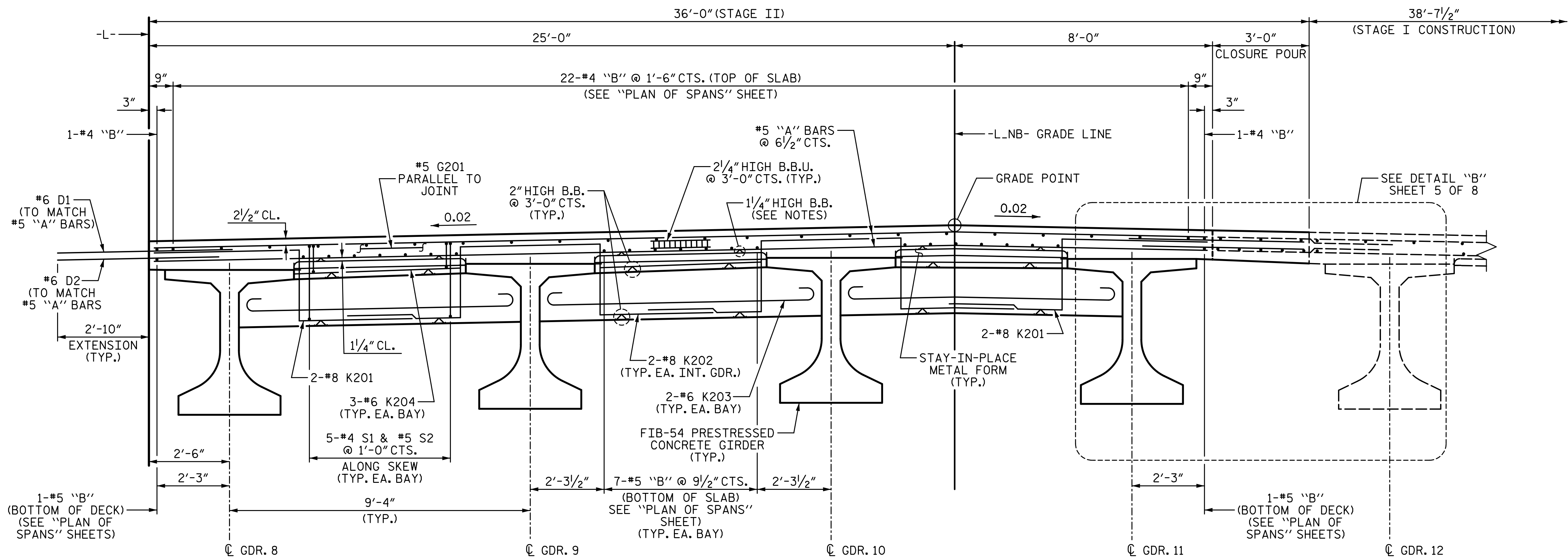

**TYPICAL SECTION**  
(SHOWING END BENT DIAPHRAGMS)

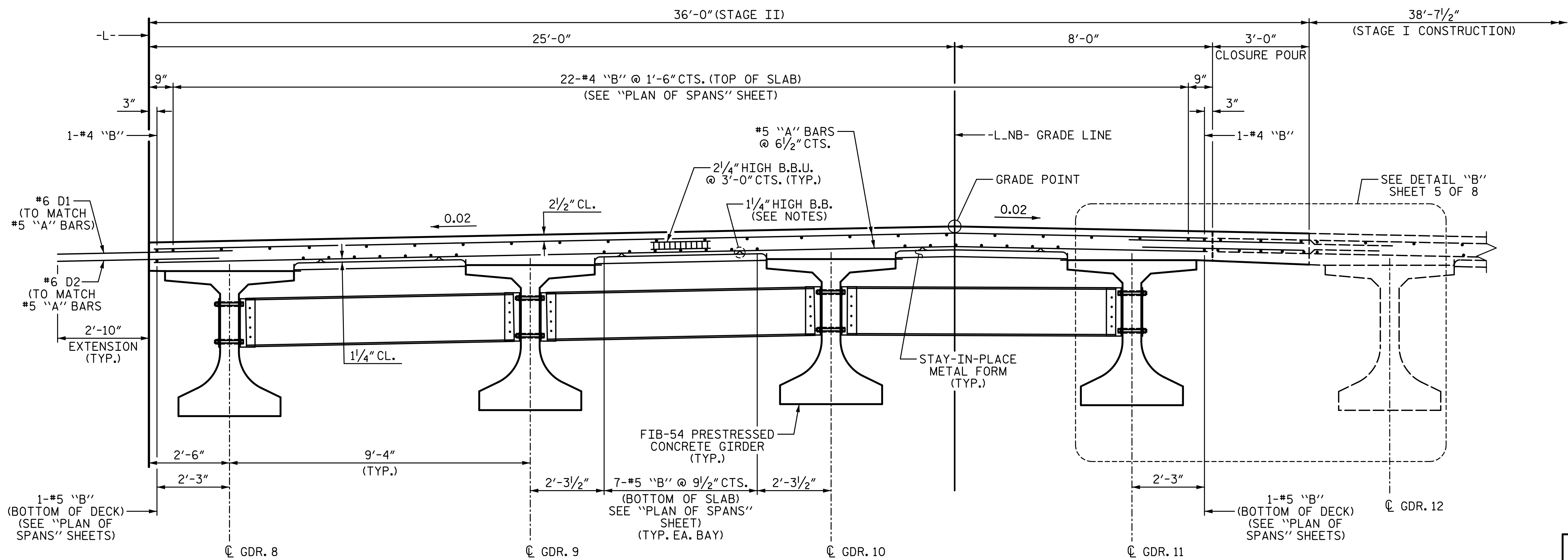

**TYPICAL SECTION**  
(SHOWING INTERMEDIATE DIAPHRAGMS)

PROJECT NO. I-5987B  
ROBESON COUNTY  
 STATION: 803+15.00 -L-  
 SHEET 4 OF 8

STATE OF NORTH CAROLINA  
 DEPARTMENT OF TRANSPORTATION  
 RALEIGH  
 SUPERSTRUCTURE  
**TYPICAL SECTION**  
 STAGE II

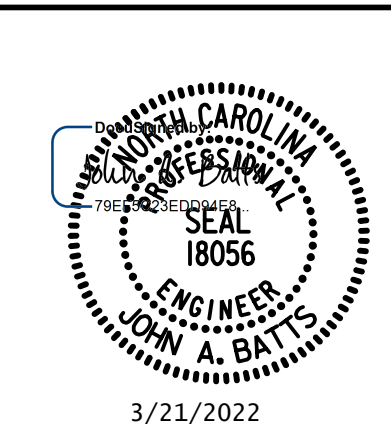

DRAWN BY: T. BANKOVICH	DATE: 3-22
CHECKED BY: J.A. BATTS	DATE: 3-22
DESIGN ENGINEER OF RECORD: J.A. BATTS	DATE: 3-22

REVISIONS						SHEET NO.
NO.	BY:	DATE:	NO.	BY:	DATE:	S9-10
1			3			TOTAL SHEETS
2			4			69

**DOCUMENT NOT CONSIDERED FINAL  
 UNLESS ALL SIGNATURES COMPLETED**