

3/18/2022 11:06:15 AM G:\Projects\2020\Division 6 (Mott Mac - NV5)\I-5987B\Structures\Site 9 (L over Little Marsh Swamp)\Drawings\Final\I5987B\_SMU\_TS\_770164.dgn

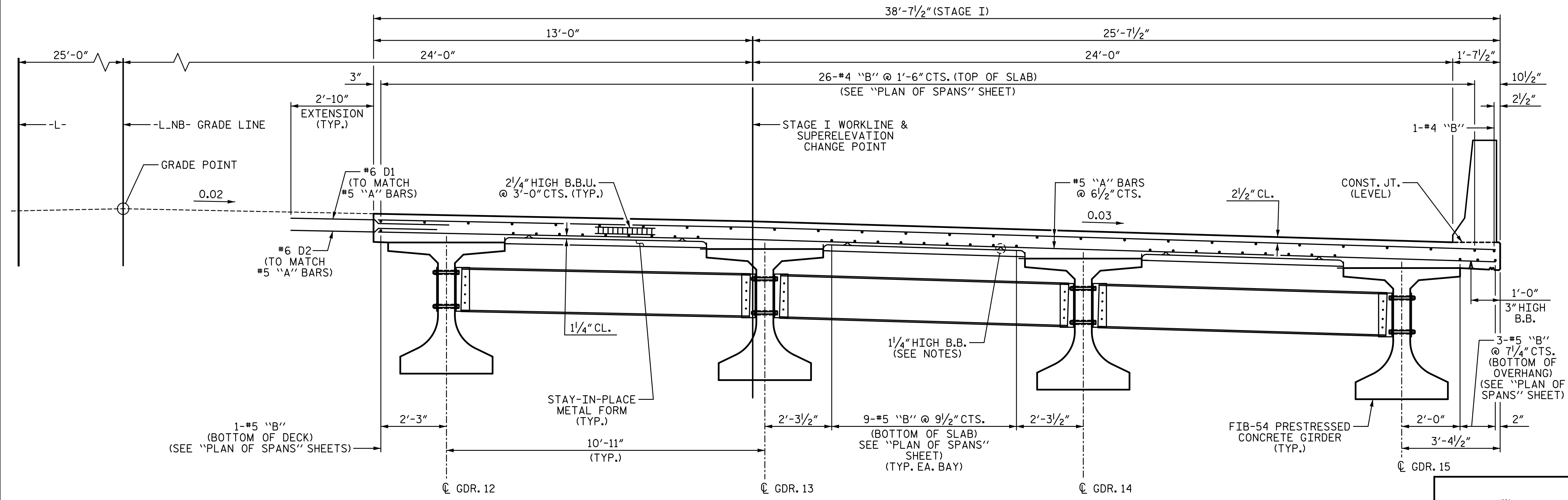
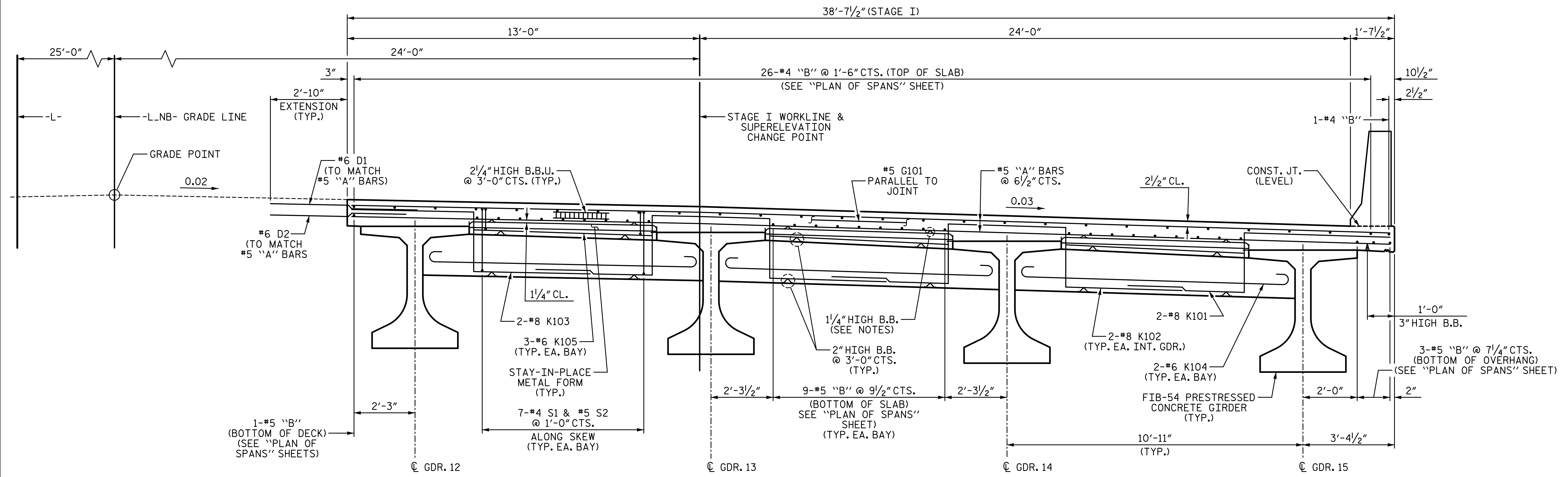

PROJECT NO. I-5987B  
ROBESON COUNTY  
 STATION: 803+15.00 -L-

SHEET 2 OF 8

STATE OF NORTH CAROLINA  
 DEPARTMENT OF TRANSPORTATION  
 RALEIGH  
 SUPERSTRUCTURE

**TYPICAL SECTION**

STAGE I

REVISIONS						SHEET NO.
NO.	BY:	DATE:	NO.	BY:	DATE:	S9-8
1			3			TOTAL SHEETS
2			4			69

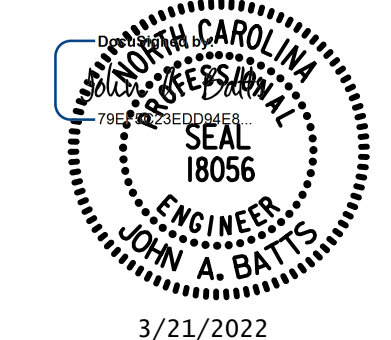

DRAWN BY: <u>T. BANKOVICH</u>	DATE: <u>3-22</u>
CHECKED BY: <u>J.A. BATTS</u>	DATE: <u>3-22</u>
DESIGN ENGINEER OF RECORD: <u>J.A. BATTS</u>	DATE: <u>3-22</u>

DOCUMENT NOT CONSIDERED FINAL  
 UNLESS ALL SIGNATURES COMPLETED