

PLAN @ END BENT 1

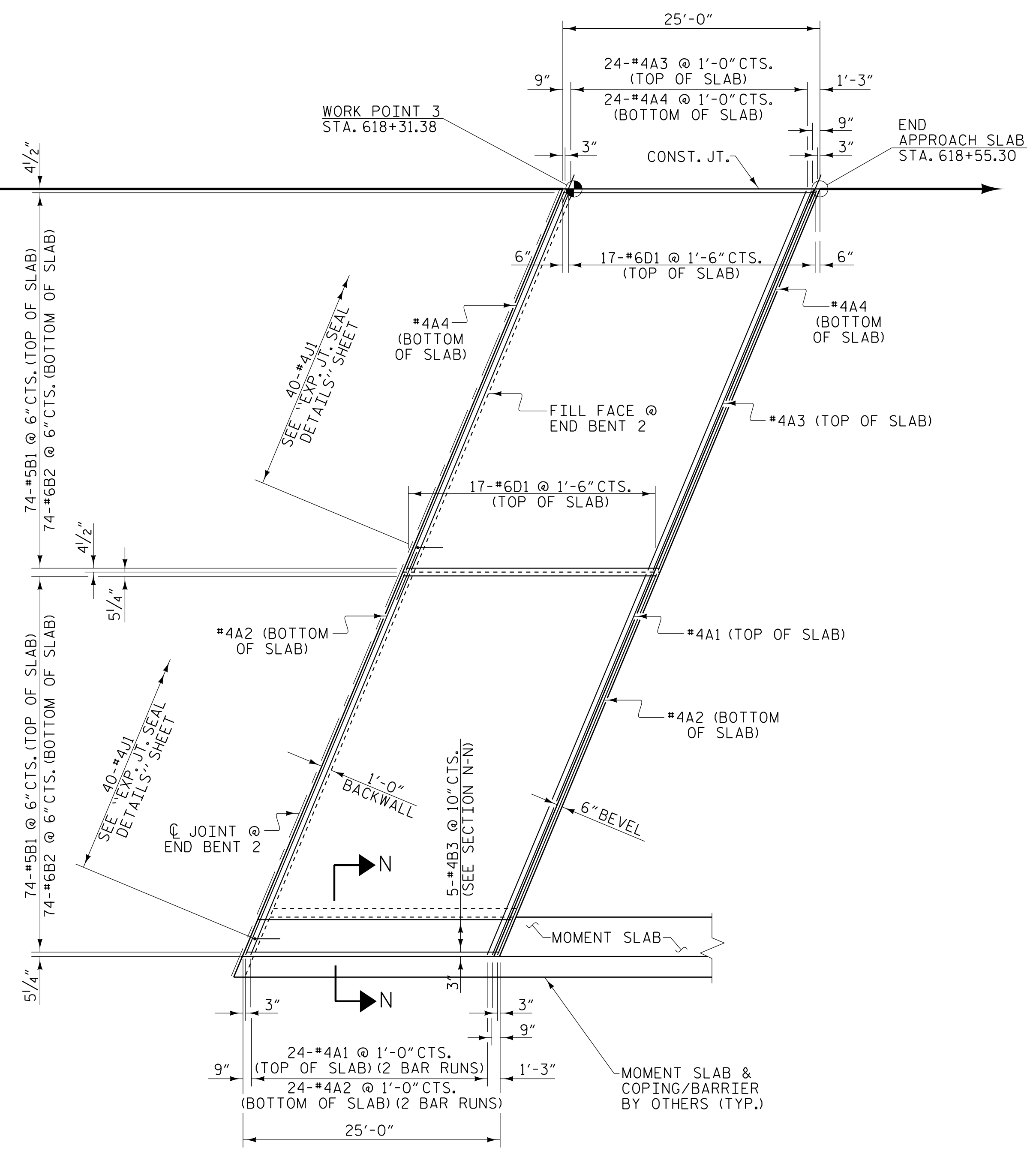

PLAN @ END BENT 2

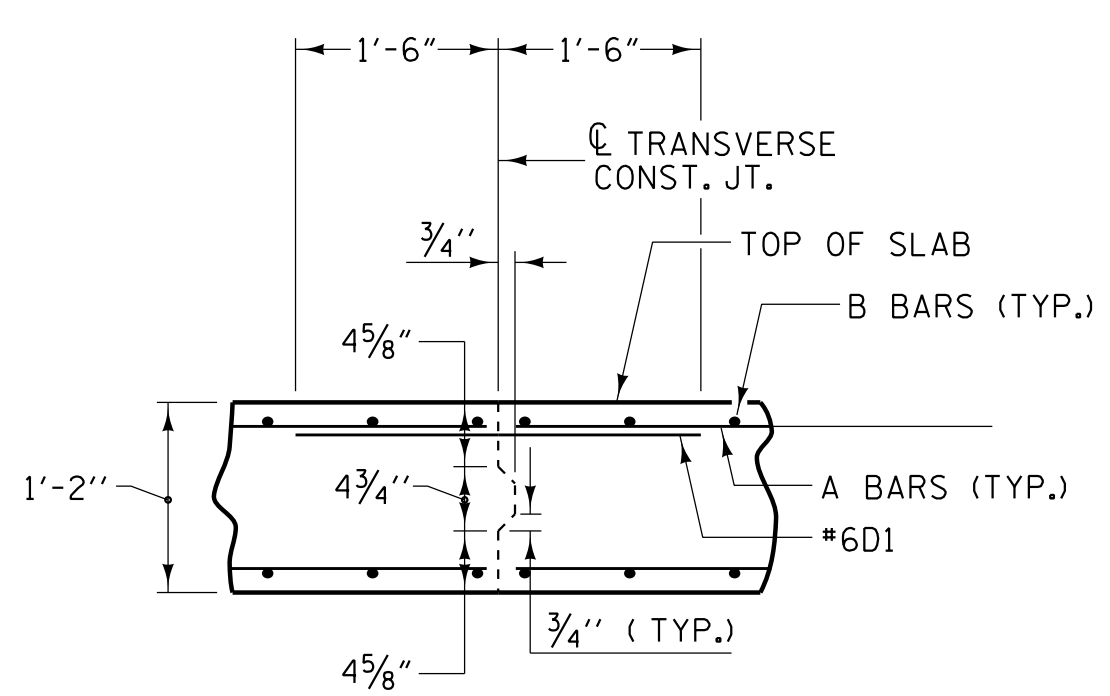

TRANSVERSE CONSTRUCTION JOINT DETAIL

NOTES:
 1. DIMENSIONS ARE TYPICAL FOR BOTH APPROACH SLABS
 2. SEE PLAN OF BRIDGE APPROACH SLABS 3 OF 4 FOR SECTION N-N

DRAWN BY : W.B. ALLEN DATE : 12/21
 CHECKED BY : M.D. METZGER DATE : 12/21
 DESIGN ENGINEER OF RECORD: L. K. AUSTIN DATE : 01/22

PLANS PREPARED BY:
NV5
 NV5 ENGINEERS & CONSULTANTS, INC.
 3300 REGENCY PARKWAY, SUITE 100
 CARY, NC 27518
 P: 919.851.1912 www.NV5.com
 NC License # F-1333



PROJECT NO. I-5987B
 ROBESON COUNTY
 STATION: 617+12.20 -L- POT

SHEET 1 OF 4
 STATE OF NORTH CAROLINA
 DEPARTMENT OF TRANSPORTATION
 RALEIGH
**PLAN OF BRIDGE
 APPROACH SLABS**
 STAGE I & STAGE II

REVISIONS						SHEET NO.
NO.	BY:	DATE:	NO.	BY:	DATE:	TOTAL SHEETS
1			3			53
2			4			

**DOCUMENT NOT CONSIDERED FINAL
 UNLESS ALL SIGNATURES COMPLETED**