

NOTES

STIRRUPS AND "U" BARS IN CAP MAY BE SHIFTED AS NECESSARY TO CLEAR ANCHOR BOLTS.

HOOKS ON "V" BARS MAY BE TURNED AS NECESSARY FOR PLACING REINFORCING STEEL.

LONGITUDINAL REINFORCING STEEL IN THE COLUMN SHALL BE SPLICED USING MECHANICAL BUTT SPLICES WHERE SHOWN IN THE ELEVATION VIEW. ADJACENT SPLICES TO BE OFFSET 2'-0". MECHANICAL BUTT SPLICES SHALL BE IN ACCORDANCE WITH THE STANDARD SPECIFICATIONS. MECHANICAL BUTT SPLICES SHALL BE SUBMITTED FOR APPROVAL. NO EXTRA PAYMENT WILL BE MADE FOR USING MECHANICAL BUTT SPLICES OR MODIFYING BAR LENGTHS. THE COST WILL BE INCIDENTAL TO REINFORCING STEEL.

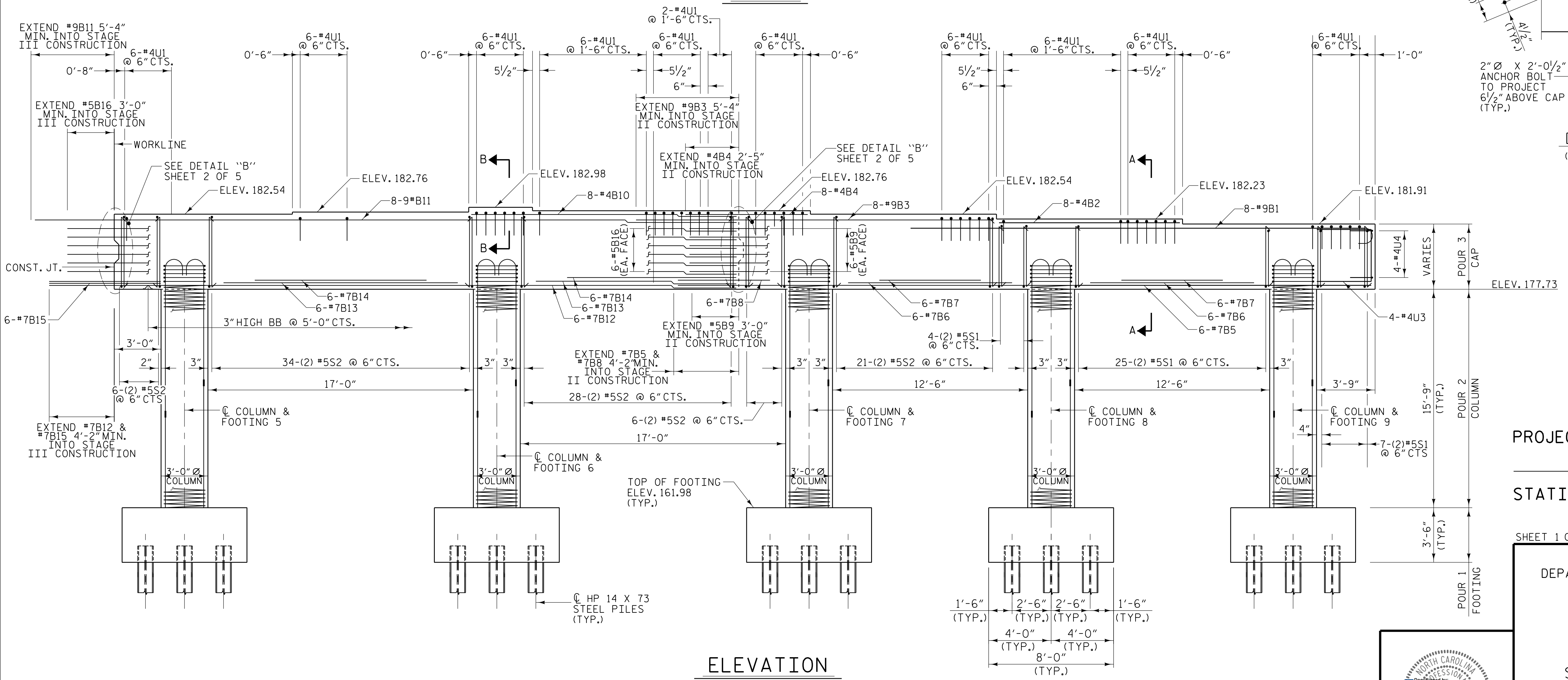
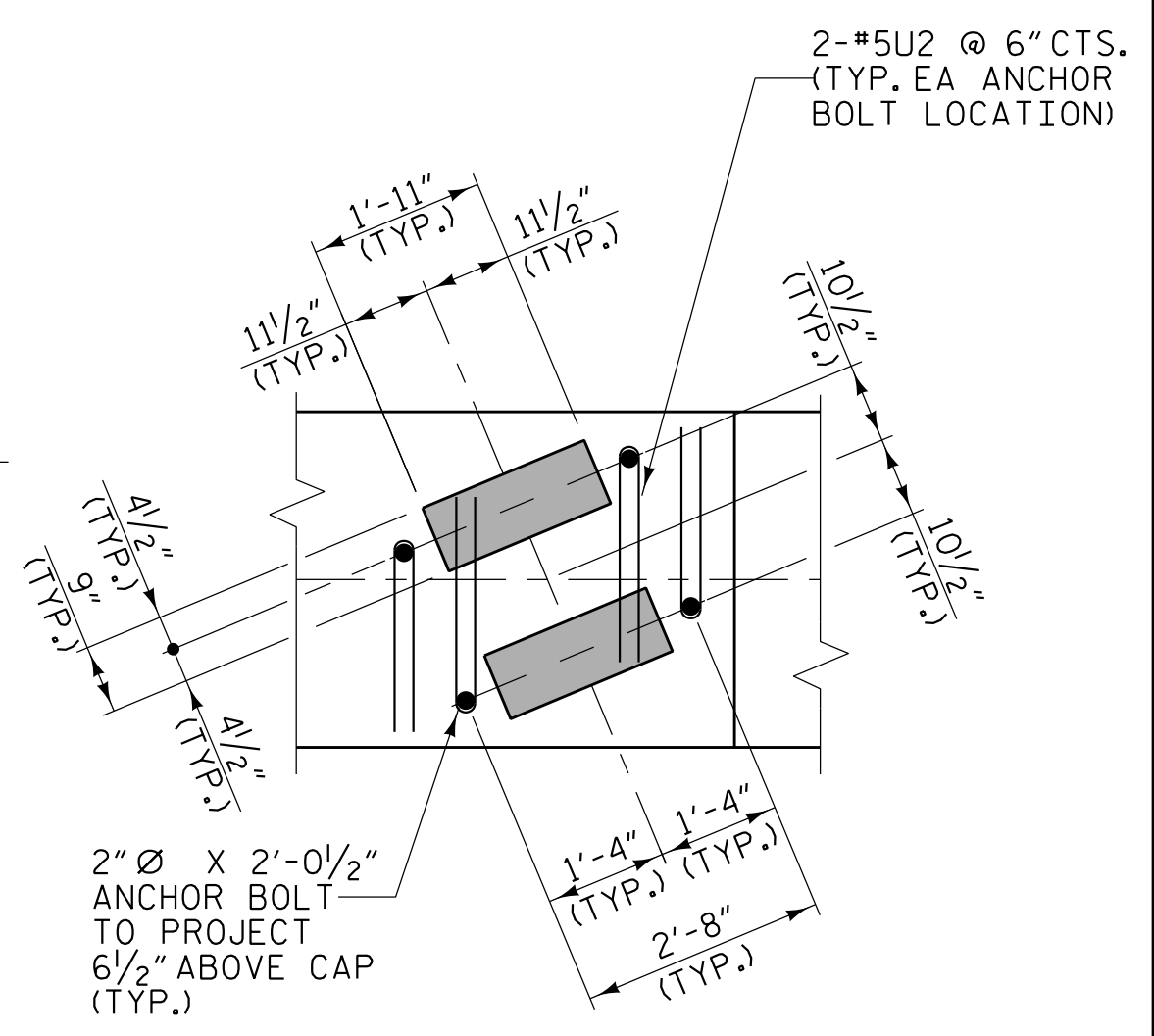
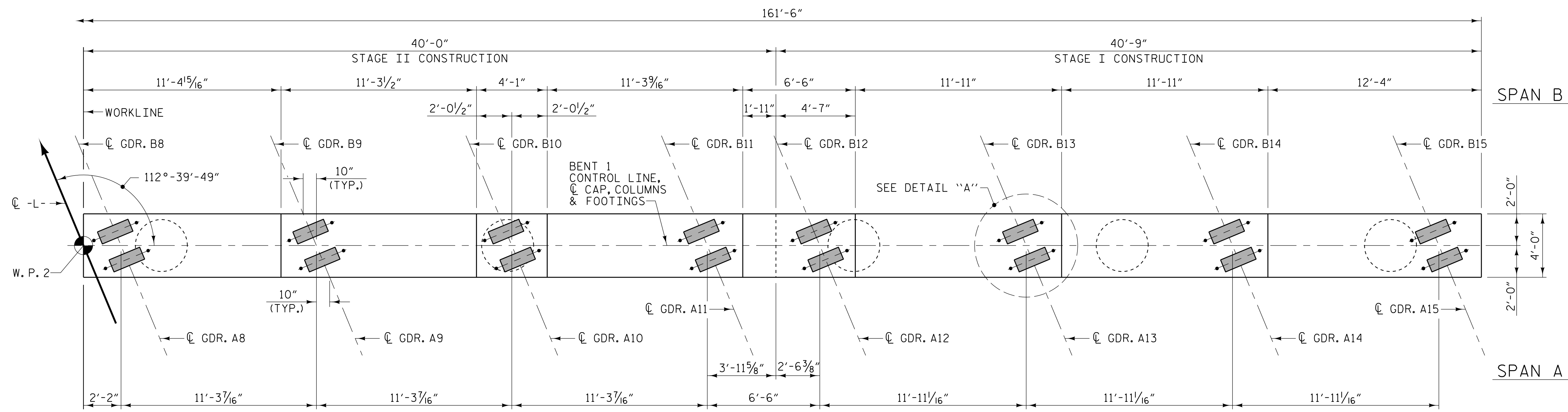

PLANS PREPARED BY:

NV5

NV5 ENGINEERS & CONSULTANTS, INC.
3300 REGENCY PARKWAY, SUITE 100
CARY, NC 27518
P: 919.851.1912 www.NV5.com
NC License # F-1333

PROJECT NO. I-5987B

ROBESON COUNTY

STATION: 617+12.20 -L- POT

SHEET 1 OF 5

STATE OF NORTH CAROLINA
DEPARTMENT OF TRANSPORTATION
RALEIGH

SUBSTRUCTURE
BENT 1
STAGE I & STAGE II

REVISIONS						SHEET NO.
NO.	BY:	DATE:	NO.	BY:	DATE:	TOTAL SHEETS
1			3			53
2			4			

DRAWN BY : W.B. ALLEN DATE : 12/21

CHECKED BY : M.D. METZGER DATE : 12/21

DESIGN ENGINEER OF RECORD: L. K. AUSTIN DATE : 01/22

**DOCUMENT NOT CONSIDERED FINAL
UNLESS ALL SIGNATURES COMPLETED**

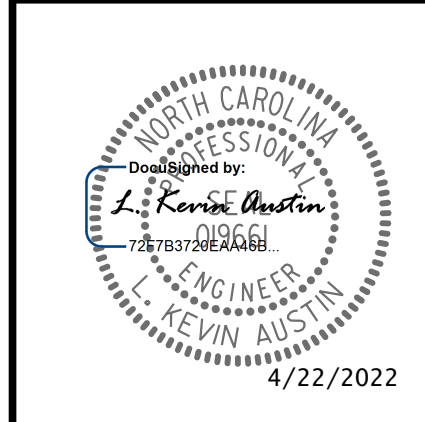

4/20/2022 11:43:33 AM G:\Projects\2019\201912\03\CLIENTS\Structures\I-5987B\I5 - NC 20190818\B.SMU.BI.770159.dgn