

NOTES
FOR NOTES SEE SHEET 1 OF 6.

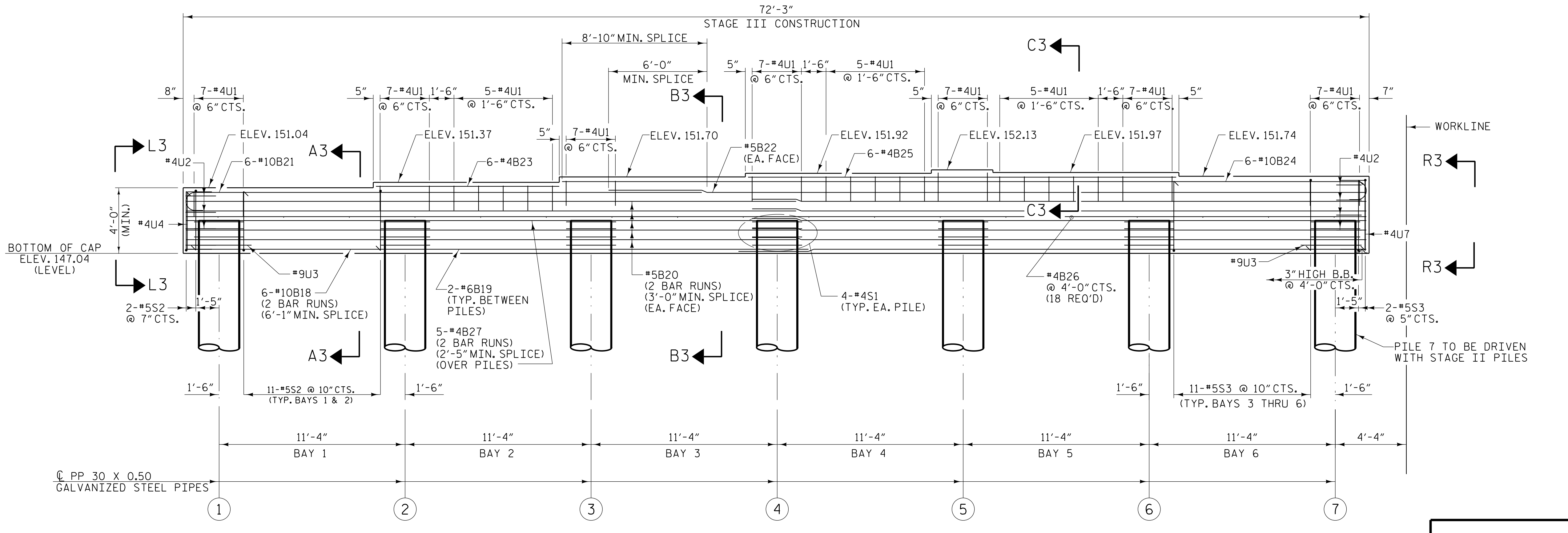
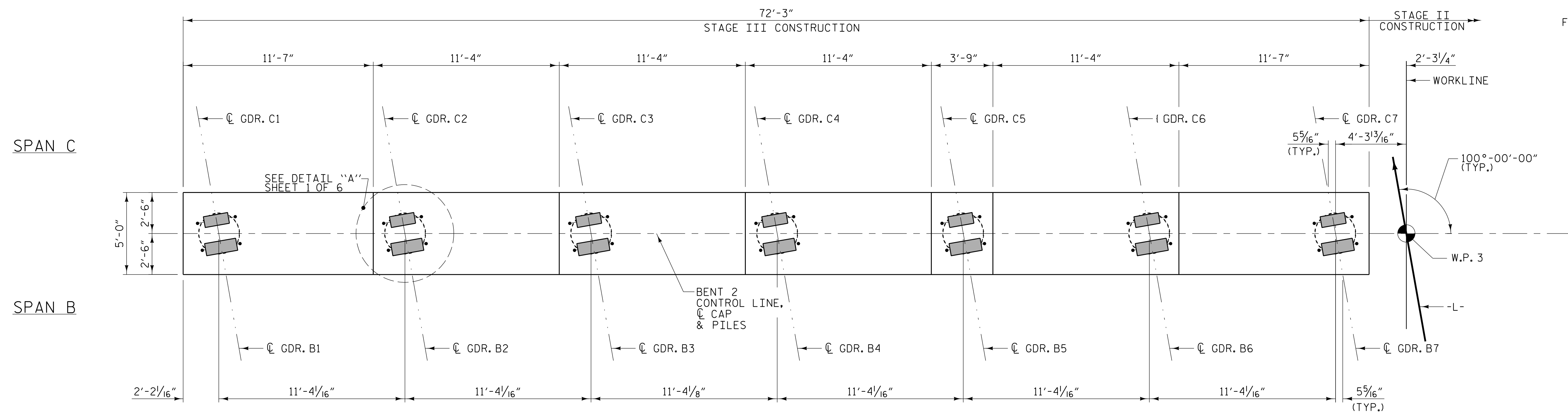

PLANS PREPARED BY:

NV5

NV5 ENGINEERS & CONSULTANTS, INC.
3300 REGENCY PARKWAY, SUITE 100
CARY, NC 27518
P: 919.851.1912 www.NV5.com
NC License # F-13333

PROJECT NO. I-5987B
ROBESON COUNTY
 STATION: 586+14.00 -L- POT

SHEET 5 OF 6

STATE OF NORTH CAROLINA
 DEPARTMENT OF TRANSPORTATION
 RALEIGH

SUBSTRUCTURE
 BENT 2
 STAGE III

REVISIONS						SHEET NO.	
NO.	BY:	DATE:	NO.	BY:	DATE:	S5-51	
1			3			TOTAL SHEETS	
2			4			64	

4/25/2022 3:46:57 PM G:\Project\1208\20957\03\CLIENT\Structures\I-5987B\Big Marsh_Swamp\I5987B_SMU_BLI_170536.dgn

DRAWN BY : J.A. PANDOLI DATE : 2/22
 CHECKED BY : G.F. WILSON DATE : 2/22
 DESIGN ENGINEER OF RECORD: L.K. AUSTIN DATE : 2/22

**DOCUMENT NOT CONSIDERED FINAL
 UNLESS ALL SIGNATURES COMPLETED**



4/25/2022