

NOTES
FOR NOTES SEE SHEET 1 OF 6.

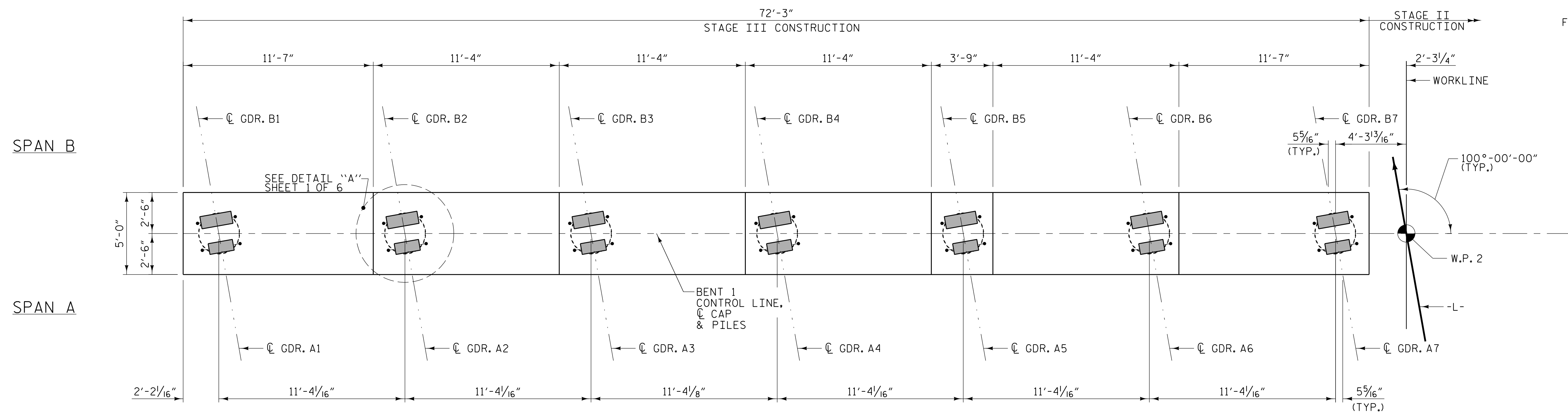

PLAN

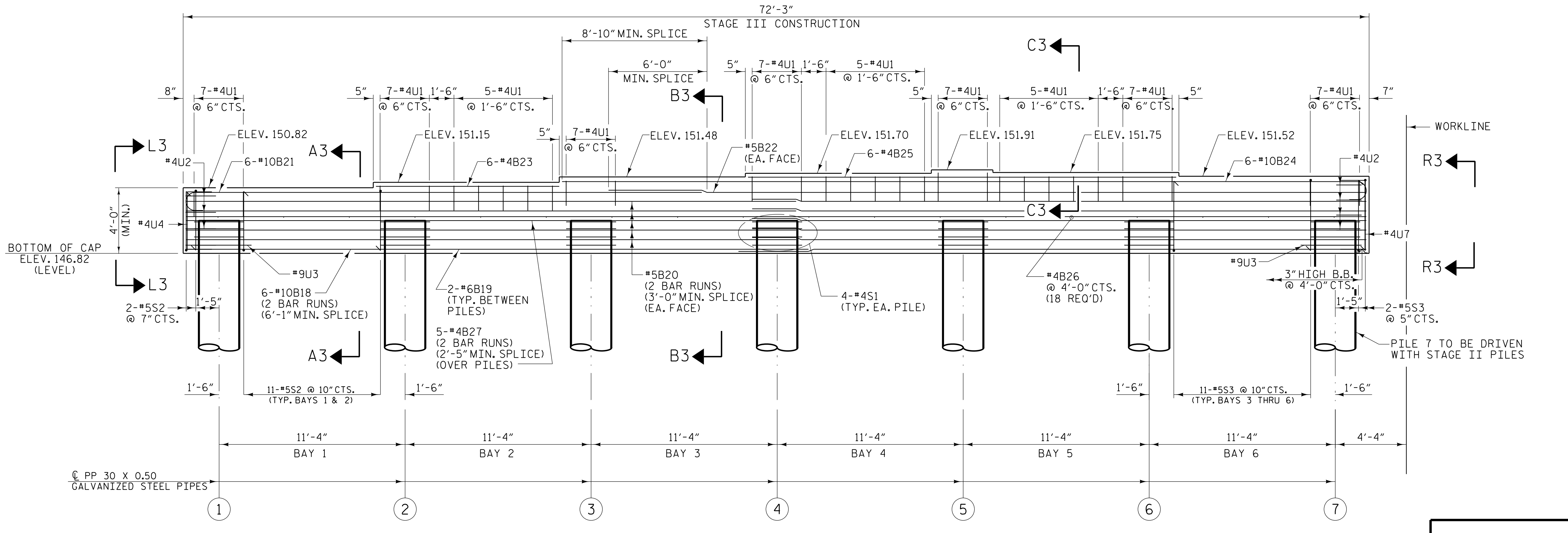

ELEVATION
⊕ INDICATES PILE NUMBER

PLANS PREPARED BY:

NV5

NV5 ENGINEERS & CONSULTANTS, INC.
3300 REGENCY PARKWAY, SUITE 100
CARY, NC 27518
P: 919.851.1912 www.NV5.com
NC License # F-13333

PROJECT NO. I-5987B
ROBESON COUNTY
 STATION: 586+14.00 -L- POT

SHEET 5 OF 6

STATE OF NORTH CAROLINA
 DEPARTMENT OF TRANSPORTATION
 RALEIGH

SUBSTRUCTURE
BENT 1
 STAGE III

REVISIONS						SHEET NO.
NO.	BY:	DATE:	NO.	BY:	DATE:	S5-45
1			3			TOTAL SHEETS
2			4			64

4/25/2022 3:57:59 PM G:\Project\1208\20957\03\CLIENT\Structures\I-5987B (Big Marsh Swamp)\5987B_SMU_B5_770536.dgn

DRAWN BY : J.A. PANDOLI DATE : 2/22
 CHECKED BY : G.F. WILSON DATE : 2/22
 DESIGN ENGINEER OF RECORD: L.K. AUSTIN DATE : 2/22

**DOCUMENT NOT CONSIDERED FINAL
 UNLESS ALL SIGNATURES COMPLETED**

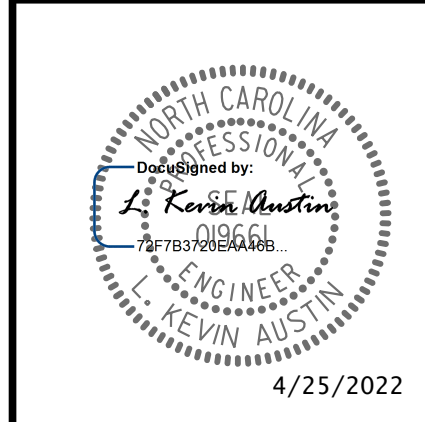

4/25/2022