

### EDI MODEL 2018ECL-NC CONFLICT MONITOR PROGRAMMING DETAIL

(remove jumpers and set switches as shown)

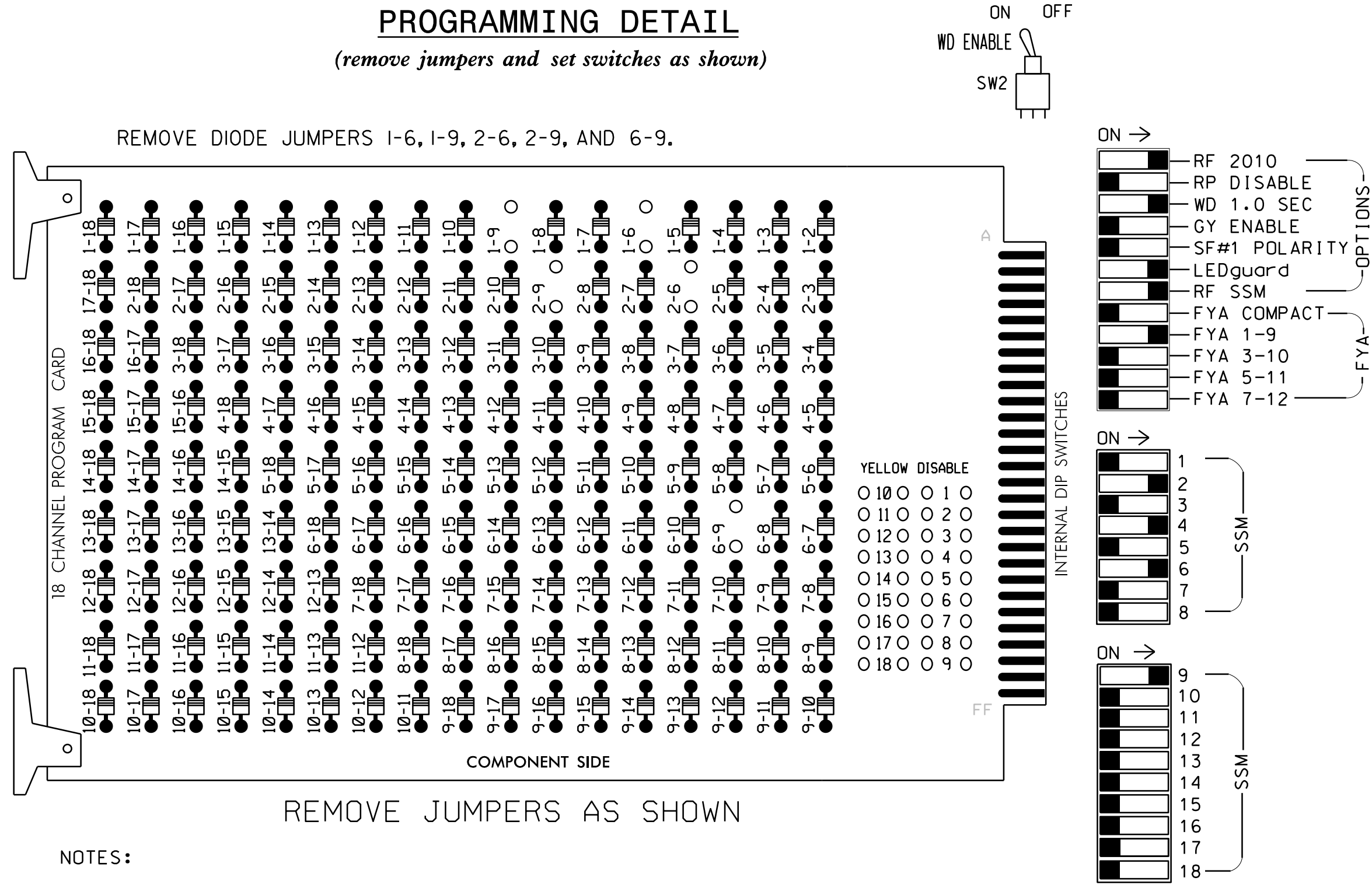

**NOTES:**

1. Card is provided with all diode jumpers in place. Removal of any jumper allows its channels to run concurrently.
2. Ensure jumpers SEL2-SEL5 and SEL9 are present on the monitor board.
3. Ensure that Red Enable is active at all times during normal operation.
4. Connect serial cable from conflict monitor to comm. port 1 of 2070 controller. Ensure conflict monitor communicated with 2070.

### NOTES

1. To prevent "flash-conflict" problems, insert red flash program blocks for all unused vehicle load switches in the output file. The installer shall verify that signal heads flash in accordance with the Signal Plans.
2. Program controller to start up in phase 2 Green and 6 Green.
3. If this signal will be managed by an ATMS software, enable controller and detector logging for all detectors used at this location.
4. The cabinet and controller are part of the D06-21 St. Pauls System.

### EQUIPMENT INFORMATION

CONTROLLER.....2070LX  
 CABINET.....332 W/AUX  
 SOFTWARE.....ECONOLITE ASC/3-2070  
 CABINET MOUNT.....BASE  
 OUTPUT FILE POSITIONS...18 WITH AUX. OUTPUT FILE  
 LOAD SWITCHES USED.....S1,S2,S5,S8,AUX S1  
 PHASES USED.....1,2,4,6  
 OVERLAP "A".....\*  
 OVERLAP "B".....NOT USED  
 OVERLAP "C".....NOT USED  
 OVERLAP "D".....NOT USED

\* See overlap programming detail on sheet 2

### SIGNAL HEAD HOOK-UP CHART

LOAD SWITCH NO.	S1	S2	S3	S4	S5	S6	S7	S8	S9	S10	S11	S12	AUX S1	AUX S2	AUX S3	AUX S4	AUX S5	AUX S6	
CMU CHANNEL NO.	1	2	13	3	4	14	5	6	15	7	8	16	9	10	17	11	12	18	
PHASE	1	2	2 PED	3	4	4 PED	5	6	6 PED	7	8	8 PED	OLA	OLB	SPARE	OLC	OLD	SPARE	
SIGNAL HEAD NO.	11*	21,22	NU	NU	41,42, 43,44	NU	NU	61,62	NU	NU	NU	NU	11*	NU	NU	NU	NU	NU	
RED	128				101			134											
YELLOW	*	129			102			135											
GREEN		130			103			136											
RED ARROW																		A121	
YELLOW ARROW																			A122
FLASHING YELLOW ARROW																			A123
GREEN ARROW	127																		

NU = Not Used

\* Denotes install load resistor. See load resistor installation detail this sheet.

★ See pictorial of head wiring in detail this sheet.

### INPUT FILE POSITION LAYOUT

(front view)

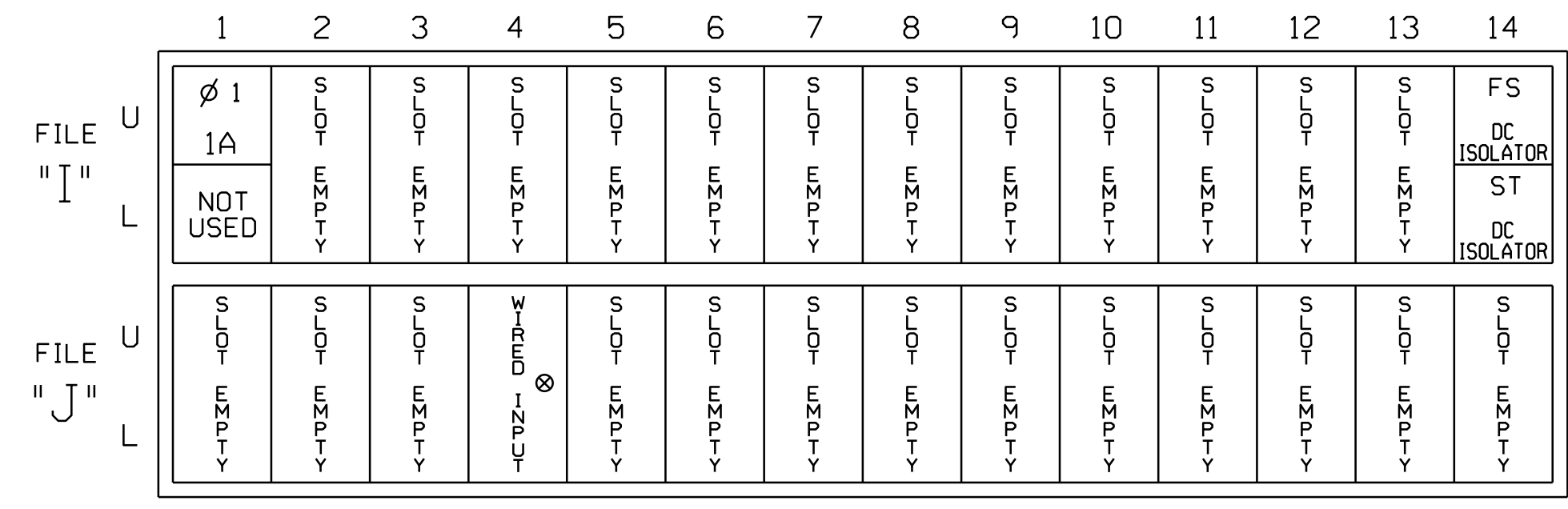

EX.: 1A, 2A, ETC. = LOOP NO.'S

FS = FLASH SENSE  
 ST = STOP TIME

⊗ Wired Input - Do not populate slot with detector card

### INPUT FILE CONNECTION & PROGRAMMING CHART

LOOP NO.	LOOP TERMINAL	INPUT FILE POS.	PIN NO.	DETECTOR NO.	NEMA PHASE	CALL	EXTEND TIME	DELAY TIME	ADDED INITIAL	DETECTOR TYPE
1A <sup>1</sup>	TB2-1,2	I1U	56	1	1	YES		15		N
	-	J4U	48	26	6	YES				N

<sup>1</sup>Add jumper from I1-W to J4-W, on rear of input file.

### INPUT FILE POSITION LEGEND: J2L

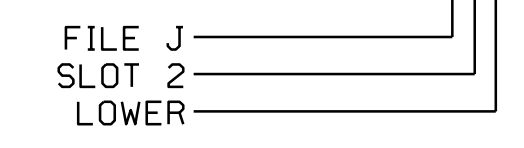

### FYA SIGNAL WIRING DETAIL

(wire signal head as shown)

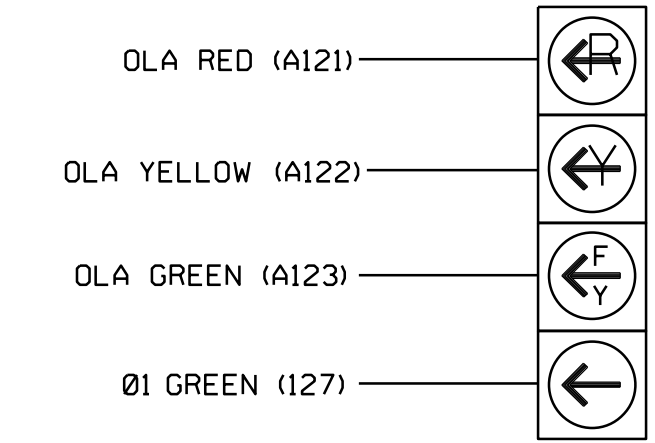

11

### SPECIAL DETECTOR NOTE

Install a multi-zone microwave detection system for vehicle detection. Perform installation according to the manufacturer's directions and NCDOT engineer approved mounting locations to accomplish the detection schemes shown on the Signal Design Plans.

For Detection Zone 1A the equipment and slots reserved for wired inputs are typical for a NCDOT installation.

### LOAD RESISTOR INSTALLATION DETAIL

(install resistor as shown)

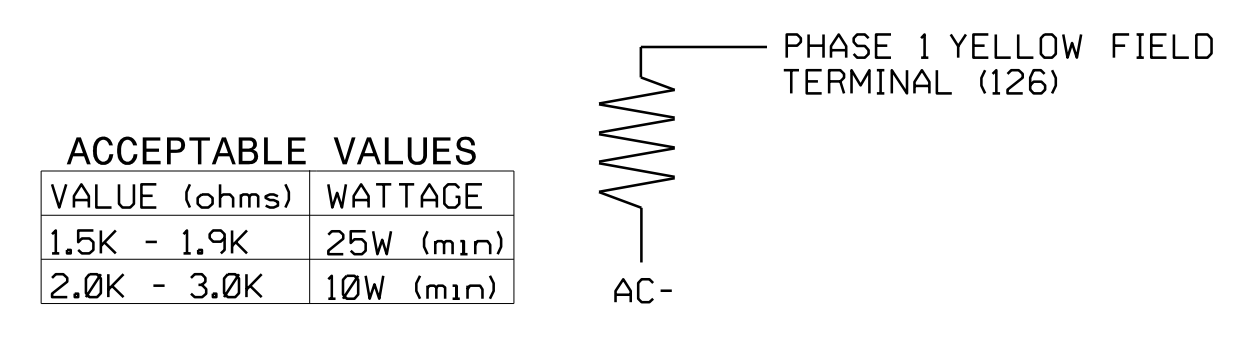

ACCEPTABLE VALUES	
VALUE (ohms)	WATTAGE
1.5K - 1.9K	25W (min)
2.0K - 3.0K	10W (min)

Electrical Detail Sheet 1 of 2  
 Temporary Design 6 - (TMP Phase 4.2)

DOCUMENT NOT CONSIDERED FINAL UNLESS ALL SIGNATURES COMPLETED

 RAMEY KEMP ASSOCIATES 8210 University Executive Park Drive Suite 220 Charlotte, North Carolina 28212 Phone: 704-548-4260   www.rameykemp.com   NC License No. C-9910	NC 20 (W. Broad St.) at I-95 SB Ramps		SEAL  WILLIAM J. HAMILTON ENGINEER
	Division 6 Robeson County St. Pauls PLAN DATE: February 2022 REVIEWED BY: WJ Hamilton PREPARED BY: TS Popelka RKA PROJ. NO.: 21031 (040)	REVISIONS INIT. DATE _____ _____ _____	