

PLANS PREPARED FOR THE NCDOT BY:

**M** MOTT MACDONALD I & E, LLC  
 1101 HAYNES STREET, SUITE 101  
 RALEIGH, NC 27604  
**M** MOTT MACDONALD NC LICENSE NO. F-0669

NOTE: THE WORK SHOWN IN I-5987B PHASE IV TO BE COORDINATED WITH WORK SHOWN IN I-5987A PHASE III AND PHASE IV

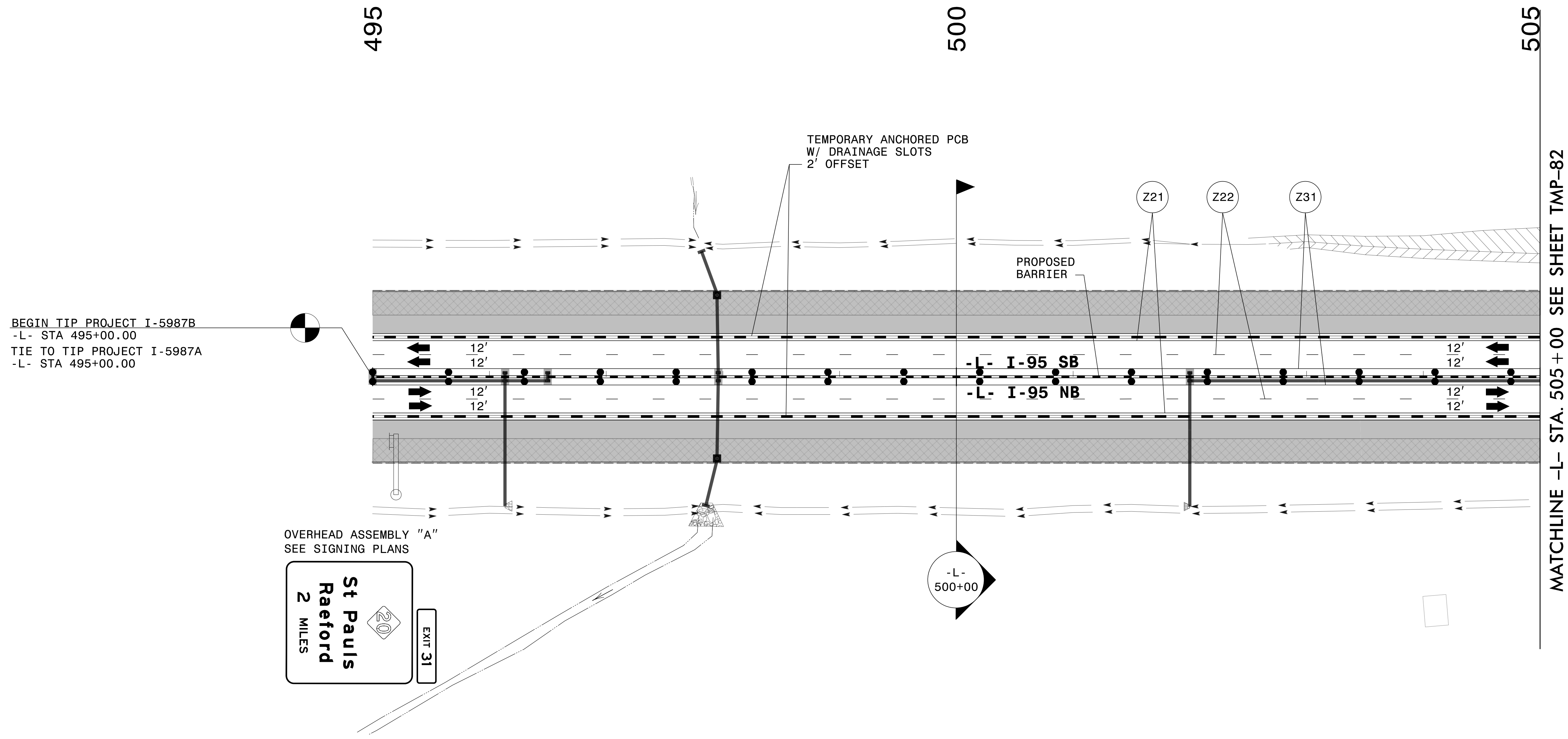

BEGIN TIP PROJECT I-5987B  
 -L- STA 495+00.00  
 TIE TO TIP PROJECT I-5987A  
 -L- STA 495+00.00

OVERHEAD ASSEMBLY "A"  
 SEE SIGNING PLANS

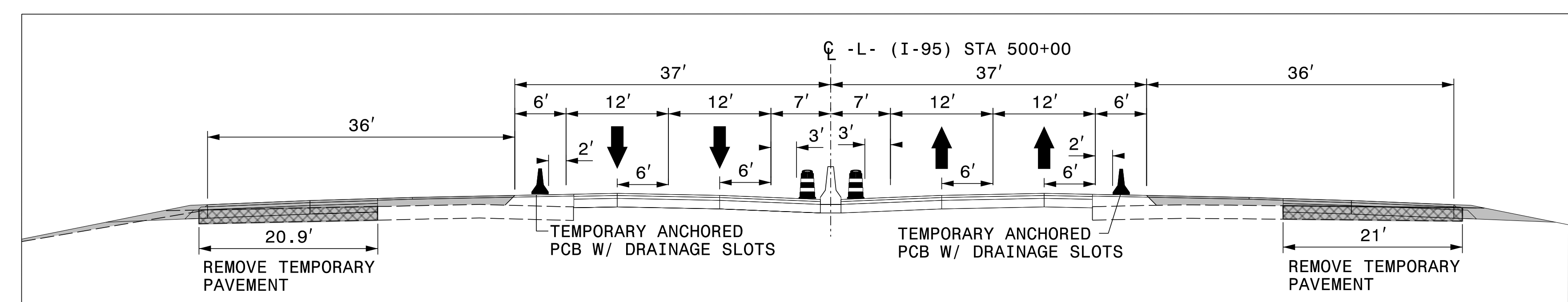

APPROVED: *Lois D. Stouchko*  
 DATE: \_\_\_\_\_  
 SEAL 034437  
 LOIS D. STOUCHKO  
 ENGINEER

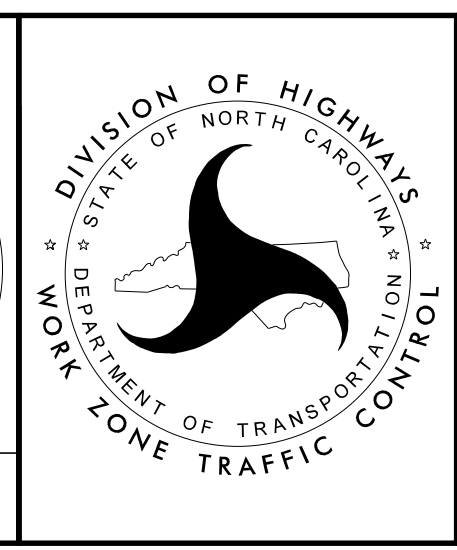

SECTION 1  
 TEMPORARY TRAFFIC CONTROL  
 PHASE IV

DOCUMENT NOT CONSIDERED FINAL  
 UNLESS ALL SIGNATURES COMPLETED

3/29/2022  
 G:\50100191\NV5\_L-5987B\TrafficControl\TcP\200\_391\_L-5987B\_TMP-81\_Phase IV\_Step L4.dgn  
 User:ST086227