

5/14/99

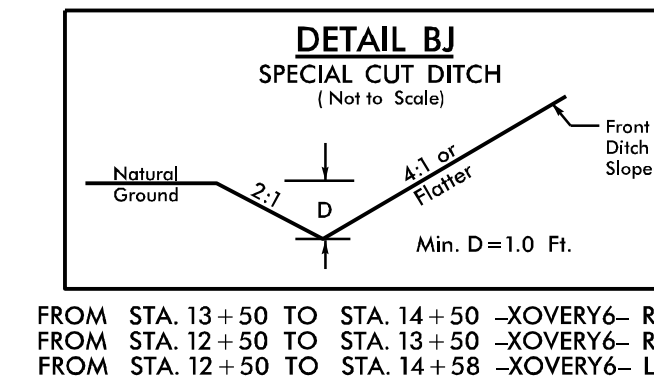
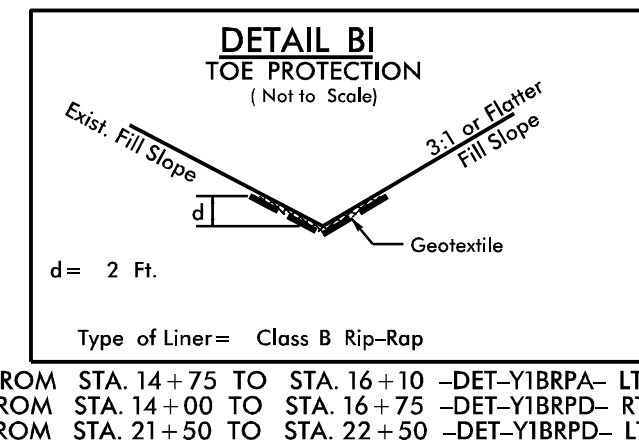
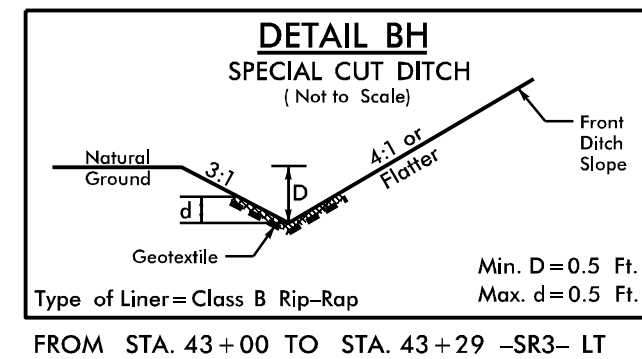
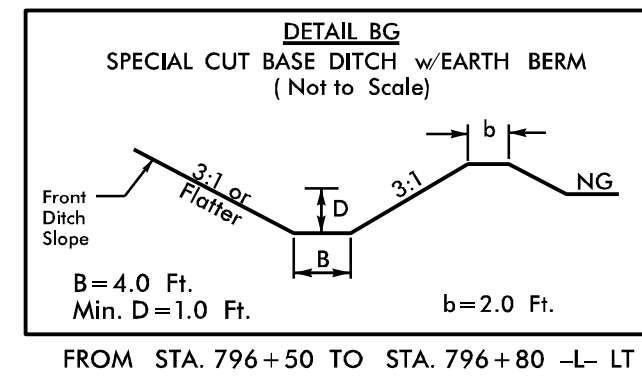
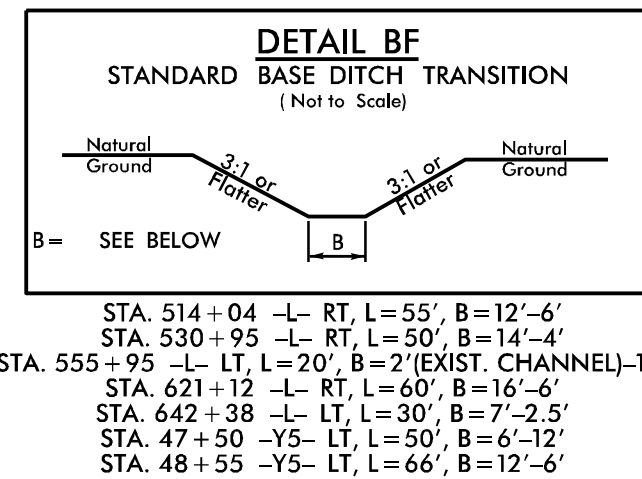
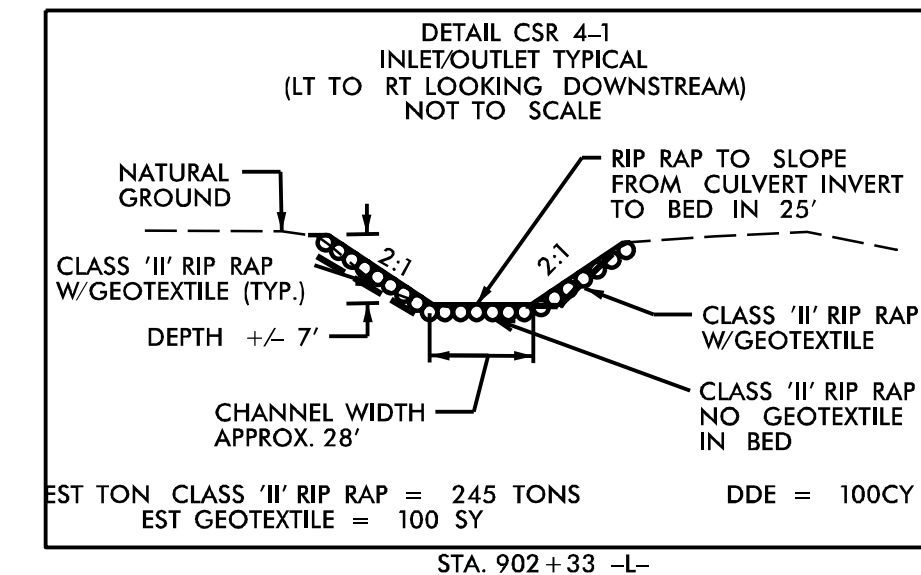
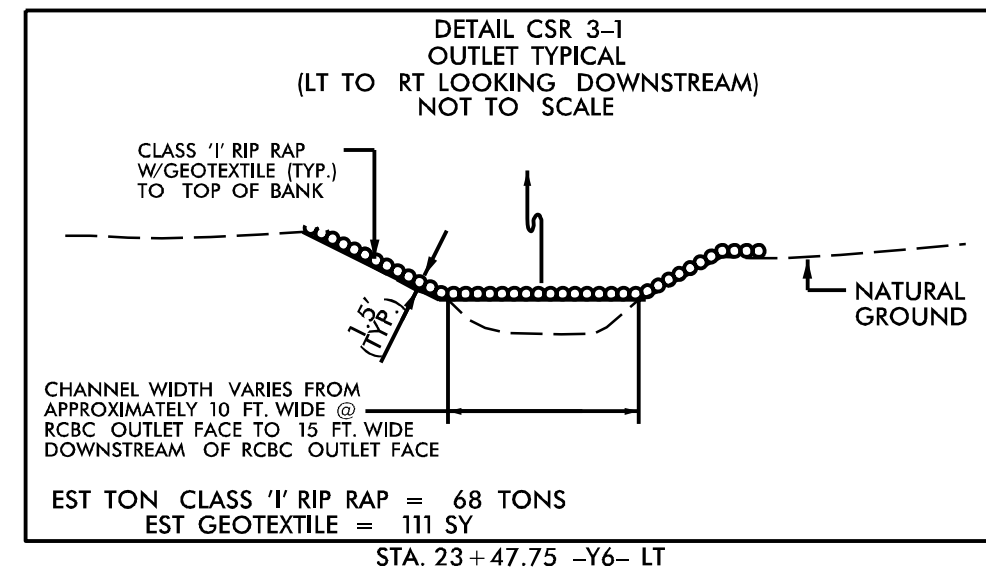
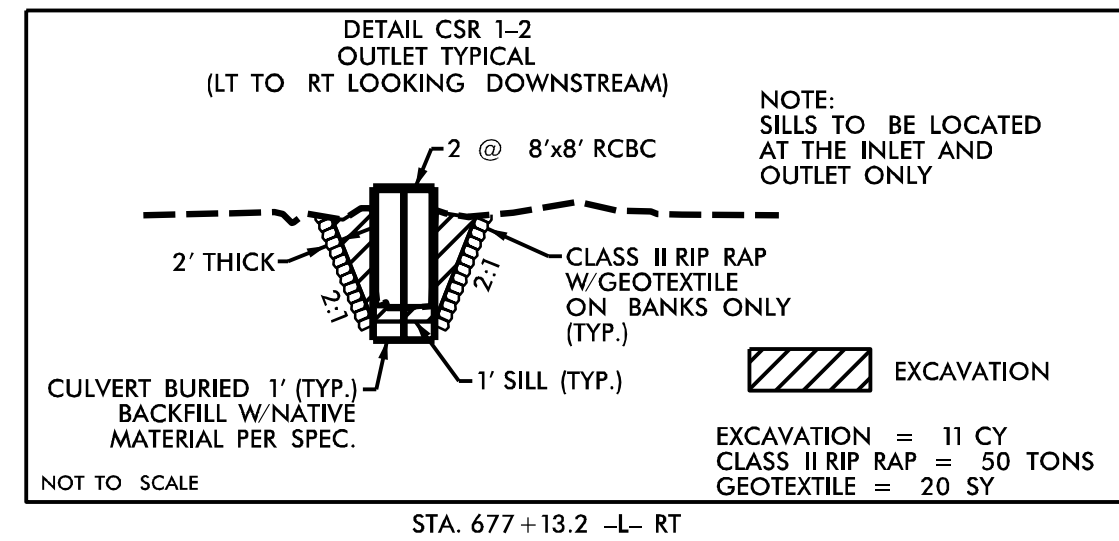
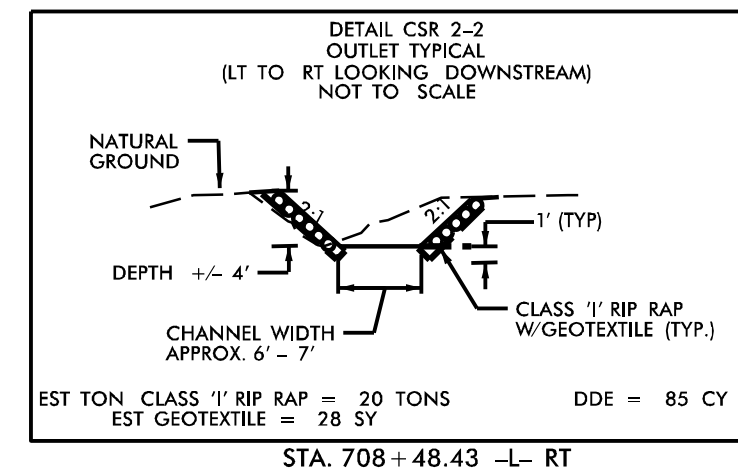
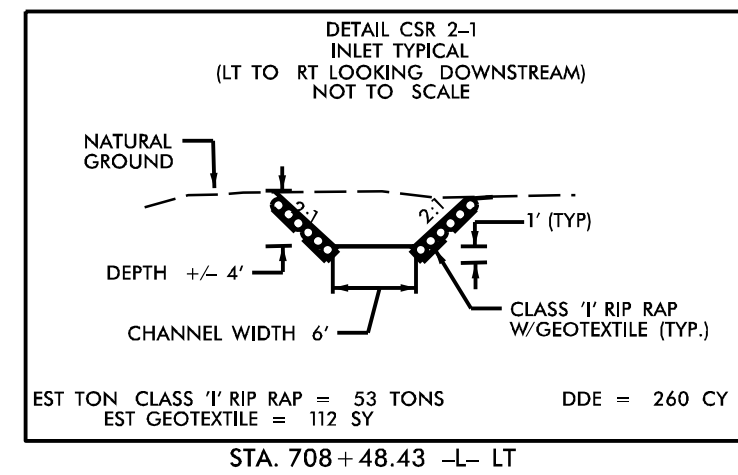
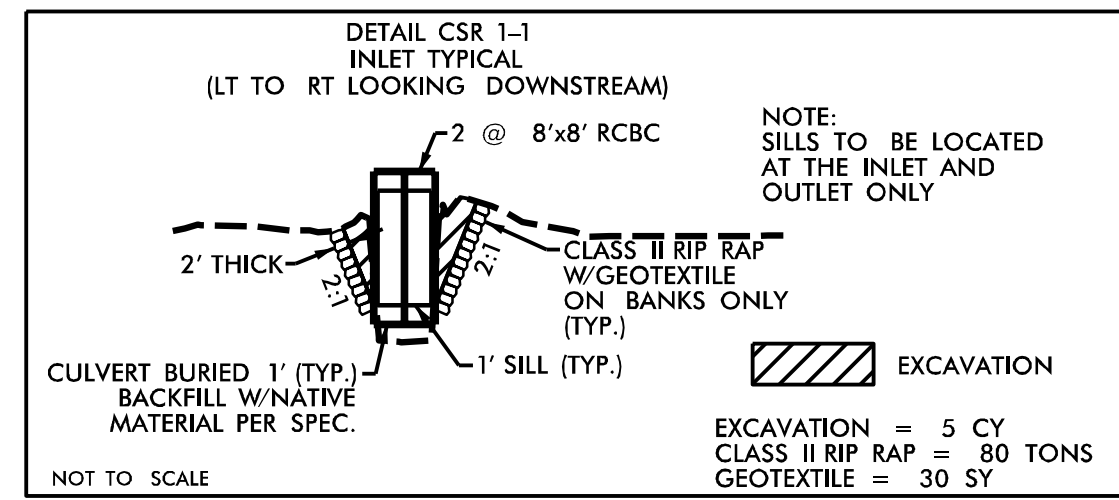

PROJECT REFERENCE NO. 1-5897B	SHEET NO. 2D-3
RW SHEET NO.	
ROADWAY DESIGN ENGINEER 	HYDRAULICS ENGINEER
MOTT MACDONALD I & E, LLC LICENSE NO. F-0669	
DOCUMENT NOT CONSIDERED FINAL UNLESS ALL SIGNATURES COMPLETED	
Prepared in the Office of: 	7621 Purfoy Road, Suite 115 Fuquay-Varina, NC 27526 (919) 552-2253 www.mottmac.com MOTT MACDONALD NC License No. F-0669

4/28/2022 R:\Drawings\15987B_hyd_psh_20_Ditch_Details.dgn