

**GENERAL NOTES:**

CONSTRUCT CONCRETE BARRIER WITH CLASS 'AA' CONCRETE. (SEE SPECIFICATIONS SECTION 854).

CONSTRUCT EXPANSION AND CONTRACTION JOINTS AS SHOWN IN STANDARD DRAWING 854.01.

SEAL EXPANSION JOINTS WITH JOINT FILLER. (SEE SECTION 1028 OF THE SPECIFICATIONS).

SUBMIT ALTERNATIVE METHODS FOR STEEL FABRICATION PLACEMENT FOR REVIEW AND APPROVAL.

SEE STANDARD DRAWING 854.05 FOR STEEL LAYOUT OF TRANSITION BARRIER.

\*THE 2" DIMENSION FROM FINISH GRADE TO THE BASE IS A MINIMUM DIMENSION.

INSET FIRST 1" DIA. GALVANIZED BAR 12'-6" AND SPACE THE REMAINING 1' BARS AT 25'-0".

USE AN APPROVED BONDING SYSTEM IN ACCORDANCE WITH SECTION 1081 OF THE STANDARD SPECIFICATIONS.

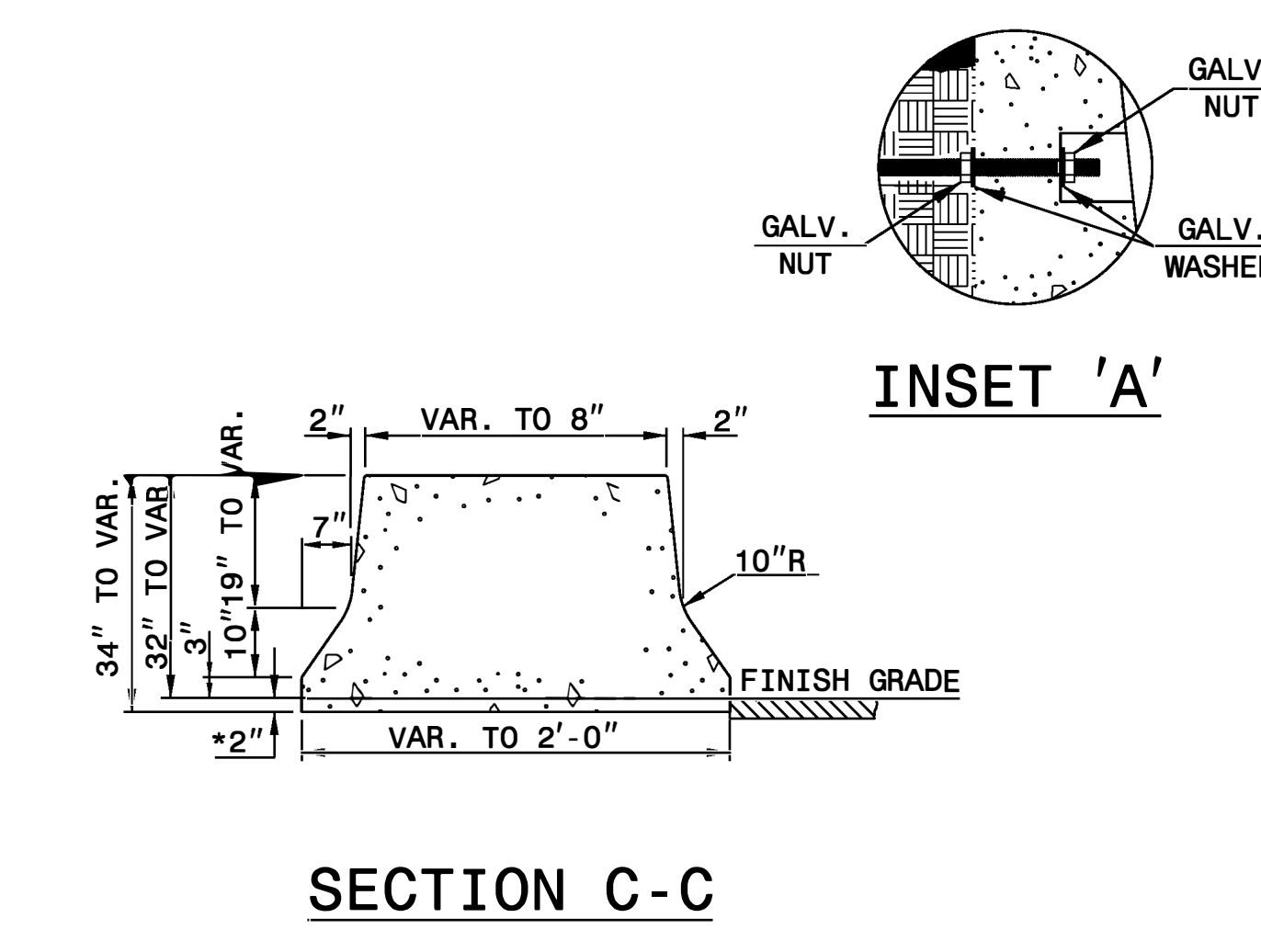
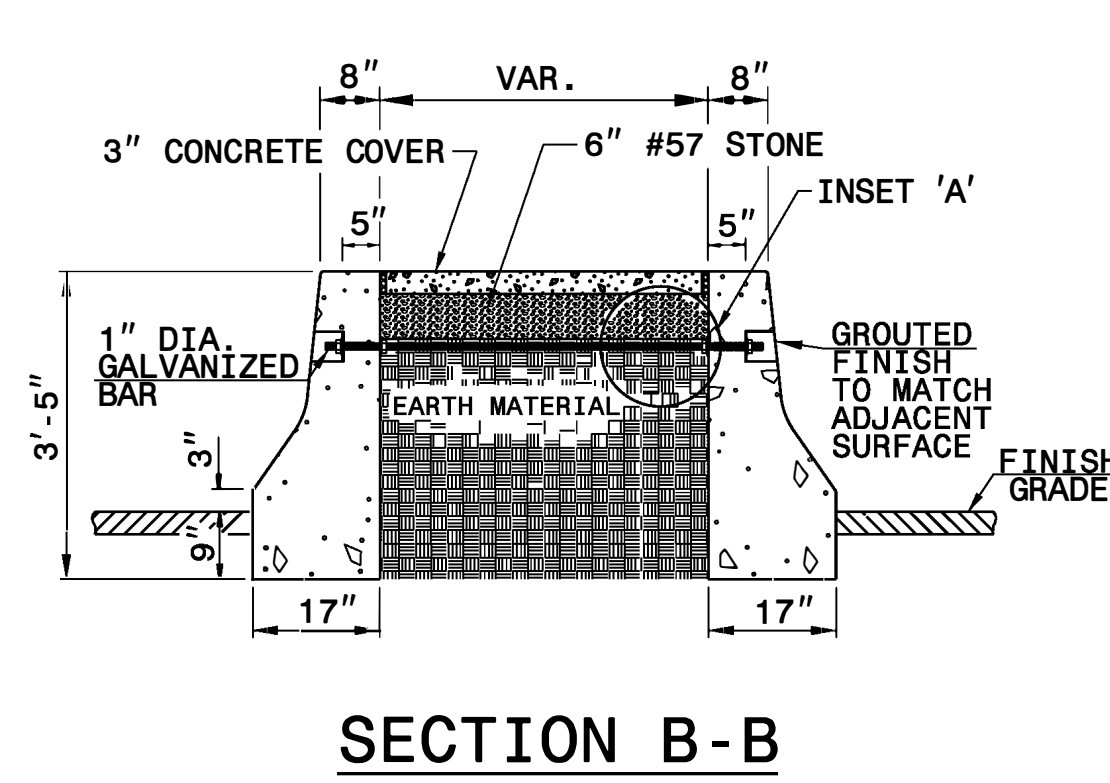
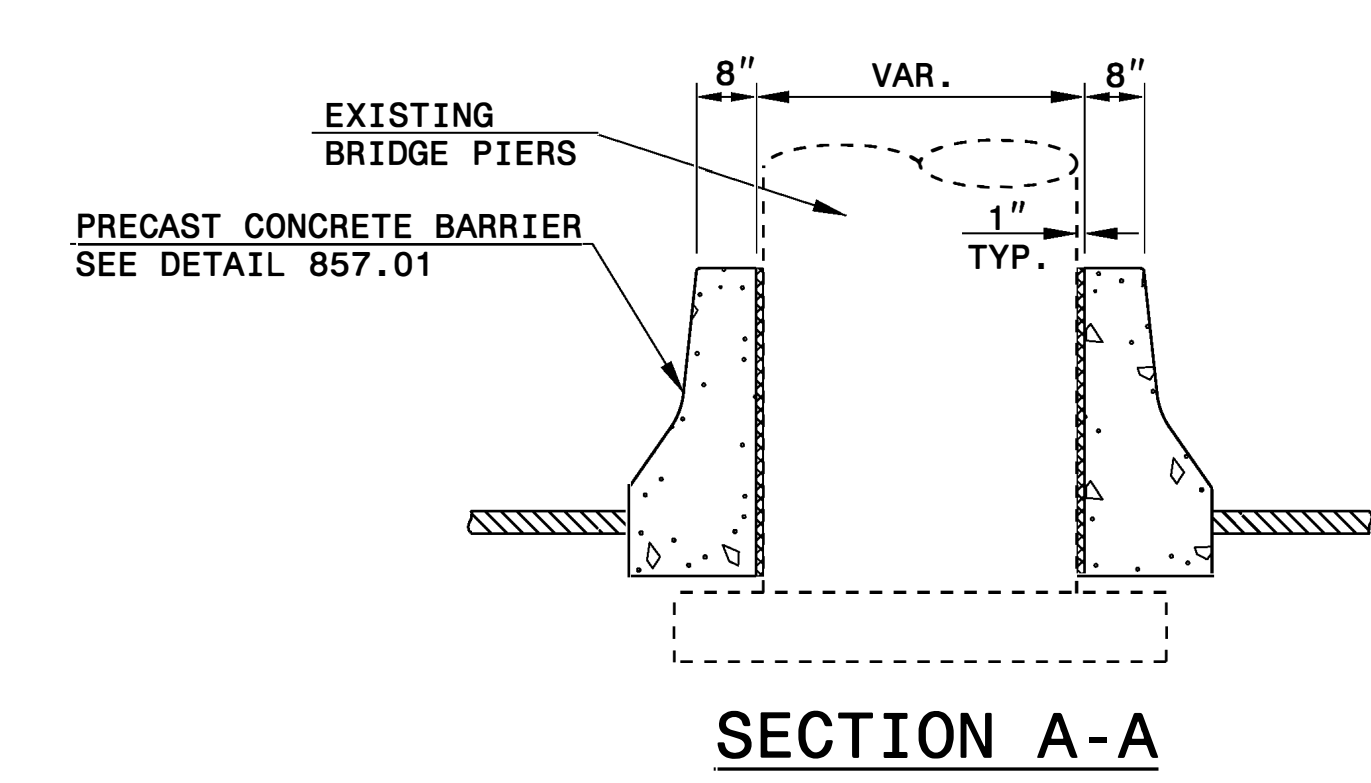
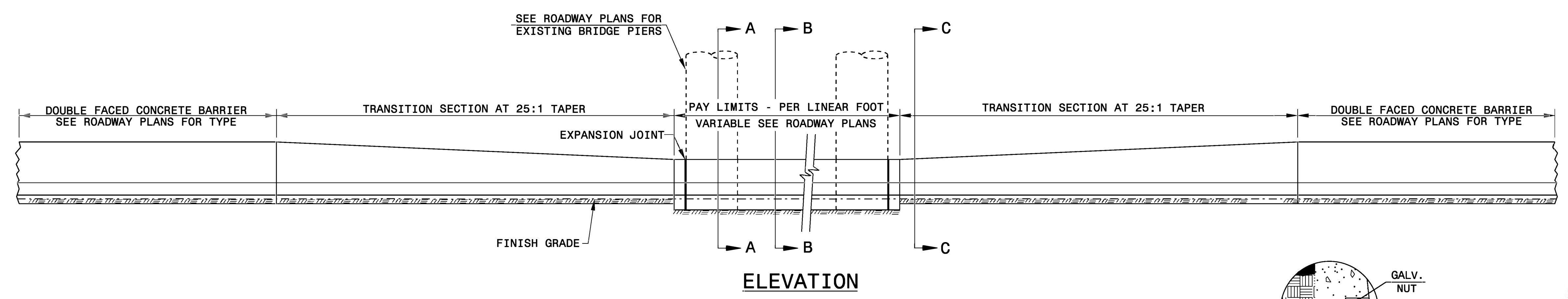

07-JUN-2017 08:44 S:\Contracts\Special Details\Vericard\usr\details\stand\Median Pier transition barrier.dgn Jhoverton AT USD-292595



DOCUMENT NOT CONSIDERED FINAL UNLESS ALL SIGNATURES COMPLETED

**CONTRACT STANDARDS AND DEVELOPMENT UNIT**  
Office 919-707-6950 FAX 919-250-4119

**MEDIAN HAZARD PIER PROTECTION**

ORIGINAL BY: E.E. WARD DATE: 7-28-03  
 MODIFIED BY: E.E. WARD DATE: 8-26-04  
 CHECKED BY: DATE:  
 FILE SPEC.: \usr\details\stand\transition barrier.dgn