

**This electronic collection of documents is provided
for the convenience of the user
and is Not a Certified Document –**

**The documents contained herein were originally issued
and sealed by the individuals whose names and license
numbers appear on each page, on the dates appearing
with their signature on that page.**

**This file or an individual page
shall not be considered a certified document.**

STATE OF NORTH CAROLINA
DIVISION OF HIGHWAYS

TRANSPORTATION MANAGEMENT PLAN

PAMLICO COUNTY

(BRIDGE NO. 680038)

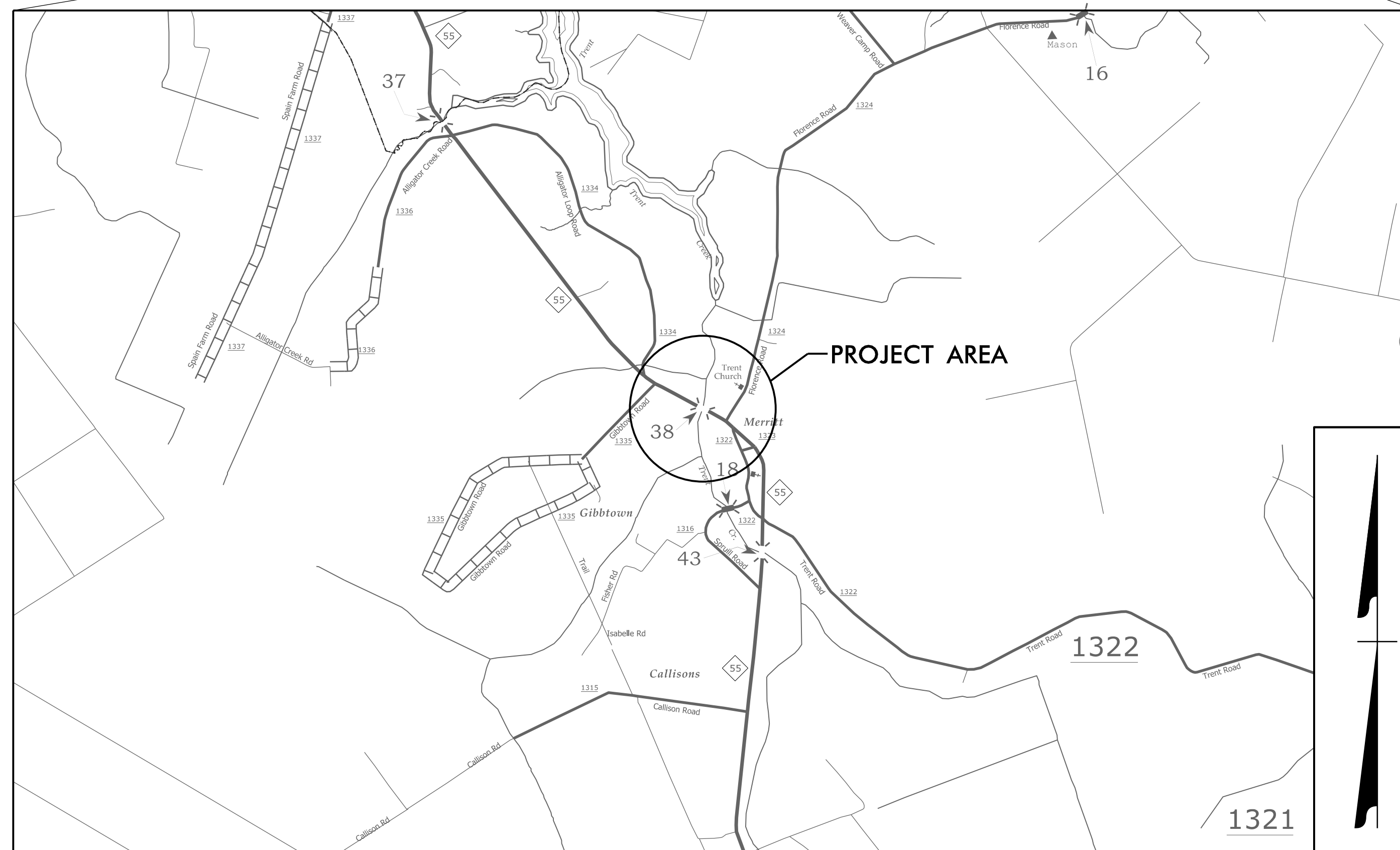
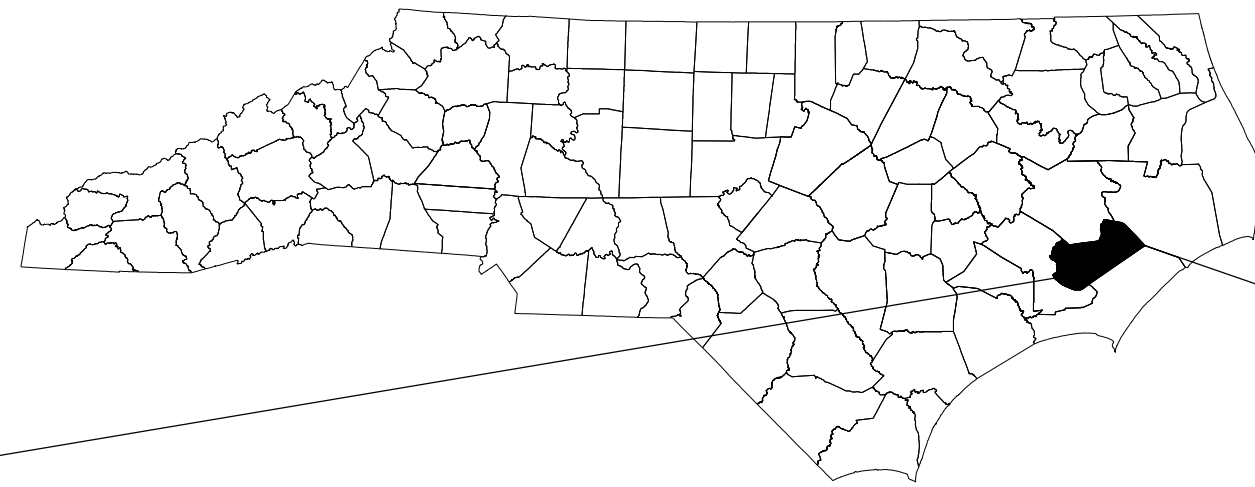

VICINITY MAP

INDEX OF SHEETS	
<u>SHEET NO.</u>	<u>TITLE</u>
TMP-1	TITLE SHEET, VICINITY MAP, AND INDEX OF SHEETS
TMP-1A	LIST OF APPLICABLE ROADWAY STANDARD DRAWINGS, LEGEND, AND TEMPORARY PAVEMENT MARKING SCHEDULE
TMP-1B THRU 1C	GENERAL NOTES
TMP-2	TEMPORARY SHORING DATA
TMP-3	MANAGEMENT STRATEGIES AND PHASING
TMP-4 THRU 7	DETAIL SHEETS

SHEET NO.
TMP-1

B-4593

TIP PROJECT:

**DOCUMENT NOT CONSIDERED FINAL
UNLESS ALL SIGNATURES COMPLETED**

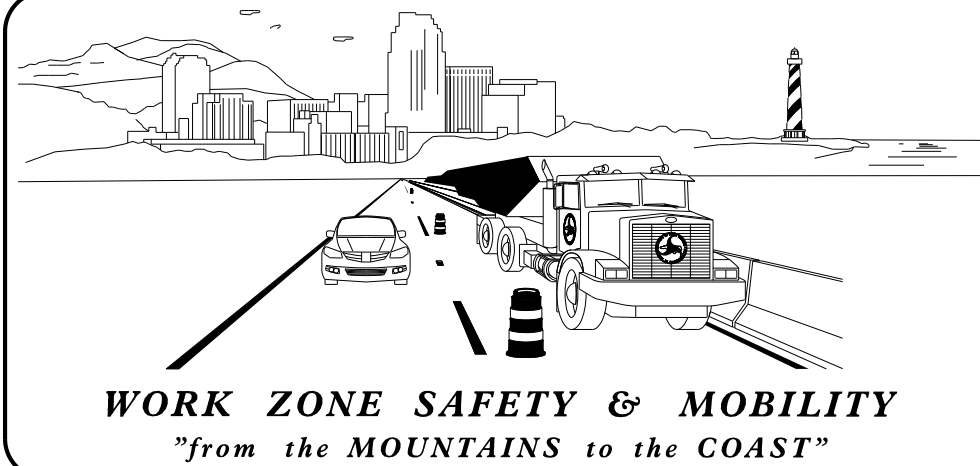

PLANS PREPARED BY:

BRANDON JOHNSON, PE

SPENCER MERRITT, PE

NCDOT CONTACTS:

STEVE KITE, PE
PROJECT ENGINEER

SPENCER JENNINGS
PROJECT DESIGN ENGINEER

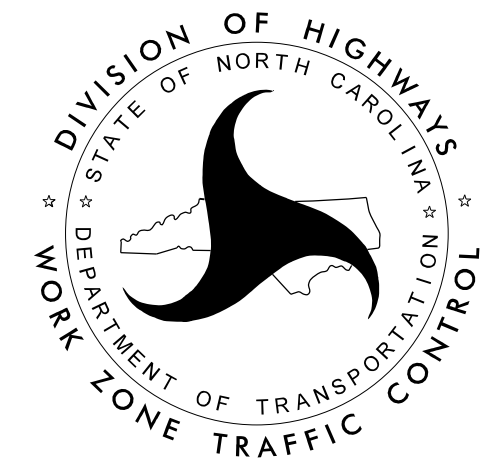

Prepared in the Office of:

SUMMIT
DESIGN AND ENGINEERING SERVICES

NC FIRM LICENSE No: P-0339
320 Executive Court
Hillsborough, NC 27278
(919) 732-3883
(919) 732-6676 (FAX)

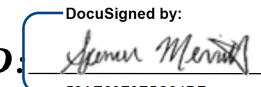
APPROVED: 
DATE: 5/5/2022

SEAL

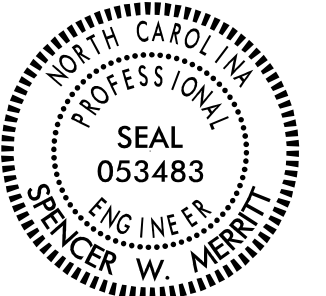

25-APR-2022 15:43
B4593.TC_TMP_Ldgn
conner.mcgraw



ROADWAY STANDARD DRAWINGS

THE FOLLOWING ROADWAY STANDARDS AS SHOWN IN "ROADWAY STANDARD DRAWINGS" - N.C. DEPARTMENT OF TRANSPORTATION - RALEIGH, N.C., DATED JANUARY 2018 ARE APPLICABLE TO THIS PROJECT AND BY REFERENCE HEREBY ARE CONSIDERED A PART OF THESE PLANS:

STD. NO.	TITLE
1101.01	WORK ZONE ADVANCE WARNING SIGNS
1101.02	TEMPORARY LANE CLOSURES
1101.03	TEMPORARY ROAD CLOSURES
1101.04	TEMPORARY SHOULDER CLOSURES
1101.05	WORK ZONE VEHICLE ACCESSES
1101.11	TRAFFIC CONTROL DESIGN TABLES
1110.01	STATIONARY WORK ZONE SIGNS
1110.02	PORTABLE WORK ZONE SIGNS
1115.01	FLASHING ARROW BOARDS
1130.01	DRUM
1135.01	CONES
1145.01	BARRICADES
1150.01	FLAGGING DEVICES
1160.01	TEMPORARY CRASH CUSHION
1165.01	WORK VEHICLE LIGHTING SYSTEMS AND TMA DELINEATION
1180.01	SKINNY-DRUM
1205.01	PAVEMENT MARKINGS - LINE TYPES AND OFFSETS
1205.02	PAVEMENT MARKINGS - TWO-LANE AND MULTI-LANE ROADWAYS
1205.04	PAVEMENT MARKINGS - INTERSECTIONS
1205.05	PAVEMENT MARKINGS - TURN LANES
1205.08	PAVEMENT MARKINGS - SYMBOLS AND WORD MESSAGES
1205.09	PAVEMENT MARKINGS - PAINTED ISLANDS
1205.12	PAVEMENT MARKINGS - BRIDGES
1250.01	RAISED PAVEMENT MARKERS - INSTALLATION SPACING
1251.01	RAISED PAVEMENT MARKERS - PERMANENT AND TEMPORARY
1261.01	GUARDRAIL AND BARRIER DELINEATORS - INSTALLATION SPACING
1261.02	GUARDRAIL AND BARRIER DELINEATORS - TYPES AND MOUNTING
1262.01	GUARDRAIL END DELINEATION
1264.01	OBJECT MARKERS - TYPES
1264.02	OBJECT MARKERS - INSTALLATION

LEGEND

GENERAL

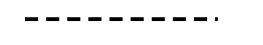
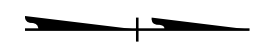
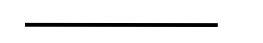
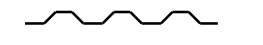
-  DIRECTION OF TRAFFIC FLOW
-  DIRECTION OF PEDESTRIAN TRAFFIC FLOW
-  EXIST. PVMT.
-  NORTH ARROW
-  PROPOSED PVMT.
-  TEMP. SHORING (LOCATION PURPOSES ONLY)

 WORK AREA

 REMOVAL

 USER DEFINED (IF NEEDED)

 USER DEFINED (IF NEEDED)



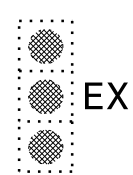
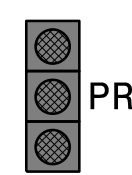
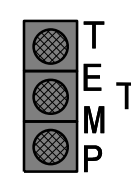







SIGNALS

-  EXISTING
-  PROPOSED
-  TEMPORARY

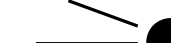

PAVEMENT MARKINGS

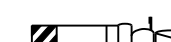
-  EXISTING LINES
-  TEMPORARY LINES



TRAFFIC CONTROL DEVICES

-  BARRICADE (TYPE III)
-  CONE
-  DRUM
-  SKINNY DRUM
-  TUBULAR MARKER
-  TEMPORARY CRASH CUSHION
-  FLASHING ARROW BOARD
-  FLAGGER
-  LAW ENFORCEMENT
-  TRUCK MOUNTED ATTENUATOR (TMA)
-  CHANGEABLE MESSAGE SIGN

TEMPORARY SIGNING

-  PORTABLE SIGN
-  STATIONARY SIGN
-  STATIONARY OR PORTABLE SIGN

PAVEMENT MARKERS

-  CRYSTAL/CRYSTAL
-  CRYSTAL/RED
-  YELLOW/YELLOW

PAVEMENT MARKING SYMBOLS

-  PAVEMENT MARKING SYMBOLS

TEMPORARY PAVEMENT MARKING

SYMBOL	DESCRIPTION	QUANTITY
PAINT (4")		
P8	2'-6' WHITE MINI-SKIP	68 LF
PA	WHITE EDGE LINE	6000 LF
PI	YELLOW DOUBLE CENTER	6000 LF

APPROVED:  DATE: 5/5/2022 SEAL 		ROADWAY STANDARD DRAWINGS & LEGEND
DOCUMENT NOT CONSIDERED FINAL UNLESS ALL SIGNATURES COMPLETED		

GENERAL NOTES

CHANGES MAY BE REQUIRED WHEN PHYSICAL DIMENSIONS IN THE DETAIL DRAWINGS, STANDARD DETAILS, AND ROADWAY DETAILS ARE NOT ATTAINABLE TO MEET FIELD CONDITIONS OR RESULT IN DUPLICATE OR UNDESIRED OVERLAPPING OF DEVICES. MODIFICATION MAY INCLUDE: MOVING, SUPPLEMENTING, COVERING, OR REMOVAL OF DEVICES AS DIRECTED BY THE ENGINEER.

THE FOLLOWING GENERAL NOTES APPLY AT ALL TIMES FOR THE DURATION OF THE CONSTRUCTION PROJECT EXCEPT WHEN OTHERWISE NOTED IN THE PLAN OR AS DIRECTED BY THE ENGINEER

TIME RESTRICTIONS

- | | | |
|----|-----------|---------------------------------------------------------------------------------|
| A) | ROAD NAME | DAY AND TIME RESTRICTION |
| | NC 55 | MONDAY THROUGH FRIDAY
FROM 7:00 AM TO 8:00 AM AND
FROM 5:00 PM TO 6:00 PM |

- B) DO NOT CLOSE OR NARROW TRAVEL LANES DURING HOLIDAYS AND SPECIAL EVENTS AS FOLLOWS:

ROAD NAME:

NC 55

HOLIDAY

1. FOR ANY UNEXPECTED OCCURRENCE THAT CREATES UNUSUALLY HIGH TRAFFIC VOLUMES, AS DIRECTED BY THE ENGINEER.
2. FOR NEW YEAR'S DAY, BETWEEN THE HOURS OF 7:00 AM DECEMBER 31ST AND 6:00 PM JANUARY 2ND. IF NEW YEAR'S DAY IS ON A FRIDAY, SATURDAY, SUNDAY OR MONDAY THEN UNTIL 6:00 PM THE FOLLOWING TUESDAY.
3. FOR EASTER, BETWEEN THE HOURS OF 7:00 AM THURSDAY AND 6:00 PM TUESDAY
4. FOR MEMORIAL DAY, BETWEEN THE HOURS OF 7:00 AM THE THURSDAY BEFORE MEMORIAL DAY AND 6:00 PM THE TUESDAY AFTER MEMORIAL DAY.
5. FOR THE WEEK OF INDEPENDENCE DAY, BEGINNING 7:00 AM THE THURSDAY BEFORE INDEPENDENCE DAY TO 6:00 PM THE FIRST TUESDAY AFTER INDEPENDENCE DAY.
6. FOR LABOR DAY, BETWEEN THE HOURS OF 7:00 AM THE THURSDAY BEFORE LABOR DAY TO 6:00 PM THE TUESDAY AFTER LABOR DAY
7. FOR THANKSGIVING DAY, BETWEEN THE HOURS OF 7:00 AM TUESDAY TO 6:00 PM MONDAY.
8. FOR CHRISTMAS DAY, BETWEEN THE HOURS OF 7:00 AM THE FRIDAY BEFORE THE WEEK OF CHRISTMAS DAY AND 8:00 AM THE FOLLOWING TUESDAY AFTER THE WEEK OF CHRISTMAS.
9. FOR THE "PAMLICO COUNTY CROAKER FESTIVAL", BETWEEN THE HOURS OF 5:00 PM THE THURSDAY BEFORE THE FESTIVAL TO 8:00 AM THE MONDAY AFTER THE FESTIVAL

LANE AND SHOULDER CLOSURE REQUIREMENTS

- C) REMOVE LANE CLOSURE DEVICES FROM THE LANE WHEN WORK IS NOT BEING PERFORMED BEHIND THE LANE CLOSURE OR WHEN A LANE CLOSURE IS NO LONGER NEEDED OR AS DIRECTED BY THE ENGINEER.
- D) WHEN PERSONNEL AND/OR EQUIPMENT ARE WORKING WITHIN 15 FT OF AN OPEN TRAVEL LANE, CLOSE THE NEAREST OPEN SHOULDER USING ROADWAY STANDARD DRAWING NO. 1101.04 UNLESS THE WORK AREA IS PROTECTED BY BARRIER OR GUARDRAIL OR A LANE CLOSURE IS INSTALLED.
- E) WHEN PERSONNEL AND/OR EQUIPMENT ARE WORKING ON THE SHOULDER WITHIN 5 FT ADJACENT TO AN UNDIVIDED FACILITY AND WITHIN 5 FT OF AN OPEN TRAVEL LANE, CLOSE THE NEAREST TRAVEL LANE USING ROADWAY STANDARD DRAWING NO. 1101.02 UNLESS THE WORK AREA IS PROTECTED BY BARRIER OR GUARDRAIL.
- F) WHEN PERSONNEL AND/OR EQUIPMENT ARE WORKING WITHIN A LANE OF TRAVEL OF AN UNDIVIDED OR DIVIDED FACILITY, CLOSE THE LANE ACCORDING TO THE TRAFFIC CONTROL PLANS, ROADWAY STANDARD DRAWINGS, OR AS DIRECTED BY THE ENGINEER. CONDUCT THE WORK SO THAT ALL PERSONNEL AND/OR EQUIPMENT REMAIN WITHIN THE CLOSED TRAVEL LANE.
- G) DO NOT WORK SIMULTANEOUSLY WITHIN 15 FT ON BOTH SIDES OF AN OPEN TRAVELWAY, RAMP, OR LOOP WITHIN THE SAME LOCATION UNLESS PROTECTED WITH GUARDRAIL OR BARRIER.

PAVEMENT EDGE DROP OFF REQUIREMENTS



- H) BACKFILL AT A 6:1 SLOPE UP TO THE EDGE AND ELEVATION OF EXISTING PAVEMENT IN AREAS ADJACENT TO AN OPENED TRAVEL LANE THAT HAS EDGE OF PAVEMENT DROP-OFF AS FOLLOWS:

BACKFILL DROP-OFFS THAT EXCEED 3 INCHES ON ROADWAYS WITH POSTED SPEED LIMITS OF 45 MPH OR GREATER.

BACKFILL WITH SUITABLE COMPACTED MATERIAL, AS APPROVED BY THE ENGINEER, AT NO EXPENSE TO THE DEPARTMENT.
- I) DO NOT EXCEED A DIFFERENCE OF 2 INCHES IN ELEVATION BETWEEN OPEN LANES OF TRAFFIC FOR NORMAL LIFTS OF 1.5 INCHES. INSTALL ADVANCE WARNING "UNEVEN LANES" SIGNS (W8-11) (500 FEET) IN ADVANCE AND A MINIMUM OF EVERY HALF MILE THROUGHOUT THE UNEVEN AREA.

TRAFFIC PATTERN ALTERATIONS

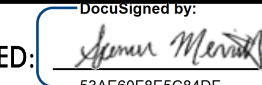
- J) NOTIFY THE ENGINEER TWENTY ONE (21) CALENDAR DAYS PRIOR TO ANY TRAFFIC PATTERN ALTERATION.

APPROVED:  DATE: 5/5/2022 SEAL 		TRANSPORTATION OPERATIONS PLAN
DOCUMENT NOT CONSIDERED FINAL UNLESS ALL SIGNATURES COMPLETED		

GENERAL NOTES

SIGNING

- K) INSTALL ADVANCE WORK ZONE WARNING SIGNS WHEN WORK IS WITHIN 40 FT FROM THE EDGE OF TRAVEL LANE AND NO MORE THAN THREE (3) DAYS PRIOR TO THE BEGINNING OF CONSTRUCTION.

- L) ENSURE ALL NECESSARY SIGNING IS IN PLACE PRIOR TO ALTERING ANY TRAFFIC PATTERN

TRAFFIC CONTROL DEVICES

- M) WHEN LANE CLOSURES ARE NOT IN EFFECT SPACE CHANNELIZING DEVICES IN WORK AREAS NO GREATER IN FEET THAN TWICE THE POSTED SPEED LIMIT (MPH), EXCEPT, 10 FT ON-CENTER IN RADII, AND 3 FT OFF THE EDGE OF AN OPEN TRAVELWAY, REFER TO STANDARD SPECIFICATIONS FOR ROADS AND STRUCTURES SECTIONS 1130 (DRUMS), 1135 (CONES) AND 1180 (SKINNY DRUMS) FOR ADDITIONAL REQUIREMENTS.

- N) PLACE TYPE III BARRICADES WITH "ROAD CLOSED" SIGN R11-2 ATTACHED OF SUFFICIENT LENGTH TO CLOSE ENTIRE ROADWAY.

PAVEMENT MARKINGS AND MARKERS

- O) INSTALL TEMPORARY PAVEMENT MARKING AND TEMPORARY PAVEMENT MARKERS ON INTERIM LAYERS OF PAVEMENT AS FOLLOWS:

ROAD NAME	MARKING	MARKER
NC 55	PAINT	TEMP RAISED

- P) PLACE ONE APPLICATION OF PAINT FOR TEMPORARY TRAFFIC PATTERNS. PLACE A SECOND APPLICATION OF PAINT SIX (6) MONTHS AFTER THE INITIAL APPLICATION AND EVERY SIX MONTHS AS DIRECTED BY THE ENGINEER.

- Q) TIE PROPOSED PAVEMENT MARKING LINES TO EXISTING PAVEMENT MARKING LINES.

- R) REMOVE/REPLACE ANY CONFLICTING/DAMAGED PAVEMENT MARKINGS AND MARKERS BY THE END OF EACH DAY'S OPERATION.

APPROVED: DATE: 5/5/2022 SEAL		 DIVISION OF HIGHWAYS DEPARTMENT OF TRANSPORTATION WORK ZONE TRAFFIC CONTROL
TRANSPORTATION OPERATIONS PLAN		
DOCUMENT NOT CONSIDERED FINAL UNLESS ALL SIGNATURES COMPLETED		

SHORING NOTES

TEMPORARY SHORING NO. 1

FOR TEMPORARY SHORING AND POSITIVE PROTECTION FOR TEMPORARY SHORING, SEE PLANS AND TEMPORARY SHORING PROVISION.

BEFORE BEGINNING TEMPORARY SHORING DESIGN OR CONSTRUCTION, SURVEY EXISTING GROUND ELEVATIONS IN THE VICINITY OF SHORING LOCATIONS TO DETERMINE ACTUAL SHORING HEIGHTS.

DESIGN TEMPORARY SHORING FROM STATION -LDET- 12+80.00±, 23' RT, TO STATION -LDET- 15+40.00±, 23' RT, FOR THE FOLLOWING ASSUMED SOIL PARAMETERS AND GROUNDWATER ELEVATION:

ELEVATIONS	ABOVE EL. -10.0 FT.	BELOW EL. -10.0 FT.
UNIT WEIGHT (γ)	100 LB/CF	120 LB/CF
FRICTION ANGLE (ϕ)	27 DEGREES	30 DEGREES
COHESION (c)	0 LB/SF	0 LB/SF
GROUNDWATER ELEV	1.5 FT±	

DO NOT USE A TEMPORARY GEOTEXTILE WALL FOR TEMPORARY SHORING FROM STATION -LDET- 12+80.00±, 23' RT, TO STATION -LDET- 15+40.00±, 23' RT.

DO NOT USE A STANDARD SHORING FOR TEMPORARY SHORING FROM STATION -LDET- 12+80.00±, 23' RT, TO STATION -LDET- 15+40.00±, 23' RT.

TEMPORARY SHORING NO. 2

FOR TEMPORARY SHORING AND POSITIVE PROTECTION FOR TEMPORARY SHORING, SEE PLANS AND TEMPORARY SHORING PROVISION.

BEFORE BEGINNING TEMPORARY SHORING DESIGN OR CONSTRUCTION, SURVEY EXISTING GROUND ELEVATIONS IN THE VICINITY OF SHORING LOCATIONS TO DETERMINE ACTUAL SHORING HEIGHTS.

DESIGN TEMPORARY SHORING FROM STATION -LDET- 16+70.90±, 23' RT, TO STATION -LDET- 21+00.00±, 23' RT, FOR THE FOLLOWING ASSUMED SOIL PARAMETERS AND GROUNDWATER ELEVATION:

ELEVATIONS	ABOVE EL. -9.0 FT.	BELOW EL. -9.0 FT.
UNIT WEIGHT (γ)	100 LB/CF	120 LB/CF
FRICTION ANGLE (ϕ)	27 DEGREES	30 DEGREES
COHESION (c)	0 LB/SF	0 LB/SF
GROUNDWATER ELEV	1.5 FT±	

DO NOT USE A TEMPORARY GEOTEXTILE WALL FOR TEMPORARY SHORING FROM STATION -LDET- 16+70.90±, 23' RT, TO STATION -LDET- 21+00.00±, 23' RT.

DO NOT USE A STANDARD SHORING FOR TEMPORARY SHORING FROM STATION -LDET- 16+70.90±, 23' RT, TO STATION -LDET- 21+00.00±, 23' RT.

THE TEMPORARY SHORING NOTES SHOWN ON THIS SHEET WERE PROVIDED THROUGH SEALED DOCUMENTS FROM THE GEOTECHNICAL ENGINEERING UNIT. THE DOCUMENTS WERE SUBMITTED TO STRUCTURES MANAGEMENT UNIT ON APRIL 22, 2019 AND SEALED BY PROFESSIONAL ENGINEER, JINYOUNG PARK, LICENSE # 032171

25-APR-2022 15:43
B45931.TC_TMP_2.dgn
conner.mcgraw

APPROVED: DATE: 5/5/2022 <div style="text-align: center;"> </div>		<h2 style="margin: 0;">TEMPORARY SHORING NOTES</h2>
DOCUMENT NOT CONSIDERED FINAL UNLESS ALL SIGNATURES COMPLETED		

MANAGEMENT STRATEGIES

TRAFFIC WILL BE MAINTAINED ON-SITE WITH A TEMPORARY DETOUR AND BRIDGE. LANE CLOSURES ON NC 55 WILL NOT BE ALLOWED MONDAY THROUGH FRIDAY FROM 7:00 AM TO 8:00 AM AND 5:00 PM TO 6:00 PM.

PHASING

COMPLETE ANY PROPOSED WIDENING OR WEDGING IN SUCH A MANNER THAT PONDING OF WATER WILL NOT OCCUR IN THE TRAVEL LANE.

PHASE I

STEP 1:

USING ROADWAY STANDARD DRAWING NO. 1101.01 (SHEET 3 OF 3), INSTALL ALL ADVANCED WORK ZONE WARNING SIGNS.

STEP 2:

AWAY FROM TRAFFIC, CONSTRUCT AS MUCH AS POSSIBLE TEMPORARY DETOUR FROM -LDET- STA 13+00+/- TO STA 20+50+/- INCLUDING TEMPORARY SHORING SEE SHEET TMP-4

STEP 3

USING ROADWAY STANDARD DRAWING NO. 1101.02 (SHEET 1 OF 15), TRANSITION GRADE AS NEEDED TO PROVIDE TEMPORARY DETOUR TIES FROM -LDET- 10+00+/- TO 13+00+/- AND FROM -LDET- STA 20+50+/- TO STA 24+83+/-, UP TO THE EDGE AND ELEVATION OF EXISTING PAVEMENT. ADDITIONAL FLAGGERS MAY BE NEEDED AT SR 1324 (FLORENCE RD.) AND SR 1322 (N. TRENT RD.). EXPOSED GUARDRAIL SHOULD BE PROTECTED BY USING A TMA AND DRUMS ALONG THE SHOULDER NEAREST TRAFFIC AT THE END OF EACH WORK DAY UNTIL THE GUARDRAIL END UNIT IS INSTALLED.

PHASE II

STEP 1:

USING ROADWAY STANDARD DRAWING NO. 1101.02 (SHEET 1 OF 15), PLACE TEMPORARY PAVEMENT MARKINGS AND TEMPORARY RAISED PAVEMENT MARKERS ON -LDET-, SHIFT TRAFFIC TO DETOUR, AND COMPLETE GUARDRAIL AS NECESSARY. ADDITIONAL FLAGGERS MAY BE NEEDED AT SR 1324 (FLORENCE RD.) AND SR 1322 (N. TRENT RD). SEE SHEET TMP-5

STEP 2:

AWAY FROM TRAFFIC, REMOVE EXISTING BRIDGE, CONSTRUCT AND OR WEDGE PROPOSED ROADWAY FROM -L- STA 15+00+/- TO STA 19+50+/- UP TO BUT NOT INCLUDING THE FINAL SURFACE COURSE. EXPOSED GUARDRAIL SHOULD BE PROTECTED BY USING A TMA AND DRUMS ALONG THE SHOULDER NEAREST TRAFFIC AT THE END OF EACH WORK DAY UNTIL THE GUARDRAIL END UNIT IS INSTALLED. SEE SHEET TMP-6

PHASE III

STEP 1:

USING ROADWAY STANDARD DRAWING NO. 1101.02 (SHEET 1 OF 15) AND FLAGGING, WEDGE AND OR CONSTRUCT -L- STA 10+00+/- TO STA 15+00+/- AND FROM -L- STATION 19+50+/- TO STA 26+00+/- UP TO BUT NOT INCLUDING THE FINAL SURFACE COURSE. ADDITIONAL FLAGGERS MAY BE NEEDED AT SR 1324 (FLORENCE RD.) AND SR 1322 (N. TRENT RD.).

STEP 2:



USING ROADWAY STANDARD DRAWING NO. 1101.02 (SHEET 1 OF 15), PLACE TEMPORARY PAVEMENT MARKINGS AND TEMPORARY RAISED PAVEMENT MARKERS ON PROPOSED -L- AND SHIFT TRAFFIC TO FINAL PATTERN. ADDITIONAL FLAGGERS MAY BE NEEDED AT SR 1324 (FLORENCE RD.) AND SR 1322 (N. TRENT RD). COMPLETE ANY NECESSARY GUARDRAIL INSTALLATION. SEE SHEET TMP-7

STEP 3:

REMOVE TEMPORARY BRIDGE AND DETOUR INCLUDING TEMPORARY SHORING. USE ROADWAY STANDARD DRAWING 1101.02 (SHEET 1 OF 15) WHEN WORK IS WITHIN 5 FEET OF TRAFFIC.

STEP 4:

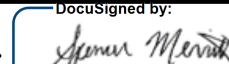
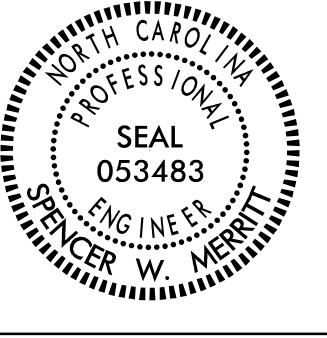
USING ROADWAY STANDARD DRAWING NO. 1101.02 (SHEET 1 OF 15), PLACE THE FINAL LAYER OF SURFACE COURSE AND FINAL MARKINGS ON -L- FROM 10+00+/- TO STA 26+00+/- . TIE PROPOSE PAVEMENT MARKINGS INTO EXISTING PAVEMENT MARKINGS.

<p>APPROVED: </p> <p>DATE: 5/5/2022</p> <p style="text-align: center;">SEAL</p> <div style="text-align: center;">  </div>		<p>MANAGEMENT STRATEGIES AND PHASING</p>
<p>DOCUMENT NOT CONSIDERED FINAL UNLESS ALL SIGNATURES COMPLETED</p>		

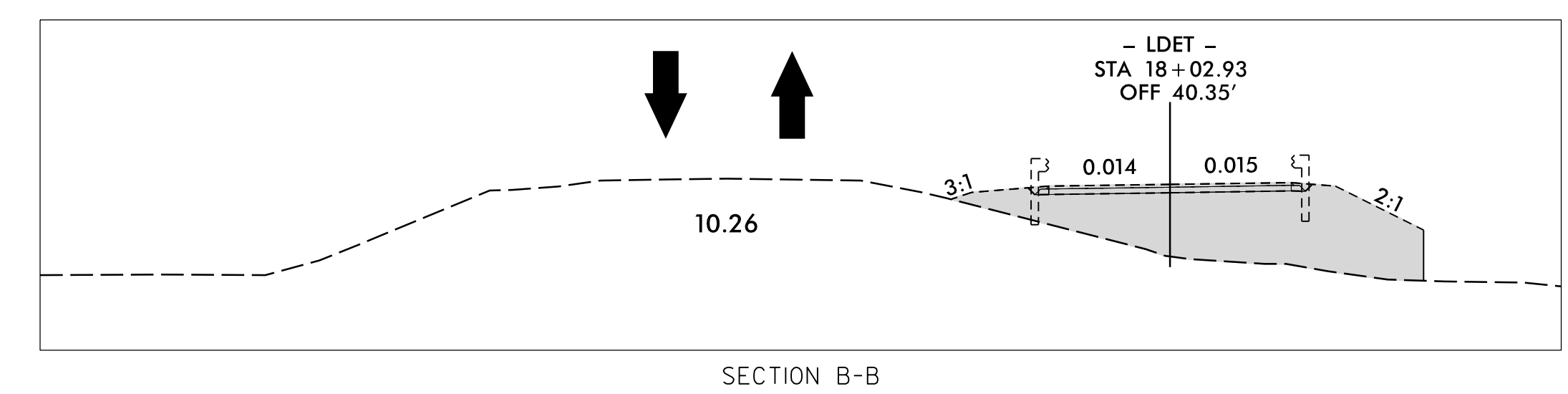
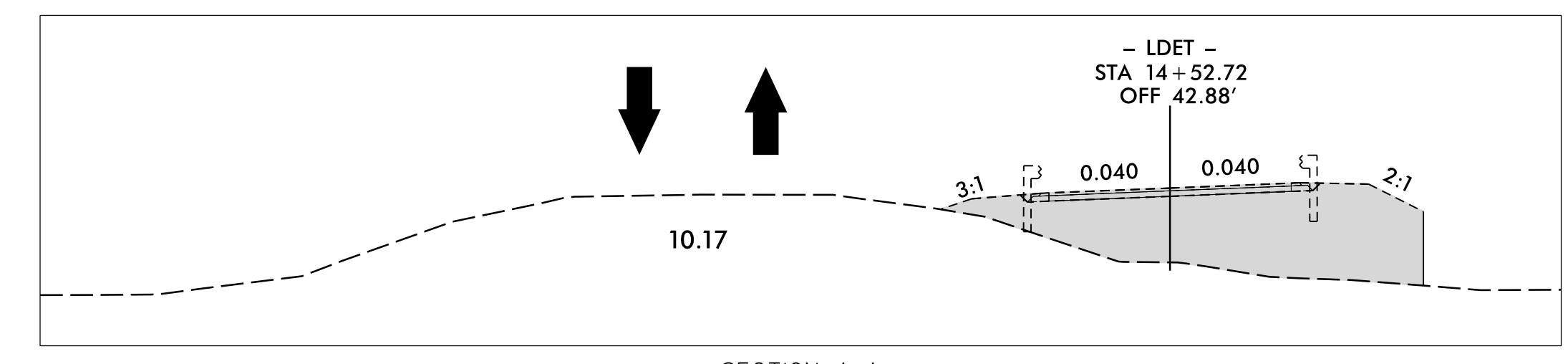
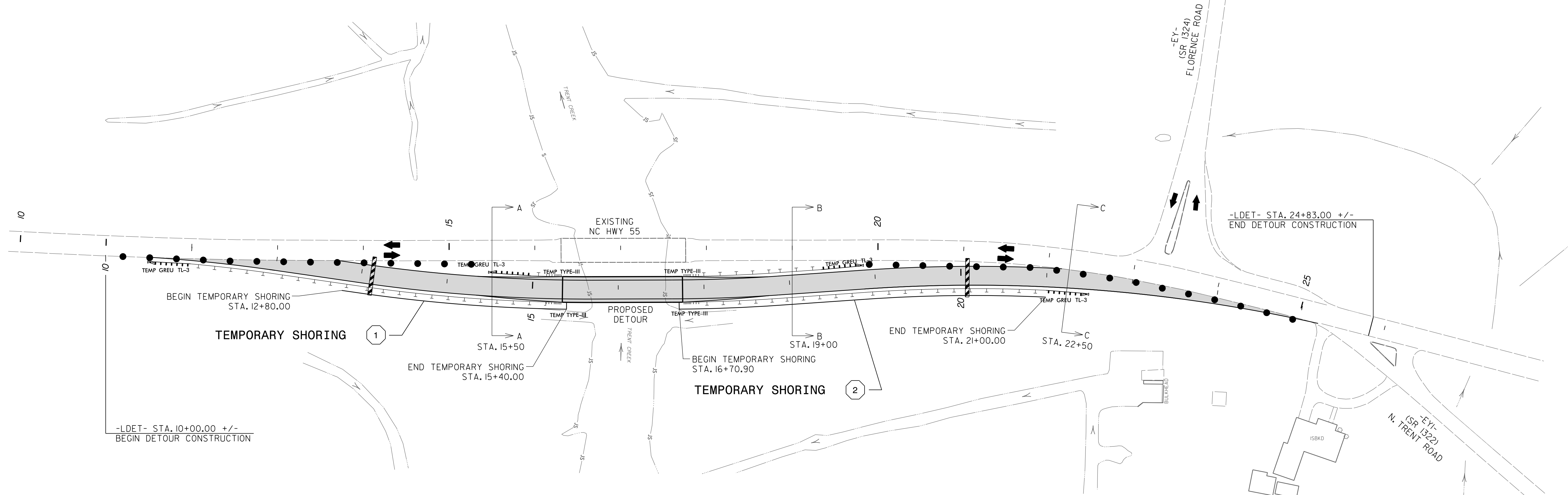
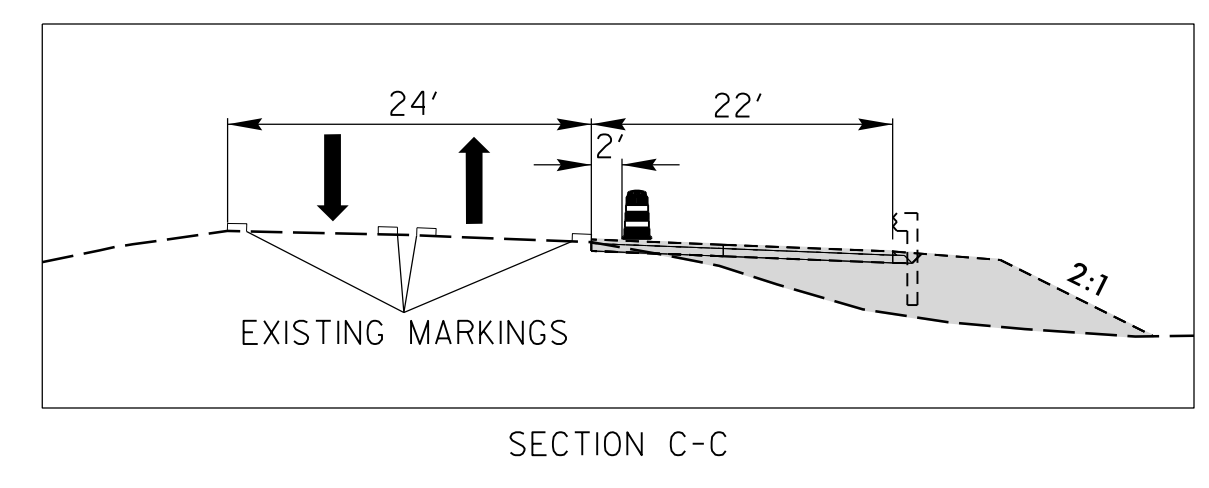
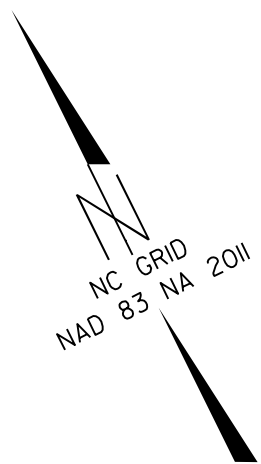

<p>1 QUANTITY = 1560 SF</p> <p>TEMPORARY SHORING FROM STA. 12+80.00, 23' RT TO STA. 15+40.00, 23' RT</p> <p>(SEE SHEET TMP-2 FOR TEMPORARY SHORING NOTES)</p>	<p>2 QUANTITY = 1846 SF</p> <p>TEMPORARY SHORING FROM STA. 16+70.90, 23' RT TO STA. 21+00.00, 23' RT</p> <p>(SEE SHEET TMP-2 FOR TEMPORARY SHORING NOTES)</p>
---------------------------------------------------------------------------------------------------------------------------------------------------------------	---------------------------------------------------------------------------------------------------------------------------------------------------------------

APPROVED:

DATE: 5/5/2022

SEAL

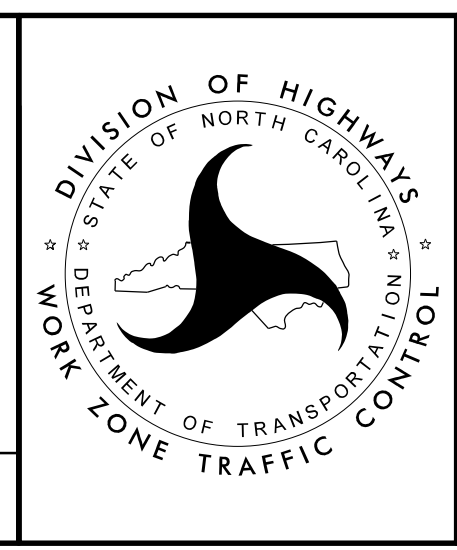

**PHASE I
STEP 2**

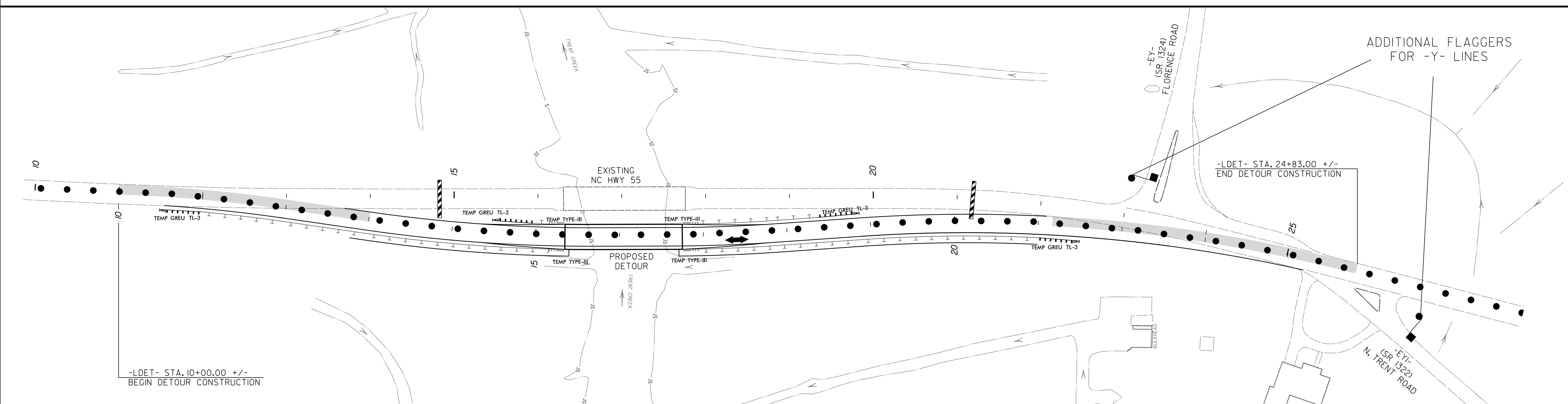
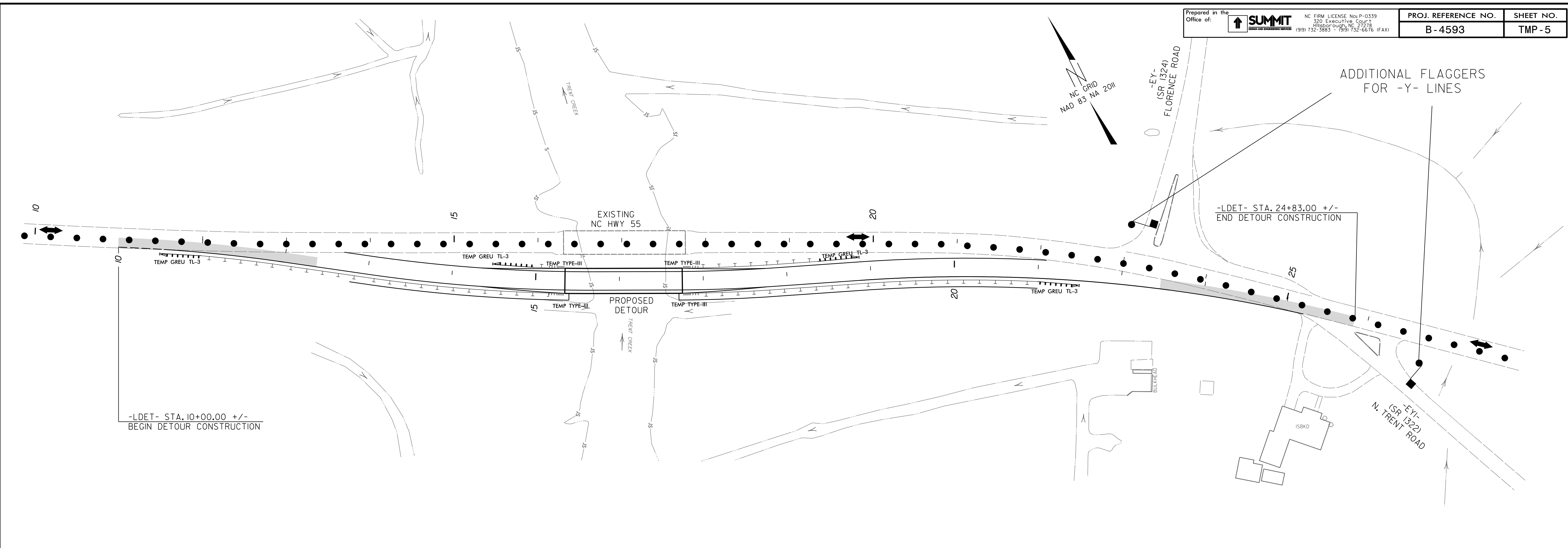

25-APR-2022 15:43
B45931_TMP_5.dgn
conner.mcgraw

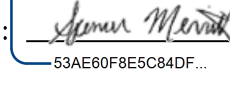
DocuSigned by:
APPROVED: 
DATE: 5/5/2022
SEAL

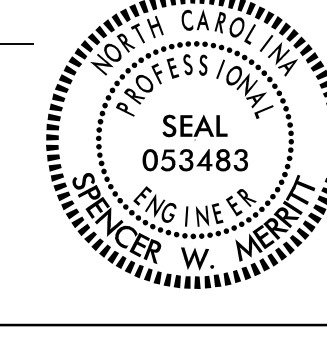

**DOCUMENT NOT CONSIDERED FINAL
UNLESS ALL SIGNATURES COMPLETED**

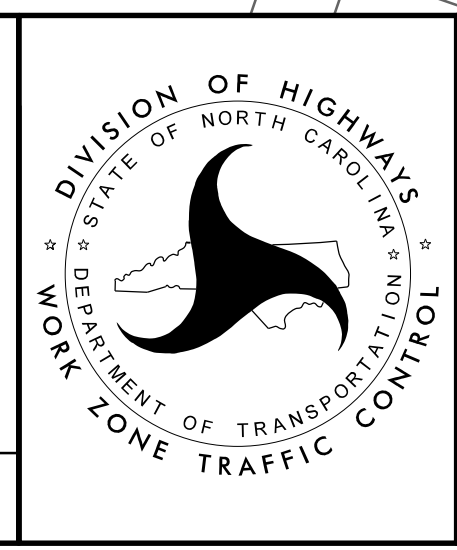

**PHASE II
STEP 1**

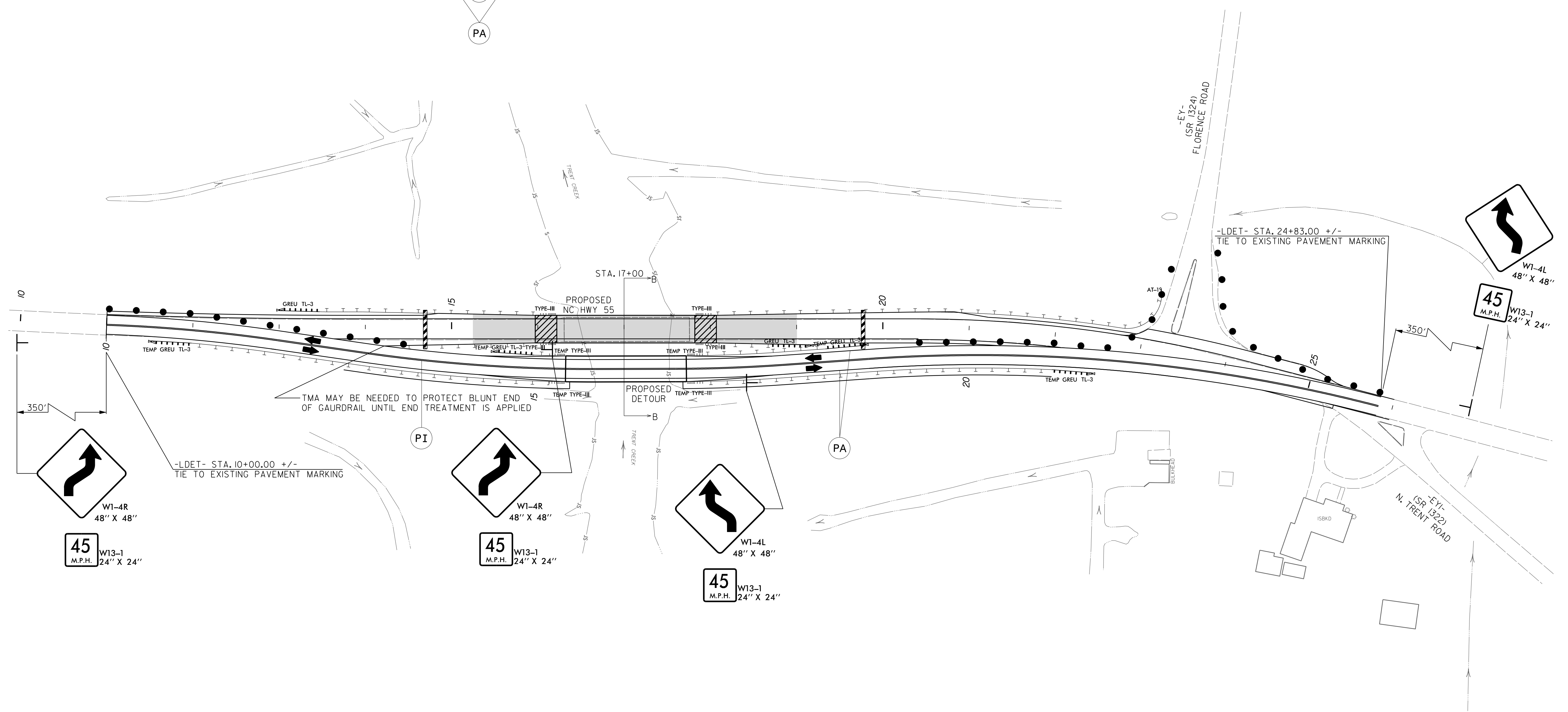
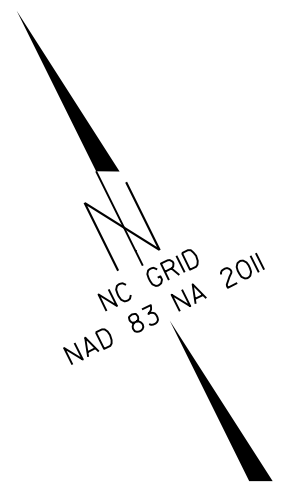
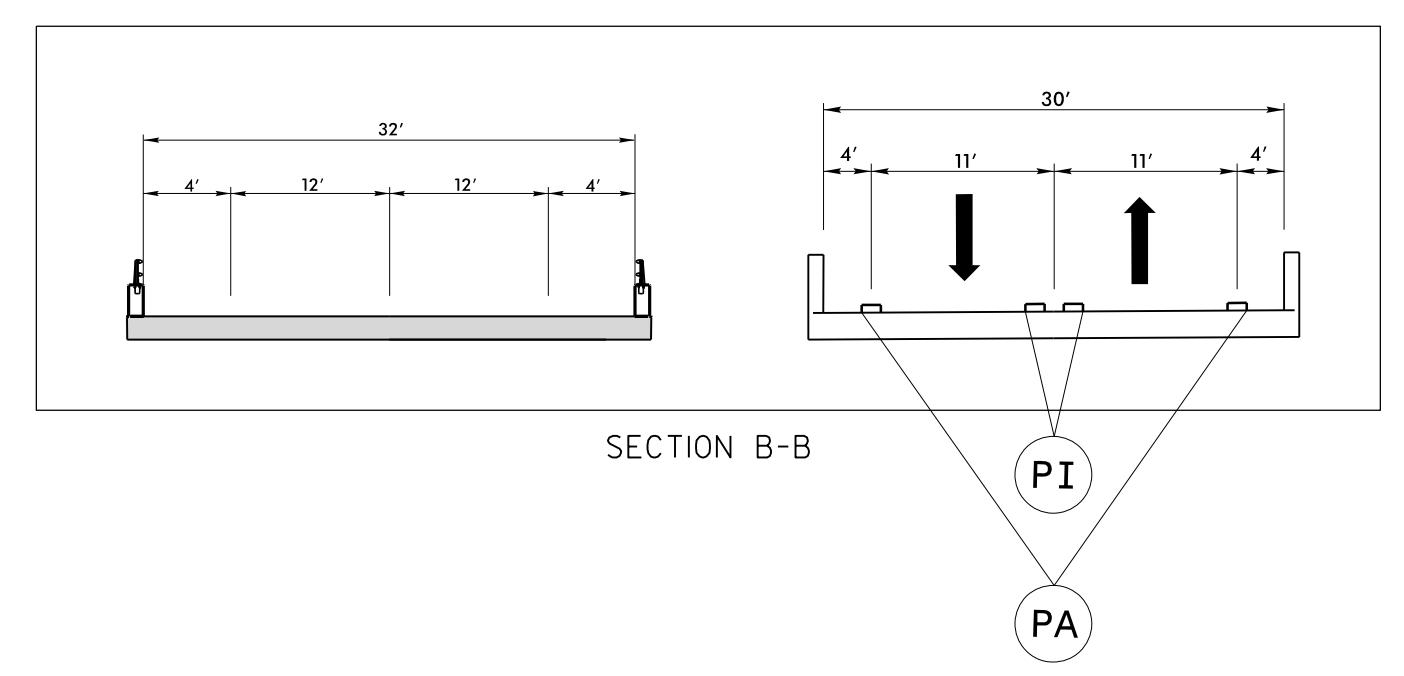

25-APR-2022 17:02
 B4593_TMP_6.dgn
 faith.jahnke

NOTE: SEE ROADWAY STANDARD DRAWING NO. 1101.03 SHEET 3 OF 9 FOR PLACEMENT W1-4R SIGNS AND RAISE PAVEMENT MARKERS

APPROVED: DATE: 5/5/2022 SEAL 		PHASE II STEP 2
DOCUMENT NOT CONSIDERED FINAL UNLESS ALL SIGNATURES COMPLETED		

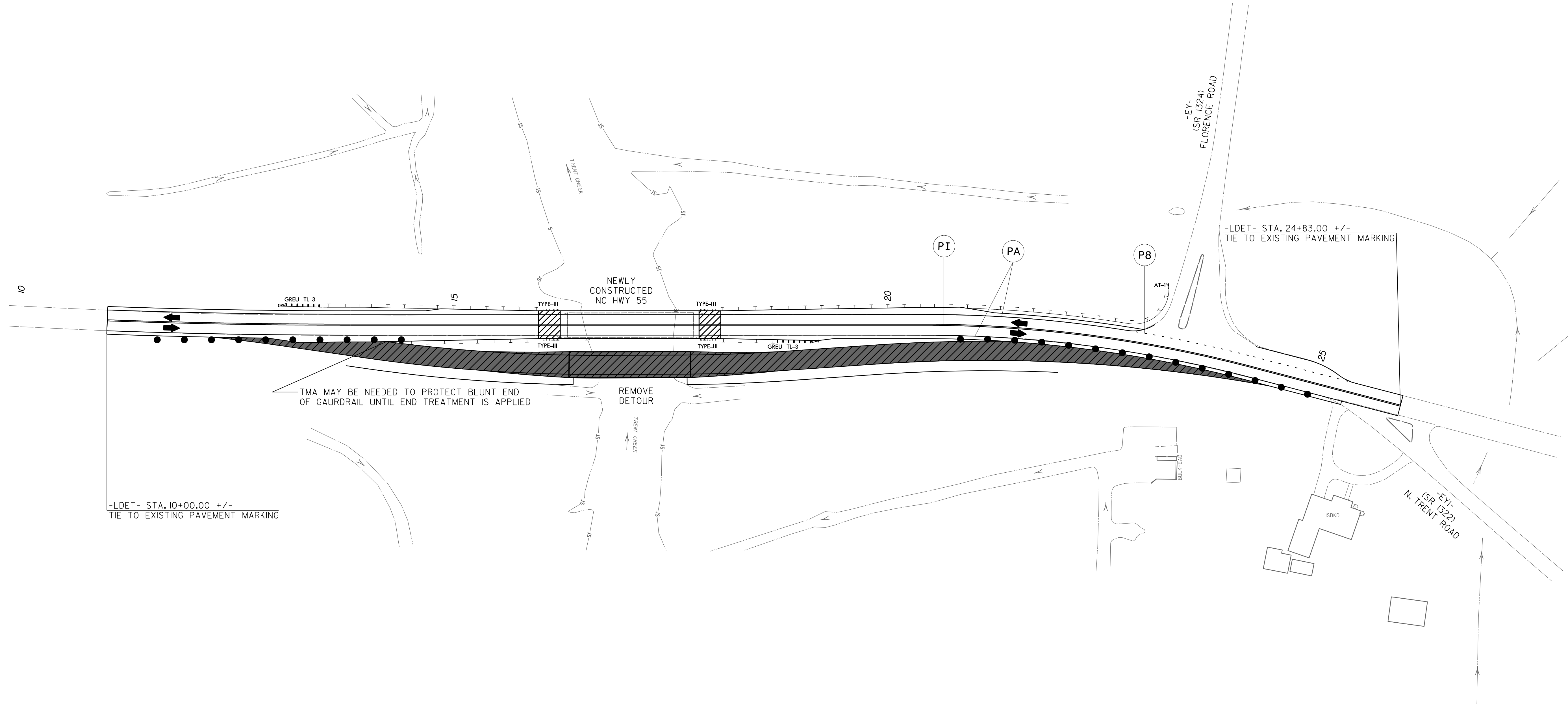
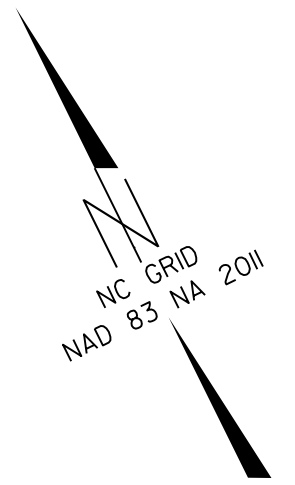

25-APR-2022 17:04
 B4593_TMP_7.dgn
 faith.jahnke

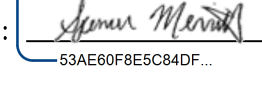
APPROVED: 
SSAEO6PRESCB4DF...

DATE: 5/5/2022

SEAL

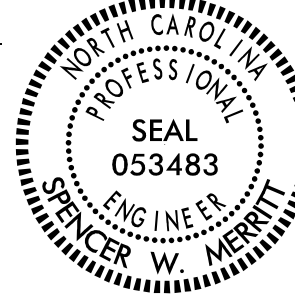

**DOCUMENT NOT CONSIDERED FINAL
 UNLESS ALL SIGNATURES COMPLETED**

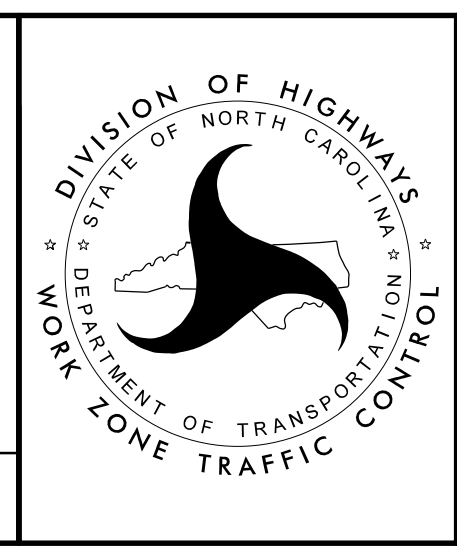

PHASE III