

ELEVATION

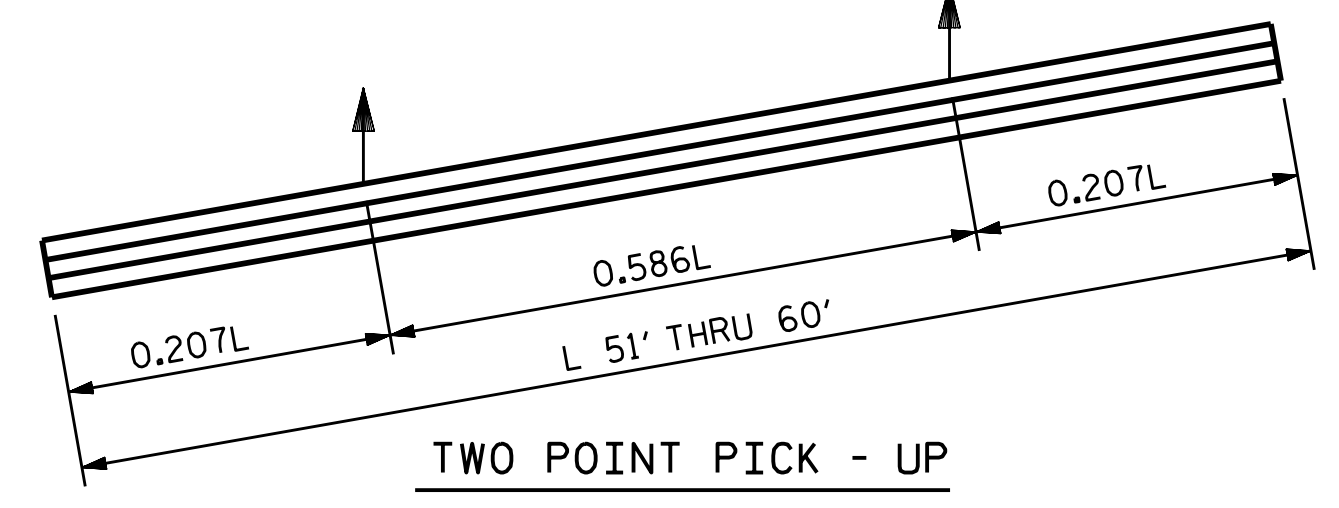
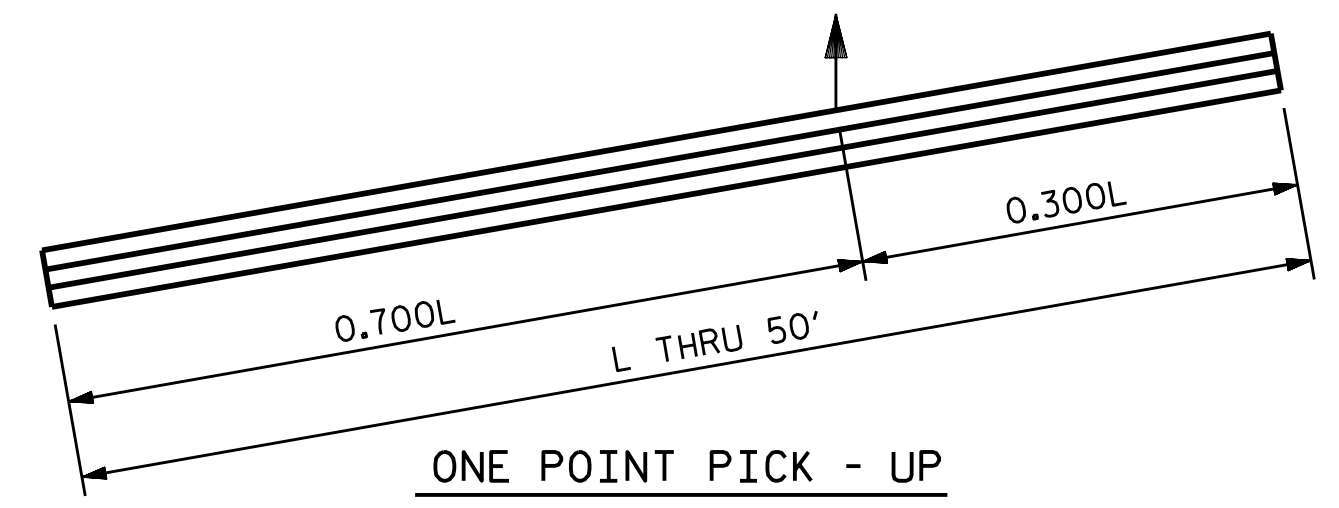

PICK - UP POINTS

NOTES

CONCRETE DESIGN DATA :  $f'_c = 5,000$  PSI

PROPOSED DEVICES FOR LIFTING PILES, RECESS DETAILS, AND PATCHING MATERIAL SHALL BE DETAILED IN SHOP DRAWINGS. AFTER ATTACHMENTS HAVE BEEN REMOVED, OPENINGS SHALL BE REPAIRED SUCH THAT THE APPEARANCE OF THE PILE IS UNIFORM.

WHERE CAST-IN-PLACE LIFTING DEVICES ARE NOT USED, PICK-UP POINTS TO BE INDICATED WITH A BLACK MARK 2" WIDE.

THE SLIP-FORM METHOD OF CASTING PILES WILL NOT BE PERMITTED.

ALL CORNERS TO BE CHAMFERED 1".

LENGTH	APPROX. PILE WT. TONS	ONE PICK-UP POINT		TWO PICK-UP POINT	
		0.300L	0.700L	0.207L	0.586L
10'-0"	1.56	3'-0"	7'-0"		
15'-0"	2.35	4'-6"	10'-6"		
20'-0"	3.14	6'-0"	14'-0"		
25'-0"	3.93	7'-6"	17'-6"		
30'-0"	4.70	9'-0"	21'-0"		
35'-0"	5.49	10'-6"	24'-6"		
40'-0"	6.28	12'-0"	28'-0"		
45'-0"	7.05	13'-6"	31'-6"		
50'-0"	7.84	15'-0"	35'-0"		
55'-0"	8.63			11'-4 1/2"	32'-3"
60'-0"	9.42			12'-5"	35'-2"

BAR TYPES

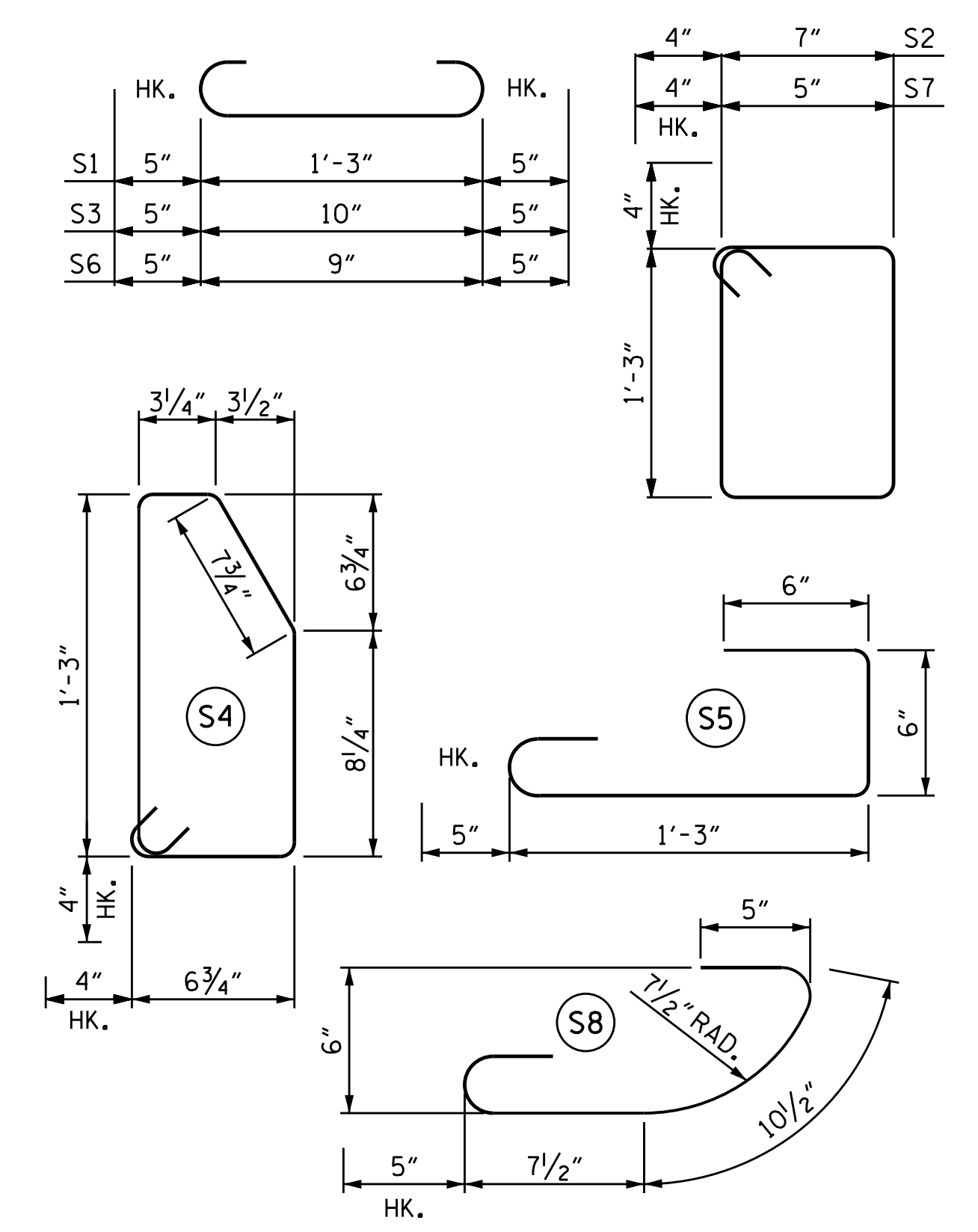

ALL BAR DIMENSIONS ARE OUT TO OUT.

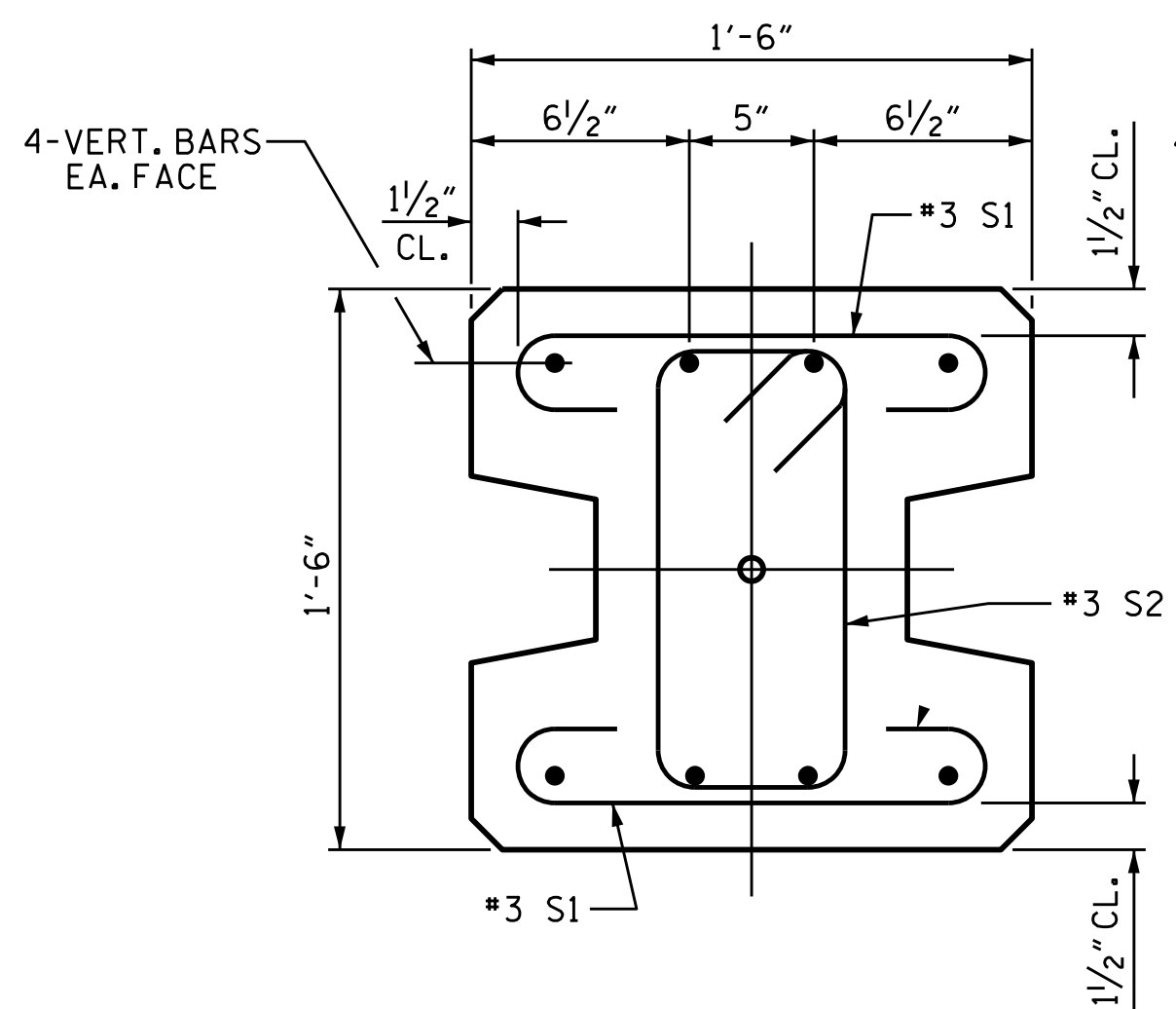

TYPE - I

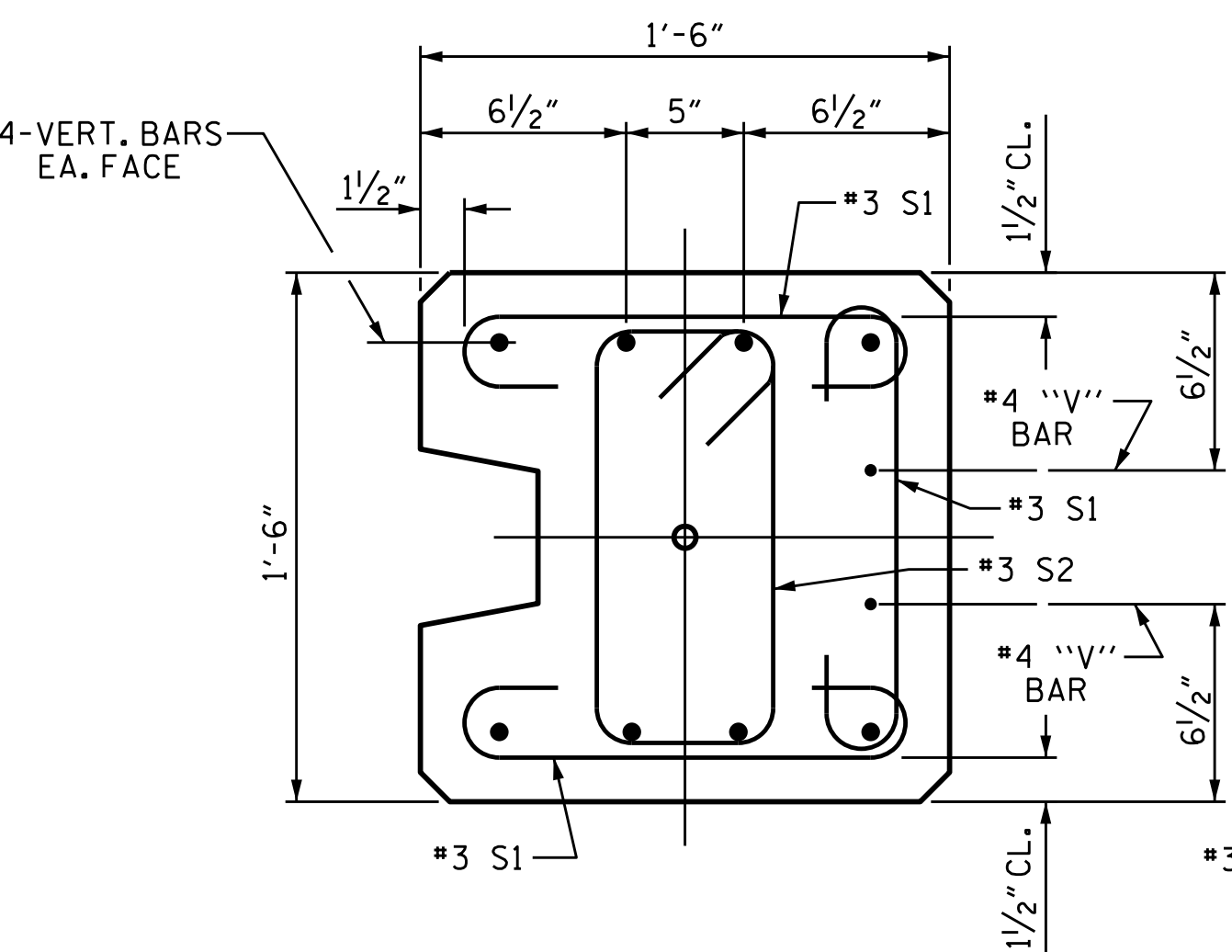

TYPE - II

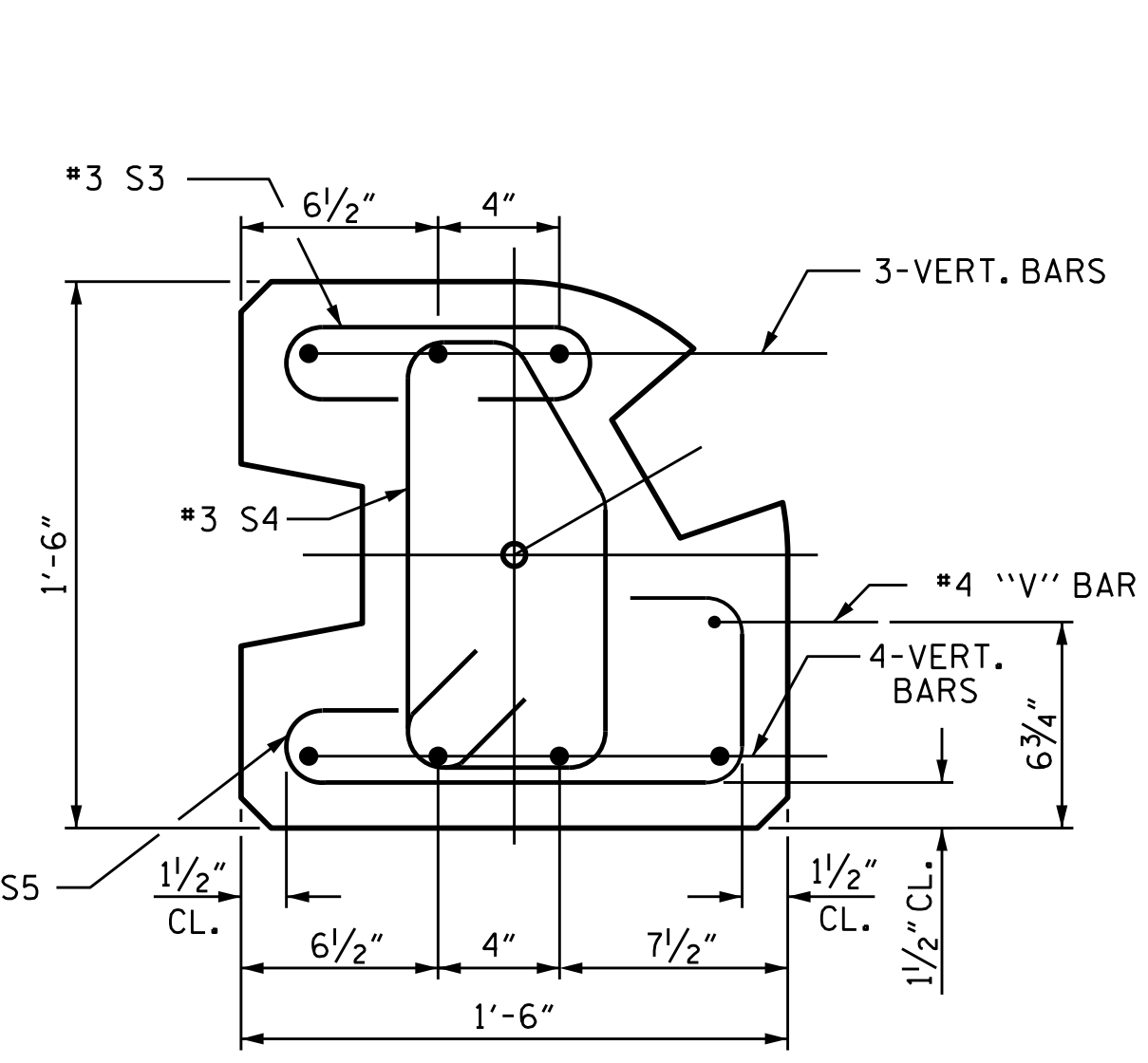

TYPE - III

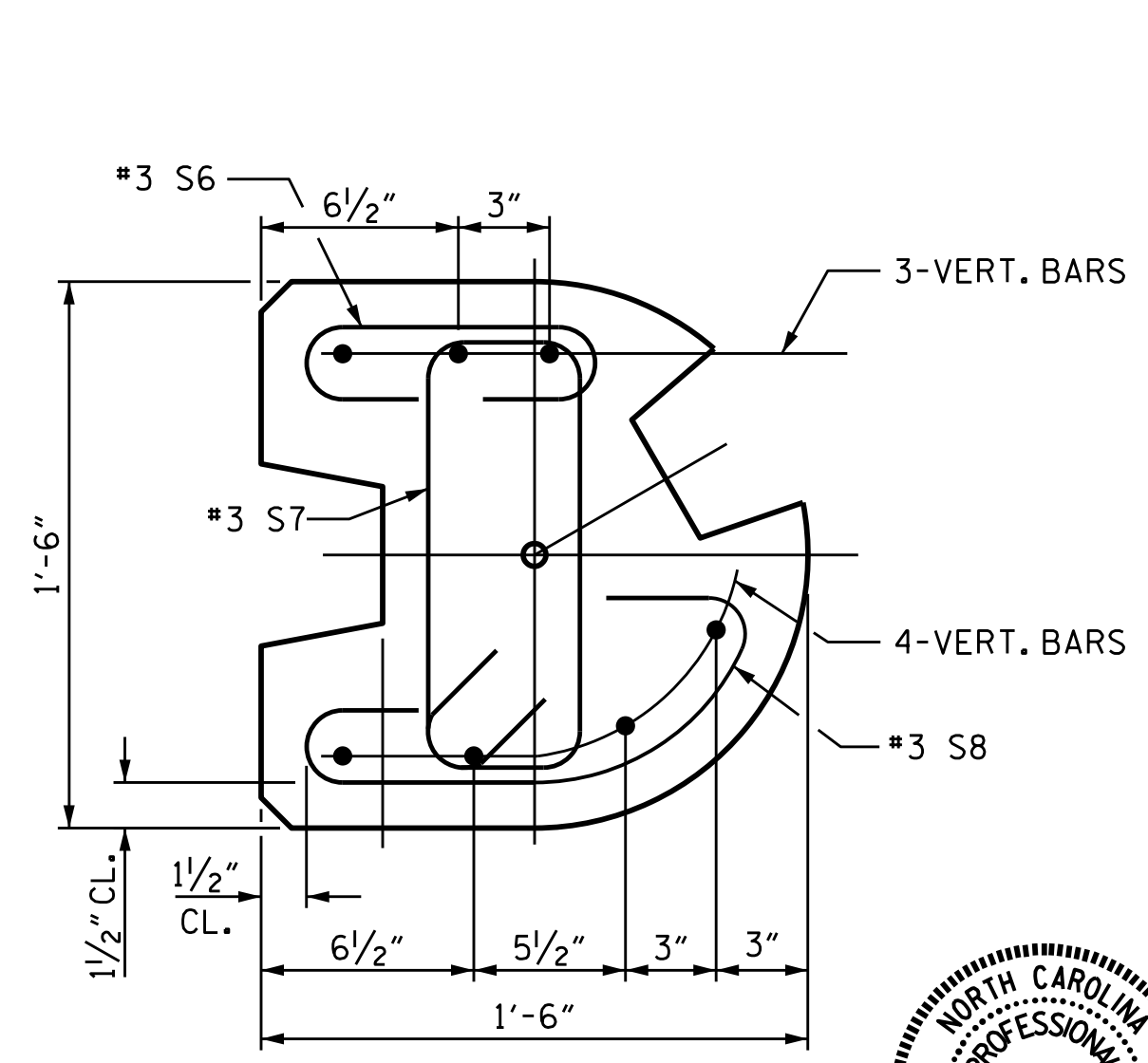

TYPE - III (ALT.)

PILE DETAIL

FOR VERTICAL BAR PILE REINFORCING, SEE SHEET 1 OF 3

PROJECT NO. U-6223  
 JOHNSTON COUNTY  
 STATION: 50+94.38 -L-

SHEET 3 OF 3

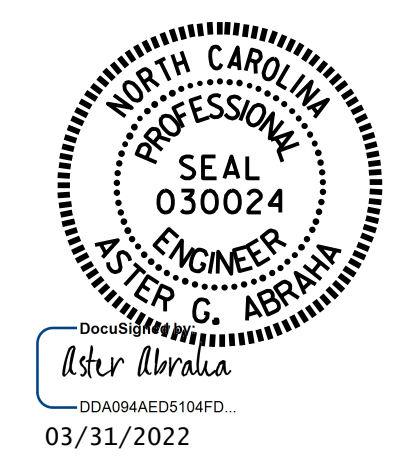

STATE OF NORTH CAROLINA  
 DEPARTMENT OF TRANSPORTATION  
 RALEIGH

SOUND BARRIER WALL  
 DETAILS

ASSEMBLED BY : M.M. AHMED	DATE : 11/2021
CHECKED BY : A. ABRAHA	DATE : 12/2021
DRAWN BY : MAA 6/11	REV. 1/15/14 RWW/TMG
CHECKED BY : GM 6/11	REV. 12/17 MAA/THC

REVISIONS						SHEET NO.
NO.	BY:	DATE:	NO.	BY:	DATE:	NW-3
1			3			TOTAL SHEETS
2			4			3

DOCUMENT NOT CONSIDERED FINAL UNLESS ALL SIGNATURES COMPLETED