

# JOHNSTON COUNTY DETAILS

PREPARED IN THE OFFICE OF:

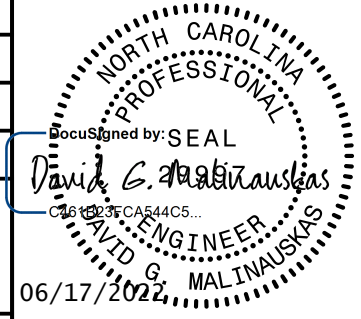

120 North Boylan Avenue Raleigh, NC 27603-1423  
919.828.0531 Fax 919.834.3559  
License Number: F-0115

PROJECT REFERENCE NO.	U-6223	SHEET NO.	UC-3B
DESIGNED BY:	CMG		
DRAWN BY:	TK		
CHECKED BY:	DGM		
APPROVED BY:	CMG		
REVISÉD:	NORTH CAROLINA DEPARTMENT OF TRANSPORTATION		
UTILITIES ENGINEERING SEC. PHONE: (919) 707-6690 FAX: (919) 250-4151			

06/17/2008  
Document Not Considered Final Unless All Signatures Completed  
UTILITY CONSTRUCTION PLANS ONLY

## UTILITY CONSTRUCTION

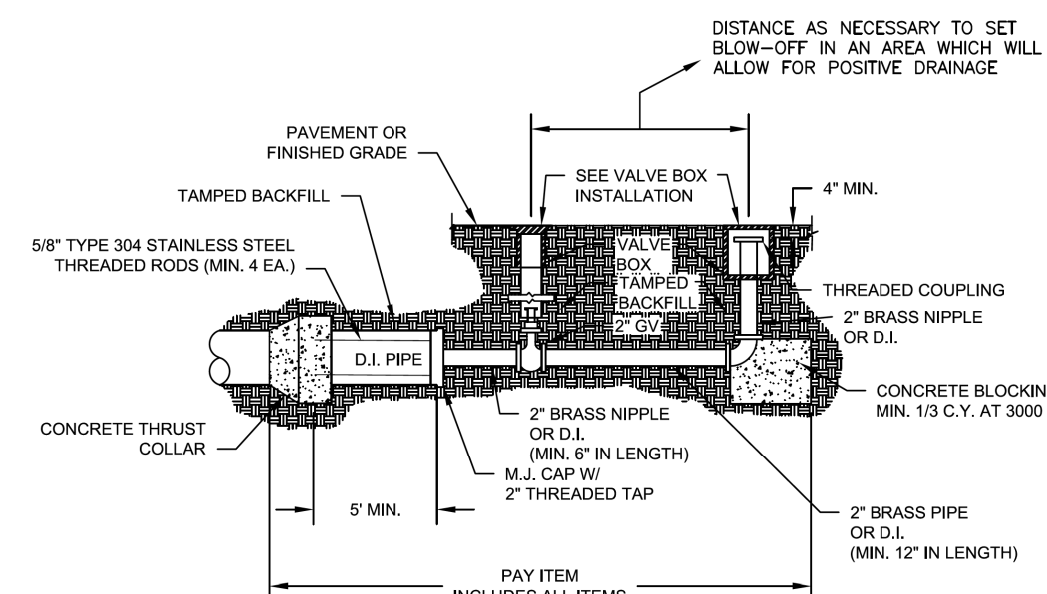

**PERMANENT BLOW-OFF ASSEMBLY**  
NOT TO SCALE

NOTE:  
1) THE TOP OF THE BLOW-OFF STANDPIPE SHALL BE NO MORE THAN 4'-6" BELOW GRADE.  
2) BLOW-OFFS SHALL BE LOCATED IN AREAS WHICH WILL ALLOW FOR POSITIVE DRAINAGE WHEN UTILIZED.  
3) ALL MATERIALS USED IN THE POTABLE WATER SYSTEM MUST BE NSF61 AND NSF372 CERTIFIED AND MEET THE LATEST FEDERAL SAFE DRINKING WATER ACT REQUIREMENTS.

Drawn By:	Name	Date		<b>JOHNSTON COUNTY</b> Department of Public Utilities P.O. Box 2263 Smithfield, NC 27577	<b>WATER STANDARD DETAIL</b> Permanent Blow Off Assembly	PAGE <b>2</b>
Checked By:						
Approved By:						
Scale:						
Rev.	Description	Date	Int.			

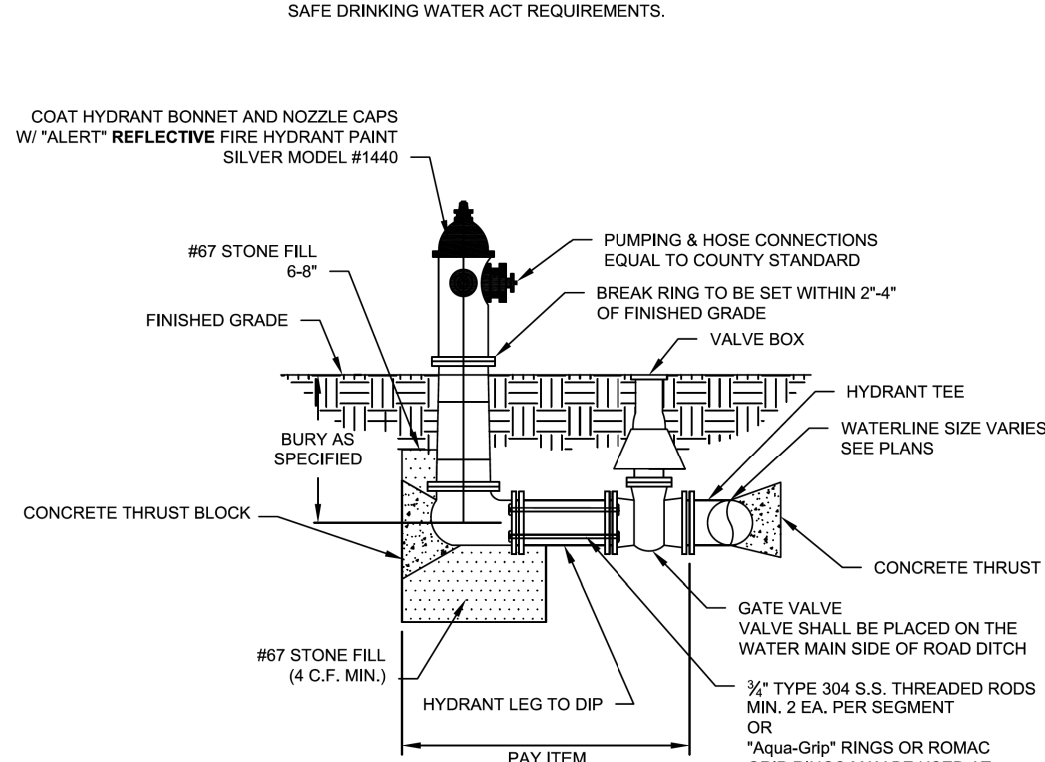

**FIRE HYDRANT ASSEMBLY**  
NOT TO SCALE

NOTE:  
1. MIN. OF 4 CU. FT. STONE (MORE IF REQ'D).  
2. CONC. THRUST BLOCK TO HAVE MIN. OF 6 SQ. FT. BEARING ON SOLID BANK (MORE IF REQ'D).  
3. DRAIN HOLES AND FLANGES SHALL BE CLEAR OF CONC.  
4. FIRE HYDRANT BARREL SHALL BE PLUMB.  
5. ALL MATERIALS USED IN THE POTABLE WATER SYSTEM MUST BE NSF61 AND NSF372 CERTIFIED AND MEET THE LATEST FEDERAL SAFE DRINKING WATER ACT REQUIREMENTS.

"FIRE HYDRANTS INSTALLED ON EXISTING 6" WATER MAINS, MUST BE INSTALLED USING A 6"x6" TEE CUT INTO THE EXISTING WATER MAIN. FIRE HYDRANTS INSTALLED ON EXISTING WATER MAINS LARGER THAN 6", CAN BE INSTALLED USING A TAPPING SLEEVE AND VALVE ON THE EXISTING WATER MAIN.

Drawn By:	Name	Date		<b>JOHNSTON COUNTY</b> Department of Public Utilities P.O. Box 2263 Smithfield, NC 27577	<b>WATER STANDARD DETAIL</b> Fire Hydrant Assembly	PAGE <b>4</b>
Checked By:						
Approved By:						
Scale:						
Rev.	Description	Date	Int.			

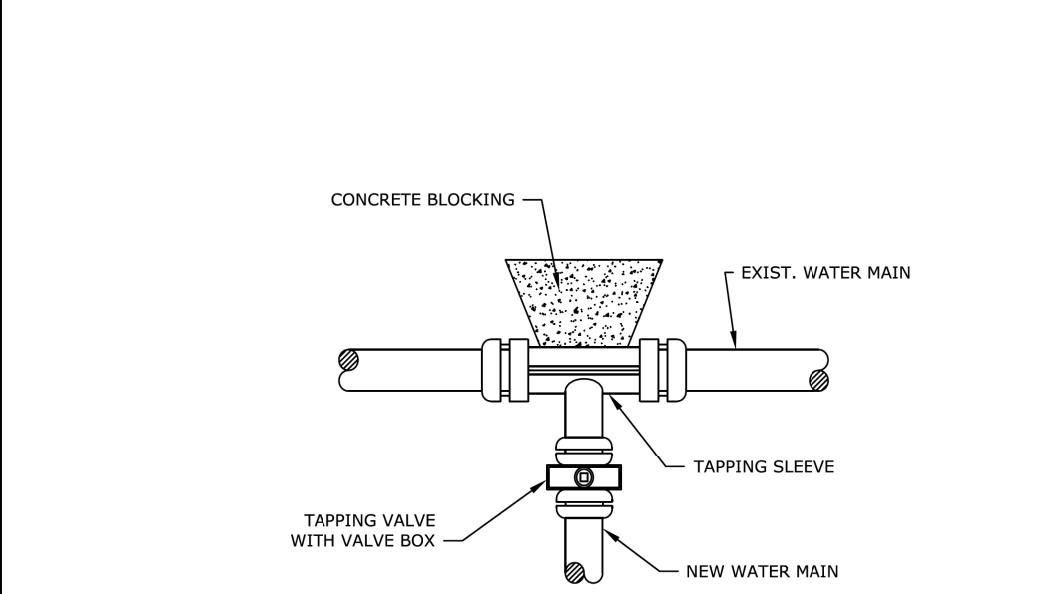

**TAPPING SLEEVE & VALVE ASSEMBLY**  
NOT TO SCALE

NOTE:  
1. TAPPING SLEEVE SHALL BE FABRICATED OF TYPE 304 OR 316 S.S. AND PROVIDE A 360° SEAL AROUND EXISTING PIPE WITH FULL CIRCUMFERENTIAL GASKET.  
2. TAPPING SLEEVE SHALL BE JCM 432, MUELLER H-304, FORD FTSS, ROMAC ST III OR APPROVED EQUAL.  
3. ALL MATERIALS USED IN THE POTABLE WATER SYSTEM MUST BE NSF61 AND NSF372 CERTIFIED AND MEET THE LATEST FEDERAL SAFE DRINKING WATER ACT REQUIREMENTS.

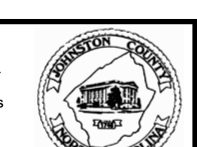
Drawn By:	Name	Date		<b>JOHNSTON COUNTY</b> Department of Public Utilities P.O. Box 2263 Smithfield, NC 27577	<b>WATER STANDARD DETAIL</b> Tapping Sleeve and Valve Assembly	PAGE <b>5</b>
Checked By:						
Approved By:						
Scale:						
Rev.	Description	Date	Int.			

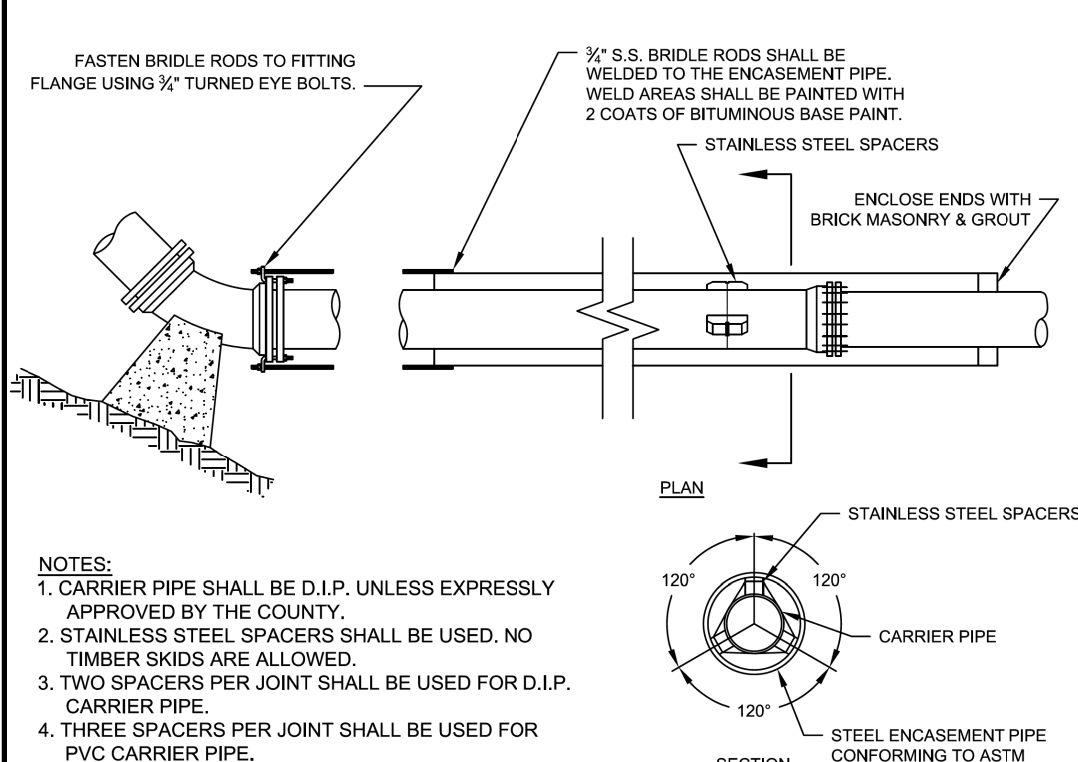

**STANDARD BORE ENCASEMENT**  
NOT TO SCALE

NOTE:  
1. CARRIER PIPE SHALL BE D.I.P. UNLESS EXPRESSLY APPROVED BY THE COUNTY.  
2. STAINLESS STEEL SPACERS SHALL BE USED. NO TIMBER SKIDS ARE ALLOWED.  
3. TWO SPACERS PER JOINT SHALL BE USED FOR D.I.P. CARRIER PIPE.  
4. THREE SPACERS PER JOINT SHALL BE USED FOR PVC CARRIER PIPE.  
5. ENCASED BORES ALONG GRAVITY COLLECTION SYSTEMS SHALL NOT REQUIRE BRIDLE RODS.  
6. 2 EA. 3/4" S.S. BRIDLE RODS SHALL BE REQUIRED ON ALL LINES 8"Ø AND SMALLER. 4 EA. 3/4" S.S. BRIDLE RODS SHALL BE REQUIRED ON ALL LINES 10"Ø AND LARGER.  
7. CARRIER PIPE SHALL BE INSTALLED USING FIELD 'LOK' GASKETS OR APPROVED EQUAL.

Drawn By:	Name	Date		<b>JOHNSTON COUNTY</b> Department of Public Utilities P.O. Box 2263 Smithfield, NC 27577	<b>WATER STANDARD DETAIL</b> Standard Bore Encasement	PAGE <b>6</b>
Checked By:						
Approved By:						
Scale:						
Rev.	Description	Date	Int.			

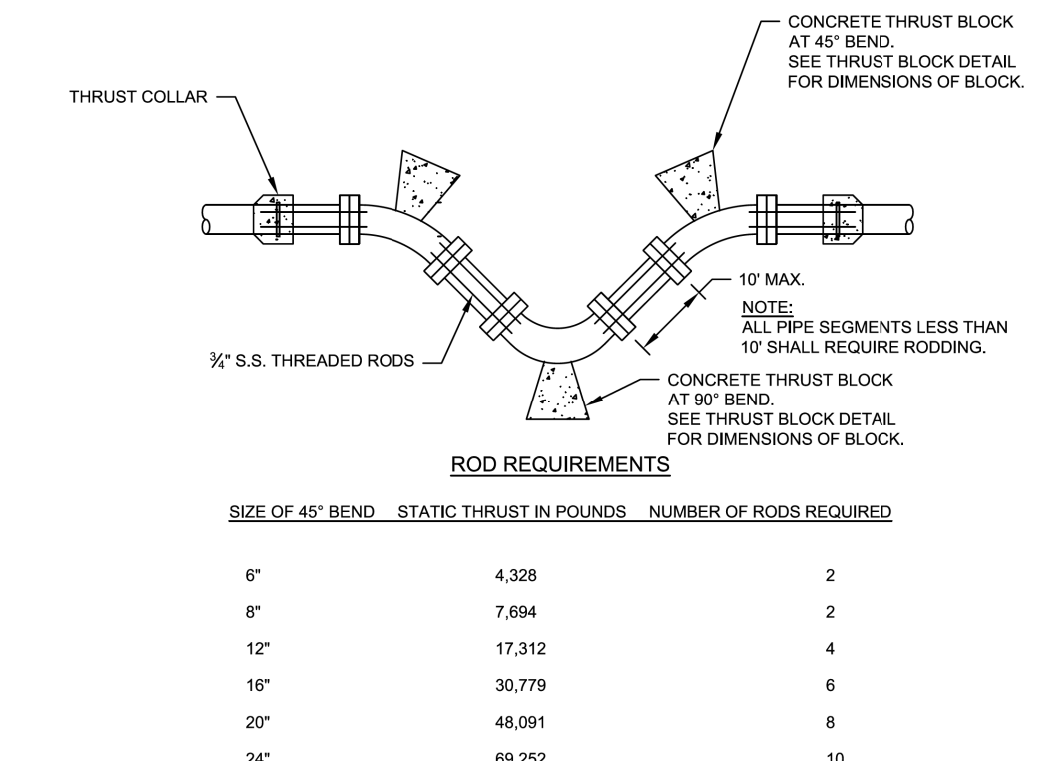

**VERTICAL BEND RODDING AND BLOCKING DETAIL**  
NOT TO SCALE

GENERAL NOTES:  
1. RODS AND NUTS SHALL BE OF TYPE 304 OR TYPE 316 STAINLESS STEEL.  
2. CONCRETE SHALL NOT CONTACT BOLTS OR ENDS OF MECHANICAL JOINT BENDS.

SIZE OF 45° BEND	STATIC THRUST IN POUNDS	NUMBER OF RODS REQUIRED
6"	4,328	2
8"	7,684	2
12"	17,312	4
16"	30,779	6
20"	48,091	8
24"	69,252	10

Drawn By:	Name	Date		<b>JOHNSTON COUNTY</b> Department of Public Utilities P.O. Box 2263 Smithfield, NC 27577	<b>WATER STANDARD DETAIL</b> Critical Bend Rodding and Blocking Details	PAGE <b>7</b>
Checked By:						
Approved By:						
Scale:						
Rev.	Description	Date	Int.			

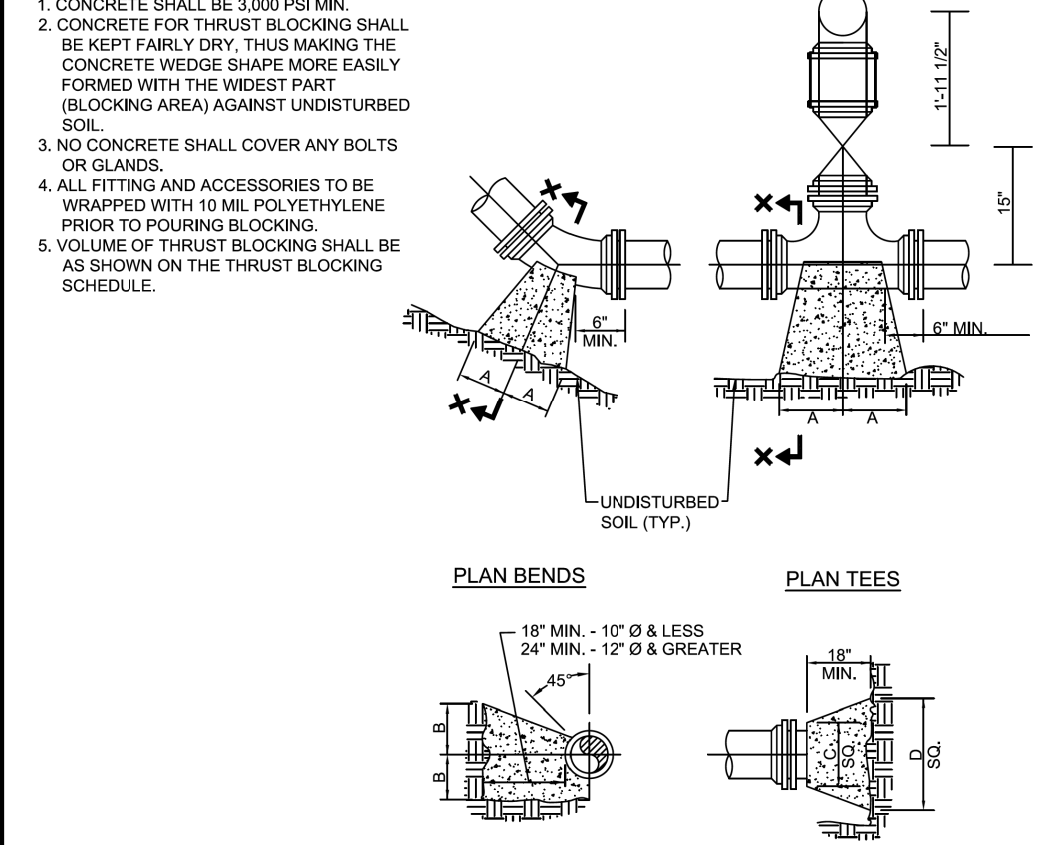

**THRUST BLOCK DETAIL**  
NOT TO SCALE

NOTE:  
1. CONCRETE SHALL BE 3,000 PSI MIN.  
2. CONCRETE FOR THRUST BLOCKING SHALL BE KEPT FAIRLY DRY. THIS MAKING THE CONCRETE WEDGE SHAPE MORE EASILY FORMED WITH THE WIDEST PART (BLOCKING AREA) AGAINST UNDISTURBED SOIL.  
3. NO CONCRETE SHALL COVER ANY BOLTS OR GLANDS.  
4. ALL FITTING AND ACCESSORIES TO BE WRAPPED WITH 10 MIL POLYETHYLENE PRIOR TO POURING BLOCKING.  
5. VOLUME OF THRUST BLOCKING SHALL BE AS SHOWN ON THE THRUST BLOCKING SCHEDULE.

PIPE SIZE	90° BEND				45° BEND				22 1/2° BEND				11 1/4° BEND				TEE				PLUG			
	A	B	C	D	A	B	C	D	A	B	C	D	A	B	C	D	A	B	C	D				
6"	12"	12"	12"	12"	12"	12"	12"	12"	12"	12"	12"	12"	12"	12"	12"	12"	12"	12"	12"	12"	12"	12"	12"	12"
8"	12"	12"	12"	12"	12"	12"	12"	12"	12"	12"	12"	12"	12"	12"	12"	12"	12"	12"	12"	12"	12"	12"	12"	12"
10"	12"	12"	12"	12"	12"	12"	12"	12"	12"	12"	12"	12"	12"	12"	12"	12"	12"	12"	12"	12"	12"	12"	12"	12"
12"	12"	12"	12"	12"	12"	12"	12"	12"	12"	12"	12"	12"	12"	12"	12"	12"	12"	12"	12"	12"	12"	12"	12"	12"
14"	12"	12"	12"	12"	12"	12"	12"	12"	12"	12"	12"	12"	12"	12"	12"	12"	12"	12"	12"	12"	12"	12"	12"	12"
16"	12"	12"	12"	12"	12"	12"	12"	12"	12"	12"	12"	12"	12"	12"	12"	12"	12"	12"	12"	12"	12"	12"	12"	12"
18"	12"	12"	12"	12"	12"	12"	12"	12"	12"	12"	12"	12"	12"	12"	12"	12"	12"	12"	12"	12"	12"	12"	12"	12"
20"	12"	12"	12"	12"	12"	12"	12"	12"	12"	12"	12"	12"	12"	12"	12"	12"	12"	12"	12"	12"	12"	12"	12"	12"
24"	12"	12"	12"	12"	12"	12"	12"	12"	12"	12"	12"	12"	12"	12"	12"	12"	12"	12"	12"	12"	12"	12"	12"	12"

Drawn By:	Name	Date		<b>JOHNSTON COUNTY</b> Department of Public Utilities P.O. Box 2263 Smithfield, NC 27577	<b>WATER STANDARD DETAIL</b> Thrust Block	PAGE <b>8</b>
Checked By:						
Approved By:						
Scale:						
Rev.	Description	Date	Int.			

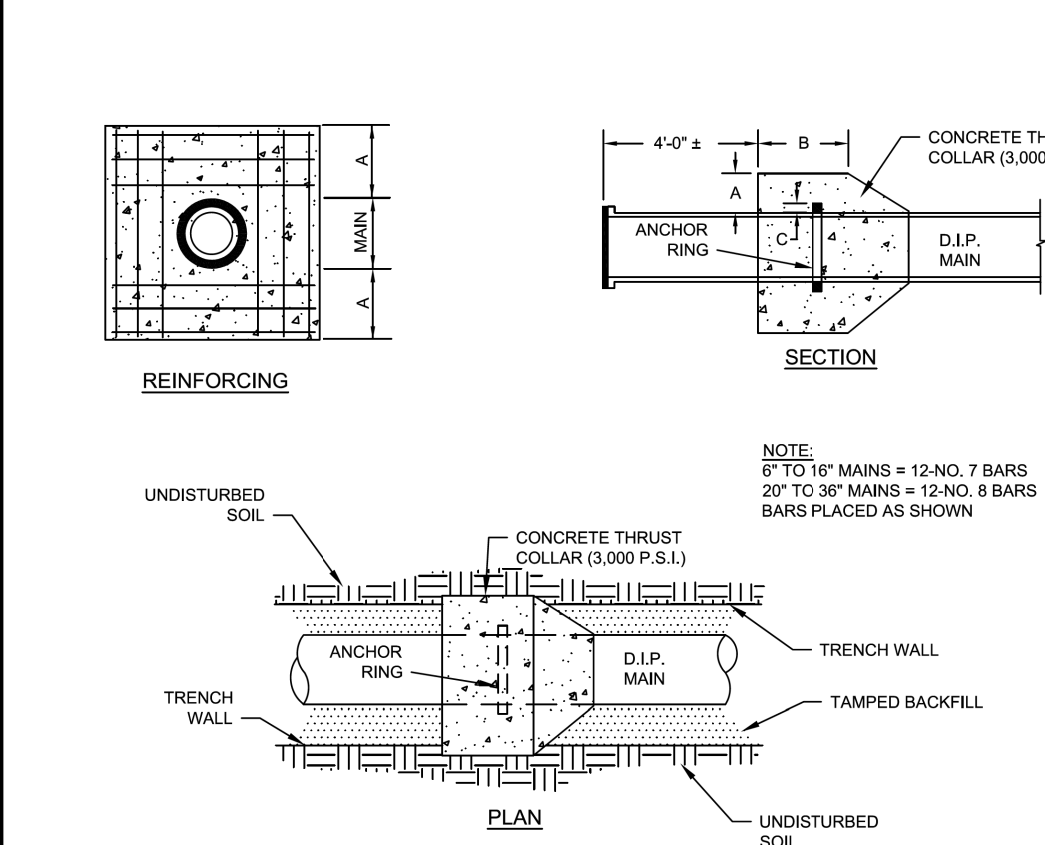

**THRUST COLLAR INSTALLATION**  
NOT TO SCALE

NOTE:  
6" TO 16" MAINS = 12-NO. 7 BARS  
20" TO 36" MAINS = 12-NO. 8 BARS  
BARS PLACED AS SHOWN.

PIPE DIAMETER	CONCRETE THRUST COLLAR			ANCHOR COLLAR	RINGS REQUIRED
	A	B	C		
6", 8", 12"	1-1/2"	1-1/2"	2"	ONE	
16"	1-1/2"	1-1/2"	2"	ONE	
20"	1-1/2"	1-1/2"	2"	ONE	
24"	1-1/2"	1-1/2"	3"	TWO	
30"	1-1/2"	1-1/2"	4"	TWO	
36"	1-1/2"	1-1/2"	4"	TWO	

Drawn By:	Name	Date		<b>JOHNSTON COUNTY</b> Department of Public Utilities P.O. Box 2263 Smithfield, NC 27577	<b>WATER STANDARD DETAIL</b> Thrust Collar Installation	PAGE <b>9</b>
Checked By:						
Approved By:						
Scale:						
Rev.	Description	Date	Int.			

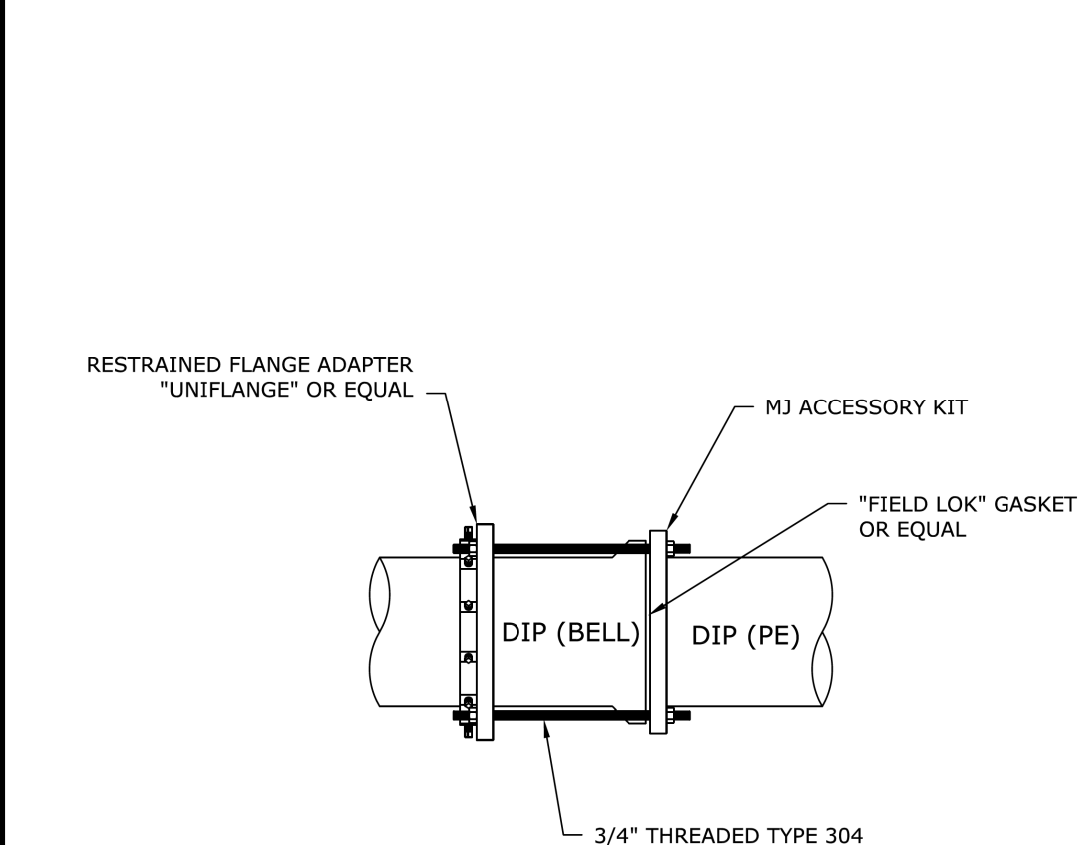

**HARNES RESTRAINT DETAIL**  
NOT TO SCALE

Drawn By:	Name	Date		<b>JOHNSTON COUNTY</b> Department of Public Utilities P.O. Box 2263 Smithfield, NC 27577	<b>WATER STANDARD DETAIL</b> Restraint Harness	PAGE <b>10</b>
Checked By:						
Approved By:						
Scale:						
Rev.	Description	Date	Int.			

5/14/99