

CLASS II (PARTIAL DEPTH) REPAIR

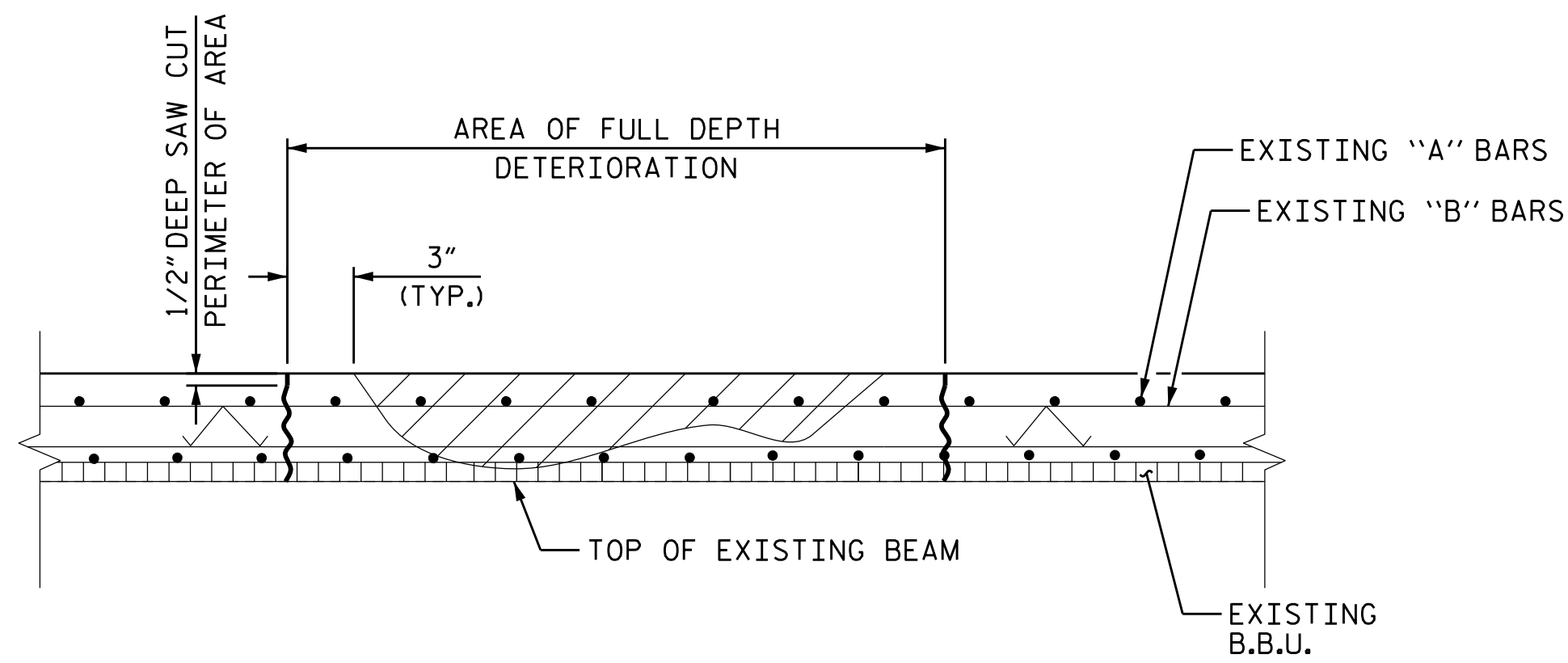

CLASS III (FULL DEPTH) REPAIR

NOTES

- FOR AREAS TO BE REPAIRED, SEE "PLAN OF SPAN" SHEETS.
- ALL DECK REPAIRS SHALL BE COMPLETED PRIOR TO PLACEMENT OF OVERLAY.
- FOR CLASS II AND CLASS III SURFACE PREPARATION, SEE "OVERLAY SURFACE PREPARATIONS" SPECIAL PROVISION.
- FOR CONCRETE FOR DECK REPAIR, SEE SPECIAL PROVISIONS.
- FOR SHOTCRETE REPAIR, SEE SPECIAL PROVISIONS.
- THE CONTRACTOR SHALL SUBMIT WORKING DRAWINGS TO THE ENGINEER FOR APPROVAL PRIOR TO STARTING WORK FOR TEMPORARY FORMWORK. FOR SUBMITTALS OF WORKING DRAWINGS, SEE SPECIAL PROVISIONS.
- UPON REMOVAL OF TEMPORARY FORMWORK, ALL VOIDS AND HONEYCOMBS ON THE UNDERSIDE OF DECK SURFACE SHALL BE FILLED WITH THE SAME MATERIAL AS USED FOR THE PATCH, AND FINISHED TO CONFORM TO THE SURROUNDING CONCRETE SURFACE.
- NO FORMWORK SHALL BE LEFT IN PLACE.

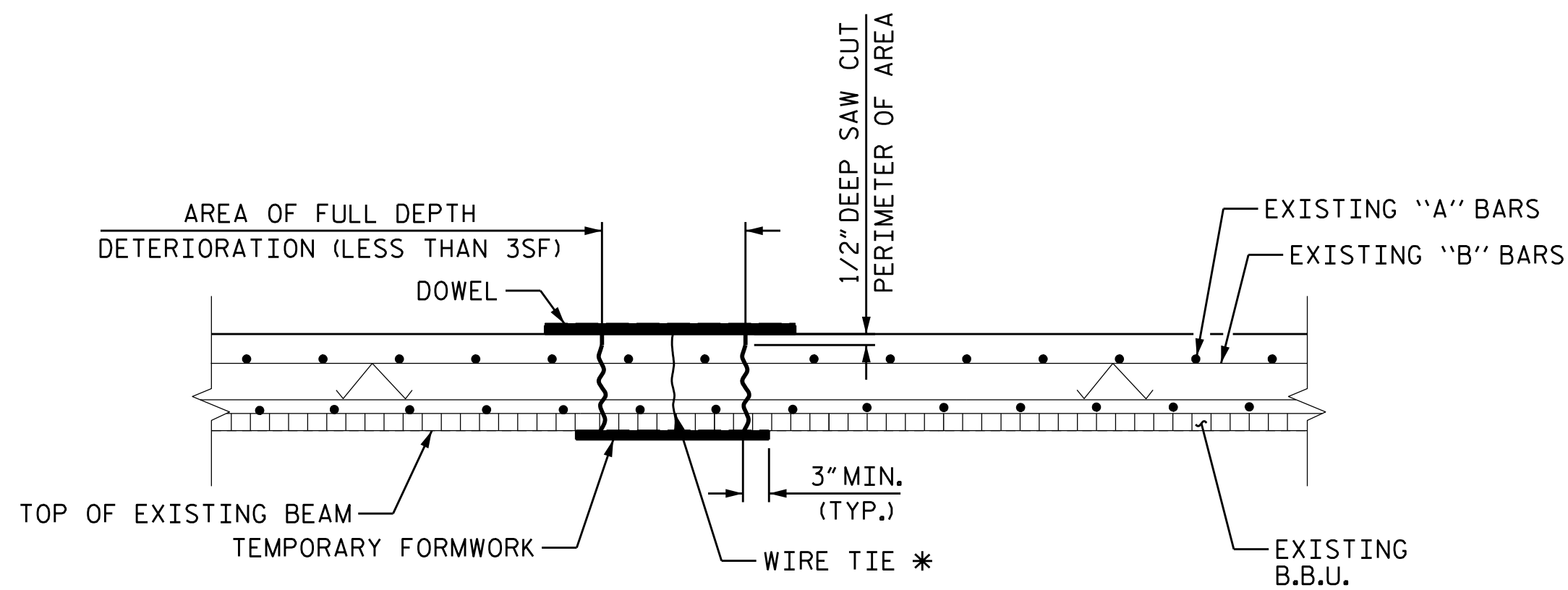

FULL DEPTH REPAIR WITH TEMPORARY FORMWORK

(FOR AREAS OF DETERIORATION EQUAL TO OR LESS THAN 3SF)

* WIRE TIE TO BE KNOTTED BELOW TEMPORARY FORMWORK AND ATTACHED TO DOWEL THAT IS WIDER THAN FORMED FULL DEPTH HOLE. ROTATE DOWEL TO TIGHTEN FORMWORK AGAINST BOTTOM OF DECK.

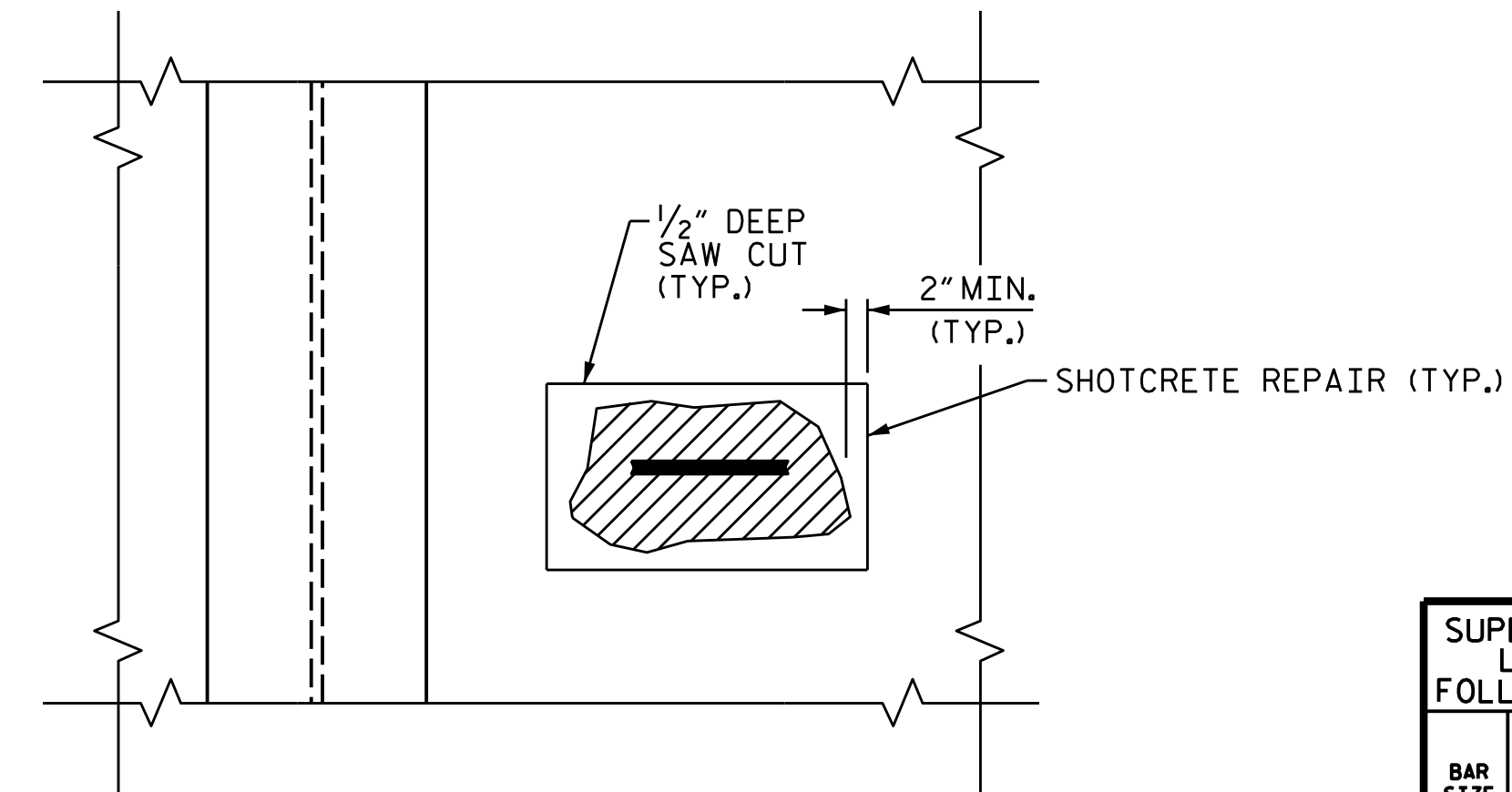

SECTION D-D

BAR SIZE	SUPERSTRUCTURE REINFORCING STEEL LENGTHS ARE BASED ON THE FOLLOWING MINIMUM SPLICE LENGTHS				
	SUPERSTRUCTURE EXCEPT APPROACH SLABS, PARAPET, AND BARRIER RAIL		APPROACH SLABS		PARAPET AND BARRIER RAIL
	EPOXY COATED	UNCOATED	EPOXY COATED	UNCOATED	
#4	1'-11"	1'-7"	1'-11"	1'-7"	2'-6"
#5	2'-5"	2'-0"	2'-5"	2'-0"	3'-1"
#6	2'-10"	2'-5"	3'-7"	2'-5"	3'-8"
#7	4'-2"	2'-9"			
#8	4'-9"	3'-2"			

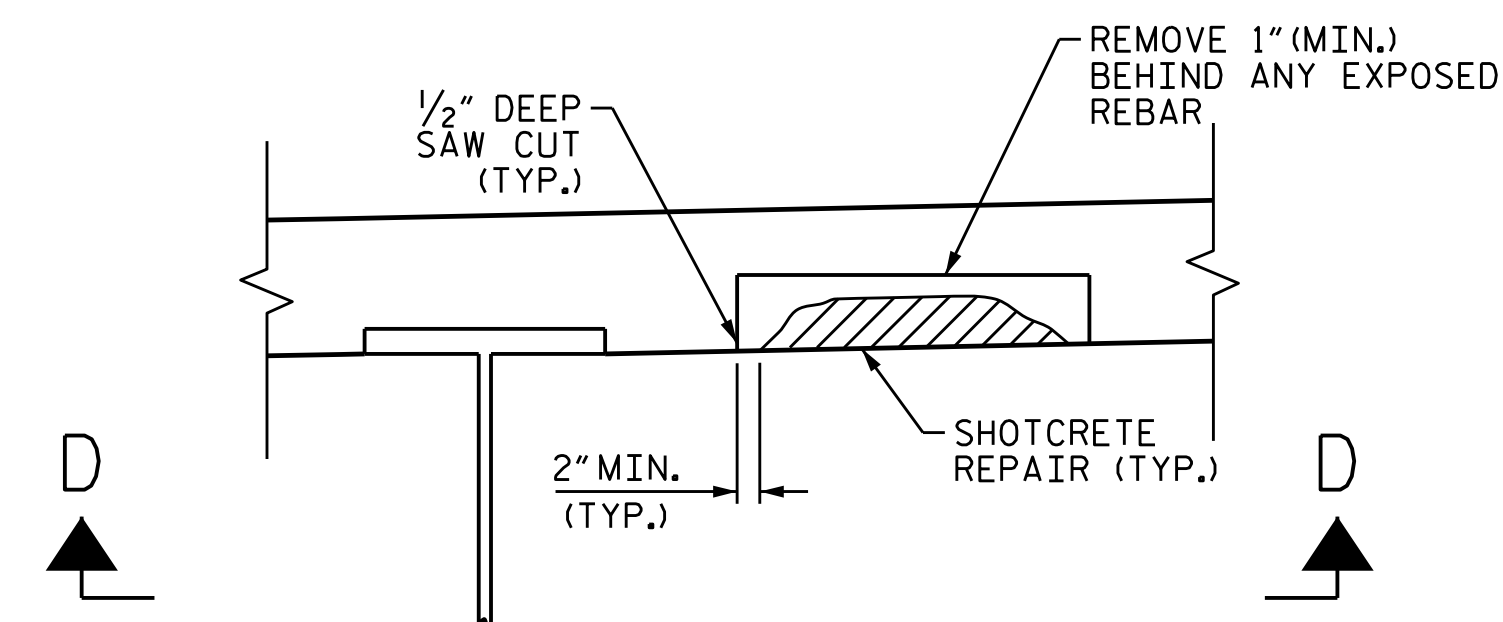

TYPICAL SECTION

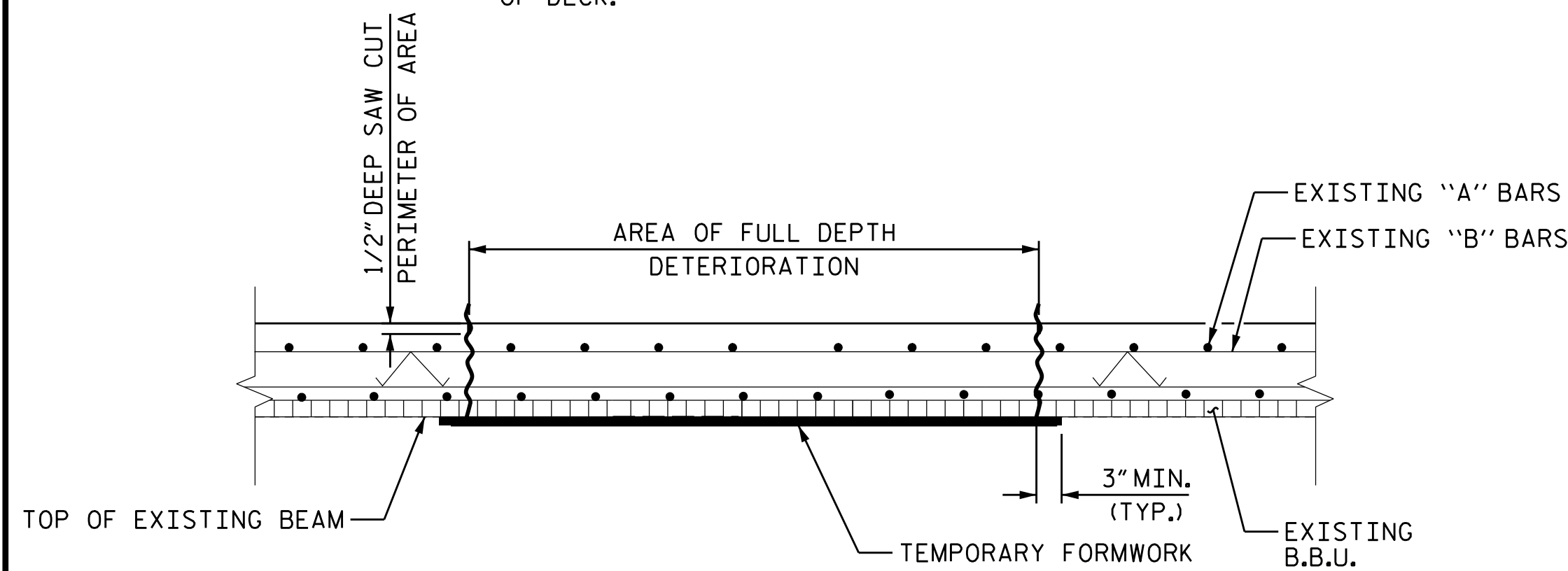

FULL DEPTH REPAIR WITH TEMPORARY FORMWORK

(FOR AREAS OF DETERIORATION GREATER THAN 3SF)

UNDERSIDE OF DECK REPAIR

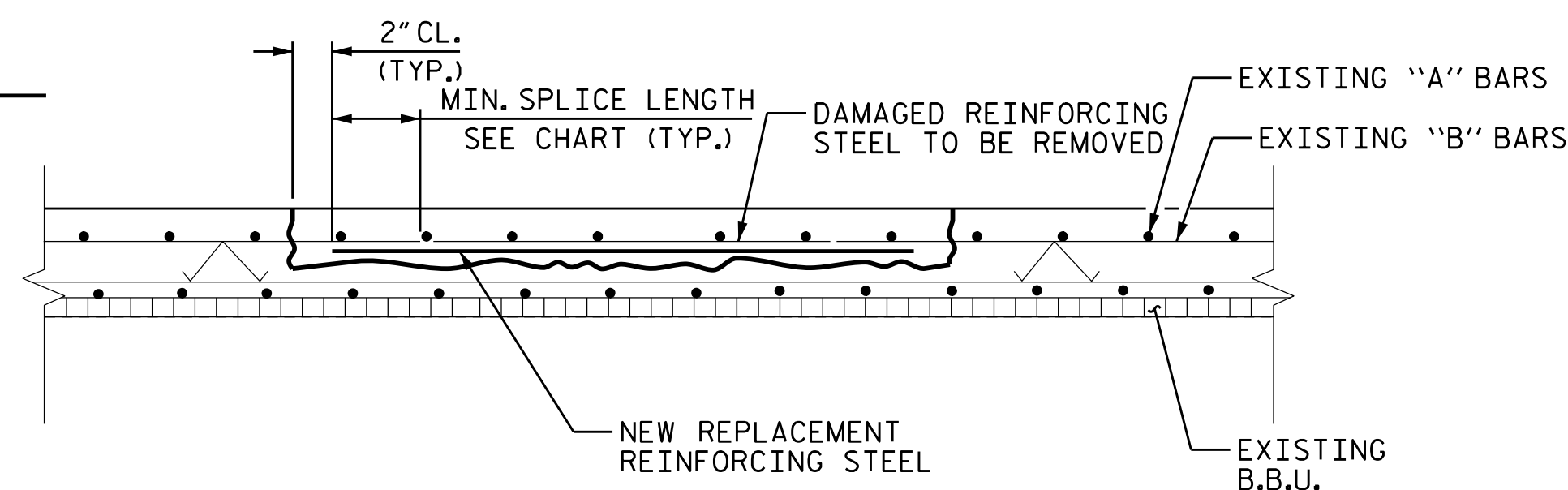

REINFORCING STEEL REPAIR

PROJECT NO. 15BPR.47
NASH COUNTY
 BRIDGE NO. 630123

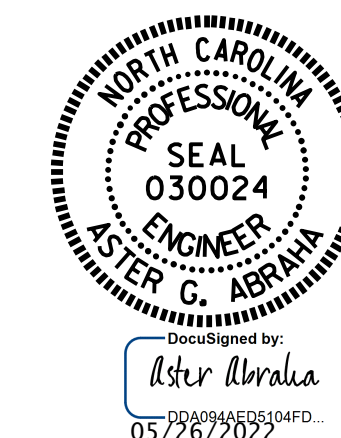

STATE OF NORTH CAROLINA
 DEPARTMENT OF TRANSPORTATION
 RALEIGH
 STANDARD
 DECK REPAIR DETAILS

ASSEMBLED BY :	S. T. S./A.Y.G.	DATE :	01/2022
CHECKED BY :	S. WANCE	DATE :	03/2022
DRAWN BY :	NAP 9/18		
CHECKED BY :			

DOCUMENT NOT CONSIDERED
 FINAL UNLESS ALL
 SIGNATURES COMPLETED

REVISIONS						SHEET NO.
NO.	BY:	DATE:	NO.	BY:	DATE:	
1			3			S4-15
2			4			TOTAL SHEETS 18