

REPAIR QUANTITY TABLE



UNDERSIDE OF DECK REPAIRS - SPAN D	QUANTITIES			
	ESTIMATE		ACTUAL	
SHOTCRETE REPAIRS	AREA SF	VOLUME CF	AREA SF	VOLUME CF
UNDERSIDE OF DECK	0.0	0.0		
CONCRETE BENT DIAPHRAGM	6.4	2.2		
OVERHANG	4.8	1.6		
CONCRETE REPAIRS	AREA SF	VOLUME CF	AREA SF	VOLUME CF
UNDERSIDE OF DECK	0.0	0.0		
CONCRETE BENT DIAPHRAGM	0.0	0.0		
OVERHANG	0.0	0.0		

VALUES IN CHART REPRESENT ESTIMATED REPAIR TOTALS AFTER REMOVAL OF UNSOUND CONCRETE, MIN. OF 1" BEHIND REBAR AND MIN. 2" CL TO SAWCUT. SEE REPAIR DETAILS.

NOTES:

THE LOCATIONS AND DIMENSIONS OF THE AREAS FOR REPAIR ARE BASED ON THE BEST INFORMATION AVAILABLE. THE CONTRACTOR, IN CONJUNCTION WITH THE ENGINEER, SHALL VERIFY THE LOCATION AND EXTENT OF REPAIR AREAS PRIOR TO STEEL FABRICATION. IF ADDITIONAL REPAIRS NOT SHOWN ON THE DRAWINGS ARE DEEMED NECESSARY BY THE ENGINEER, THE ENGINEER WILL NOTE ON THE DRAWINGS THE APPROXIMATE LOCATION AND DESCRIPTION OF THE REPAIRS AND ENTER THE ACTUAL QUANTITIES INTO THE REPAIR QUANTITY TABLE.

FOR ADDITIONAL NOTES, SEE SHEET 1 OF 6.

-  - CONCRETE REPAIR AREA
-  - SHOTCRETE REPAIR AREA
- (B#) BEAM NUMBER
- (W) WEB PLATING REPAIR
- (S) STIFFENER REPAIR
- (F) BOTTOM FLANGE PLATING REPAIR
- (BW) BOLTED WEB PLATE REPAIR
- (BF) BOLTED FLANGE PLATE REPAIR

STEEL REPAIR LOCATIONS

REPAIR	SPAN	BEAM	LOCATION	DIM. "A"	DIM. "B"	DIM. "C"	DIM. "D"
W	D	5	BENT 3	5"	39"	-	-
F	D	5	BENT 3	5 1/4"	39"	-	-
S	D	5	BENT 3	5"	-	-	-
W	D	8	BENT 3	5"	72"	-	-
F	D	8	BENT 3	5 1/4"	39"	-	-
S	D	8	BENT 3	5"	-	-	-
W	D	1	BENT 4	5"	80"	-	-
F	D	1	BENT 4	5 1/4"	36"	-	-
S	D	1	BENT 4	5"	-	-	-
W	D	6	BENT 4	34"	9"	-	-
F	D	8	BENT 4	5 1/2"	16"	-	-
S	D	8	BENT 4	3"	-	-	-

(SEE SHEETS S1-27 AND S1-28 FOR BEAM REPAIR DETAILS AND DIMENSIONS.)

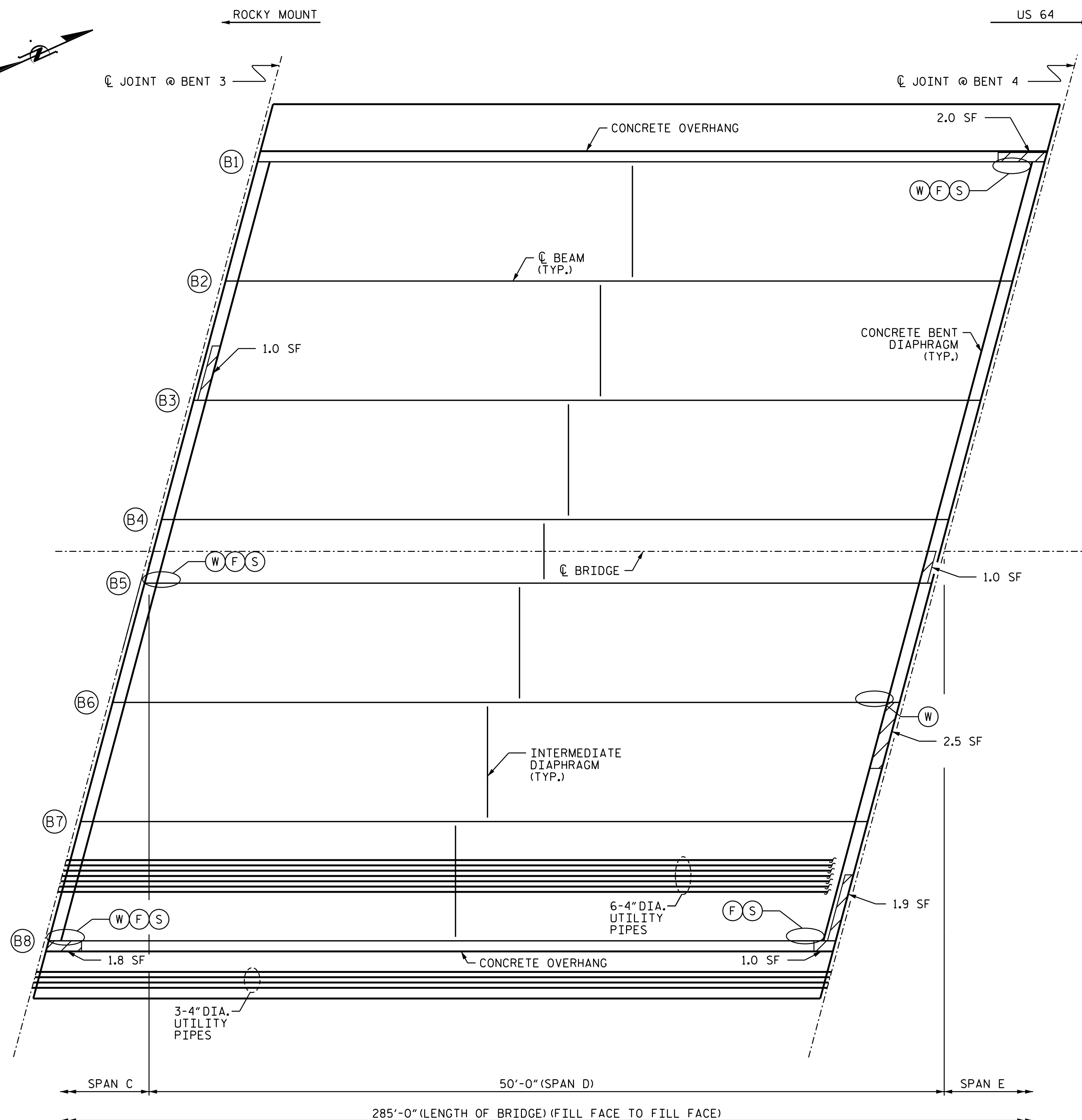

SPAN D (UNDERSIDE)

BEAM REPAIR QUANTITY TABLE									
BOLTED STEEL PLATES		STEEL PLATES		STIFFENER		STEEL DIAPHRAGM		BEAM END CUT-OUT	
LBS.		LBS.		LBS.		LBS.		LBS.	
ESTIMATE	ACTUAL	ESTIMATE	ACTUAL	ESTIMATE	ACTUAL	ESTIMATE	ACTUAL	ESTIMATE	ACTUAL
0		534.1		33.9		0		0	

DRAWN BY : A. Y. GODFREY DATE : 01/2022
 CHECKED BY : G. AYES DATE : 02/2022

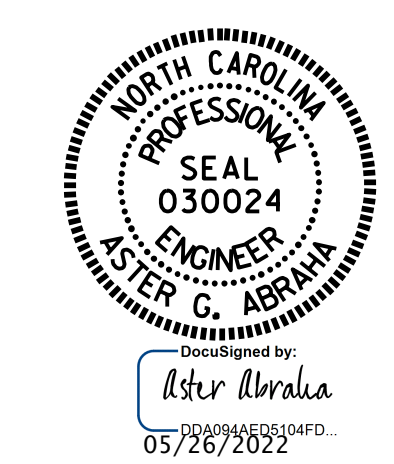

PROJECT NO. 15BPR.47
 EDGEcombe COUNTY
 BRIDGE NO. 320051
 SHEET 4 OF 6

STATE OF NORTH CAROLINA
 DEPARTMENT OF TRANSPORTATION
 RALEIGH

UNDERSIDE DECK REPAIRS SPAN D

REVISIONS						SHEET NO.
NO.	BY:	DATE:	NO.	BY:	DATE:	S1-13
1			3			TOTAL SHEETS
2			4			31

DOCUMENT NOT CONSIDERED FINAL UNLESS ALL SIGNATURES COMPLETED