

**This electronic collection of documents is provided
for the convenience of the user
and is Not a Certified Document –**

**The documents contained herein were originally issued
and sealed by the individuals whose names and license
numbers appear on each page, on the dates appearing
with their signature on that page.**

**This file or an individual page
shall not be considered a certified document.**

Brunswick County 1 - 6

PROJECT REFERENCE NO. 2022CPT.03.07.20101, ETC.	SHEET NO. 1
--	----------------

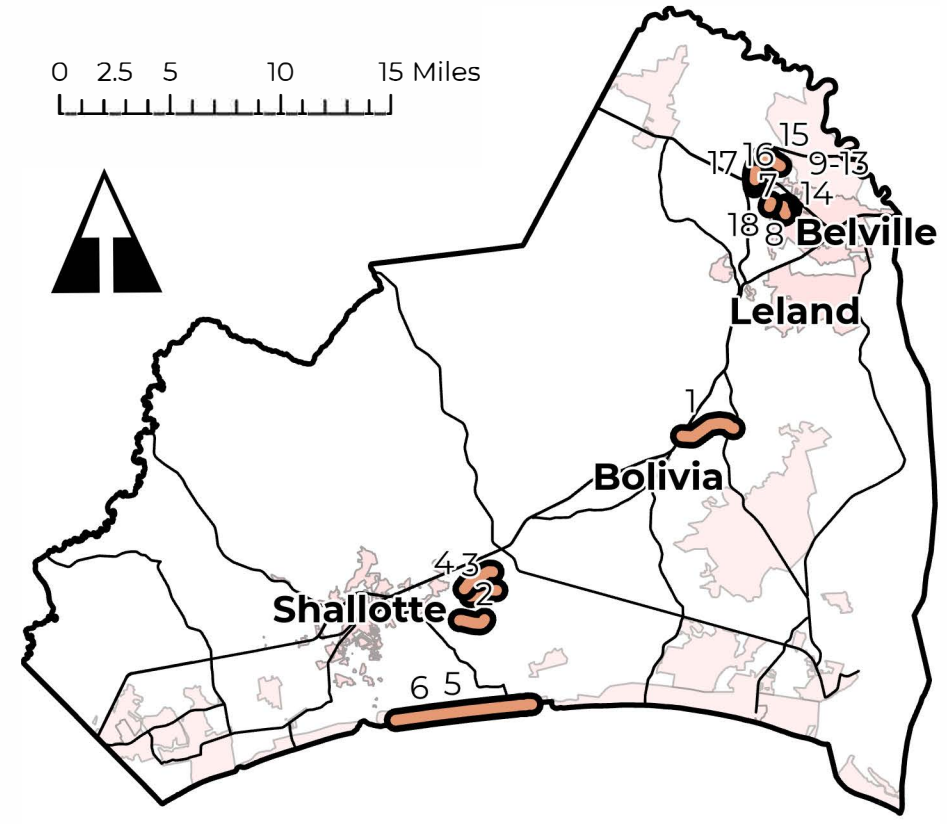
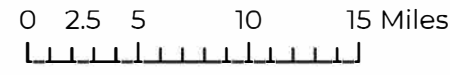

Legend

- Bridge
- State Maintained Road
- - - Municipality Road
- ▬ Road Section

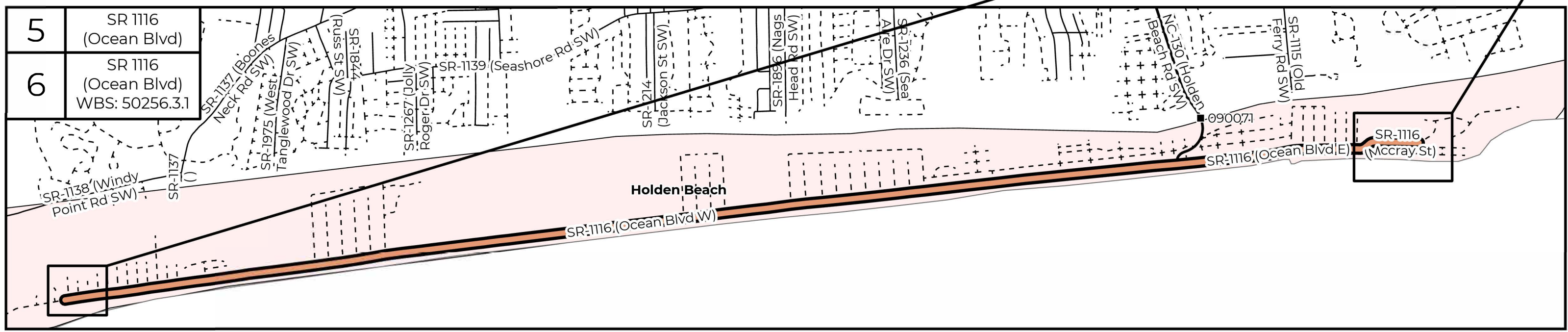
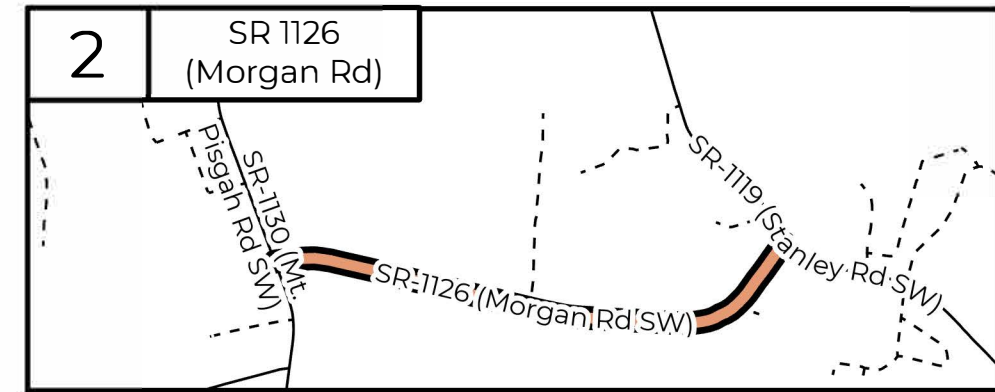
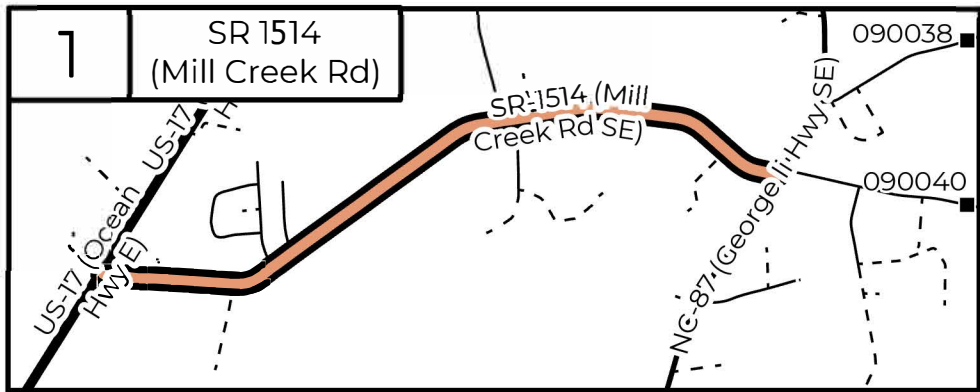
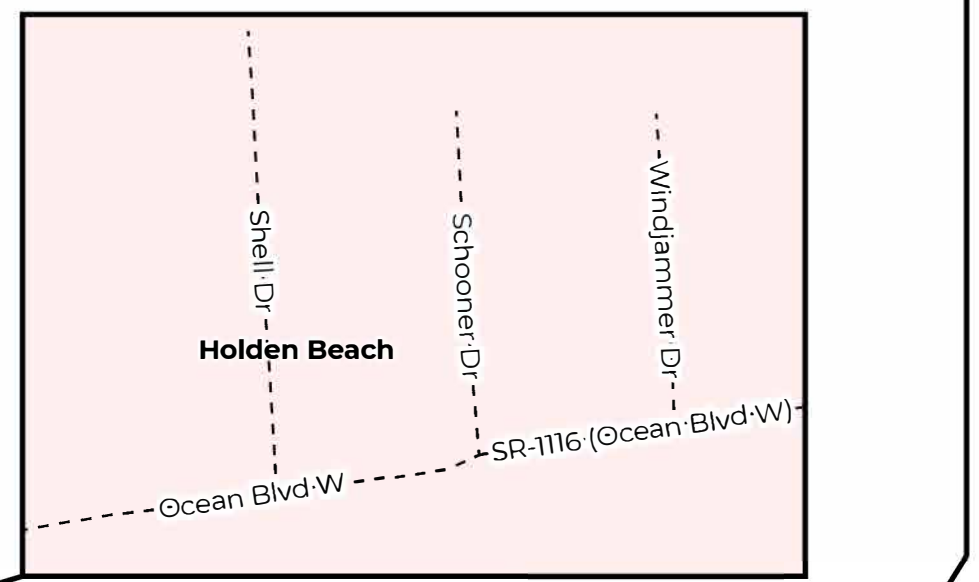
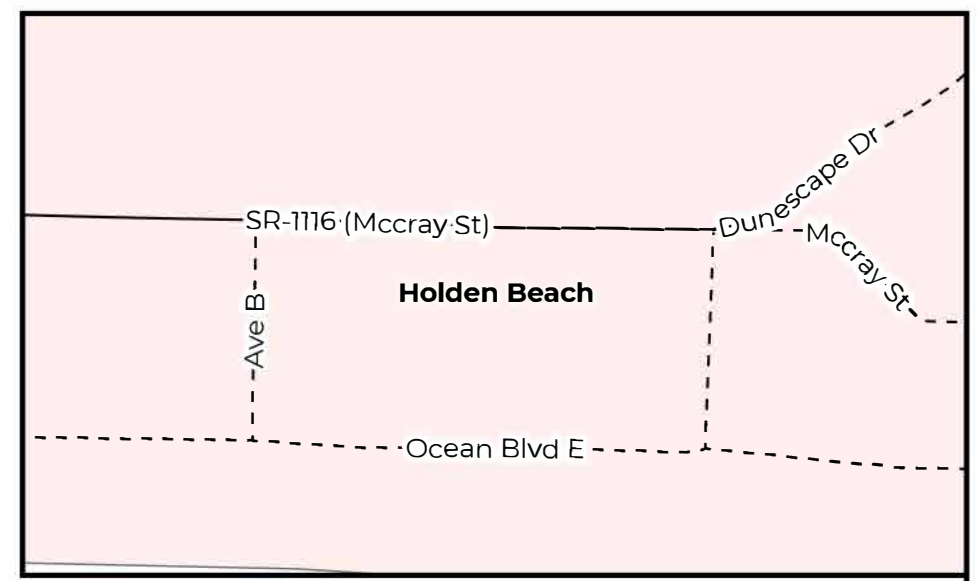
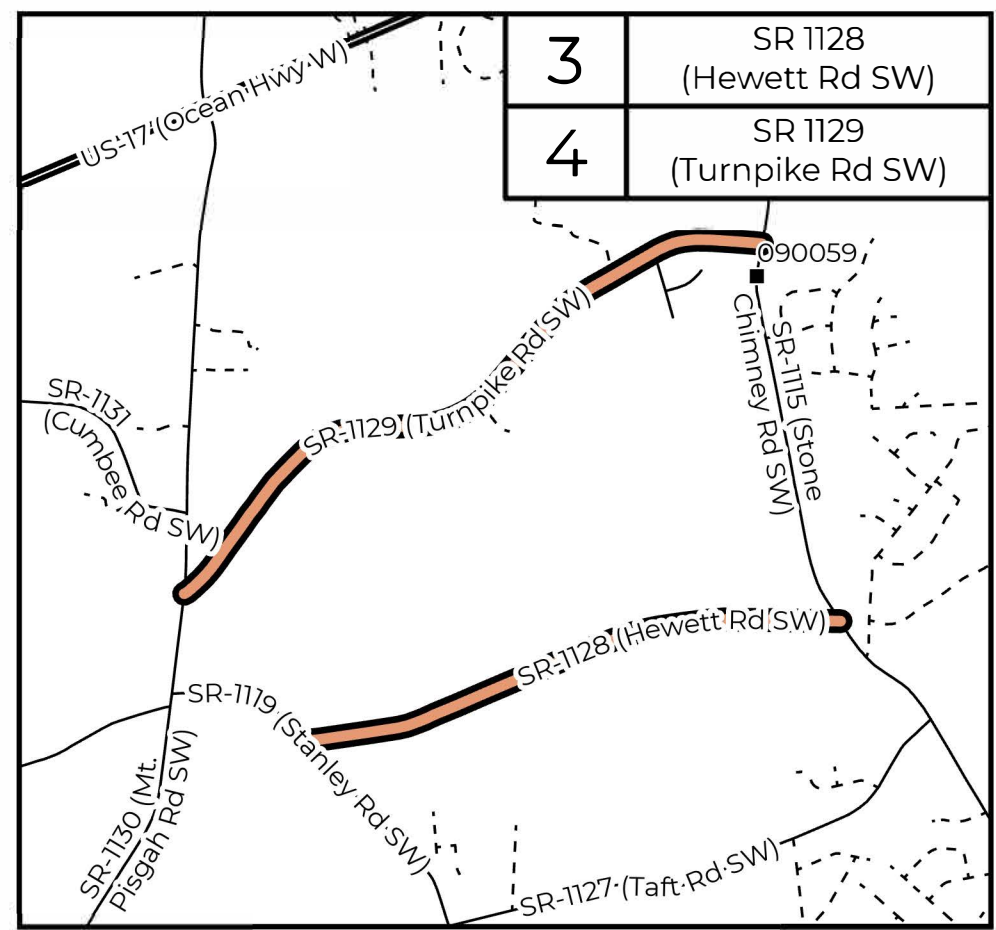

Brunswick County 7 - 18

PROJECT REFERENCE NO. 2022CPT.03.07.20101, ETC.	SHEET NO. 2
--	----------------

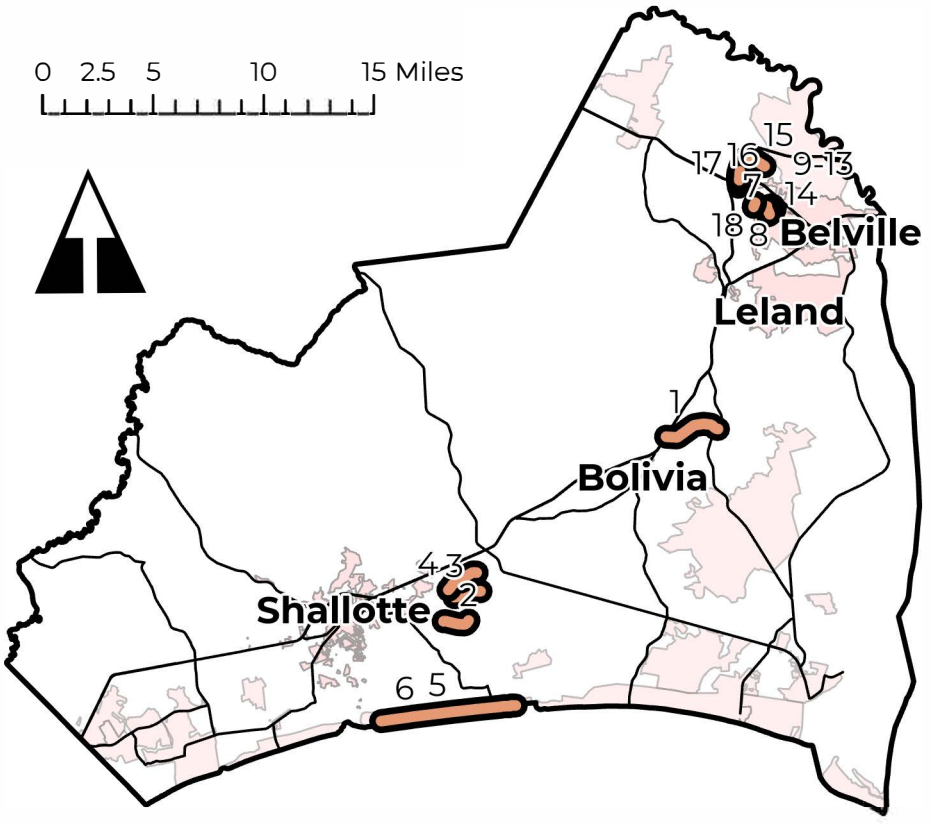
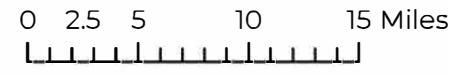

Legend

- Bridge
- State Maintained Road
- - - Municipality Road
- ▬ Road Section

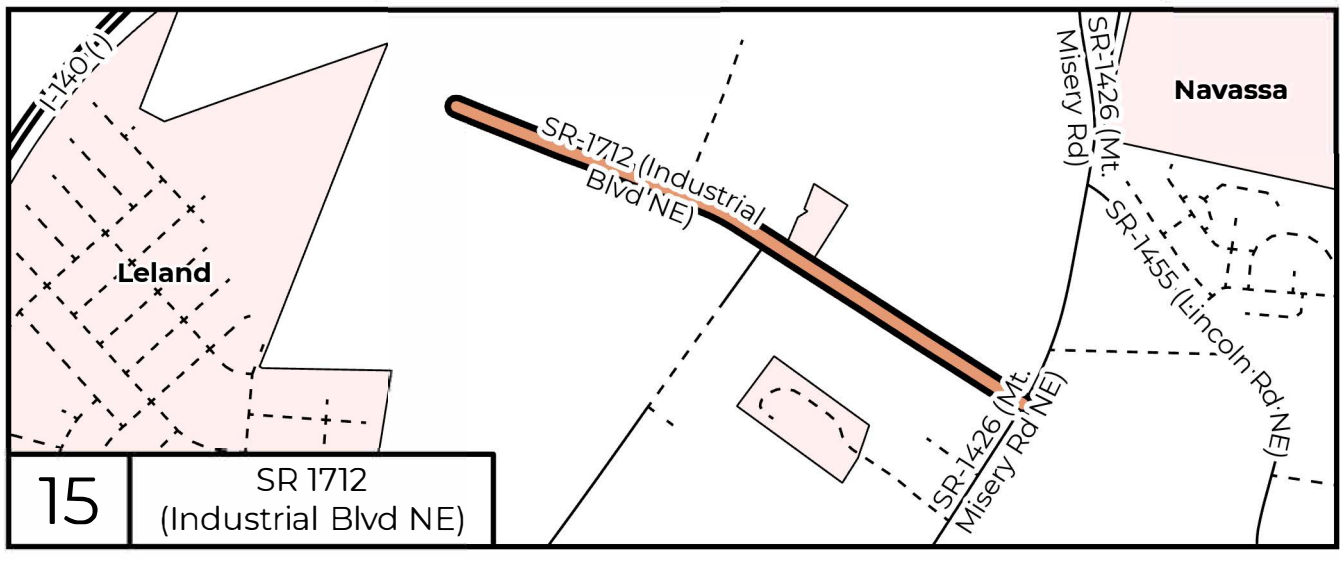

15	SR 1712 (Industrial Blvd NE)
----	---------------------------------

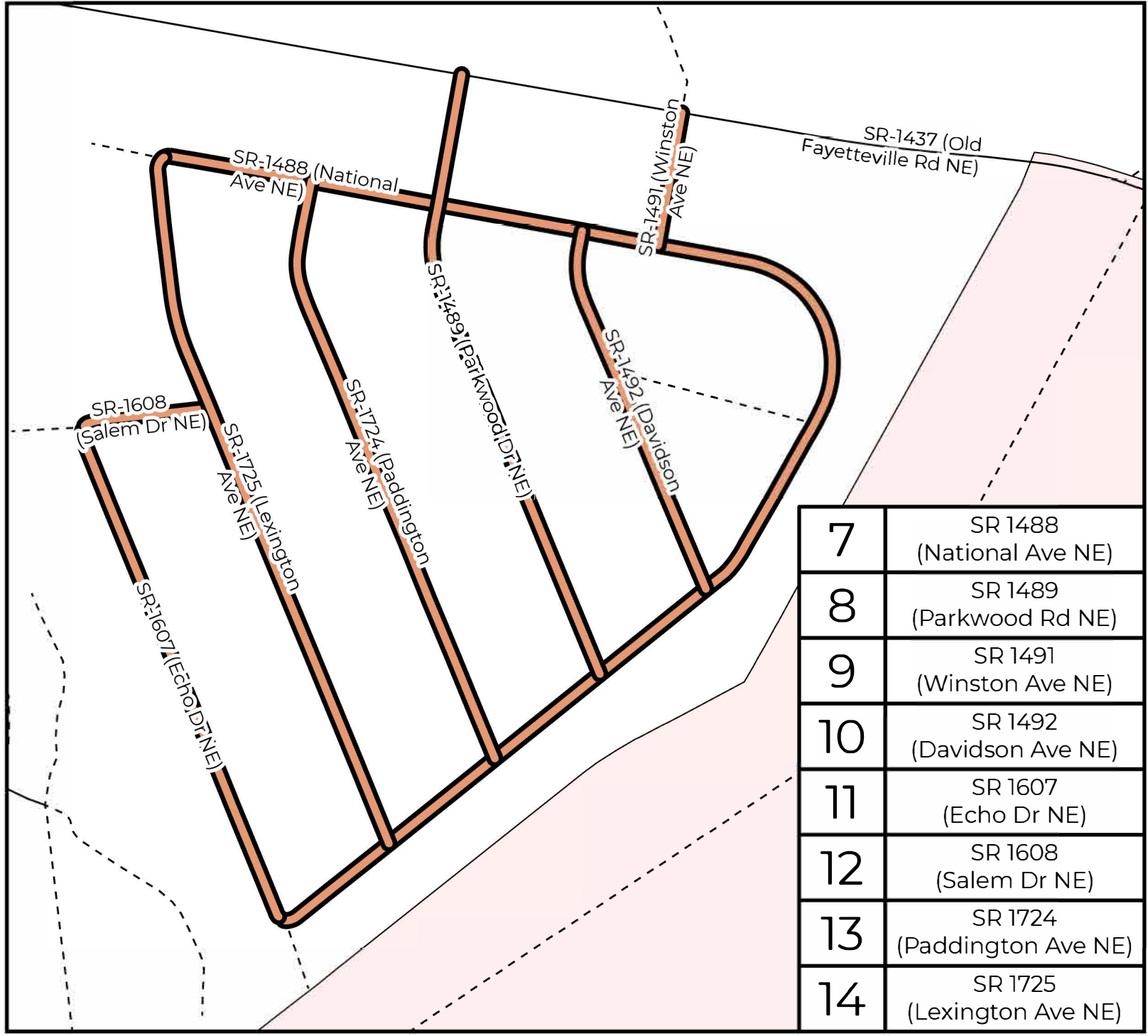

7	SR 1488 (National Ave NE)
8	SR 1489 (Parkwood Rd NE)
9	SR 1491 (Winston Ave NE)
10	SR 1492 (Davidson Ave NE)
11	SR 1607 (Echo Dr NE)
12	SR 1608 (Salem Dr NE)
13	SR 1724 (Paddington Ave NE)
14	SR 1725 (Lexington Ave NE)

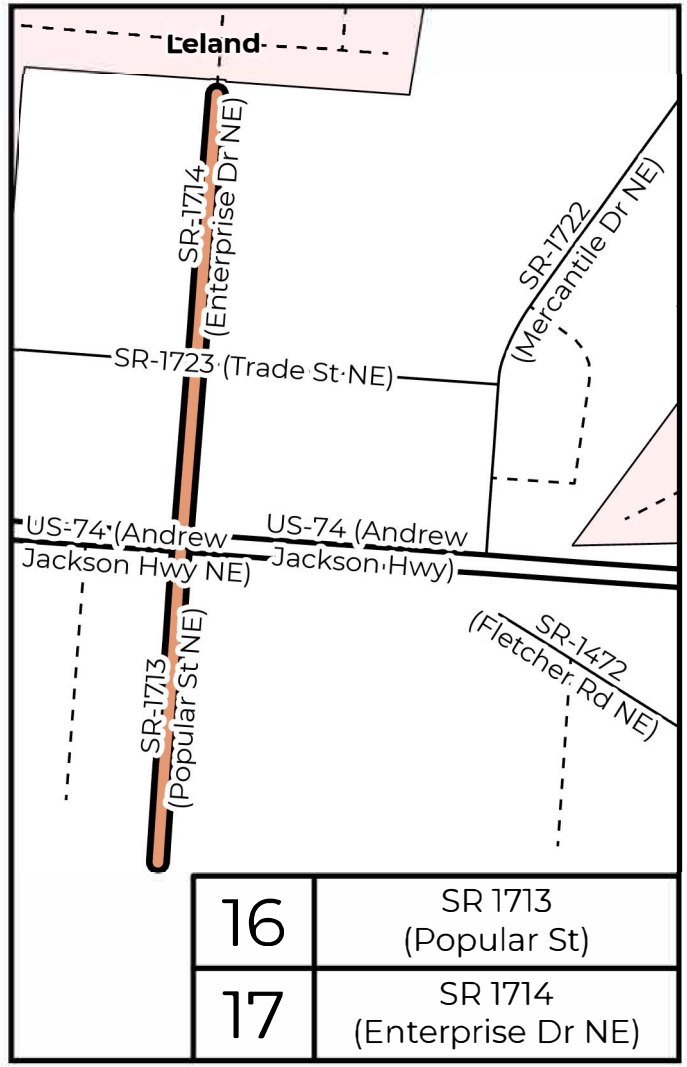

16	SR 1713 (Popular St)
17	SR 1714 (Enterprise Dr NE)

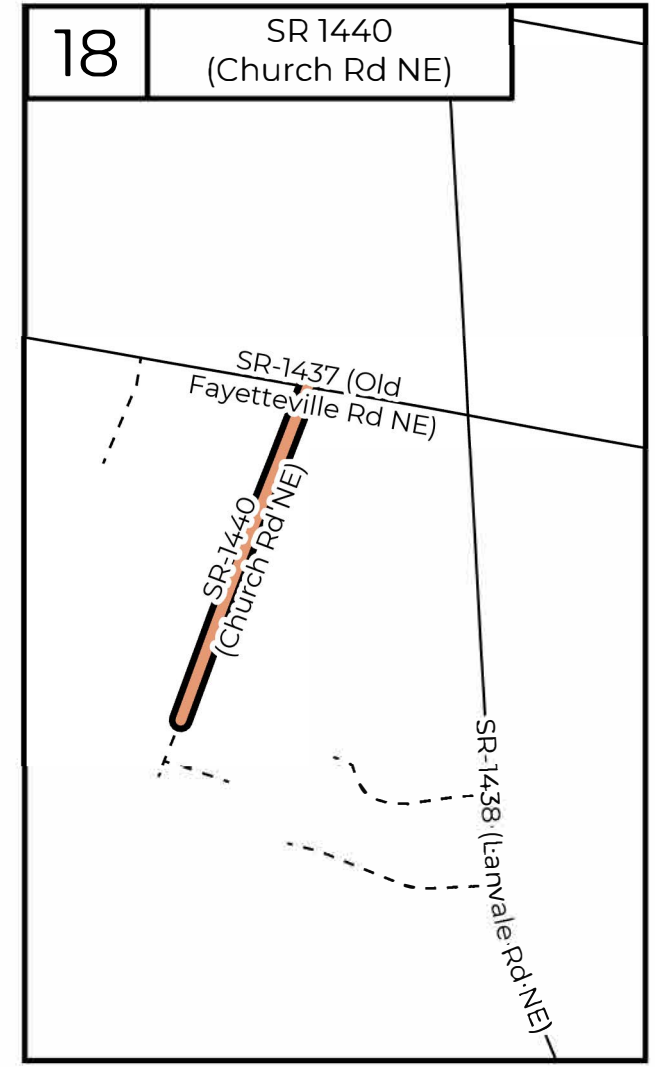

18	SR 1440 (Church Rd NE)
----	---------------------------

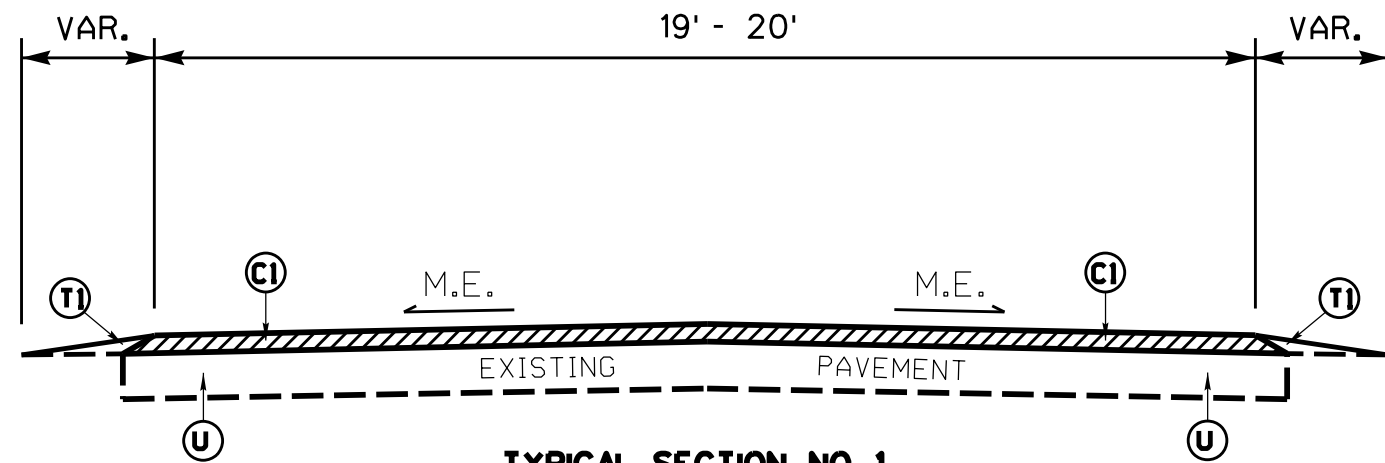

TYPICAL SECTION NO. 1

PAVEMENT SCHEDULE	
C1	PROP. APPROX. 1½" DEPTH ASPHALT CONCRETE SURFACE COURSE, TYPE S9.5B, AT AN AVERAGE RATE OF 165 LBS. PER SQ.YD.
C2	PROP. APPROX. 1" DEPTH ASPHALT CONCRETE SURFACE COURSE, TYPE S4.75A, AT AN AVERAGE RATE OF 110.0 LBS. PER SQ.YD.
T1	EARTH MATERIAL (SHOULDER RECONSTRUCTION)
U	EXISTING PAVEMENT

PAVEMENT EDGE SLOPES ARE 1:1, EXCEPT FINAL SURFACE COURSE. SEE SHOULDER WEDGE DETAIL.

NOTES: SHOULDER WORK ON MAP NO. 1 - 4 AS NEEDED, TO BE DETERMINED BY ENGINEER.

MAP NO. 1
SR 1514 (MILL CREEK RD.)
MP 0.05 - MP 2.60

MAP NO. 2
SR 1126 (MORGAN RD.)
MP 0.01 - MP 1.22

MAP NO. 3
SR 1128 (HEWETT RD.)
MP 0.00 - MP 1.24

MAP NO. 4
SR 1129 (TURNPIKE RD.)
MP 0.01 - MP 1.59

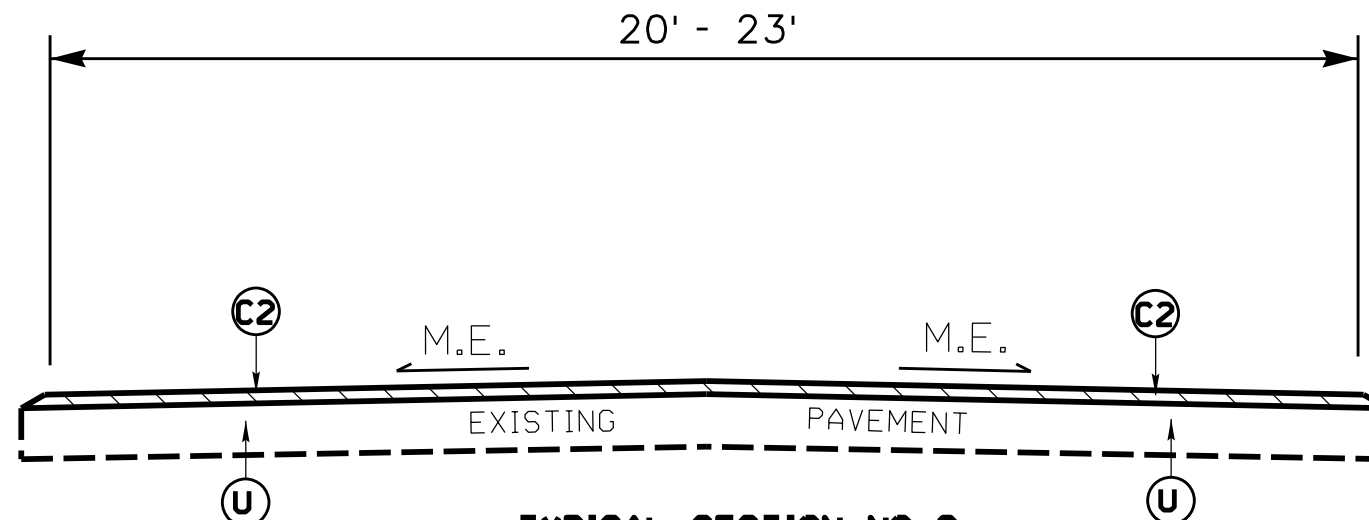

TYPICAL SECTION NO. 2

MAP NO. 7
SR 1488 (NATIONAL AVE. NE)
MP 0.00 - MP 0.81

MAP NO. 8
SR 1489 (PARKWOOD DR. NE)
MP 0.01 - MP 0.32

MAP NO. 9
SR 1491 (WINSTON AVE. NE)
MP 0.00 - MP 0.07

MAP NO. 10
SR 1492 (DAVIDSON AVE. NE)
MP 0.01 - MP 0.20

MAP NO. 11
SR 1607 (ECHO DR. NE)
MP 0.00 - MP 0.28

MAP NO. 12
SR 1608 (SALEM DR. NE)
MP 0.00 - MP 0.07

MAP NO. 13
SR 1724 (PADDINGTON AVE. NE)
MP 0.00 - MP 0.33

MAP NO. 14
SR 1725 (LEXINGTON AVE. NE)
MP 0.00 - MP 0.39

MAP NO. 15
SR 1712 (INDUSTRIAL BLVD. NE)
MP 0.00 - MP 0.39

MAP NO. 16
SR 1713 (POPULAR ST. NE)
MP 0.00 - MP 0.28

MAP NO. 17
SR 1714 (POPULAR ST. NE/ ENTERPRISE DR. NE)
MP 0.00 - MP 0.39

MAP NO. 18
SR 1440 (CHURCH RD. NE)
MP 0.00 - MP 0.21

REVISIONS

8/17/99
SYSTEMS DESIGN
NAME

STATE OF
NORTH CAROLINA
DEPT. OF TRANSPORTATION
DIVISION OF HIGHWAYS
RALEIGH, N.C.

ENGLISH DETAIL DRAWING FOR
MANHOLE AND VALVE BOX ADJUSTMENTS

SHEET 1 OF 1
840D55

GENERAL NOTES:

1. USE RAPID SET GROUT, MORTAR, OR CONCRETE THAT WILL TAKE FULL SET AND BECOME LOAD BEARING WITHIN SIXTY MINUTES OF PLACEMENT WITH A MINIMUM COMPRESSIVE STRENGTH OF 4000 PSI.
2. REMOVE ALL FAULTY EXISTING BRICKWORK AND REPLACE WITH NEW BRICK MASONRY.
3. SHEER CUT EXCAVATION FOR THE ADJUSTMENT ON ALL SIDES.
4. FILL AREA BELOW 8" DEPTH WITH 78M OR NO. 57 CLEAN STONE.
5. MIX MORTAR TO NCDOT SPECIFICATIONS.
6. MORTAR JOINTS $\frac{1}{2}$ " \pm $\frac{1}{8}$ "
7. CONSTRUCT AN ASPHALT RAMP IN ACCORDANCE WITH SECTION 858-3 OF THE 2018 STANDARD SPECIFICATIONS.

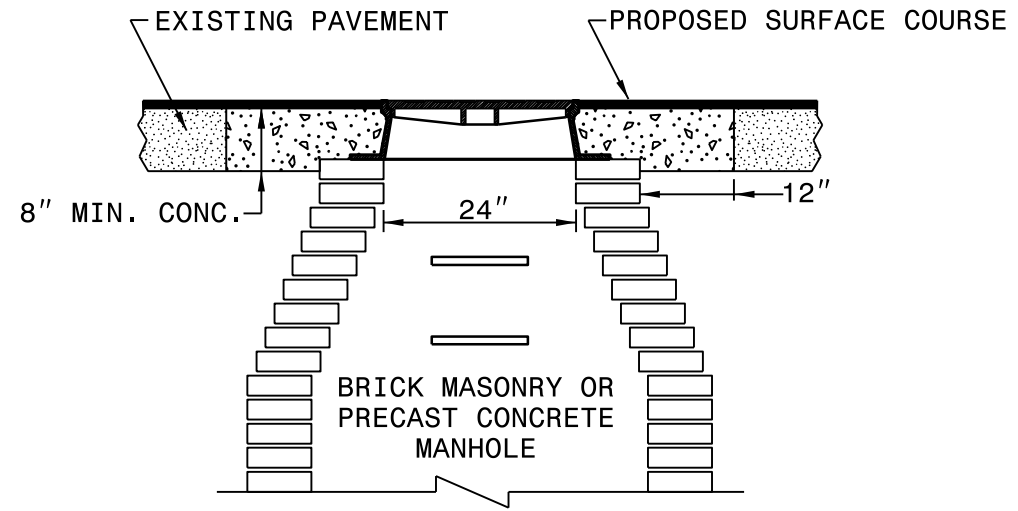

MANHOLE CONCRETE ENCASEMENT

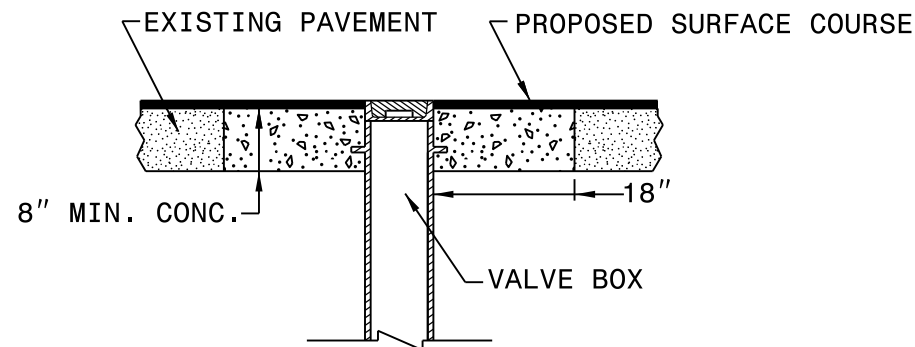

VALVE BOX CONCRETE ENCASEMENT

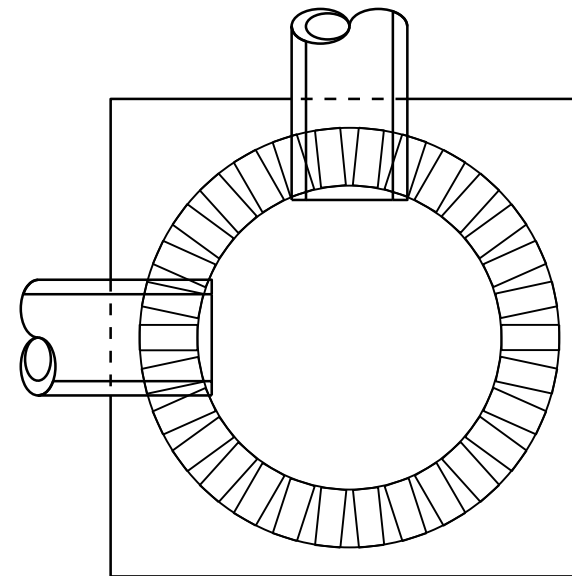

ELEVATION VIEW

PLACE BRICK ACCORDING TO ELEVATION VIEW

ENGLISH DETAIL DRAWING FOR

MANHOLE AND VALVE BOX ADJUSTMENTS

SHEET 1 OF 1
840D55

STATE OF
NORTH CAROLINA
DEPT. OF TRANSPORTATION
DIVISION OF HIGHWAYS
RALEIGH, N.C.

REVISIONS

28-NOV-2017 10:49
S:\Division Resurfacing\z Design Standards & Specifications\Drawings\Roadway\Roadway\840D55.dwg
8/17/99

- NOTES:
- 1) DETAIL DOES NOT APPLY TO OGAFC AND ULTRA-THIN BONDED WEARING COURSE.
 - 2) BACKFILL SHOULDER WITH APPROVED MATERIAL.
 - 3) THE SHOULDER WEDGE DEVICE MAY BE DISENGAGED AT PAVED DRIVEWAYS, SIDE STREETS, HIGH SHOULDERS, AND OTHER LOCATIONS NOT FEASIBLE TO CONSTRUCT AS APPROVED BY THE ENGINEER.

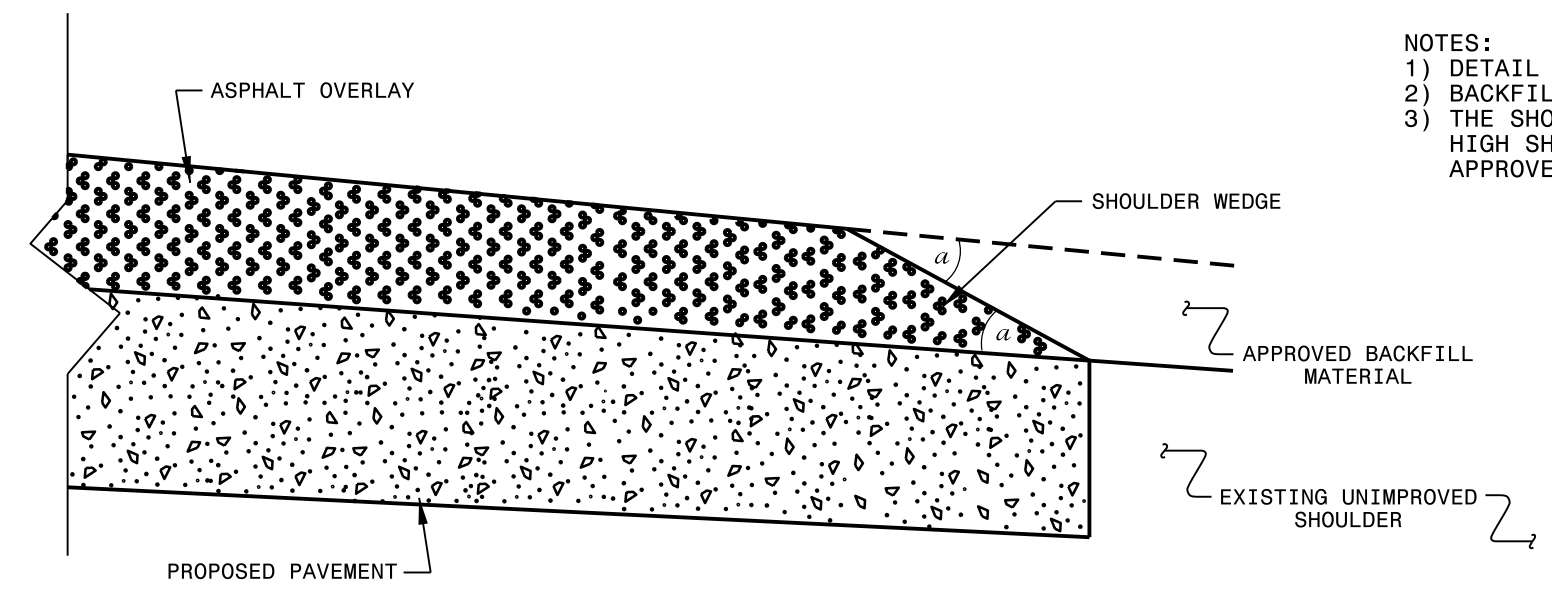

SHOULDER WEDGE DETAIL
 (Resurfacing Projects w/ Widening or
 with Existing Paved Shoulder having no dropoffs)

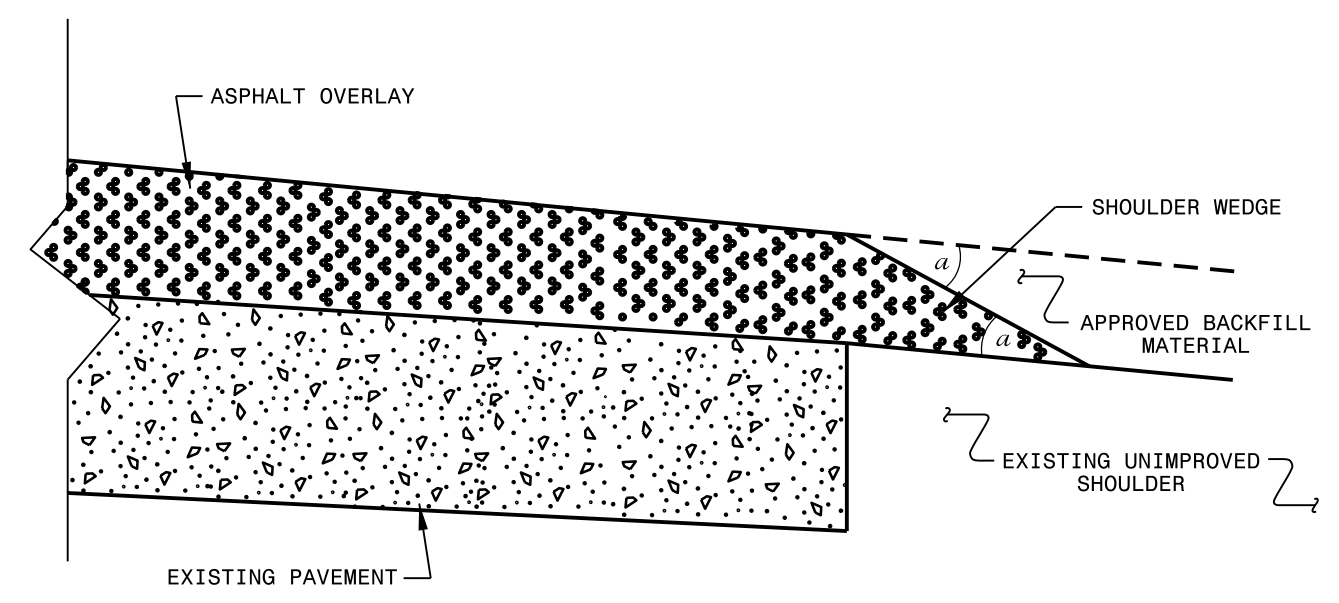

SHOULDER WEDGE DETAIL
 (Resurfacing Projects w/ NO Widening)

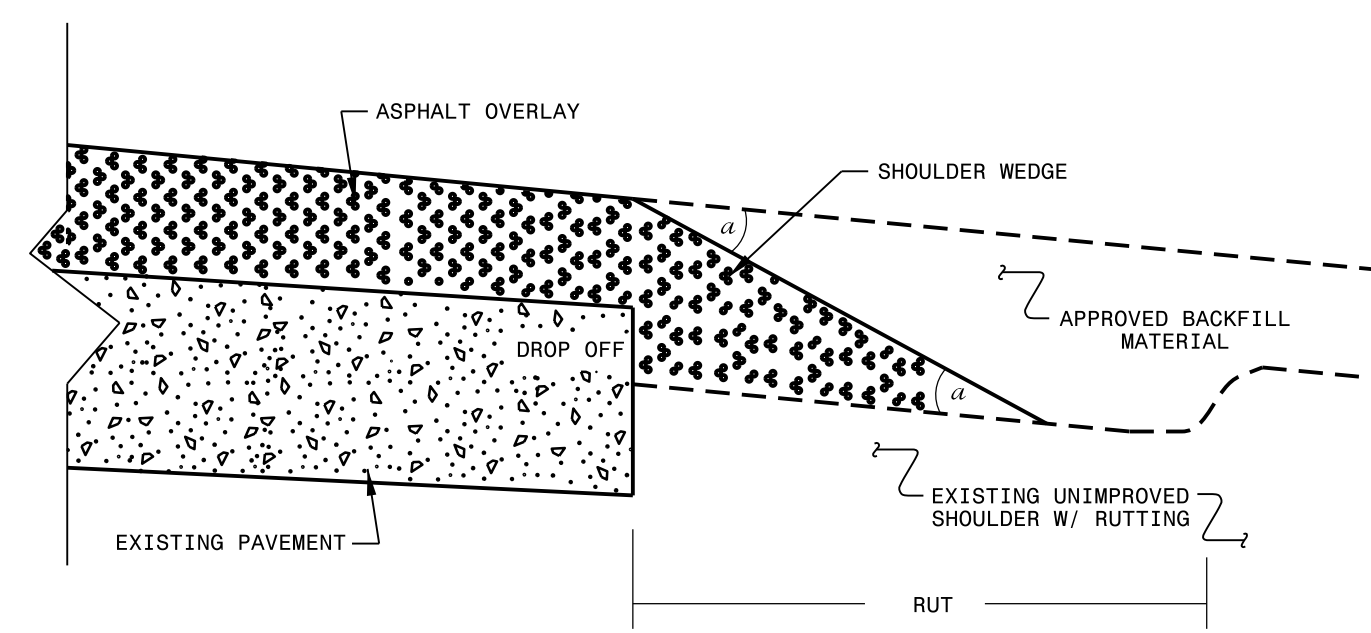

SHOULDER WEDGE DETAIL
 (Resurfacing Adjacent to
 Rutted Shoulder)

- SHOULDER WEDGE ANGLE = 30°

CONTRACT STANDARDS AND DEVELOPMENT UNIT			
Office 919-707-6950		FAX 919-250-4119	
SHOULDER WEDGE DETAILS			
ORIGINAL BY:	T.SPELL	DATE:	7-19-11
MODIFIED BY:		DATE:	2/2/16
CHECKED BY:		DATE:	
FILE SPEC.:	s:\usr\details\stand\shoulderwedgedetail.dgn		

27 JUN 2018 13:22:41 C:\Users\jporter\Documents\Projects\Resurfacing Projects\Division 3\Sampson August 2018\Revised Shoulder Wedge Detail.dgn
 jporter

PROJECT NO.	SHEET NO.
2022CPT.03.07.20101, Etc.	7

SUMMARY OF QUANTITIES

PROJECT NO	COUNTY	MAP NO	ROUTE	DESCRIPTION	TYP NO	LANES	LANE TYPE	FINAL SURFACE TESTING REQUIRED	WARM MIX ASPHALT REQUIRED	LENGTH	WIDTH	0106000000-E	1220000000-E	1245000000-E	1330000000-E	1519000000-E	1520000000-E	1526000000-E	1575000000-E	1880000000-E		2830000000-N	2845000000-N	6000000000-E	6009000000-E	6012000000-E							
												BORROW EXCAVATION	INCIDENTAL STONE BASE	SHOULDER RECONSTRUCTION	INCIDENTAL MILLING	SURFACE COURSE, \$9.58	LEVELING COURSE, \$9.58	SURFACE COURSE, \$4.75A	ASPHALT BINDER FOR PLANT MIX	PATCHING EXISTING PAVEMENT (MILL) GENERIC	PATCHING EXISTING PAVEMENT (FULL DEPTH) GENERIC	ADJUSTMENT OF MANHOLES	ADJUSTMENT OF METER OR VALVE BOX	TEMPORARY SILT FENCE	STONE FOR EC CLASS B	SEDIMENT CONTROL STONE							
												MI	FT	CY	TON	SMI	SY	TON	TON	TON	TON	TON	TON	EA	EA	LF	TON	TON					
2022CPT.03.07.20101	Brunswick	1	SR 1514 (MILL CREEK ROAD)	FROM US 17 HWY. (OCEAN HWY.) TO NC 87 HWY. (GEORGE II HWY.) [MP 0.05 - MP 2.60]	1	2	2WU	NO	NO	2.55	19	390	116	5.10	485	2,478	150	166	500					255	64	64							
TOTAL FOR MAP NO. 1												2.55		390	116	5.10	485	2,478	150	166	500						255	64	64				
2022CPT.03.07.20101	Brunswick	2	SR 1126 (MORGAN ROAD)	FROM SR 1130 (MT. PISGAH RD.) TO SR 1119 (STANLEY RD.) [MP 0.01 - MP 1.22]	1	2	2WU	NO	NO	1.21	20	185	60	2.42	225	1,238	60	83	400					121	30	30							
TOTAL FOR MAP NO. 2												1.21		185	60	2.42	225	1,238	60	83	400						121	30	30				
2022CPT.03.07.20101	Brunswick	3	SR 1128 (HEWETT ROAD)	FROM SR 1115 (STONE CHIMNEY RD. SW) TO SR 1119 (STANLEY RD. NW) [MP 0.00 - MP 1.24]	1	2	2WU	NO	NO	1.24	20	189	60	2.48	225	1,268	100	85	400					124	31	31							
TOTAL FOR MAP NO. 3												1.24		189	60	2.48	225	1,268	100	85	400						124	31	31				
2022CPT.03.07.20101	Brunswick	4	SR 1129 (TURNPIKE ROAD)	FROM SR 1115 (STONE CHIMNEY RD.) TO SR 1130 (MT. PISGAH RD.) [MP 0.01 - MP 1.59]	1	2	2WU	NO	NO	1.58	20	241	90	3.16	342	1,616	80	108	500					158	40	40							
TOTAL FOR MAP NO. 4												1.58		241	90	3.16	342	1,616	80	108	500						158	40	40				
TOTAL FOR PROJ NO. 2022CPT.03.07.20101												6.58		1,005	326	13.16	1,277	6,600	390	442	1,800							658	165	165			
2022CPT.03.07.20102	Brunswick	7	SR 1488 (NATIONAL AVE. NE)	FROM SR 1725 (LEXINGTON AVE. NE) TO SR 1607 (ECHO DR. NE) [MP 0.00 - MP 0.81]	2	2	2WU	NO	NO	0.81	21		14					566	40														
TOTAL FOR MAP NO. 7												0.81			14					566	40												
2022CPT.03.07.20102	Brunswick	8	SR 1489 (PARKWOOD DR. NE)	FROM SR 1437 (OLD FAYETTEVILLE RD. NE) TO SR 1488 (NATIONAL AVE. NE) [MP 0.01 - MP 0.32]	2	2	2WU	NO	NO	0.31	20		2					206	14														
TOTAL FOR MAP NO. 8												0.31			2					206	14												
2022CPT.03.07.20102	Brunswick	9	SR 1491 (WINSTON AVE. NE)	FROM SR 1437 (OLD FAYETTEVILLE RD. NE) TO SR 1488 (NATIONAL AVE. NE) [MP 0.00 - MP 0.07]	2	2	2WU	NO	NO	0.07	20							47	3					2									
TOTAL FOR MAP NO. 9												0.07								47	3							2					
2022CPT.03.07.20102	Brunswick	10	SR 1492 (DAVIDSON AVE. NE)	FROM SR 1488 (NATIONAL AVE. NE) TO SR 1488 (NATIONAL AVE. NE) [MP 0.01 - MP 0.20]	2	2	2WU	NO	NO	0.19	20		8					126	9														
TOTAL FOR MAP NO. 10												0.19			8					126	9												
2022CPT.03.07.20102	Brunswick	11	SR 1607 (ECHO DR. NE)	FROM SR 1488 (NATIONAL AVE. NE) TO SR 1608 (SALEM DR. NE) [MP 0.00 - MP 0.28]	2	2	2WU	NO	NO	0.28	21		2					196	14				5	2									
TOTAL FOR MAP NO. 11												0.28			2					196	14							5	2				
2022CPT.03.07.20102	Brunswick	12	SR 1608 (SALEM DR. NE)	FROM SR 1607 (ECHO DR. NE) TO 1725 (LEXINGTON AVE. NE) [MP 0.00 - MP 0.07]	2	2	2WU	NO	NO	0.07	20							47	3					2									
TOTAL FOR MAP NO. 12												0.07								47	3								2				
2022CPT.03.07.20102	Brunswick	13	SR 1724 (PADDINGTON AVE. NE)	FROM 1488 (NATIONAL AVE. NE) TO 1488 (NATIONAL AVE. NE) [MP 0.00 - MP 0.33]	2	2	2WU	NO	NO	0.33	20							220	15				6										
TOTAL FOR MAP NO. 13												0.33								220	15							6					
2022CPT.03.07.20102	Brunswick	14	SR 1725 (LEXINGTON AVE. NE)	FROM 1488 (NATIONAL AVE. NE) TO SR 1488 (NATIONAL AVE. NE) [MP 0.00 - MP 0.39]	2	2	2WU	NO	NO	0.39	20		12					260	18														
TOTAL FOR MAP NO. 14												0.39			12					260	18												
2022CPT.03.07.20102	Brunswick	15	SR 1712 (INDUSTRIAL BLVD. NE)	FROM SR 1426 (MT. MISERY RD. NE) TO END OF MAINTENANCE [MP 0.00 - MP 0.39]	2	2	2WU	NO	NO	0.39	21		20					273	19					35									
TOTAL FOR MAP NO. 15												0.39			20					273	19								35				
2022CPT.03.07.20102	Brunswick	16	SR 1713 (POPULAR ST. NE)	FROM US 74/76 (ANDREW JACKSON HWY.) TO END OF MAINTENANCE [MP 0.00 - MP 0.28]	2	2	2WU	NO	NO	0.28	22		8					205	14														
TOTAL FOR MAP NO. 16												0.28			8					205	14												
2022CPT.03.07.20102	Brunswick	17	SR 1714 (POPULAR ST. NE / ENTERPRISE DR. NE)	FROM US 74/76 (ANDREW JACKSON HWY.) TO END OF MAINTENANCE [MP 0.00 - MP 0.39]	2	2	2WU	NO	NO	0.39	23							298	21				20	1									
TOTAL FOR MAP NO. 17												0.39								298	21								20	1			
2022CPT.03.07.20102	Brunswick	18	SR 1440 (CHURCH RD. NE)	FROM SR 1437 (OLD FAYETTEVILLE RD.) TO END OF MAINTENANCE [MP 0.00 - MP 0.21]	2	2	2WU	NO	NO	0.21	21							147	10				6										
TOTAL FOR MAP NO. 18												0.21								147	10								6				
TOTAL FOR PROJ NO. 2022CPT.03.07.20102												3.72			66					2,591	180								72	3	4		
GRAND TOTAL												10.3		1,005	392	13.16	1,277	6,600	390	2,591	622	1,800	72	3	4	658	165	165					

PROJECT NO.	SHEET NO.
2022CPT.03.07.20101, Etc.	8

SUMMARY OF QUANTITIES

PROJECT NO	COUNTY	MAP NO	ROUTE	DESCRIPTION	TYP NO	LANES	LANE TYPE	FINAL SURFACE TESTING REQUIRED	WARM MIX ASPHALT REQUIRED	LENGTH	WIDTH	601500000-E	601800000-E	602100000-E	603600000-E	604200000-E	607101000-E	608400000-E	609000000-E	609300000-E	611700000-N		
												TEMPORARY MULCHING	SEED FOR TEMPORARY SEEDING	FERTILIZER FOR TEMPORARY SEEDING	MATTING FOR EROSION CONTROL	1/4" HARDWARE CLOTH	WATTLE	SEED & MULCHING	SEED FOR REPAIR SEEDING	FERTILIZER FOR REPAIR SEEDING	RESPONSE FOR EROSION CONTROL		
												MI	FT	ACR	LBS	TON	SY	LF	LF	AC	LB	TON	EA
2022CPT.03.07.20101	Brunswick	1	SR 1514 (MILL CREEK ROAD)	FROM US 17 HWY. (OCEAN HWY.) TO NC 87 HWY. (GEORGE II HWY.) [MP 0.05 - MP 2.60]	1	2	2WU	NO	NO	2.55	19	2.55	128	0.64	20	128	40	2.47	128	0.64	6		
TOTAL FOR MAP NO. 1											2.55		2.55	128	0.64	20	128	40	2.47	128	0.64	6	
2022CPT.03.07.20101	Brunswick	2	SR 1126 (MORGAN ROAD)	FROM SR 1130 (MT. PISGAH RD.) TO SR 1119 (STANLEY RD.) [MP 0.01 - MP 1.22]	1	2	2WU	NO	NO	1.21	20	1.21	61	0.30	10	61	20	1.17	61	0.30	2		
TOTAL FOR MAP NO. 2											1.21		1.21	61	0.30	10	61	20	1.17	61	0.30	2	
2022CPT.03.07.20101	Brunswick	3	SR 1128 (HEWETT ROAD)	FROM SR 1115 (STONE CHIMNEY RD. SW) TO SR 1119 (STANLEY RD. NW) [MP 0.00 - MP 1.24]	1	2	2WU	NO	NO	1.24	20	1.24	62	0.31	10	62	20	1.20	62	0.31	2		
TOTAL FOR MAP NO. 3											1.24		1.24	62	0.31	10	62	20	1.20	62	0.31	2	
2022CPT.03.07.20101	Brunswick	4	SR 1129 (TURNPIKE ROAD)	FROM SR 1115 (STONE CHIMNEY RD.) TO SR 1130 (MT. PISGAH RD.) [MP 0.01 - MP 1.59]	1	2	2WU	NO	NO	1.58	20	1.58	80	0.40	20	80	30	1.53	80	0.40	4		
TOTAL FOR MAP NO. 4											1.58		1.58	80	0.40	20	80	30	1.53	80	0.40	4	
TOTAL FOR PROJ NO. 2022CPT.03.07.20101											6.58		6.58	331	1.65	60	331	110	6.37	331	1.65	14	
2022CPT.03.07.20102	Brunswick	7	SR 1488 (NATIONAL AVE. NE)	FROM SR 1725 (LEXINGTON AVE. NE) TO SR 1607 (ECHO DR. NE) [MP 0.00 - MP 0.81]	2	2	2WU	NO	NO	0.81	21												
TOTAL FOR MAP NO. 7											0.81												
2022CPT.03.07.20102	Brunswick	8	SR 1489 (PARKWOOD DR. NE)	FROM SR 1437 (OLD FAYETTEVILLE RD. NE) TO SR 1488 (NATIONAL AVE. NE) [MP 0.01 - MP 0.32]	2	2	2WU	NO	NO	0.31	20												
TOTAL FOR MAP NO. 8											0.31												
2022CPT.03.07.20102	Brunswick	9	SR 1491 (WINSTON AVE. NE)	FROM SR 1437 (OLD FAYETTEVILLE RD. NE) TO SR 1488 (NATIONAL AVE. NE) [MP 0.00 - MP 0.07]	2	2	2WU	NO	NO	0.07	20												
TOTAL FOR MAP NO. 9											0.07												
2022CPT.03.07.20102	Brunswick	10	SR 1492 (DAVIDSON AVE. NE)	FROM SR 1488 (NATIONAL AVE. NE) TO SR 1488 (NATIONAL AVE. NE) [MP 0.01 - MP 0.20]	2	2	2WU	NO	NO	0.19	20												
TOTAL FOR MAP NO. 10											0.19												
2022CPT.03.07.20102	Brunswick	11	SR 1607 (ECHO DR. NE)	FROM SR 1488 (NATIONAL AVE. NE) TO SR 1608 (SALEM DR. NE) [MP 0.00 - MP 0.28]	2	2	2WU	NO	NO	0.28	21												
TOTAL FOR MAP NO. 11											0.28												
2022CPT.03.07.20102	Brunswick	12	SR 1608 (SALEM DR. NE)	FROM SR 1607 (ECHO DR. NE) TO 1725 (LEXINGTON AVE. NE) [MP 0.00 - MP 0.07]	2	2	2WU	NO	NO	0.07	20												
TOTAL FOR MAP NO. 12											0.07												
2022CPT.03.07.20102	Brunswick	13	SR 1724 (PADDINGTON AVE. NE)	FROM 1488 (NATIONAL AVE. NE) TO 1488 (NATIONAL AVE. NE) [MP 0.00 - MP 0.33]	2	2	2WU	NO	NO	0.33	20												
TOTAL FOR MAP NO. 13											0.33												
2022CPT.03.07.20102	Brunswick	14	SR 1725 (LEXINGTON AVE. NE)	FROM 1488 (NATIONAL AVE. NE) TO SR 1488 (NATIONAL AVE. NE) [MP 0.00 - MP 0.39]	2	2	2WU	NO	NO	0.39	20												
TOTAL FOR MAP NO. 14											0.39												
2022CPT.03.07.20102	Brunswick	15	SR 1712 (INDUSTRIAL BLVD. NE)	FROM SR 1426 (MT. MISERY RD. NE) TO END OF MAINTENANCE [MP 0.00 - MP 0.39]	2	2	2WU	NO	NO	0.39	21												
TOTAL FOR MAP NO. 15											0.39												
2022CPT.03.07.20102	Brunswick	16	SR 1713 (POPULAR ST. NE)	FROM US 74/76 (ANDREW JACKSON HWY.) TO END OF MAINTENANCE [MP 0.00 - MP 0.28]	2	2	2WU	NO	NO	0.28	22												
TOTAL FOR MAP NO. 16											0.28												
2022CPT.03.07.20102	Brunswick	17	SR 1714 (POPULAR ST. NE / ENTERPRISE DR. NE)	FROM US 74/76 (ANDREW JACKSON HWY.) TO END OF MAINTENANCE [MP 0.00 - MP 0.39]	2	2	2WU	NO	NO	0.39	23												
TOTAL FOR MAP NO. 17											0.39												
2022CPT.03.07.20102	Brunswick	18	SR 1440 (CHURCH RD. NE)	FROM SR 1437 (OLD FAYETTEVILLE RD.) TO END OF MAINTENANCE [MP 0.00 - MP 0.21]	2	2	2WU	NO	NO	0.21	21												
TOTAL FOR MAP NO. 18											0.21												
TOTAL FOR PROJ NO. 2022CPT.03.07.20102											3.72												
GRAND TOTAL											10.3		6.58	331	1.65	60	331	110	6.37	331	1.65	14	

PROJECT NO.	SHEET NO.
2022CPT.03.07.20101, Etc.	9

THERMOPLASTIC AND PAINT QUANTITIES

PROJECT NO	COUNTY	MAP NO	ROUTE	DESCRIPTION	TYP NO	LANES	LANE TYPE	LENGTH	WIDTH	4413000000-E	4457000000-N	4720000000-E	4810000000-E		4891000000-E	4900000000-N	
										WORK ZONE ADVANCE/ GENERAL WARNING SIGNING	TEMPORARY TRAFFIC CONTROL	THERMO RXR 90 MILS	4" WHITE PAINT	4" YELLOW PAINT	GENERIC MARKING, 24" X 90 M WHITE THERMO	YELLOW & YELLOW MARKERS	
										SF	LS	EA	LF	LF	LF	EA	
2022CPT.03.07.20101	Brunswick	1	SR 1514 (MILL CREEK ROAD)	FROM US 17 HWY. (OCEAN HWY.) TO NC 87 HWY. (GEORGE II HWY.) [MP 0.05 - MP 2.60]	1	2	2WU	2.55	19								173
TOTAL FOR MAP NO. 1																	173
2022CPT.03.07.20101	Brunswick	2	SR 1126 (MORGAN ROAD)	FROM SR 1130 (MT. PISGAH RD.) TO SR 1119 (STANLEY RD.) [MP 0.01 - MP 1.22]	1	2	2WU	1.21	20								82
TOTAL FOR MAP NO. 2																	82
2022CPT.03.07.20101	Brunswick	3	SR 1128 (HEWETT ROAD)	FROM SR 1115 (STONE CHIMNEY RD. SW) TO SR 1119 (STANLEY RD. NW) [MP 0.00 - MP 1.24]	1	2	2WU	1.24	20								85
TOTAL FOR MAP NO. 3																	85
2022CPT.03.07.20101	Brunswick	4	SR 1129 (TURNPIKE ROAD)	FROM SR 1115 (STONE CHIMNEY RD.) TO SR 1130 (MT. PISGAH RD.) [MP 0.01 - MP 1.59]	1	2	2WU	1.58	20								106
TOTAL FOR MAP NO. 4																	106
TOTAL FOR PROJ NO. 2022CPT.03.07.20101										6.58	80	*	141,602	105,838			446
TOTAL FOR PROJ NO. 2022CPT.03.07.20101													247,440				446
2022CPT.03.07.20102	Brunswick	7	SR 1488 (NATIONAL AVE. NE)	FROM SR 1725 (LEXINGTON AVE. NE) TO SR 1607 (ECHO DR. NE) [MP 0.00 - MP 0.81]	2	2	2WU	0.81	21								
TOTAL FOR MAP NO. 7																	
2022CPT.03.07.20102	Brunswick	8	SR 1489 (PARKWOOD DR. NE)	FROM SR 1437 (OLD FAYETTEVILLE RD. NE) TO SR 1488 (NATIONAL AVE. NE) [MP 0.01 - MP 0.32]	2	2	2WU	0.31	20								
TOTAL FOR MAP NO. 8																	
2022CPT.03.07.20102	Brunswick	9	SR 1491 (WINSTON AVE. NE)	FROM SR 1437 (OLD FAYETTEVILLE RD. NE) TO SR 1488 (NATIONAL AVE. NE) [MP 0.00 - MP 0.07]	2	2	2WU	0.07	20								
TOTAL FOR MAP NO. 9																	
2022CPT.03.07.20102	Brunswick	10	SR 1492 (DAVIDSON AVE. NE)	FROM SR 1488 (NATIONAL AVE. NE) TO SR 1488 (NATIONAL AVE. NE) [MP 0.01 - MP 0.20]	2	2	2WU	0.19	20								
TOTAL FOR MAP NO. 10																	
2022CPT.03.07.20102	Brunswick	11	SR 1607 (ECHO DR. NE)	FROM SR 1488 (NATIONAL AVE. NE) TO SR 1608 (SALEM DR. NE) [MP 0.00 - MP 0.28]	2	2	2WU	0.28	21								
TOTAL FOR MAP NO. 11																	
2022CPT.03.07.20102	Brunswick	12	SR 1608 (SALEM DR. NE)	FROM SR 1607 (ECHO DR. NE) TO 1725 (LEXINGTON AVE. NE) [MP 0.00 - MP 0.07]	2	2	2WU	0.07	20								
TOTAL FOR MAP NO. 12																	
2022CPT.03.07.20102	Brunswick	13	SR 1724 (PADDINGTON AVE. NE)	FROM 1488 (NATIONAL AVE. NE) TO 1488 (NATIONAL AVE. NE) [MP 0.00 - MP 0.33]	2	2	2WU	0.33	20								
TOTAL FOR MAP NO. 13																	
2022CPT.03.07.20102	Brunswick	14	SR 1725 (LEXINGTON AVE. NE)	FROM 1488 (NATIONAL AVE. NE) TO SR 1488 (NATIONAL AVE. NE) [MP 0.00 - MP 0.39]	2	2	2WU	0.39	20								
TOTAL FOR MAP NO. 14																	
2022CPT.03.07.20102	Brunswick	15	SR 1712 (INDUSTRIAL BLVD. NE)	FROM SR 1426 (MT. MISERY RD. NE) TO END OF MAINTENANCE [MP 0.00 - MP 0.39]	2	2	2WU	0.39	21								
TOTAL FOR MAP NO. 15																	
2022CPT.03.07.20102	Brunswick	16	SR 1713 (POPULAR ST. NE)	FROM US 74/76 (ANDREW JACKSON HWY.) TO END OF MAINTENANCE [MP 0.00 - MP 0.28]	2	2	2WU	0.28	22								25
TOTAL FOR MAP NO. 16																	25
2022CPT.03.07.20102	Brunswick	17	SR 1714 (POPULAR ST. NE / ENTERPRISE DR. NE)	FROM US 74/76 (ANDREW JACKSON HWY.) TO END OF MAINTENANCE [MP 0.00 - MP 0.39]	2	2	2WU	0.39	23					4,000	2,400		26
TOTAL FOR MAP NO. 17														4,000	2,400		26
2022CPT.03.07.20102	Brunswick	18	SR 1440 (CHURCH RD. NE)	FROM SR 1437 (OLD FAYETTEVILLE RD.) TO END OF MAINTENANCE [MP 0.00 - MP 0.21]	2	2	2WU	0.21	21								
TOTAL FOR MAP NO. 18																	
TOTAL FOR PROJ NO. 2022CPT.03.07.20102										3.72		*	2	4,000	2,400	25	26
TOTAL FOR PROJ NO. 2022CPT.03.07.20102														6,400			26
GRAND TOTAL										10.3	80	1.00	2	145,602	108,238	25	472
GRAND TOTAL														253,840			472