

AT END OF GIRDER AT C OF GIRDER

0.6" Ø LOW RELAXATION STRAND LAYOUT

- ▲ STRANDS DEBONDED FOR A DISTANCE OF 8'-0" FROM END OF GIRDER.
- OPTIONAL FULLY DEBONDED STRANDS.

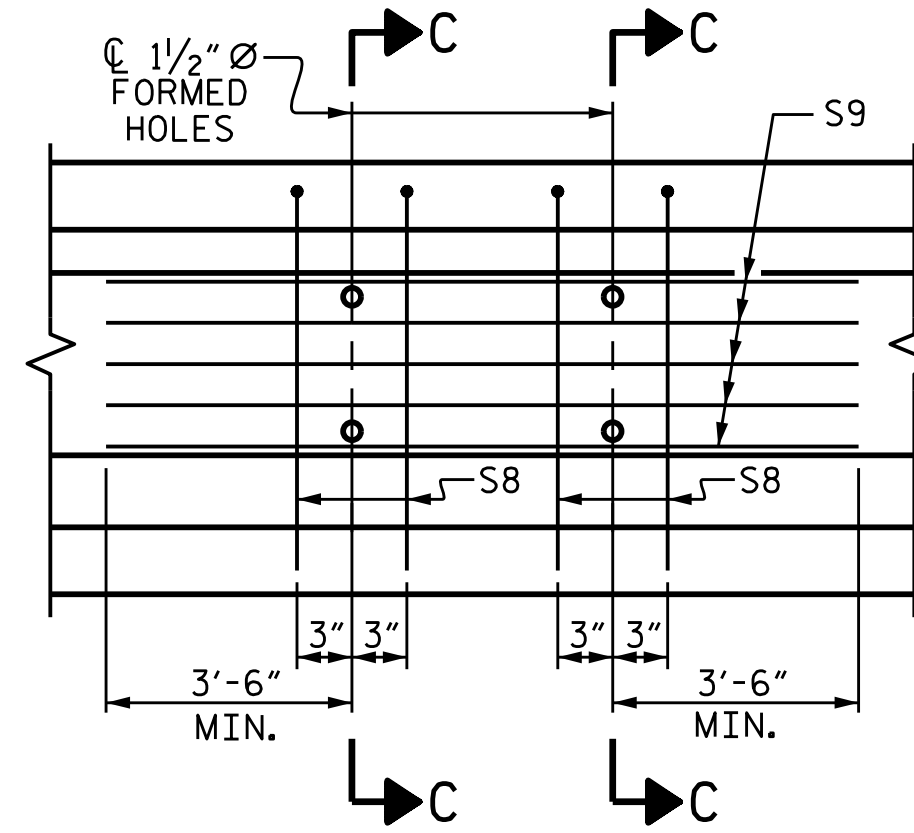

PARTIAL ELEVATION

SHOWING INTERMEDIATE DIAPHRAGM REINFORCING STEEL FOR GIRDERS 2-4.

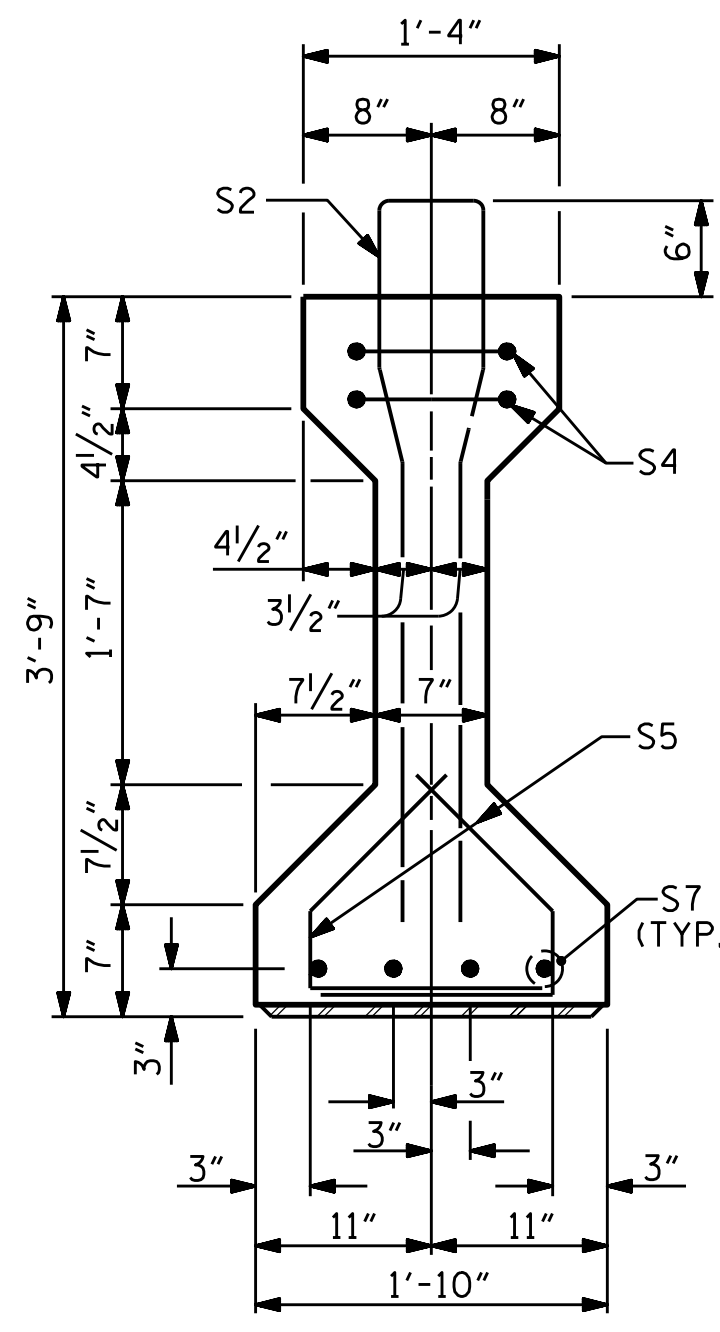

SECTION B-B

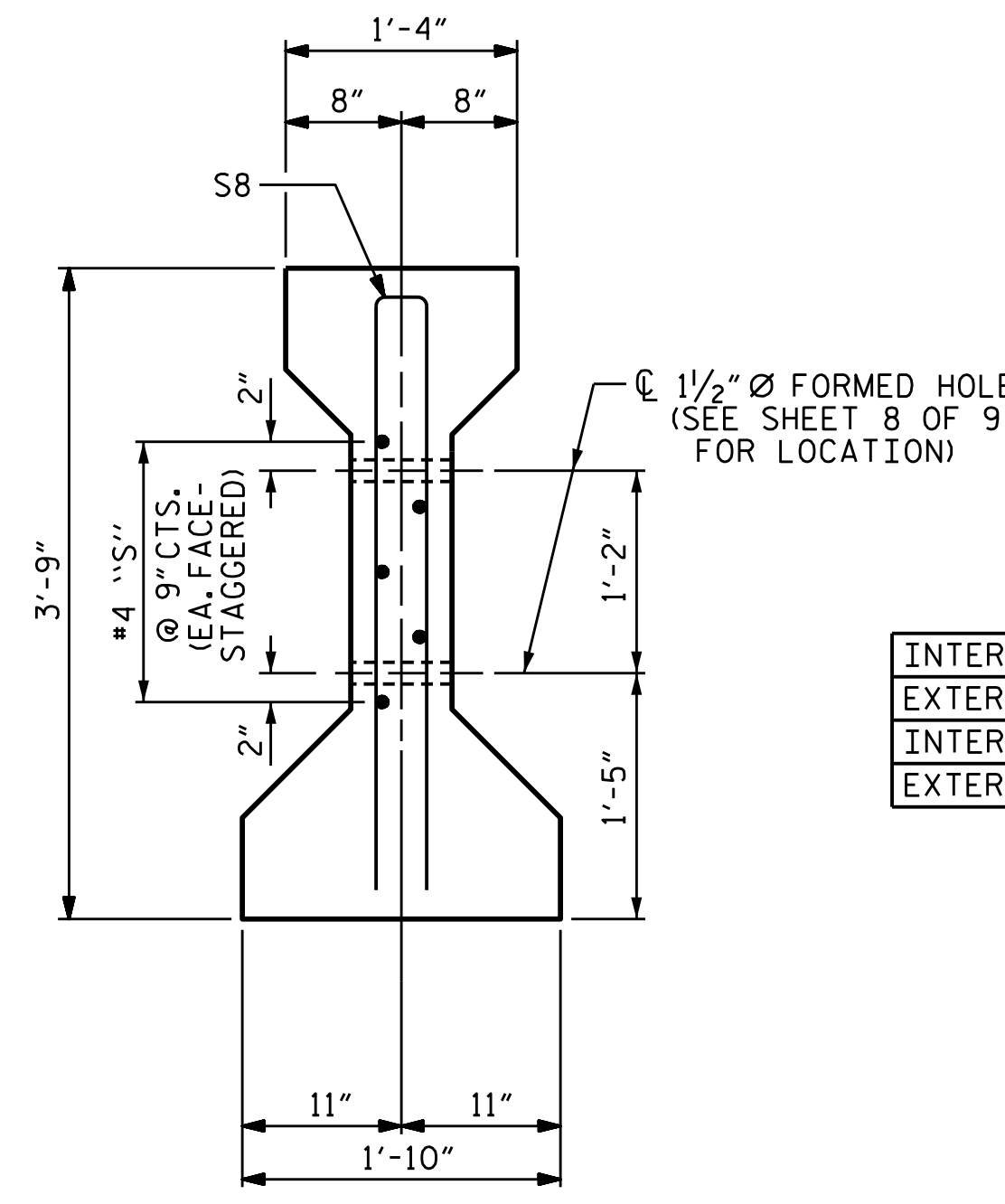

SECTION C-C

(S3 BARS NOT SHOWN)

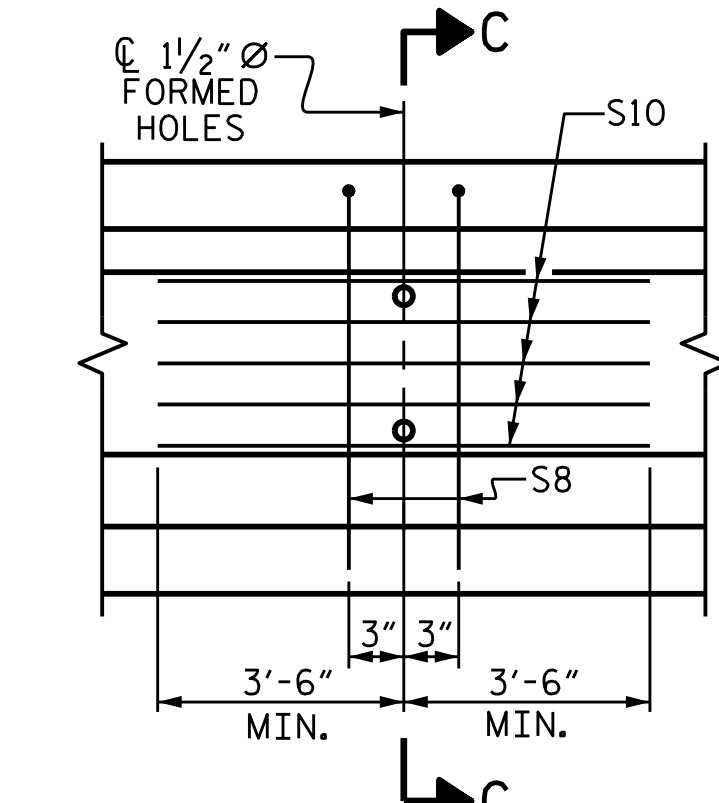

PARTIAL ELEVATION

SHOWING INTERMEDIATE DIAPHRAGM REINFORCING STEEL FOR GIRDERS 1 & 5.

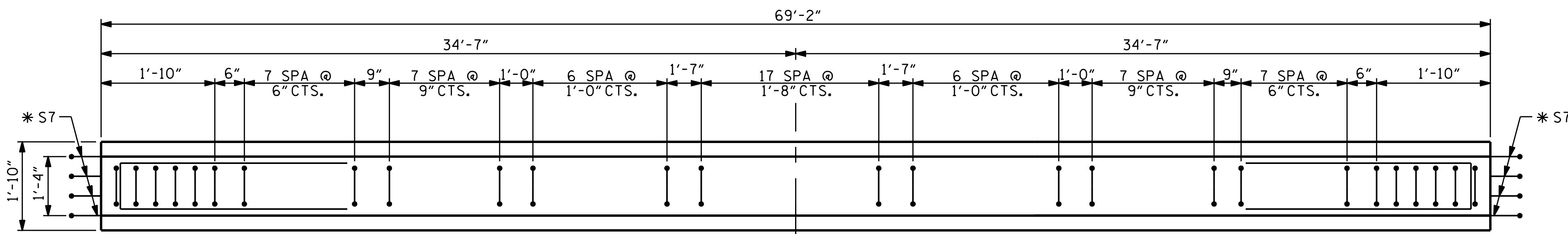

ELEVATION OF GIRDER

0.6" Ø L. R. GRADE 270 STRANDS		
AREA (SQUARE INCHES)	ULTIMATE STRENGTH (LBS. PER STRAND)	APPLIED PRESTRESS (LBS. PER STRAND)
0.217	58,600	43,950

REINFORCING STEEL FOR ONE GIRDER					
BAR	NUMBER	SIZE	TYPE	LENGTH	WEIGHT
S1	16	#5	1	8'-6"	142
S2	12	#6	1	8'-6"	153
S3	48	#4	1	8'-6"	273
S4	4	#4	3	8'-8"	23
S5	56	#4	2	2'-9"	103
*S7	8	#5	STR	3'-8"	31
INTERIOR S8	4	#5	3	7'-2"	30
EXTERIOR S8	2	#5	3	7'-2"	15
INTERIOR S9	5	#4	STR	12'-0"	40
EXTERIOR S10	5	#4	STR	7'-0"	23

* NOTE: S7 BARS SHALL BE BENT BEFORE SHIPMENT. HEAT BENDING SHALL NOT BE ALLOWED.

BAR TYPES

ALL BAR DIMENSIONS ARE OUT-TO-OUT

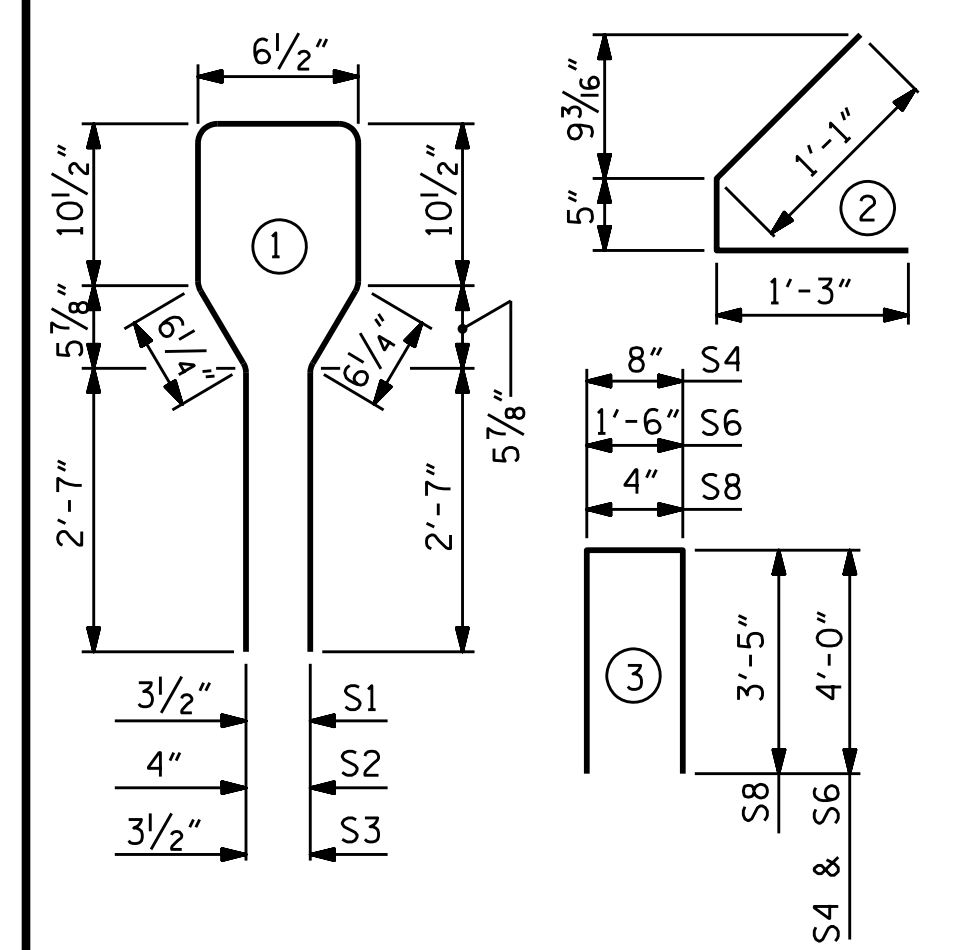

QUANTITIES FOR ONE GIRDER

	REINFORCING STEEL LB.	7,000 PSI CONCRETE C.Y.	0.6" Ø L. R. STRANDS No.
GIRDER 2-4	795	10.0	24
GIRDER 1 & 5	763	10.0	24

GIRDERS REQUIRED

NUMBER	LENGTH	TOTAL LENGTH
5	69'-2"	345'-10"

PROJECT NO. B-4786
 PITT COUNTY
 STATION: 28+03.00 -L-

SHEET 2 OF 9

STATE OF NORTH CAROLINA
 DEPARTMENT OF TRANSPORTATION
 RALEIGH

STANDARD
 AASHTO TYPE III
 PRESTRESSED CONCRETE GIRDER
 CONTINUOUS FOR LIVE LOAD
 SPAN B

9/24/2021
 X:\MCDOT\B-4786\Structures\Final plans\DCNs\401.037.B4786.SMU.G2.018.dgn
 User: sbwilliams

2/24/2022 | 7:41 AM EST

DOCUMENT NOT CONSIDERED FINAL
 UNLESS ALL SIGNATURES COMPLETED

TGS ENGINEERS
 706 HILLSBOROUGH STREET
 SUITE 200
 RALEIGH, NC 27603
 PH (919) 773-8887
 CORP. LICENSE NO.: C-0275

REVISIONS						SHEET NO.
NO.	BY:	DATE:	NO.	BY:	DATE:	S-18
1			3			TOTAL SHEETS
2			4			57

ASSEMBLED BY :	STM	DATE :	08/21
CHECKED BY :	MGC	DATE :	08/21
DESIGN ENGINEER OF RECORD :	STM	DATE :	08/21
DRAWN BY :	ELR 8/91	REV. 10/1/11	MAA/GM
CHECKED BY :	GRP 8/91	REV. 1/15	MAA/TMC
		REV. 12/17	MAA/THC