

PLOT DRIVER: NCDOT_pdf_color_eng_50.plt PENTABLE: NCDOT_tcp.tbl
 USER: CHARNDEN DATE: 1/21/2022 TIME: 4:11:04 PM
 FILE: p:\p\pdr\users\01\HDR\US_East_01\Documents\3322\10030389\6.0_CAD_BIM\6.2_Work_In_Progress\B-3186-B-5898_TrafficControl\TCP\B3186-B5898-TMP_TMP39.dgn

REVISIONS

APPROVED: *Michael T. Rzepka*

DATE: 3/17/2022

SEAL

DOCUMENT NOT CONSIDERED FINAL UNLESS ALL SIGNATURES COMPLETED

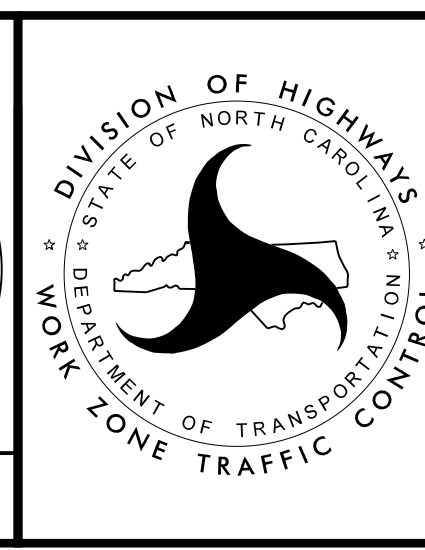

**PHASE 3
STEPS 2 & 2A**

PROJ. REFERENCE NO.	SHEET NO.
B-3186 / B-5898	TMP-40
 HDR Engineering, Inc. of the Carolinas 535 Fayetteville St, Suite 900 Raleigh, N.C. 27601 N.C.E.E.L.S. License Number: F-0116	

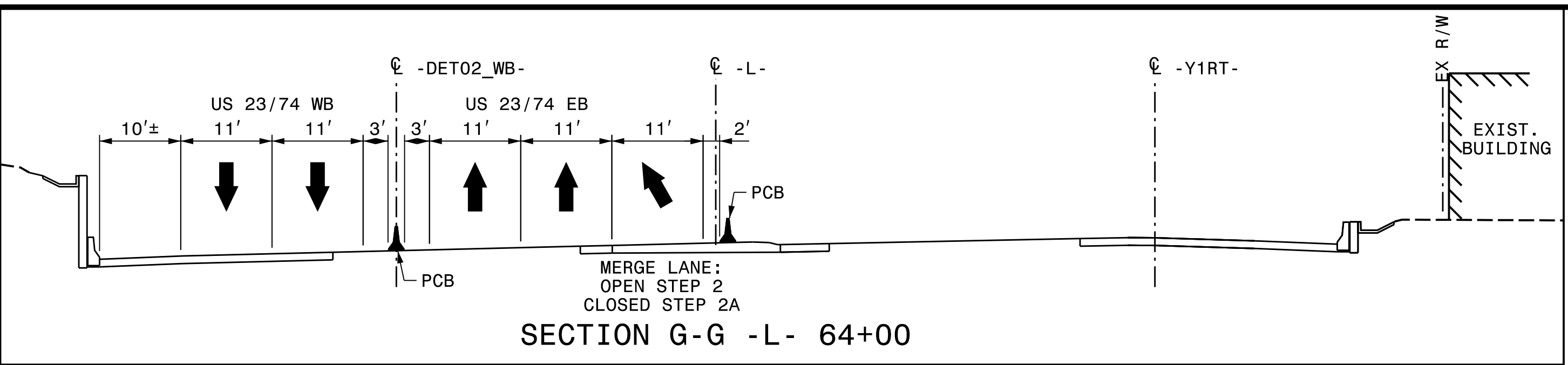

-L RT- STA. 67+84 +/-
 -DET02 EB- STA. 67+70 +/-
 END PCB @ 2' OFFSET, TIE TO BRIDGE

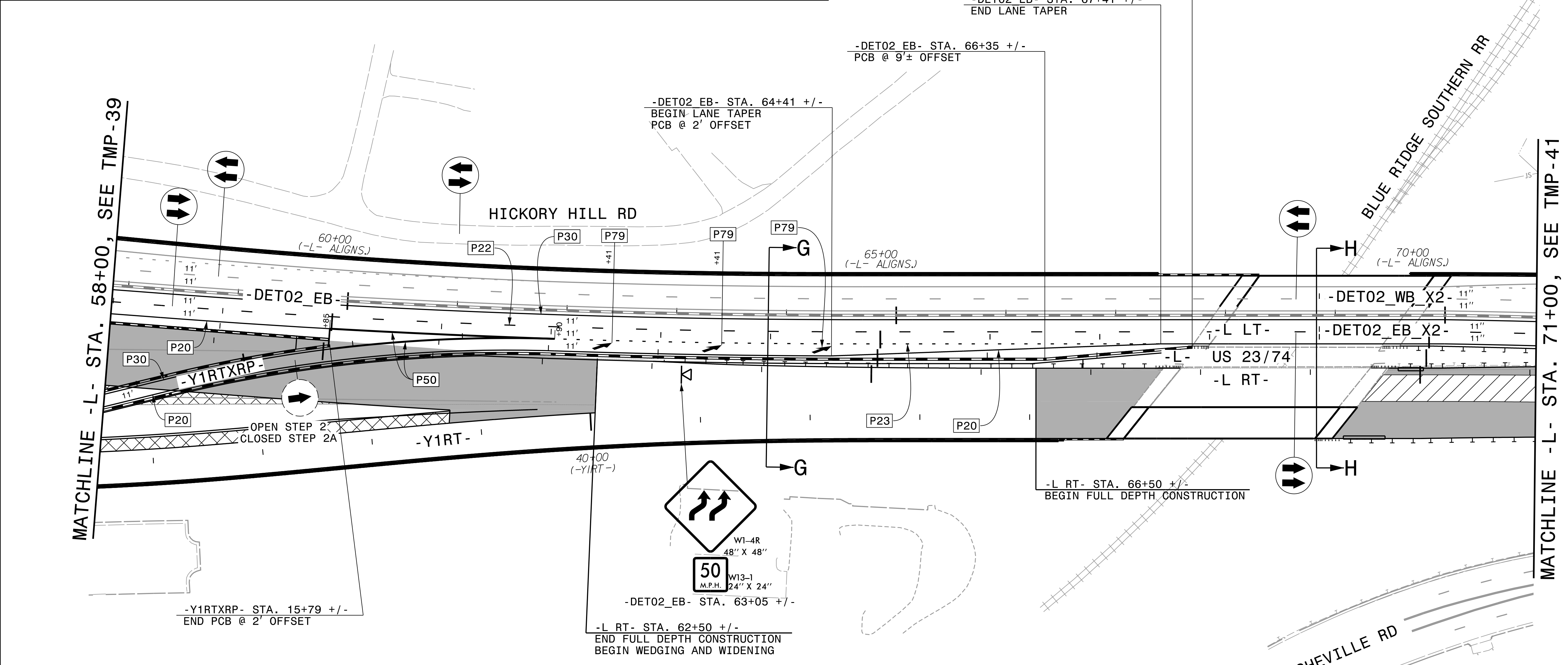

MATCHLINE -L- STA. 58+00, SEE TMP-39

MATCHLINE -L- STA. 71+00, SEE TMP-41

STEP 2A: COMPLETE UNDER 18 DAY ICT
 CONSTRUCT -L RT- FROM STA. 58+00 +/- TO STA. 62+50 +/-.
 THEN REOPEN TRAFFIC INTO THE PHASE 3, STEP 2 OR
 SHIFT TRAFFIC TO THE PHASE 4, STEP 1 PATTERN.
 CLOSURE WILL END WITH SHIFT OF EB US 23/74 TRAFFIC
 TO FINAL PATTERN.

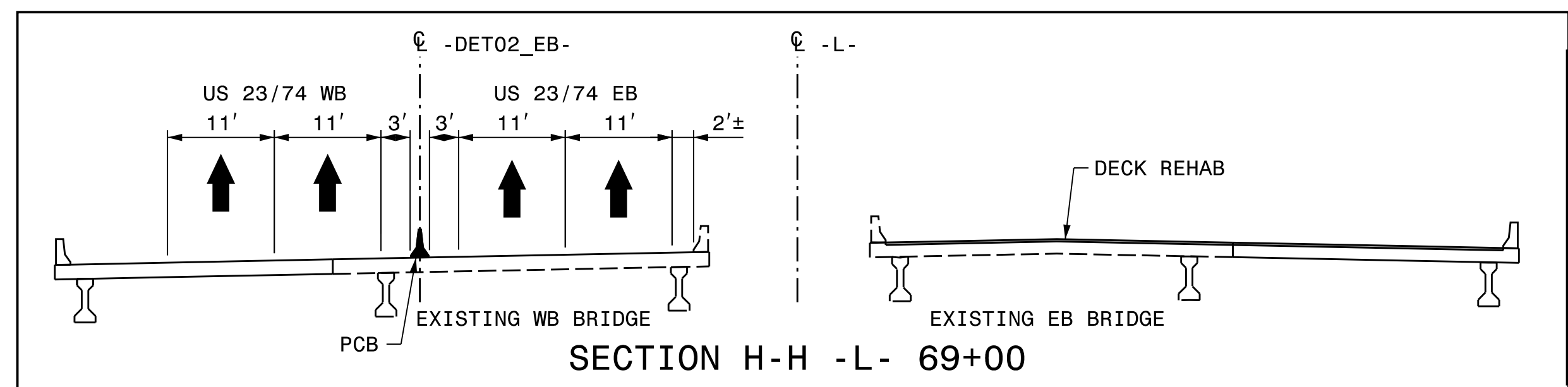

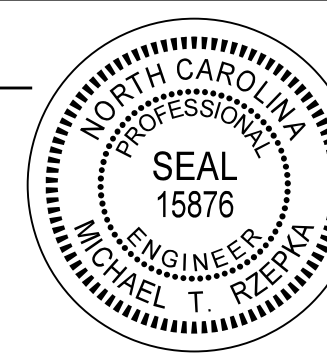
APPROVED: *Michael T. Rzepka*
 DATE: 4/11/2022
 SEAL

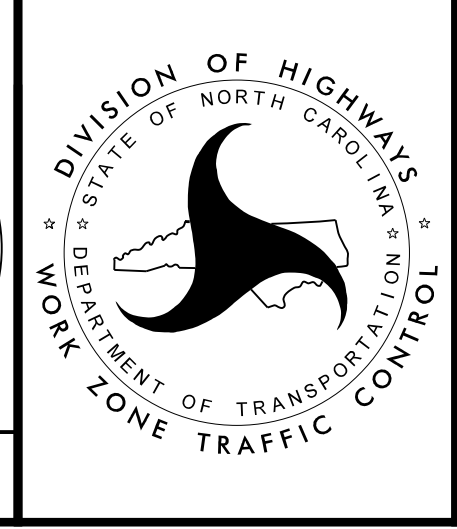
 DOCUMENT NOT CONSIDERED FINAL
 UNLESS ALL SIGNATURES COMPLETED



PHASE 3
 STEPS 2 & 2A

PLOT DRIVER: NCDOT_pdf_color_eng_50.pit
 USER: CHARNDEN
 FILE: p:\p\pndr\users\01\HDR_US_East_01\Documents\3322\10030389\6.0-CAD-BIM\6.2-Work_In_Progress\B-3186-B-5898-TrafficControl\TCP\B3186-B5898-TMP_TMP40.dgn

REVISIONS

PENTABLE: NCDOT_tcp.tbl
 TIME: 2:06:42 PM

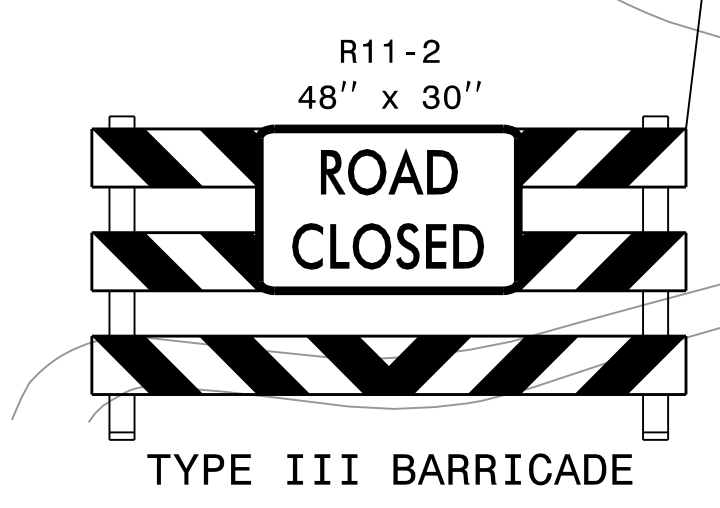
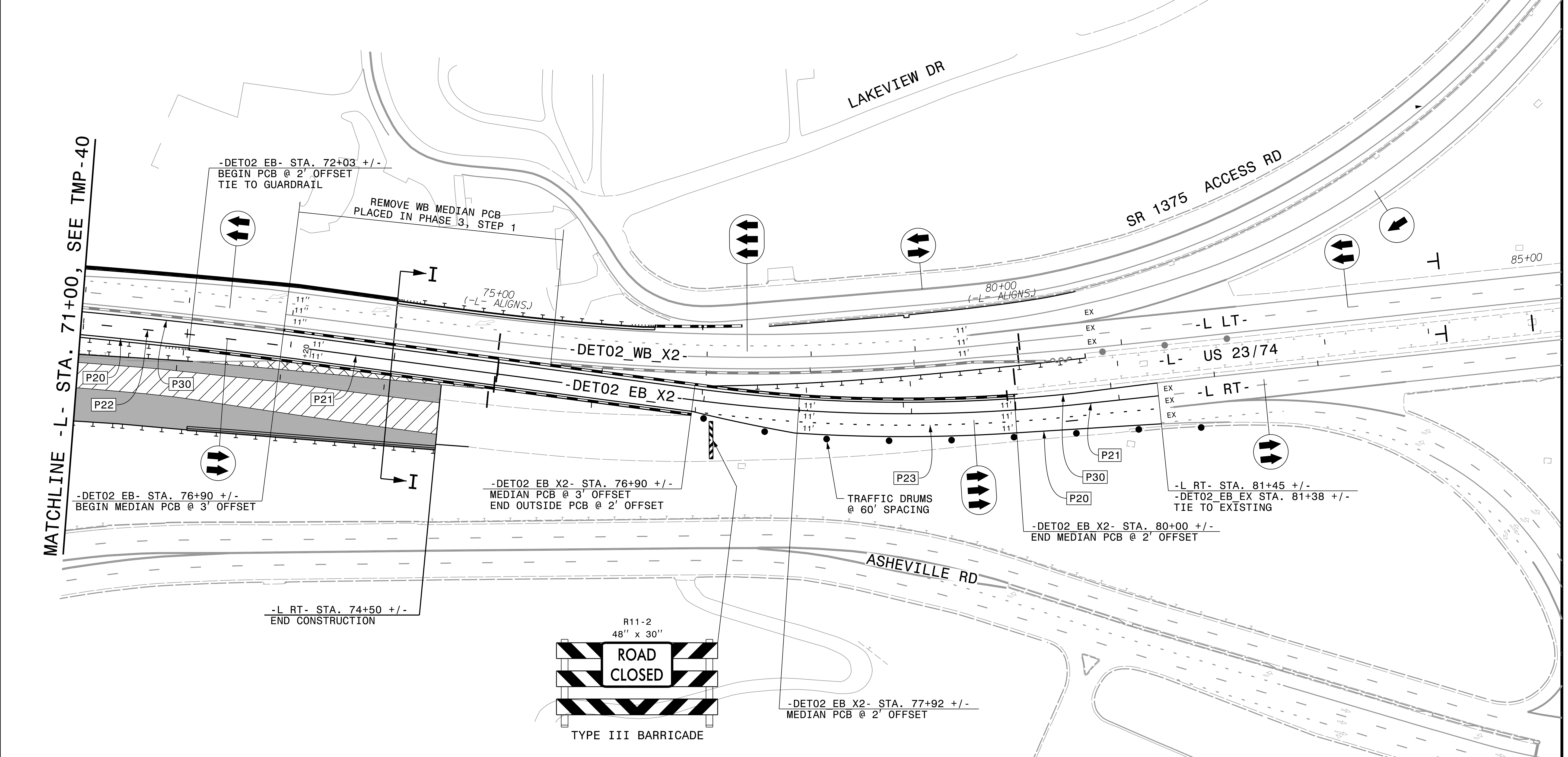
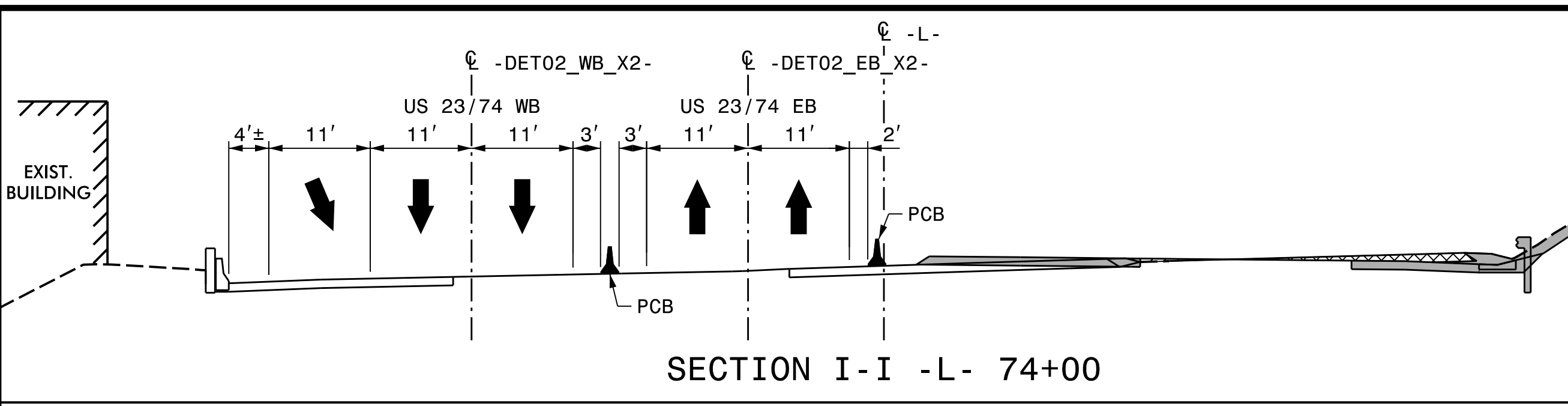

APPROVED: *Michael T. Rzepka*

DATE: 3/17/2022

SEAL

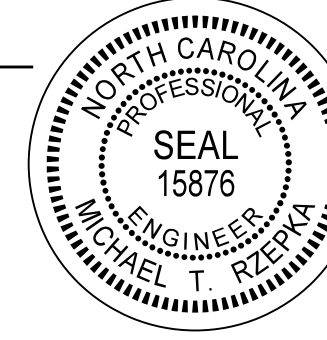

DOCUMENT NOT CONSIDERED FINAL UNLESS ALL SIGNATURES COMPLETED



DIVISION OF HIGHWAYS
STATE OF NORTH CAROLINA
DEPARTMENT OF TRANSPORTATION
WORK ZONE TRAFFIC CONTROL

PHASE 3, STEP 2

PLOT DRIVER: NCDOT_pdf_color_eng_50.pit
 USER: CHARNDEN
 DATE: 1/21/2022
 TIME: 4:11:48 PM
 FILE: p:\pwhdr\users\01\HDR\US_East_01\Documents\3322\10030389\6.0_CAD_BIM\6.2_Work_In_Progress\B-3186-B-5898_TrafficControl\TCP\B3186-B5898-TMP_41.dgn

REVISIONS

PROJ. REFERENCE NO.	SHEET NO.
B-3186 / B-5898	TMP-42

HDR
 HDR Engineering, Inc. of the Carolinas
 555 Fayetteville St, Suite 900 Raleigh, N.C. 27601
 N.C.B.E.L.S. License Number: F-0116

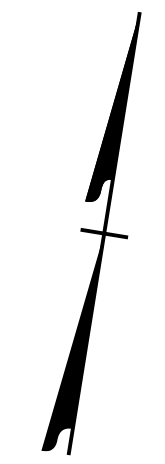

PLACE TEMPORARY MARKINGS IN THE FINAL PATTERN ON ALL ROADS
 (SEE FINAL MARKING PLANS)

-L LT- STA. 15+00 +/-
 -L RT- STA. 15+00 +/-
 BEGIN MEDIAN CONSTRUCTION

REMOVE MEDIAN Crossovers AND COMPLETE ANY REMAINING SHOULDER WORK

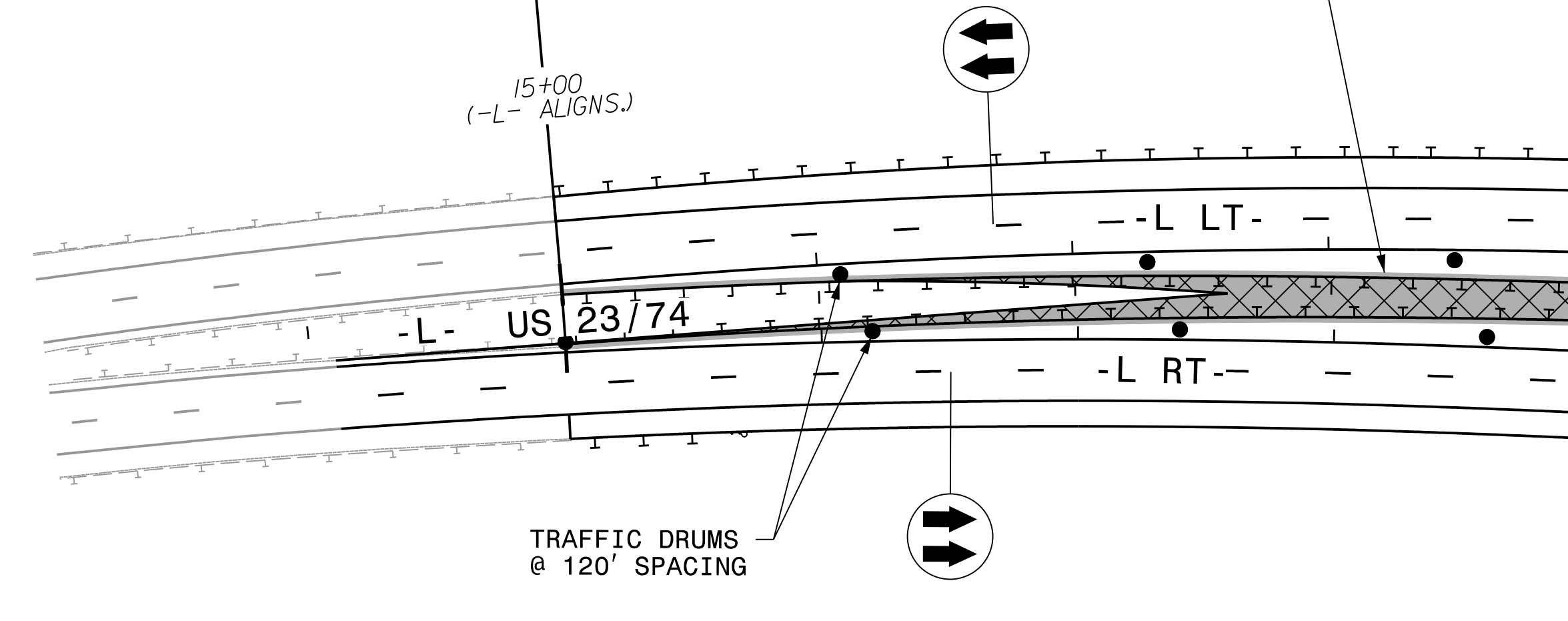

PROTECT APPROACH ENDS OF MEDIAN GUARDRAIL UNTIL FINAL GUARDRAIL IS INSTALLED

REVISTIONS

PLOT DRIVER: NCDOT_pdf_color_eng_50.plt
 USER: CHARNDEN
 FILE: p:\p\p\h\p\users\01\h\p\US_East_01\Documents\3322\10030389\6.0_CAD_BIM\6.2_Work_In_Progress\B-3186-B-5898_TrafficControl\TCP\B3186-B5898-TMP_TMP-42.dgn
 DATE: 1/21/2022
 TIME: 4:12:08 PM

APPROVED: *Michael T. Rzepka*

DATE: 3/17/2022

SEAL

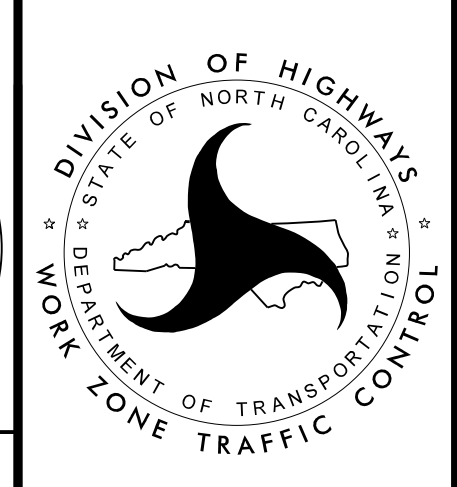

PHASE 4, STEP 1

DOCUMENT NOT CONSIDERED FINAL
 UNLESS ALL SIGNATURES COMPLETED

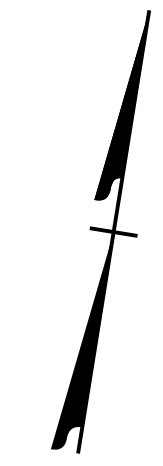
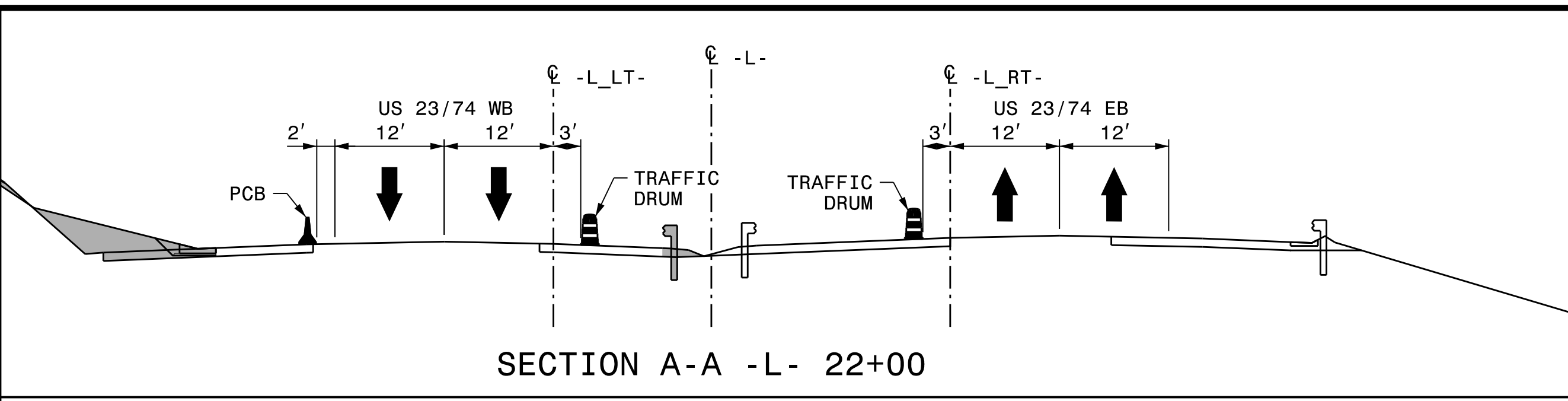

PLACE TEMPORARY MARKINGS IN THE FINAL PATTERN ON ALL ROADS (SEE FINAL MARKING PLANS)

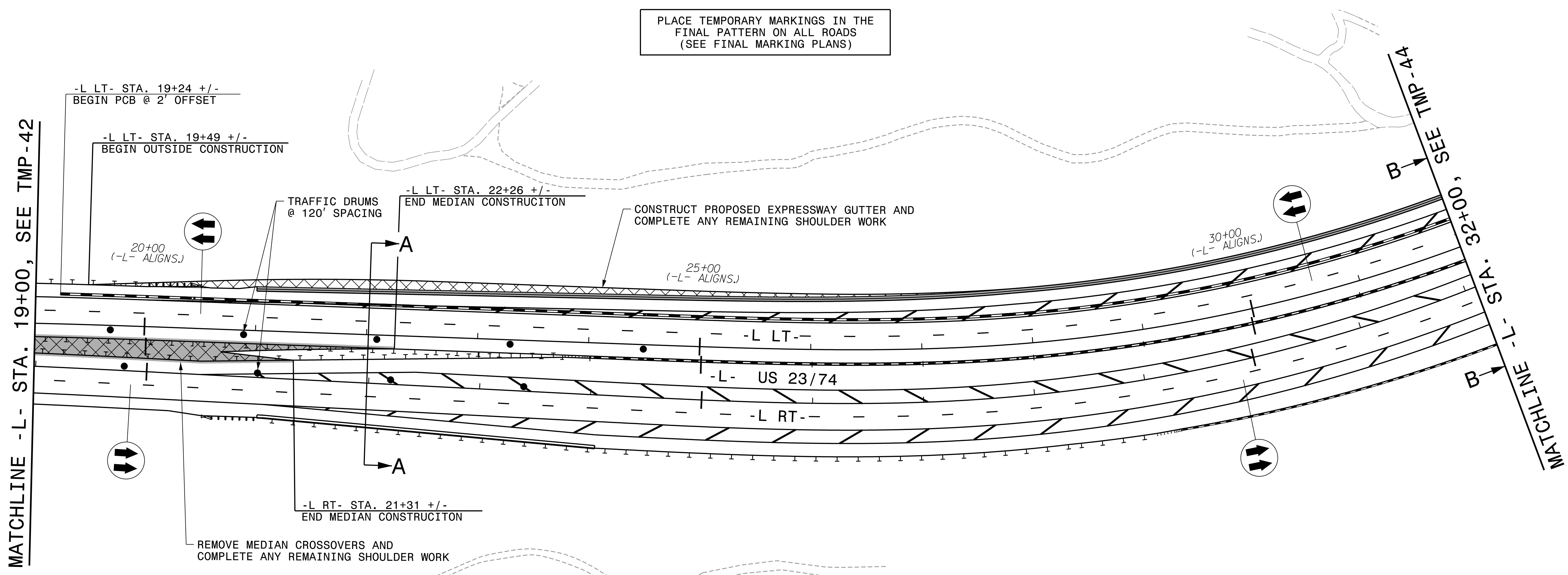

PROTECT APPROACH ENDS OF MEDIAN GUARDRAIL UNTIL FINAL GUARDRAIL IS INSTALLED

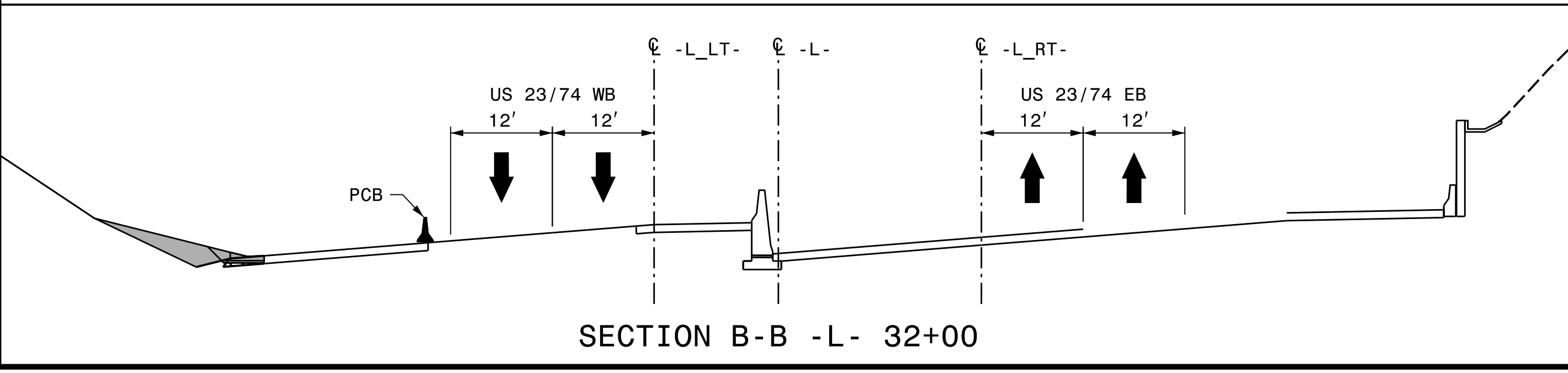

APPROVED: *Michael T. Rzepka*

DATE: 3/17/2022

SEAL

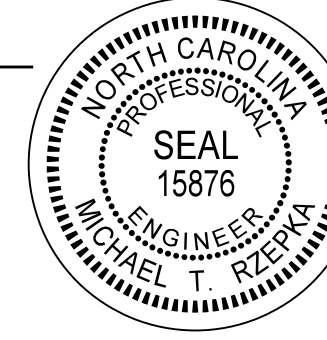

DOCUMENT NOT CONSIDERED FINAL UNLESS ALL SIGNATURES COMPLETED

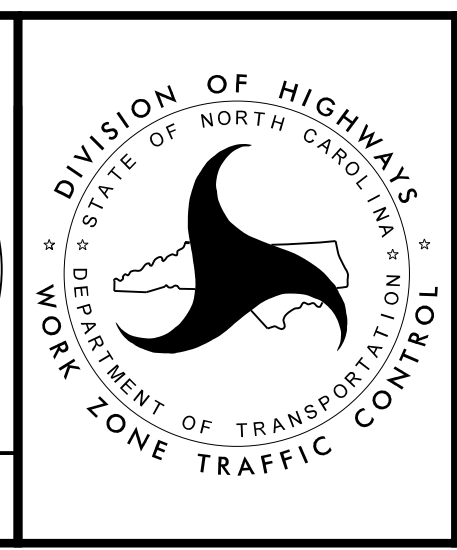

PHASE 4, STEP 1

PLOT DRIVER: NCDOT_pdf_color_eng_50.pit
 USER: CHARNDEN
 DATE: 1/21/2022
 TIME: 4:12:30 PM
 FILE: p:\p\hndr\users\01\hdr\US_East_01\Documents\3322\10030389\6.0_CAD_BIM\6.2_Work_In_Progress\B-3186-B-5898_TrafficControl\CP\B3186-B5898-TMP_TMP43.dgn

REVISIONS

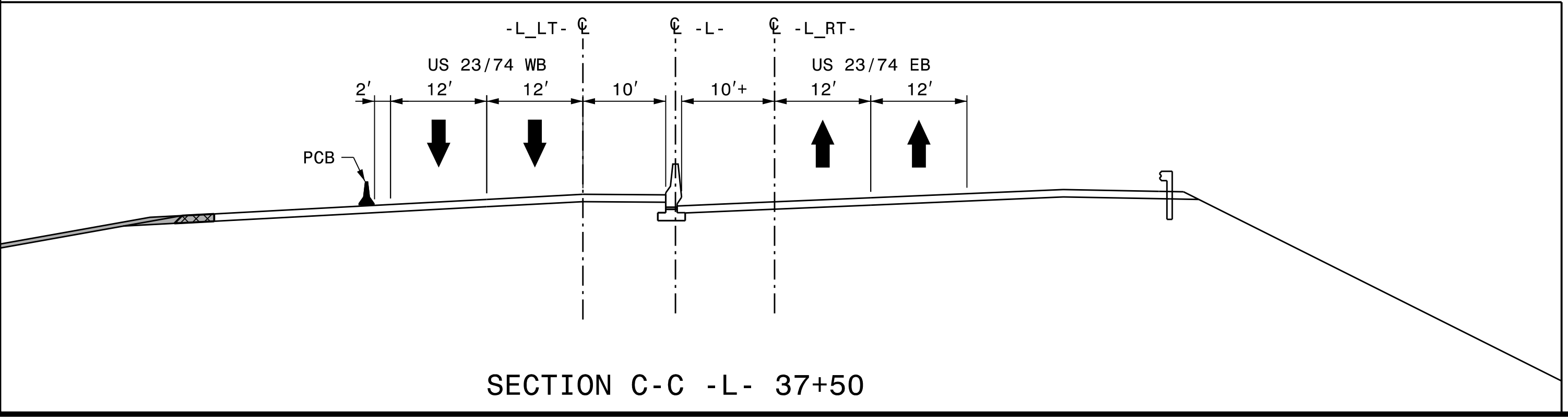
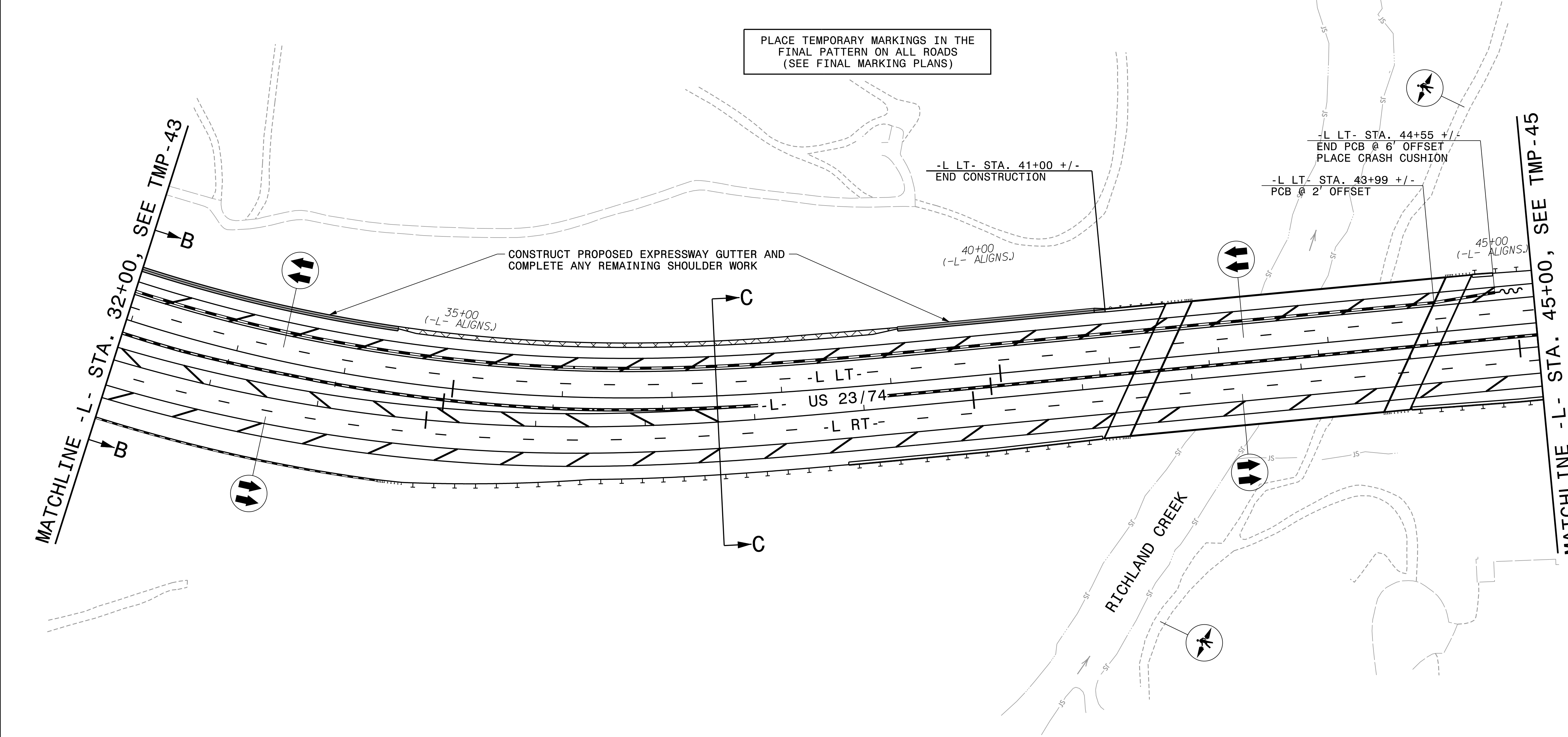
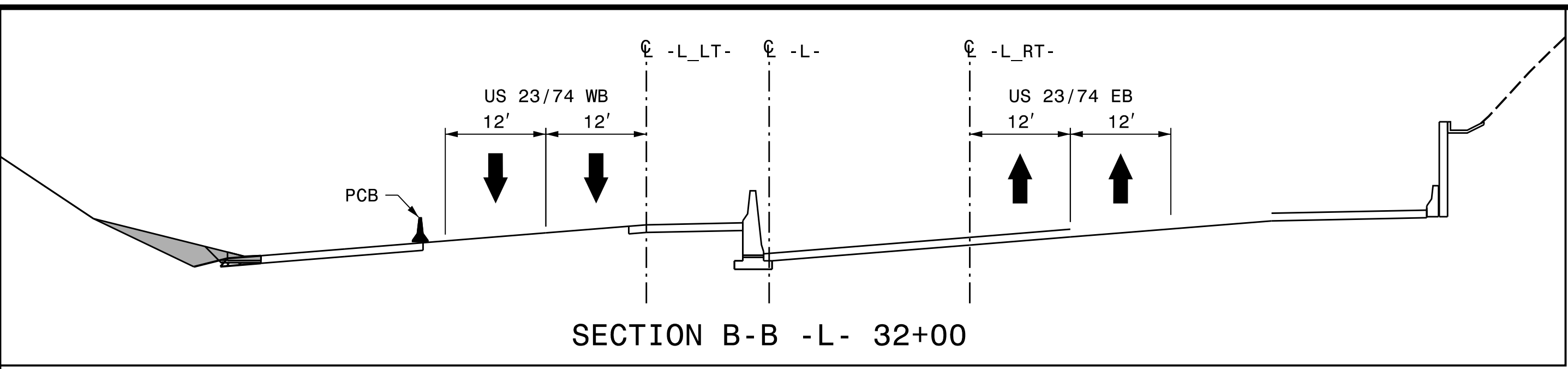

PLACE TEMPORARY MARKINGS IN THE FINAL PATTERN ON ALL ROADS (SEE FINAL MARKING PLANS)

-L LT- STA. 41+00 +/-
END CONSTRUCTION

-L LT- STA. 44+55 +/-
END PCB @ 6' OFFSET
PLACE CRASH CUSHION

-L LT- STA. 43+99 +/-
PCB @ 2' OFFSET

CONSTRUCT PROPOSED EXPRESSWAY GUTTER AND COMPLETE ANY REMAINING SHOULDER WORK

MATCHLINE -L- STA. 32+00, SEE TMP-43

MATCHLINE -L- STA. 45+00, SEE TMP-45

RICHLAND CREEK

REVISIONS

PLOT DRIVER: NCDOT_pdf_color_eng_50.pit
PENTABLE: NCDOT_tcp.tbl
USER: CHARNDEN
DATE: 1/21/2022
TIME: 4:12:51 PM
FILE: pw:\pwhdr\users\charnden\us_east\01\documents\3322\10030389\6.0\CAD_BIM\6.2_Work_In_Progress\B-3186-B-5898\Traffic\TrafficControl\TCP\B3186-B5898-TMP_TMP44.dgn

APPROVED: *Michael T. Rzepka*

DATE: 3/17/2022

SEAL

SEAL
15876
MICHAEL T. RZEPKA
ENGINEER



PHASE 4, STEP 1

DOCUMENT NOT CONSIDERED FINAL UNLESS ALL SIGNATURES COMPLETED

PLACE TEMPORARY MARKINGS IN THE FINAL PATTERN ON ALL ROADS (SEE FINAL MARKING PLANS)

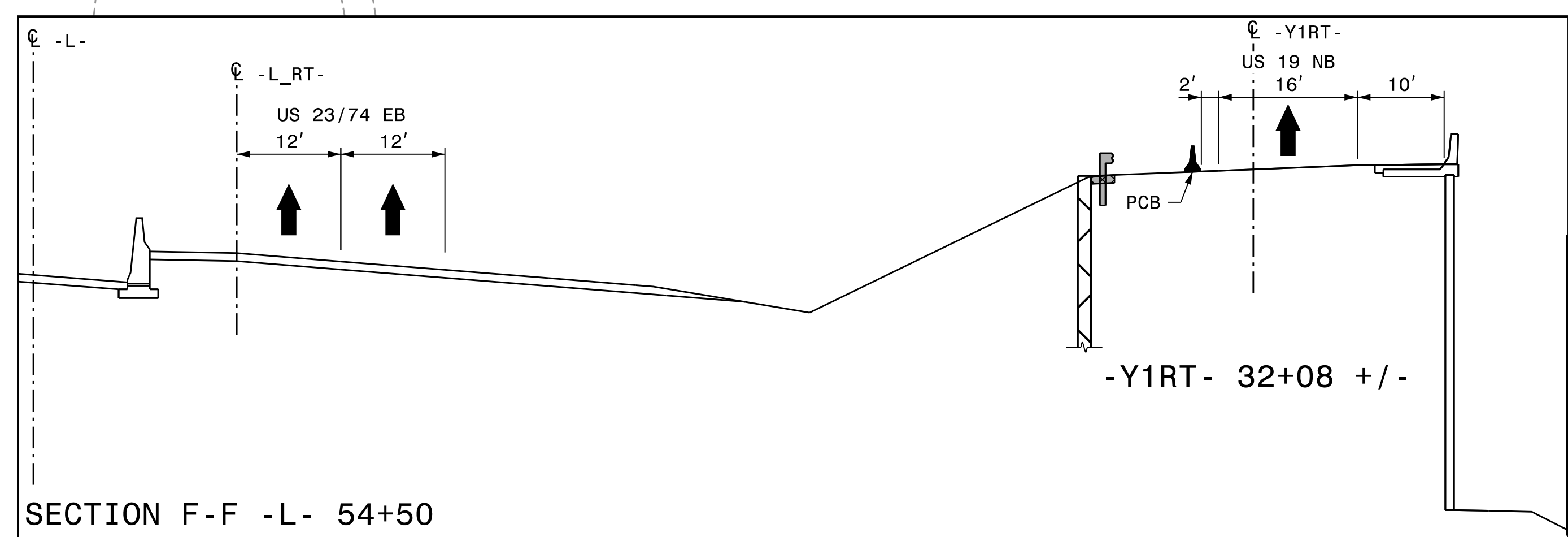
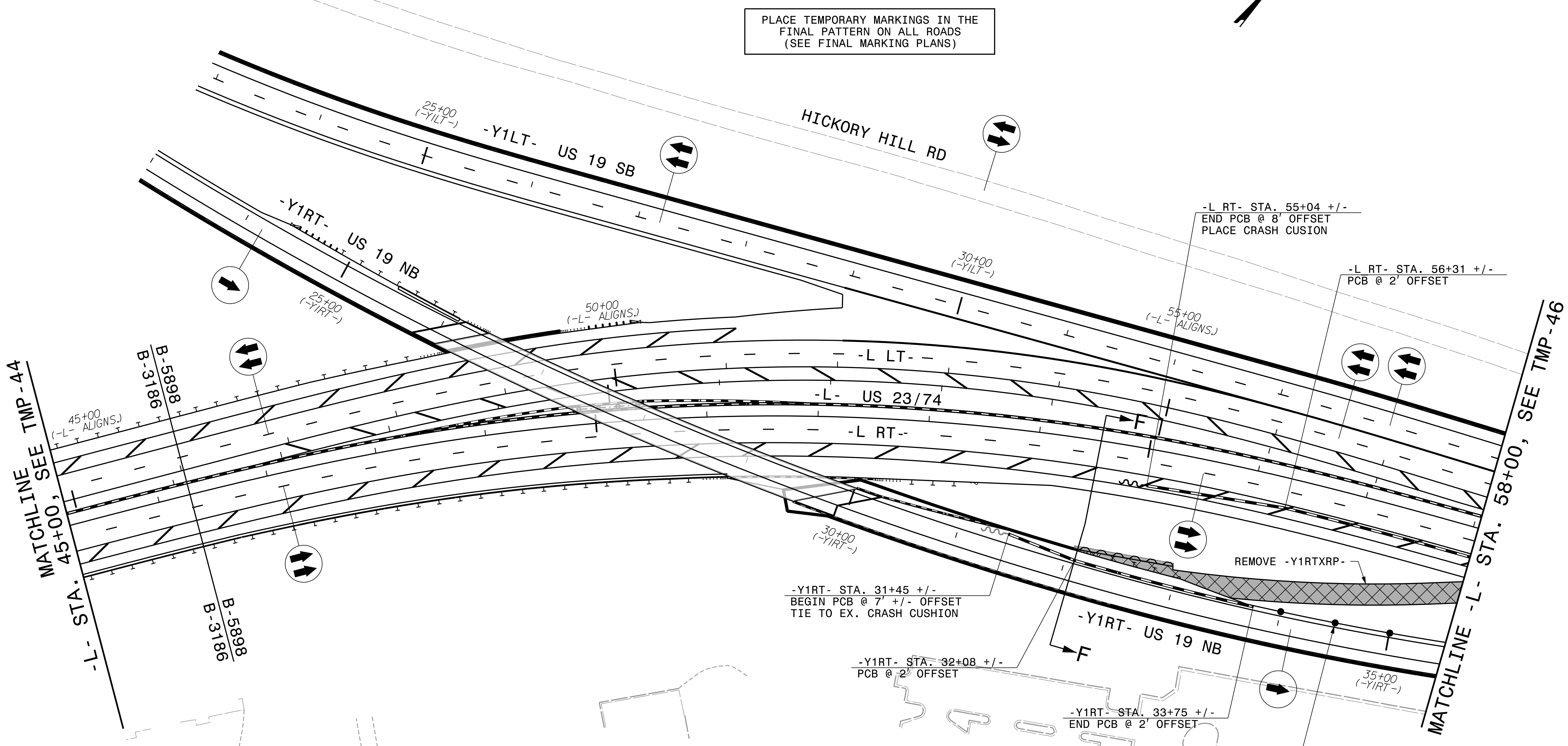
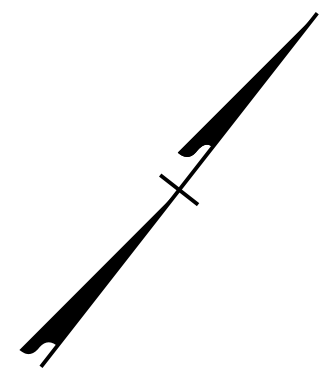

APPROVED: *Michael T. Rzepka*
 DATE: 3/17/2022
 SEAL

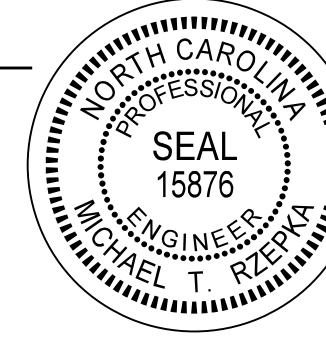

DOCUMENT NOT CONSIDERED FINAL UNLESS ALL SIGNATURES COMPLETED



PHASE 4, STEP 1

PLOT DRIVER: NCDOT_pdf_color_eng_50.plt
 USER: CHARNDEN
 DATE: 1/21/2022
 TIME: 4:13:12 PM
 FILE: p:\p\h\p\users\01\h\p\US_East_01\Documents\3322\10030389\6.0_CAD_BIM\6.2_Work_In_Progress\B-3186-B-5898_TrafficControl\TCP\B3186-B5898_TMP_TMP45.dgn

REVISIONS

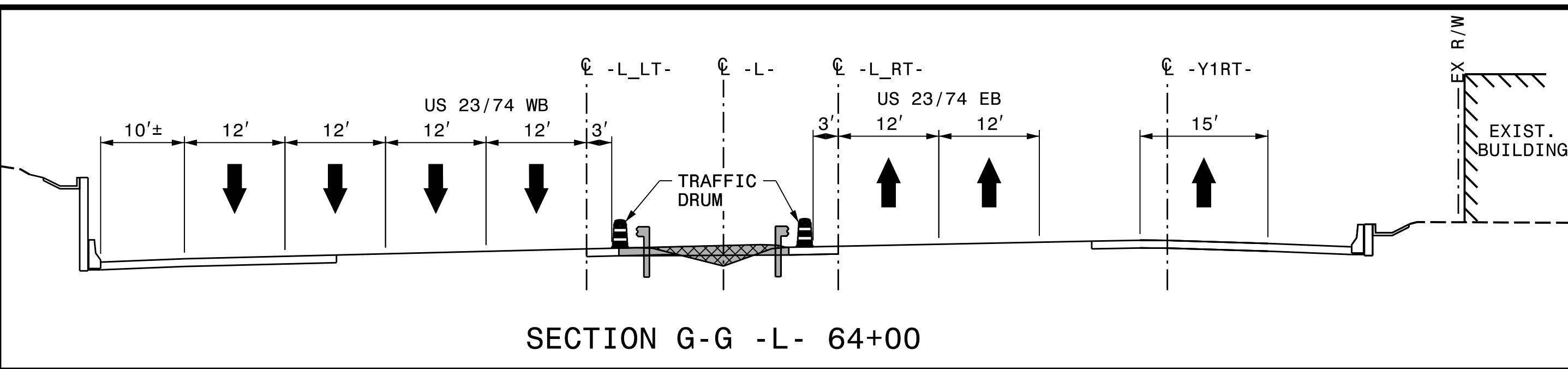

PLACE TEMPORARY MARKINGS IN THE FINAL PATTERN ON ALL ROADS (SEE FINAL MARKING PLANS)

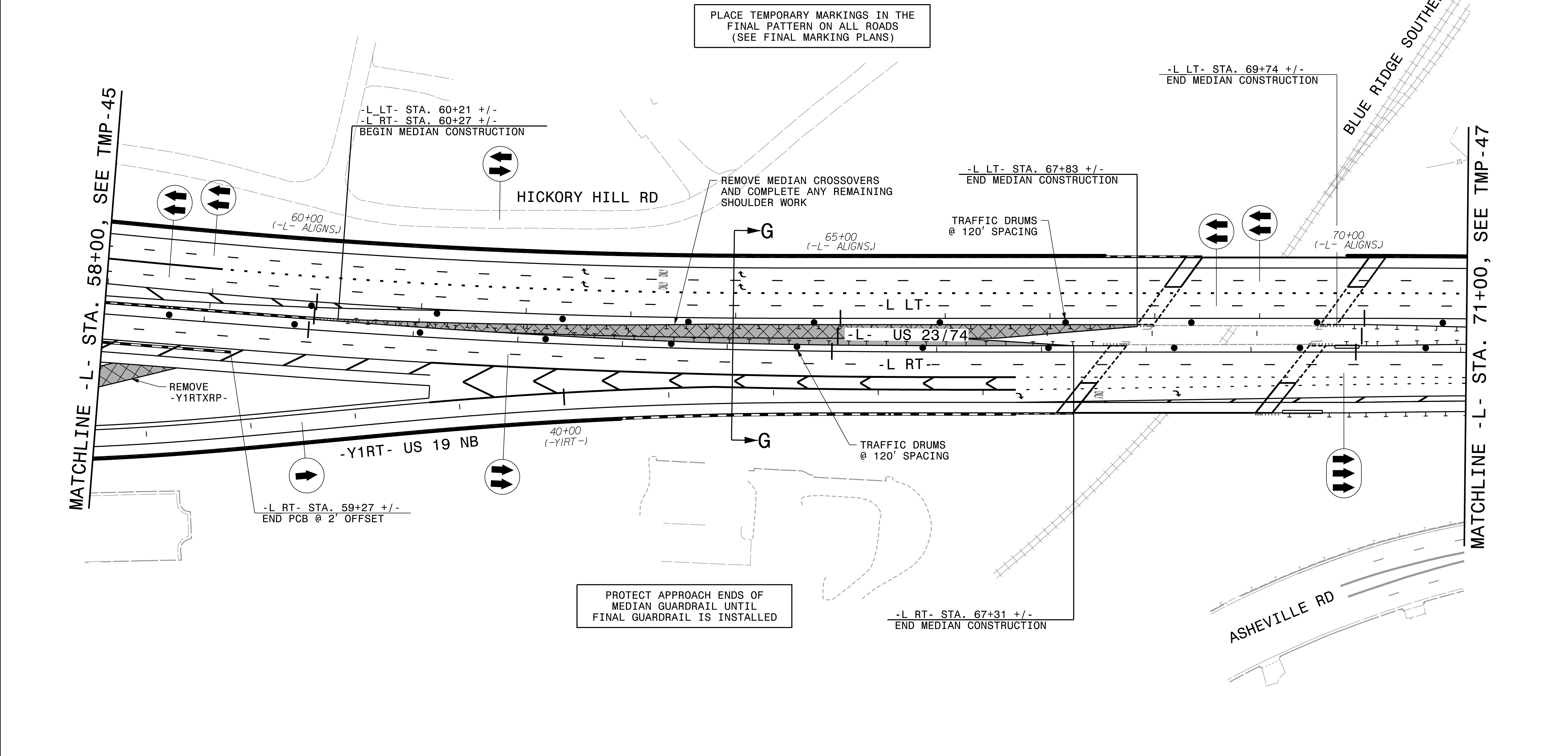
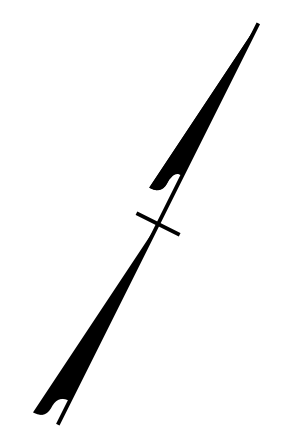

MATCHLINE -L- STA. 58+00, SEE TMP-45

MATCHLINE -L- STA. 71+00, SEE TMP-47

REVISIONS

PLOT DRIVER: NCDOT_pdf_color_eng_50.plt
 USER: CHARNDEN
 DATE: 1/21/2022
 TIME: 4:13:34 PM
 FILE: p:\pwhdr\users\charnd\US_East_01\Documents\3322\10030389\6.0_CAD_BIM\6.2_Work_In_Progress\B-3186-B-5898_TrafficControl\CP\B3186-B5898_TMP_TMP46.dgn

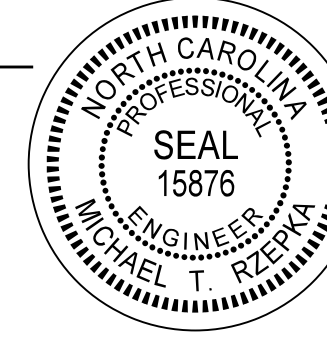
APPROVED: *Michael T. Rzepka*
 DATE: 3/17/2022
 SEAL

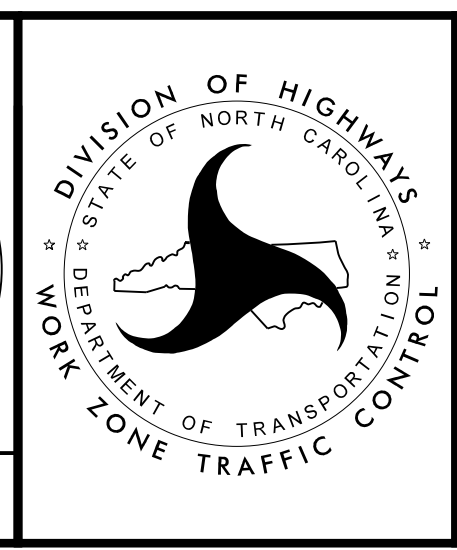

PHASE 4, STEP 1

DOCUMENT NOT CONSIDERED FINAL
UNLESS ALL SIGNATURES COMPLETED

PROJ. REFERENCE NO.	SHEET NO.
B-3186 / B-5898	TMP-47
 HDR Engineering, Inc. of the Carolinas 555 Fayetteville St., Suite 900 Raleigh, N.C. 27601 N.C.B.E.L.S. License Number: F-0116	

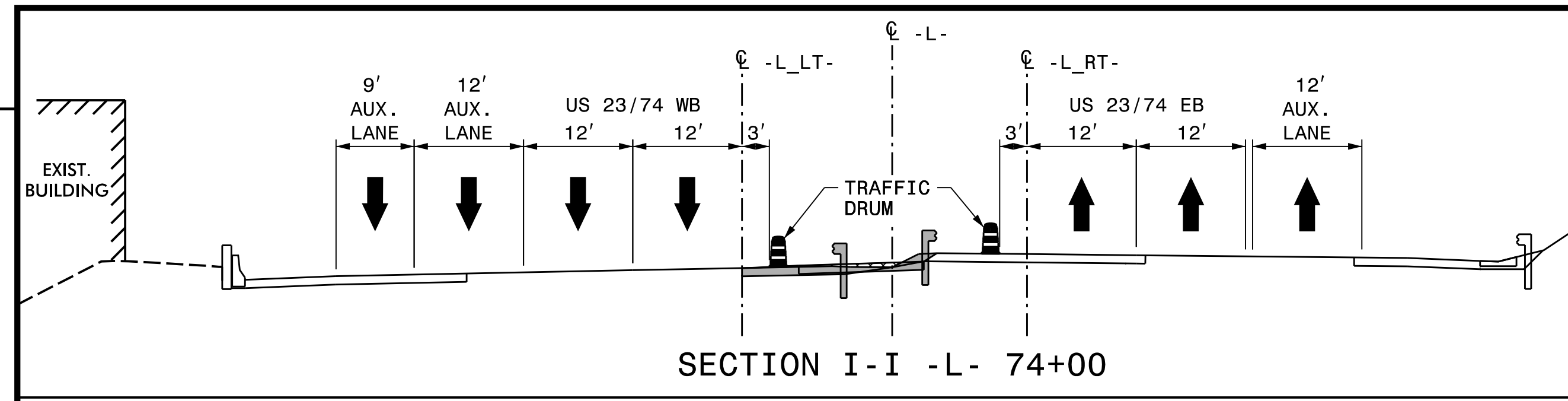

PLACE TEMPORARY MARKINGS IN THE FINAL PATTERN ON ALL ROADS (SEE FINAL MARKING PLANS)

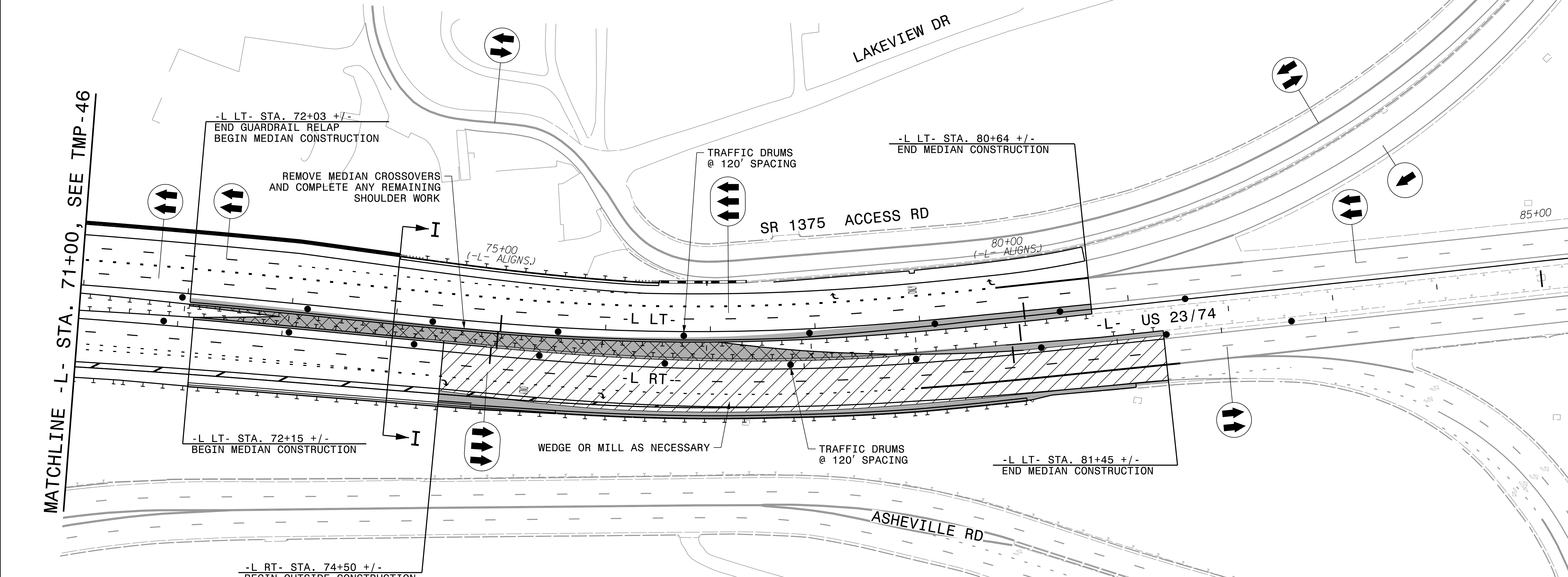
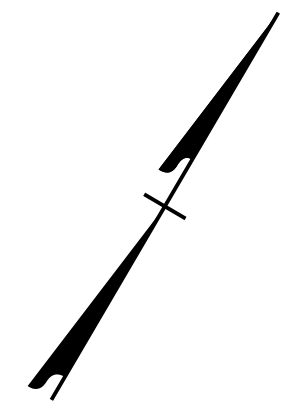

MATCHLINE -L- STA. 71+00, SEE TMP-46

PLOT DRIVER: NCDOT_pdf_color_eng_50.pit
 USER: CHARNDEN
 DATE: 1/21/2022
 TIME: 4:13:54 PM
 FILE: p:\p\pndr\users\01\HDR_US_East_01\Documents\3322\10030389\6.0_CAD_BIM\6.2_Work_In_Progress\B-3186-B-5898\TrafficControl\TCP\B3186-B5898-TMP_TMP47.dgn

REVISIONS

APPROVED: *Michael T. Rzepka*

DATE: 3/17/2022

SEAL

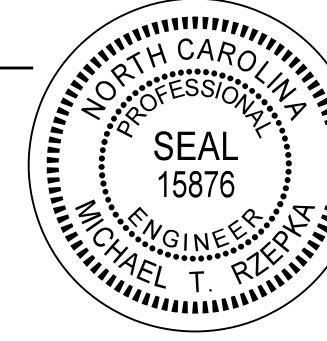

DOCUMENT NOT CONSIDERED FINAL UNLESS ALL SIGNATURES COMPLETED



PHASE 4, STEP 1