

SECTION A-A

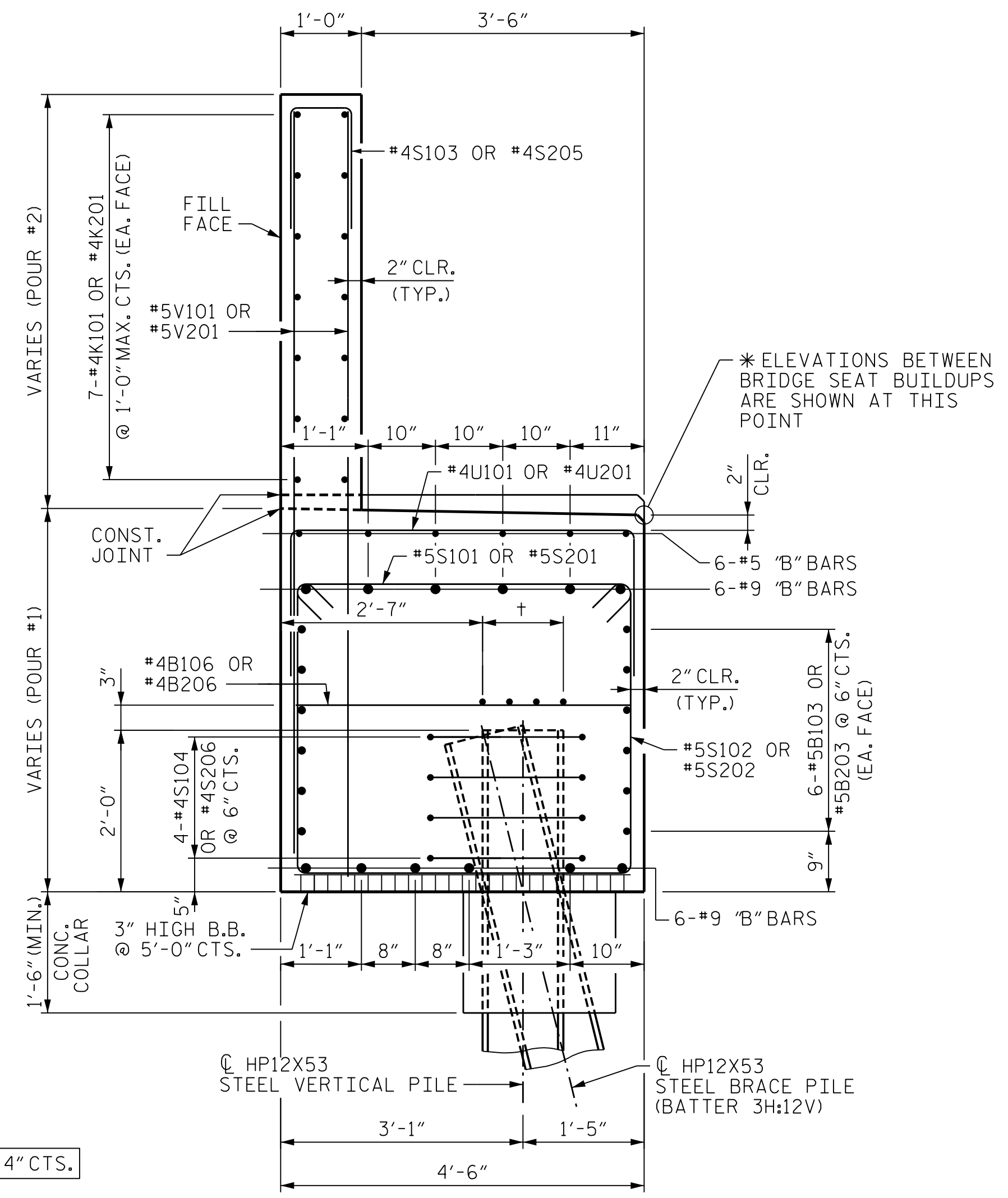

SECTION B-B

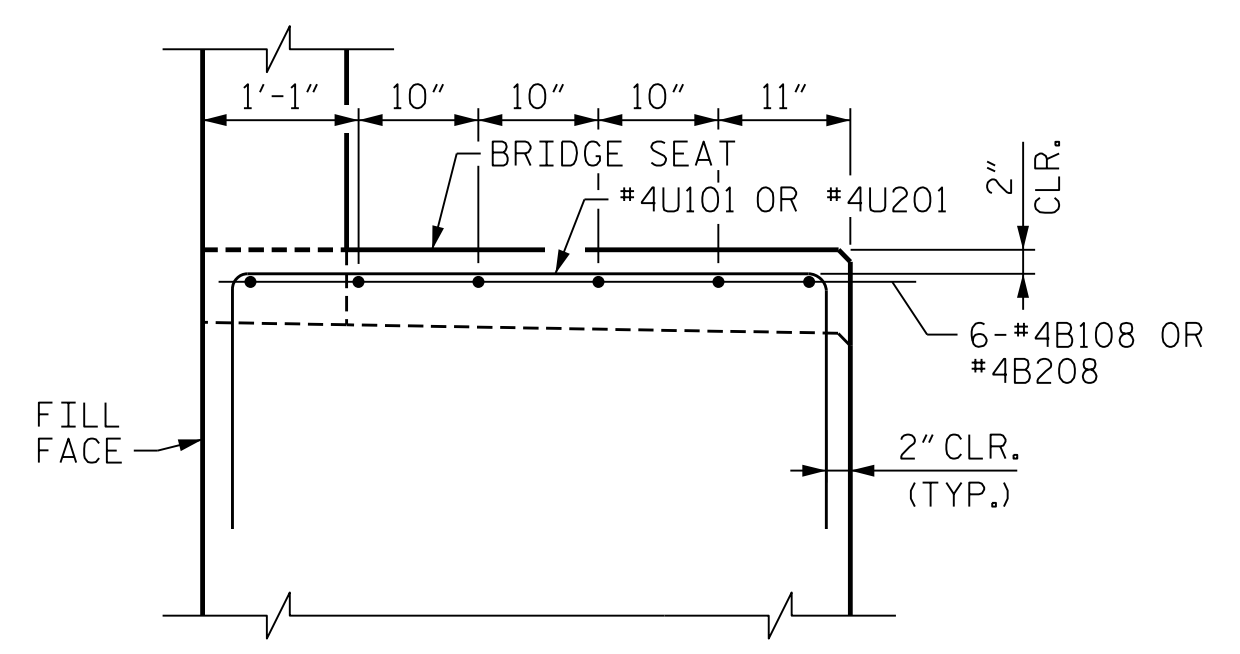

SECTION C-C

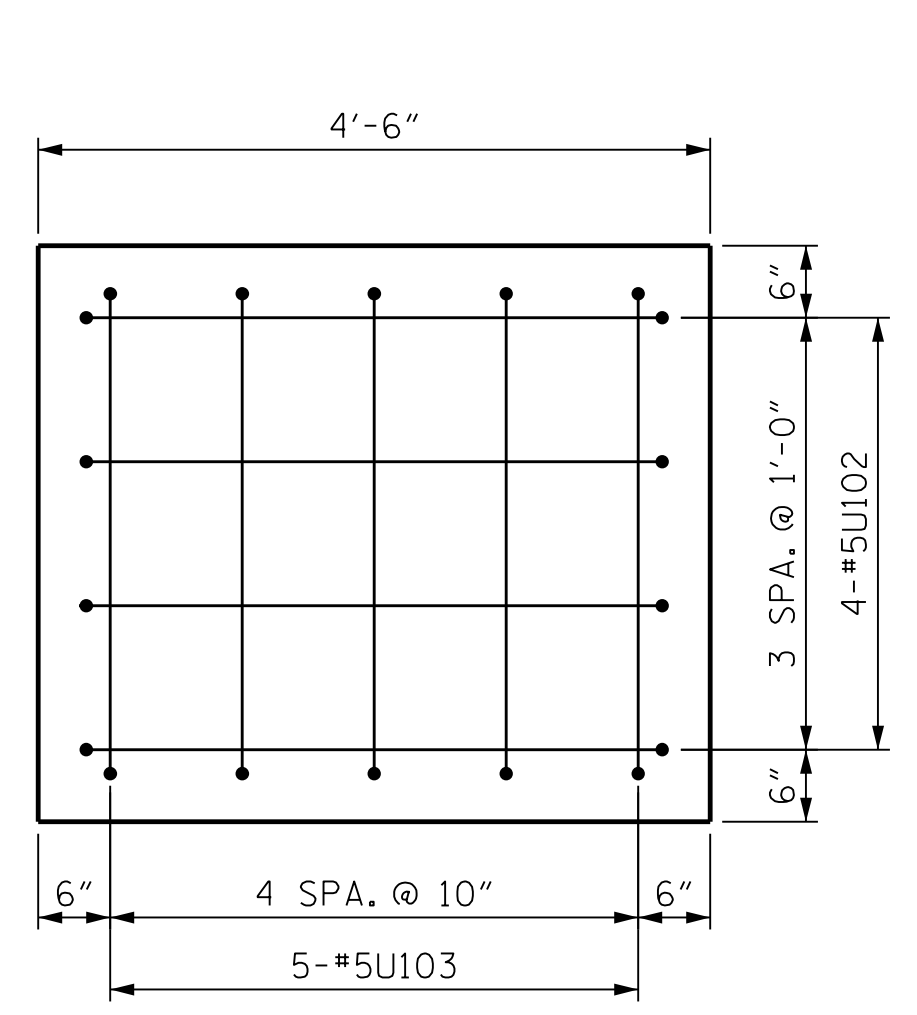

VIEW F-F

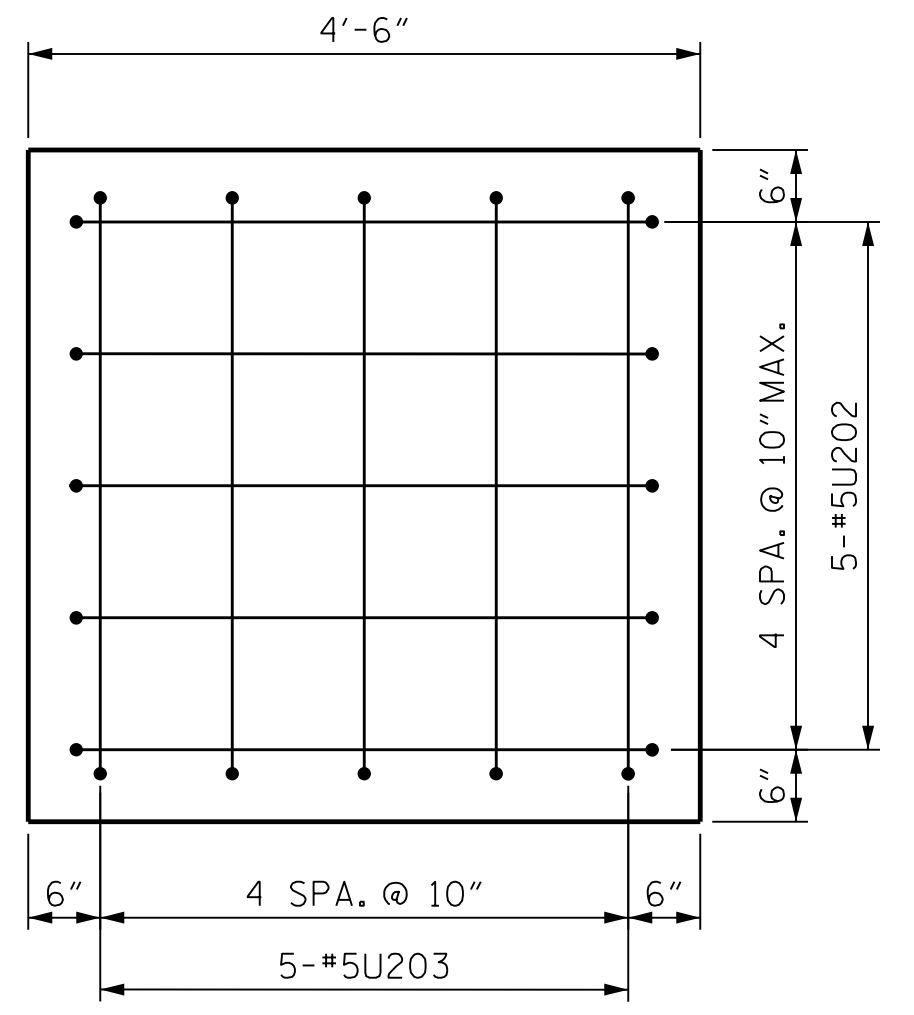

VIEW G-G

† = 4-#4B107 OR #4B207 @ 4" CTS.

PROJECT NO. B-3186/B-5898
HAYWOOD COUNTY
 STATION: 42+71.13 -L-
 SHEET 5 OF 6

STATE OF NORTH CAROLINA
 DEPARTMENT OF TRANSPORTATION
 RALEIGH

**SUBSTRUCTURE
 END BENT 2
 SECTION AND DETAILS**



1/25/2022

DES BY: <u>K. DICKENS</u>	DATE: <u>06/21</u>	DWG BY: <u>B. PETERSON</u>	DATE: <u>06/21</u>
DES CHK: <u>L. GUALTIERI</u>	DATE: <u>06/21</u>	CHK BY: <u>K. DICKENS</u>	DATE: <u>07/21</u>

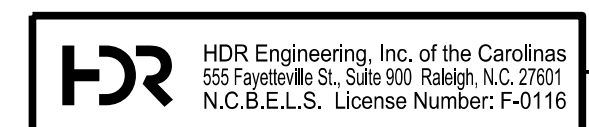

DOCUMENT NOT CONSIDERED FINAL
 UNLESS ALL SIGNATURES COMPLETED

REVISIONS					
NO.	BY:	DATE:	NO.	BY:	DATE:
1	--	--	3	--	--
2	--	--	4	--	--

SHEET NO. 501-52
 TOTAL SHEETS 59

PLOT DRIVER: NCDOT STRUCTURES DEFAULT PLOTTER.plt
 PENTABLE: NCDOT STRUCTURES DEFAULT PEN.tbl
 USER: PPETERSO
 DATE: 1/25/2022
 TIME: 8:34:22 AM
 FILE: ... \401.255.B5898B3186.SMU.E2.052_430168.dgn