

PARTIAL PLAN

SHEAR KEY DETAIL

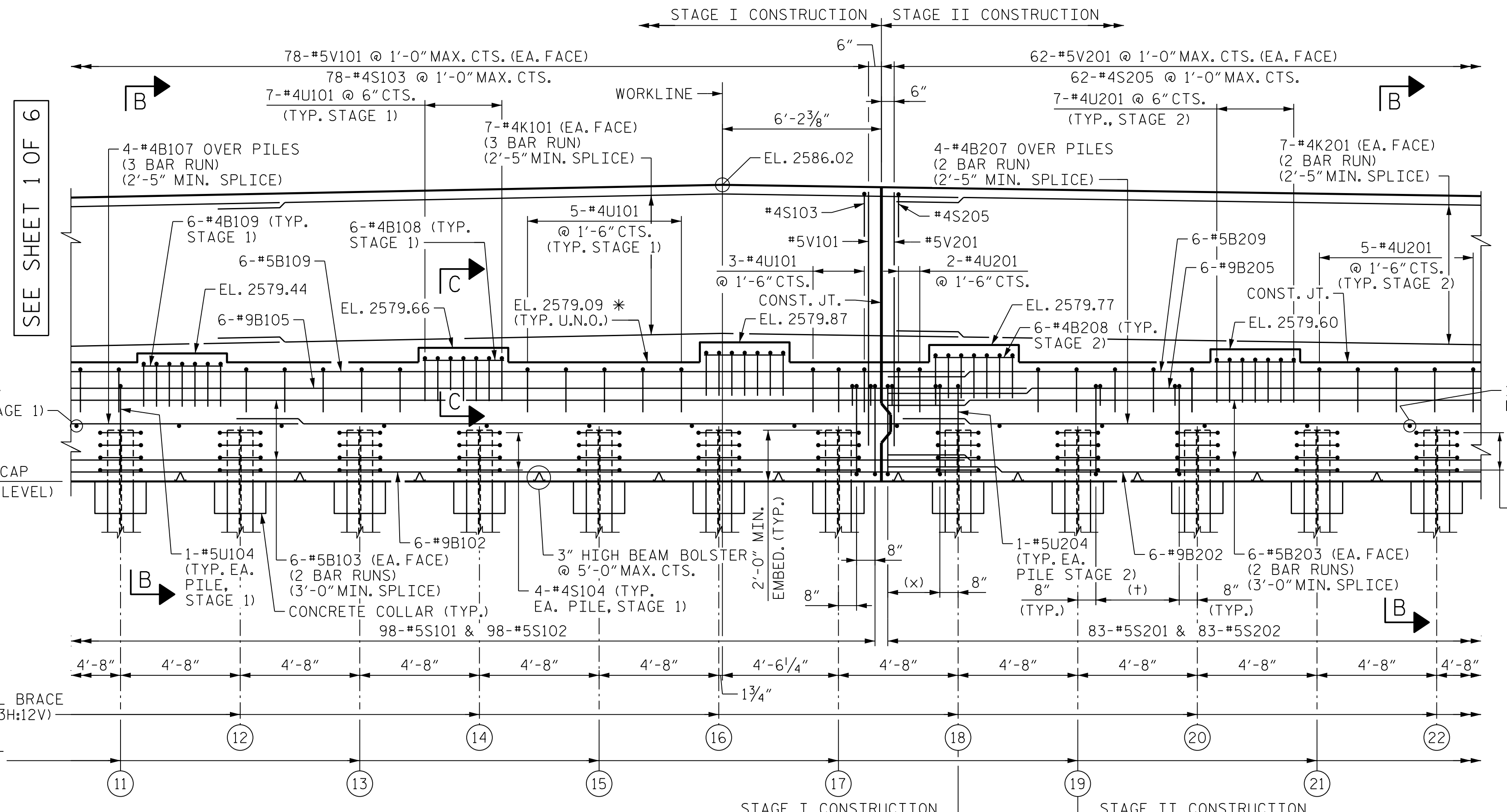
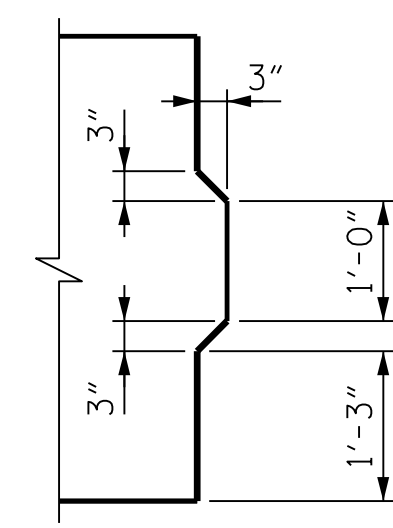

PARTIAL ELEVATION

SEE SHEET 3 OF 6

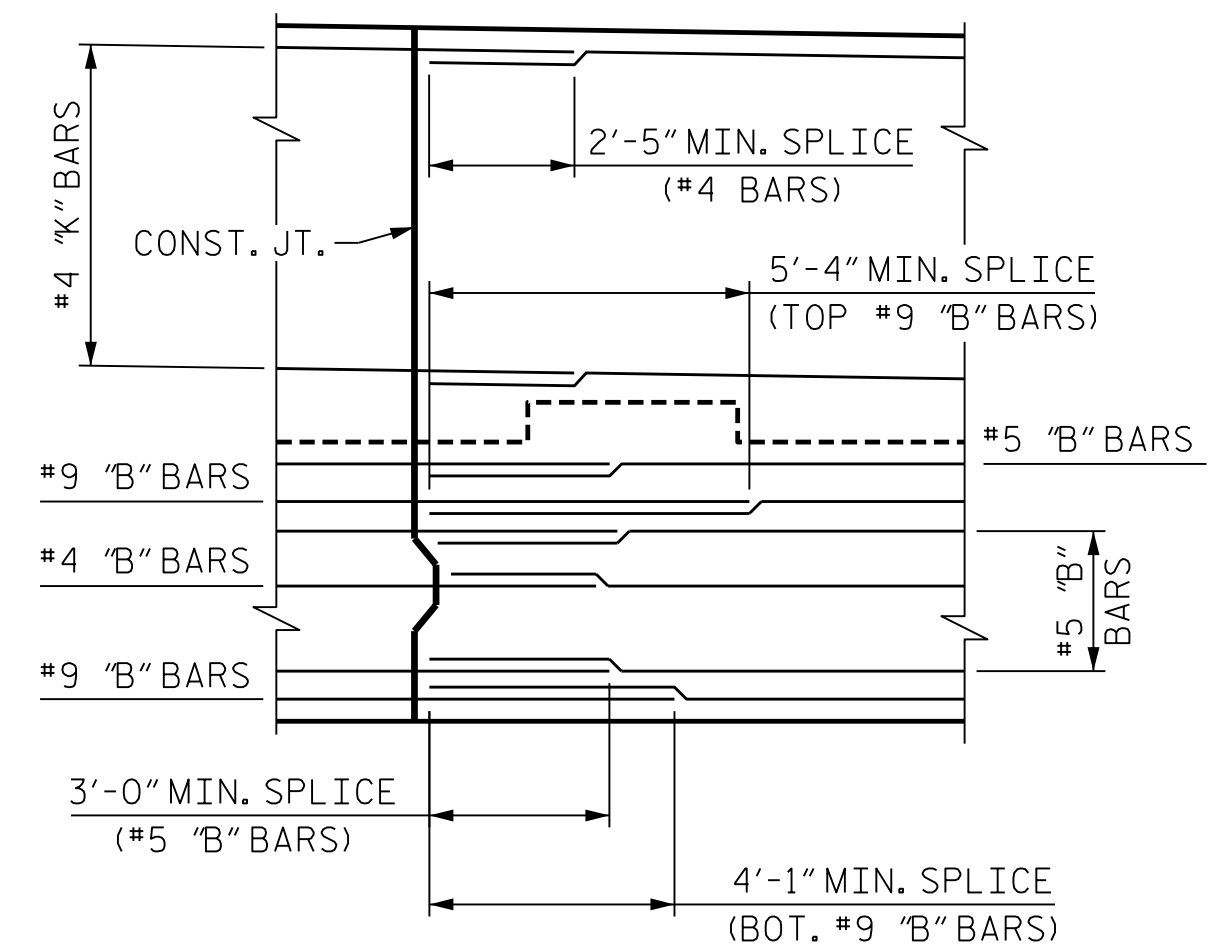

SPLICE DETAIL

PROJECT NO. B-3186/B-5898
HAYWOOD COUNTY
 STATION: 42+71.13 -L-

SHEET 2 OF 6

STATE OF NORTH CAROLINA
 DEPARTMENT OF TRANSPORTATION
 RALEIGH

**SUBSTRUCTURE
 END BENT 2
 PLAN AND ELEVATION
 STAGES 1 & 2**



1/25/2022

| REVISIONS | | | | | |
|-----------|-----|-------|-----|-----|-------|
| NO. | BY: | DATE: | NO. | BY: | DATE: |
| 1 | -- | -- | 3 | -- | -- |
| 2 | -- | -- | 4 | -- | -- |

SHEET NO. 501-49
 TOTAL SHEETS 59



DOCUMENT NOT CONSIDERED FINAL
 UNLESS ALL SIGNATURES COMPLETED

PLOT DRIVER: NCDOT STRUCTURES DEFAULT PLOTTER.PHT
 USER: PETERSON DATE: 1/25/2022 TIME: 8:33:55 AM
 FILE: ... \401_240_B5898B3186_SMU_E2_049_430168.dgn

DES BY: K. DICKENS DATE: 06/21 DWG BY: B. PETERSON DATE: 06/21
 DES CHK: L. GUALTIERI DATE: 06/21 CHK BY: K. DICKENS DATE: 07/21

* FOR LOCATION OF ELEVATION BETWEEN BRIDGE
 SEAT BUILDUP, SEE "SUBSTRUCTURE END BENT 2
 SECTIONS AND DETAILS" SHEET 5 OF 6.