

**NOTES**  
 FOR END ELEVATION AND SECTION VIEWS SEE SHEET 3 OF 4.  
 STIRRUPS AND "U" BARS IN CAP MAY BE SHIFTED SLIGHTLY AS NECESSARY TO CLEAR ANCHOR BOLTS.  
 THE CONTRACTOR'S ATTENTION IS CALLED TO THE FACT THAT THE LONGITUDINAL REINFORCEMENT FOR THE DRILLED PIERS IS DETAILED WITH 3 FEET OF EXTRA LENGTH.  
 ALL STEEL IN THE DRILLED PIERS IS INCLUDED IN THE PAY ITEMS FOR "REINFORCING STEEL" AND "SPIRAL COLUMN REINFORCING STEEL" OR "EPOXY COATED SPIRAL COLUMN REINFORCING STEEL".  
 THE LOCATION OF THE CONSTRUCTION JOINT IN THE DRILLED PIERS IS BASED ON AN APPROXIMATE GROUND LINE ELEVATION. IF THE CONSTRUCTION JOINT IS ABOVE THE ACTUAL GROUND ELEVATION, THE CONTRACTOR SHALL PLACE THE CONSTRUCTION JOINT 1 FOOT BELOW THE GROUND LINE.

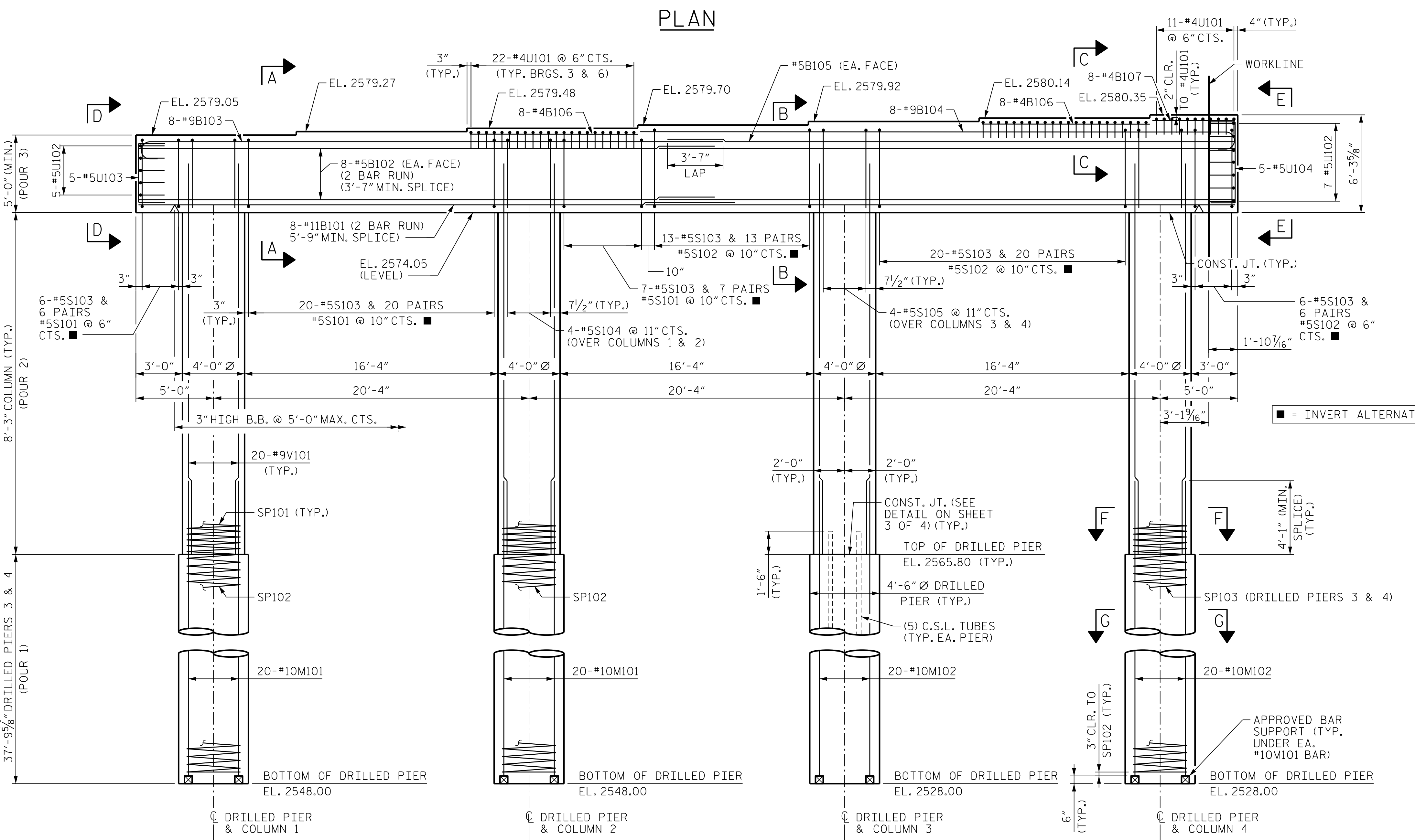
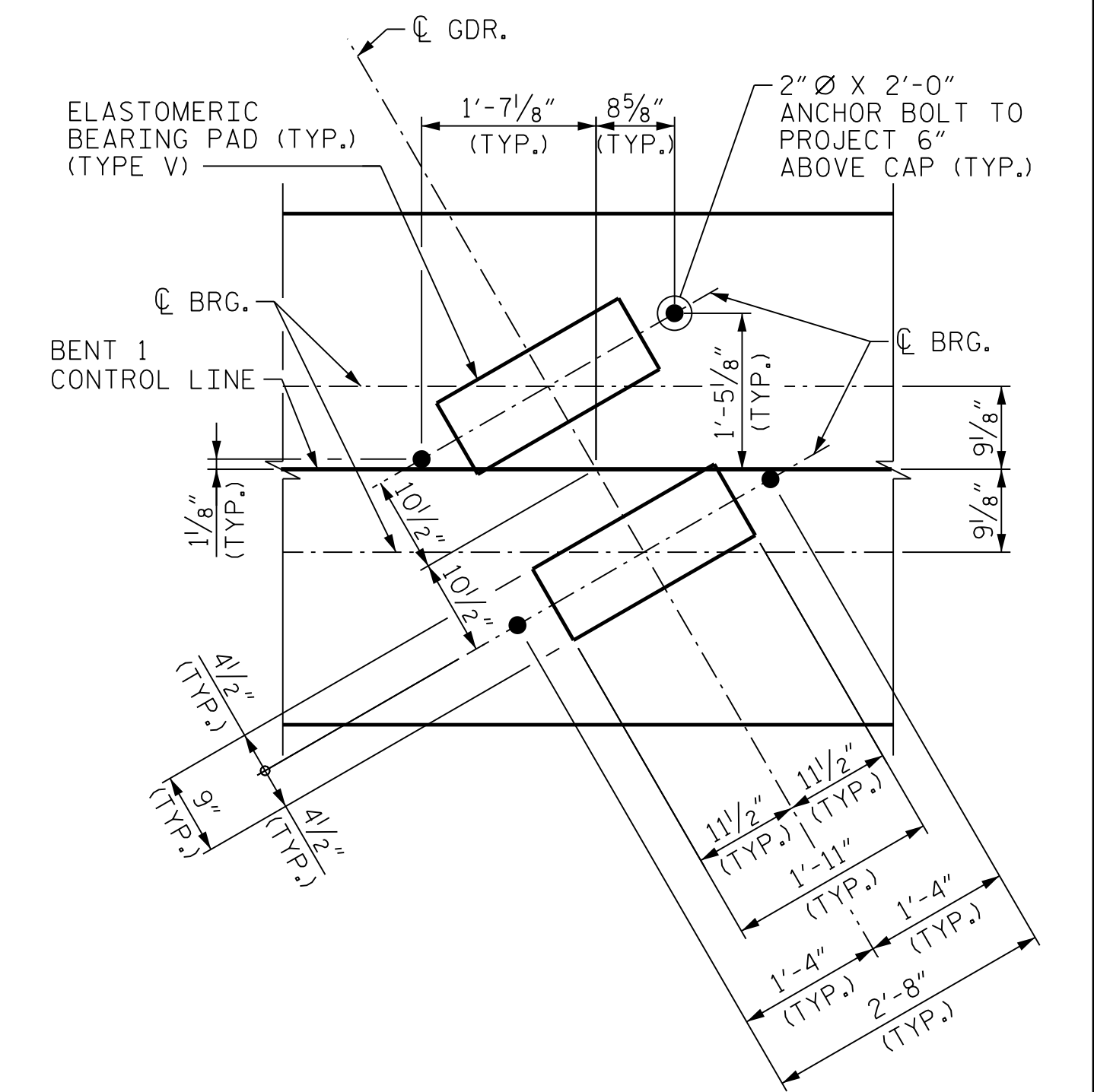
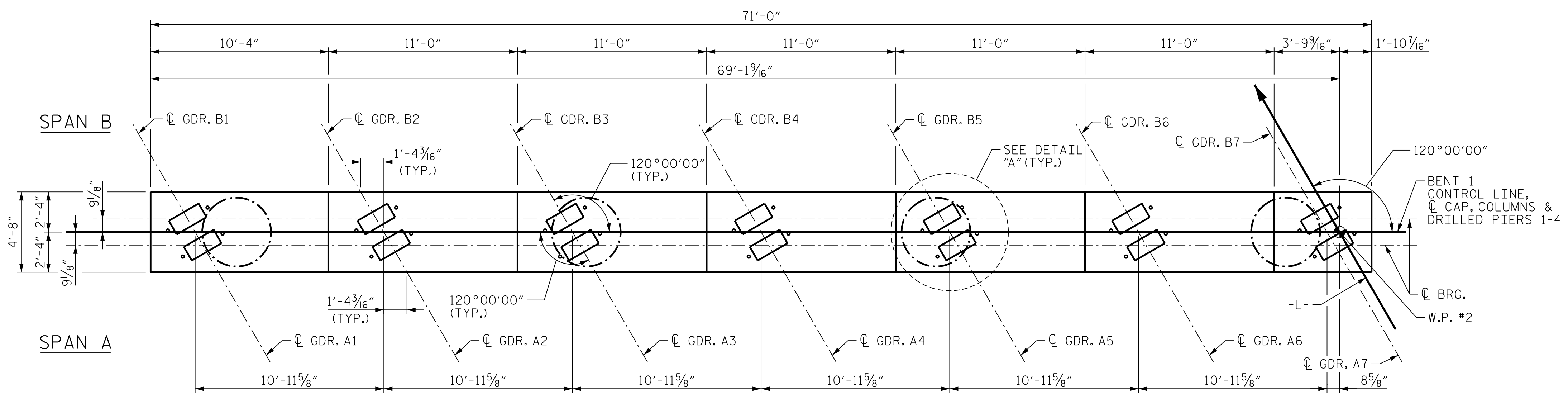

**ELEVATION**

**DETAIL "A"**

PROJECT NO. B-3186/B-5898  
 HAYWOOD COUNTY  
 STATION: 42+71.13 -L-

SHEET 1 OF 4  
 DEPARTMENT OF TRANSPORTATION  
 RALEIGH  
**SUBSTRUCTURE  
 BENT 1  
 PLAN AND ELEVATION  
 STAGE 1**



REVISIONS						SHEET NO.
NO.	BY:	DATE:	NO.	BY:	DATE:	SHEET NO.
1	--	--	3	--	--	TOTAL SHEETS
2	--	--	4	--	--	59

PLOT DRIVER: NCDOT STRUCTURES DEFAULT PLOTTER.plt PENTABLE: NCDOT STRUCTURES DEFAULT PEN.tbl  
 USER: PPRET0 DATE: 1/25/2022 TIME: 8:33:01 AM  
 FILE: ... \401\_215\_B5898B3186\_SMU.B1\_044\_430168.dgn

DES BY: L. GUALTIERI DATE: 06/21  
 DES CHK: K. DICKENS DATE: 06/21  
 DWG BY: D. CARTER DATE: 06/21  
 CHK BY: K. DICKENS DATE: 07/21

**HDR** HDR Engineering, Inc. of the Carolinas  
 555 Fayetteville St., Suite 900 Raleigh, N.C. 27601  
 N.C.B.E.L.S. License Number: F-0116

1/25/2022  
 DOCUMENT NOT CONSIDERED FINAL  
 UNLESS ALL SIGNATURES COMPLETED