

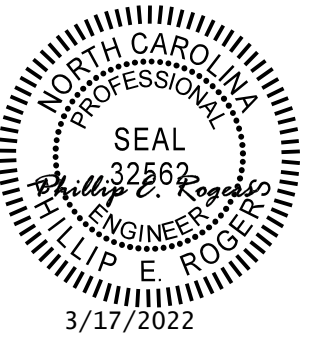

6/2/2022

SITE ② STRUCTURE TYPICAL SECTIONS

PROJECT REFERENCE NO. B-3186B-5898	SHEET NO. 2A-11
ROADWAY DESIGN ENGINEER 	PAVEMENT DESIGN ENGINEER
DOCUMENT NOT CONSIDERED FINAL UNLESS ALL SIGNATURES COMPLETED	
 HDR Engineering, Inc. of the Carolinas 555 Fayetteville St, Suite 900 Raleigh, N.C. 27601 N.C.B.E.L.S. License Number: F-0116	

BRIDGE AT -Y1RT- (US 19 EB) STATION 27+54.43
OVER -L- STATION 49+91.10

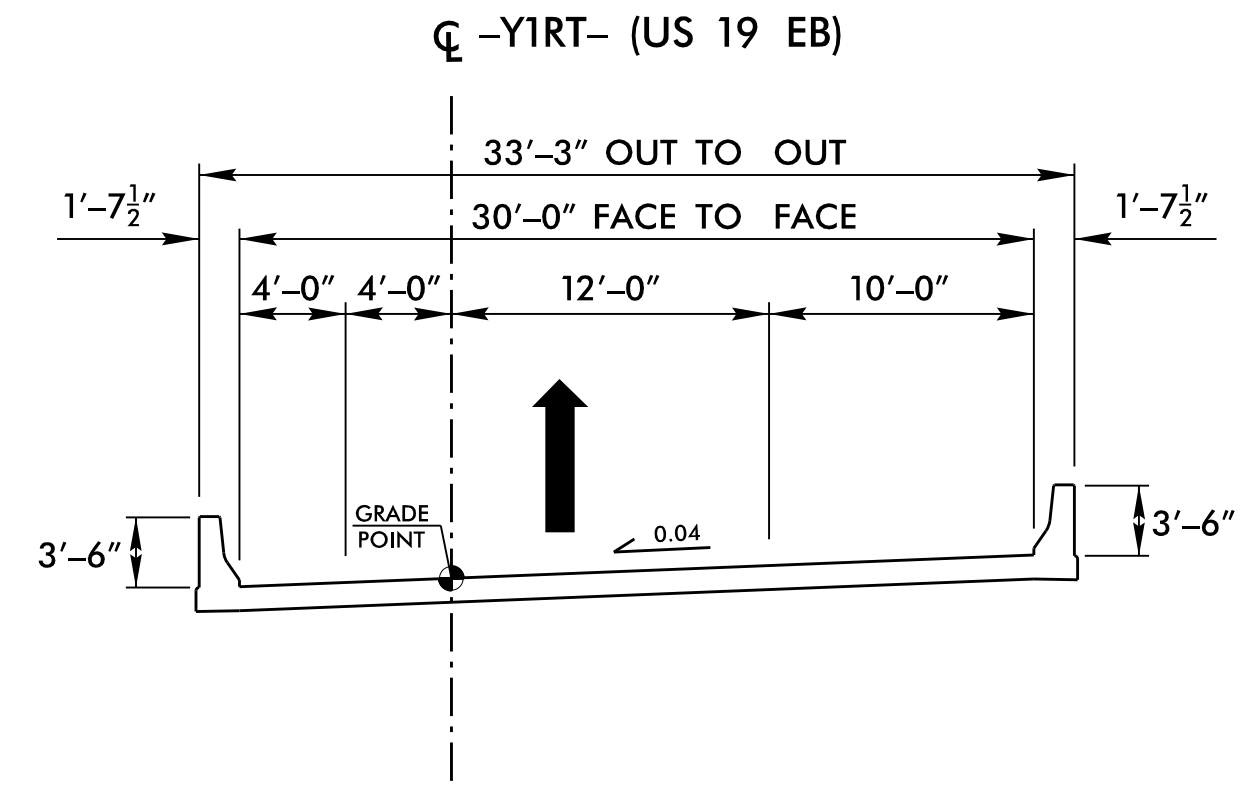

STRUCTURE TYPICAL SECTION

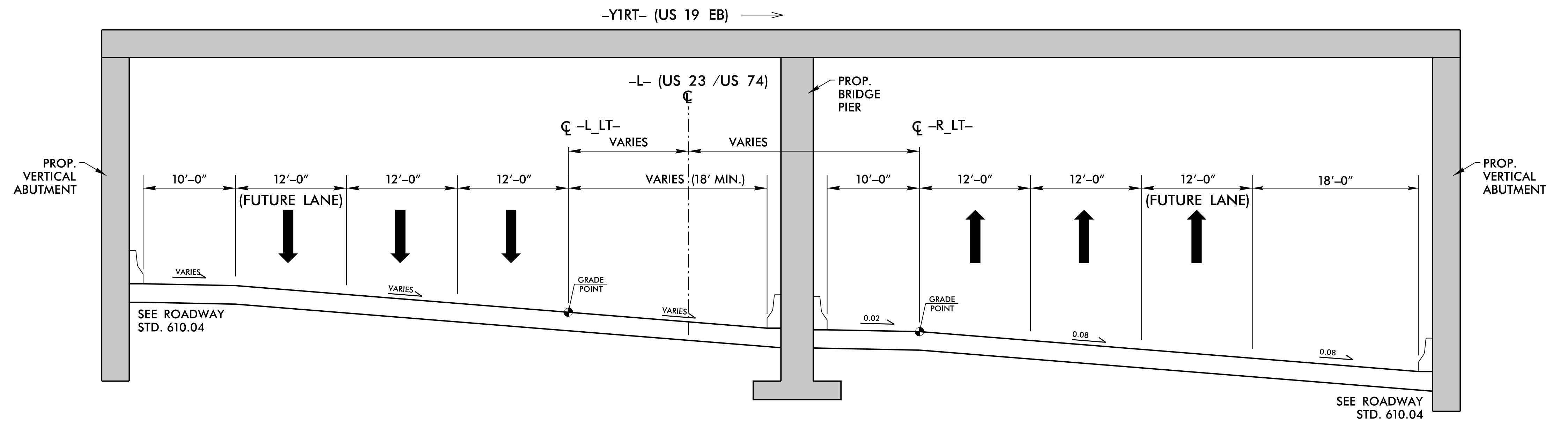

TYPICAL SECTION ON ROADWAY UNDER STRUCTURE

PLOT DRIVER: NCDOT.pdf_color_eng-50.plt
USER: HBAFE
FILE: \

DATE: 1/13/2022

TIME: 6:55:36 AM

PENTABLE: B-3186 B-5898 NCDOT_pshp.flr.tbl