

NOTES

ALL PRESTRESSING STRANDS SHALL BE 7-WIRE LOW-RELAXATION GRADE 270 STRANDS AND SHALL CONFORM TO AASHTO M203 EXCEPT FOR SAMPLING REQUIREMENTS WHICH SHALL BE IN ACCORDANCE WITH THE STANDARD SPECIFICATIONS.

ALL REINFORCING STEEL SHALL BE GRADE 60.

APPLY EPOXY PROTECTIVE COATING TO END OF GIRDER SURFACES INDICATED IN ELEVATION VIEW.

EMBEDDED PLATE "B-1" SHALL BE GALVANIZED IN ACCORDANCE WITH THE STANDARD SPECIFICATIONS.

ANCHOR STUDS SHALL CONFORM TO AASHTO M169 GRADES 1010 THROUGH 1020 OR APPROVED EQUAL, AND SHALL MEET THE TYPE "B" REQUIREMENTS OF SUBSECTION 7.3 OF THE ANSI/AASHTO/AWS D1.5 BRIDGE WELDING CODE.

AT ENDS OF GIRDERS TO BE EMBEDDED IN CONCRETE DIAPHRAGMS OR END WALLS, PRESTRESSING STRANDS MAY EXTEND A MAXIMUM OF 2" BEYOND THE GIRDER ENDS. OTHERWISE, PRESTRESSING STRANDS SHALL BE CUT FLUSH WITH THE GIRDER ENDS.

THE TRANSFER OF LOAD FROM THE ANCHORAGES TO THE GIRDER SHALL BE DONE WHEN CONCRETE HAS REACHED A COMPRESSIVE STRENGTH OF NOT LESS THAN 5200 PSI.

DEPENDING ON THE TYPE OF SYSTEM USED TO SUPPORT THE DECK SLAB FORMS, PRESET ANCHORS MAY BE NECESSARY IN THE PRESTRESSED CONCRETE GIRDER.

THE TOP SURFACE OF THE GIRDER, EXCLUDING THE OUTSIDE 4", SHALL BE RAKED TO A DEPTH OF 1/4".

THE CONTRACTOR HAS THE OPTION TO PROVIDE, AT NO ADDITIONAL COST TO THE DEPARTMENT, 2 ADDITIONAL STRANDS AT THE TOP OF THE GIRDER TO FACILITATE TYING OF THE REINFORCING STEEL. THESE STRANDS SHALL BE PULLED TO A LOAD OF 4500 lbs.

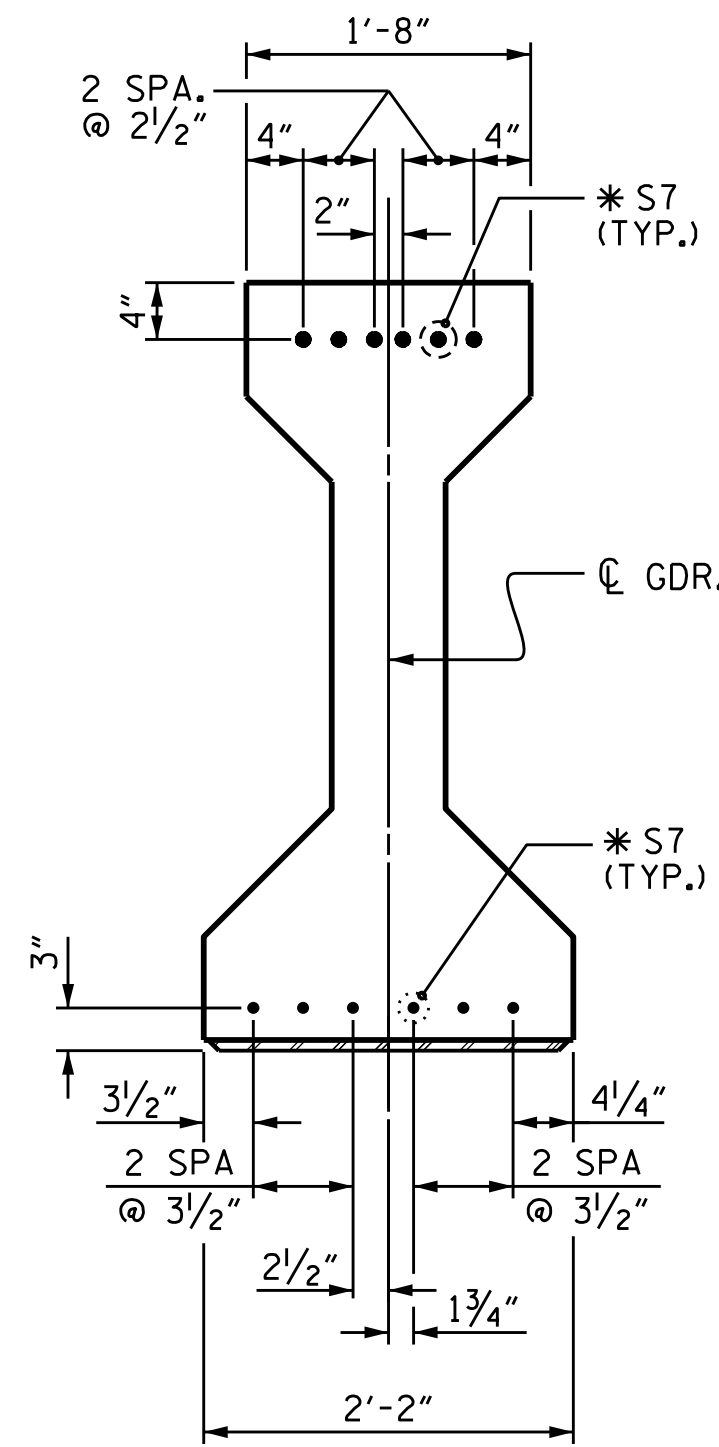

DETAIL "A"

(FOR AASHTO TYPE IV GIRDERS)

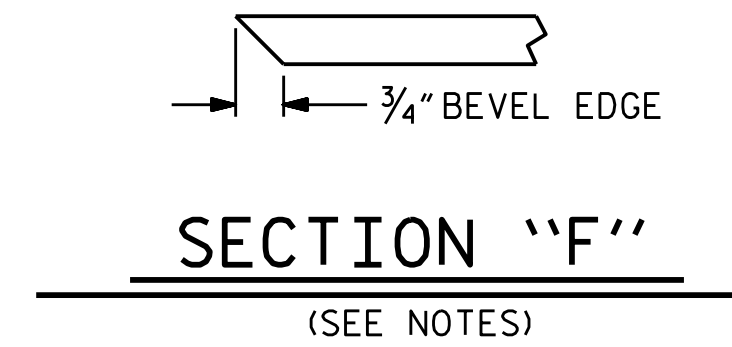
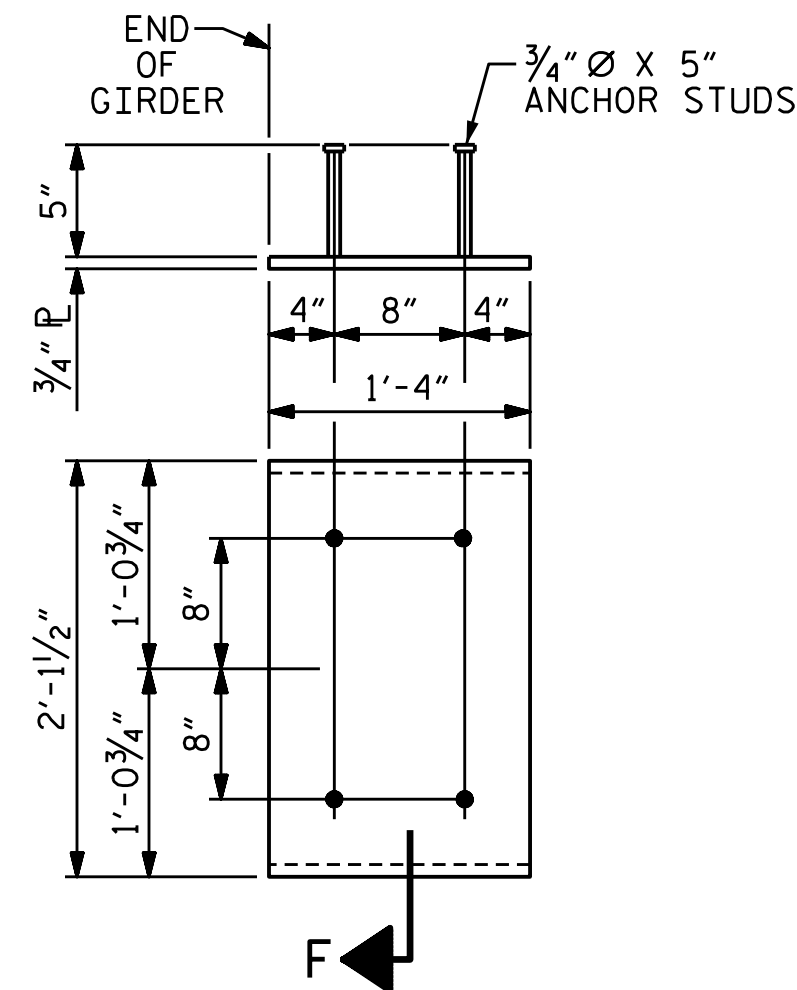

EMBEDDED PLATE "B-1" DETAILS FOR AASHTO TYPE IV GIRDER

(2 REQ'D PER GIRDER)

DEAD LOAD DEFLECTION TABLE FOR SPAN A																						
0.6" Ø LOW RELAXATION		GIRDER 1 & 4																				
TWENTIETH POINTS		0	.05	.1	.15	.2	.25	.3	.35	.4	.45	.5	.55	.6	.65	.7	.75	.8	.85	.9	.95	0
CAMBER (GIRDER ALONE IN PLACE) †		0.000	0.020	0.040	0.058	0.075	0.090	0.103	0.113	0.120	0.126	0.125	0.120	0.113	0.103	0.090	0.075	0.058	0.040	0.020	0.000	
* DEFLECTION DUE TO SUPERIMPOSED D.L. †		0.000	0.013	0.026	0.038	0.050	0.059	0.068	0.074	0.079	0.082	0.083	0.082	0.079	0.074	0.068	0.059	0.050	0.038	0.026	0.013	0.000
FINAL CAMBER †		0	1/16"	3/16"	1/4"	5/16"	3/8"	7/16"	7/16"	1/2"	1/2"	1/2"	1/2"	1/2"	7/16"	7/16"	3/8"	5/16"	1/4"	3/16"	1/16"	0

DEAD LOAD DEFLECTION TABLE FOR SPAN A																						
0.6" Ø LOW RELAXATION		GIRDERS 2 & 3																				
TWENTIETH POINTS		0	.05	.1	.15	.2	.25	.3	.35	.4	.45	.5	.55	.6	.65	.7	.75	.8	.85	.9	.95	0
CAMBER (GIRDER ALONE IN PLACE) †		0.000	0.020	0.040	0.058	0.075	0.088	0.102	0.112	0.120	0.124	0.126	0.124	0.120	0.112	0.102	0.088	0.075	0.058	0.040	0.020	0.000
* DEFLECTION DUE TO SUPERIMPOSED D.L. †		0.000	0.015	0.029	0.043	0.055	0.065	0.075	0.083	0.088	0.092	0.093	0.092	0.088	0.083	0.075	0.065	0.055	0.043	0.029	0.015	0.000
FINAL CAMBER †		0	1/16"	1/8"	3/16"	1/4"	1/4"	5/16"	3/8"	3/8"	3/8"	3/8"	3/8"	3/8"	5/16"	1/4"	1/4"	3/16"	1/8"	1/16"	0	0

DEAD LOAD DEFLECTION TABLE FOR SPAN B																						
0.6" Ø LOW RELAXATION		ALL GIRDERS																				
TWENTIETH POINTS		0	.05	.1	.15	.2	.25	.3	.35	.4	.45	.5	.55	.6	.65	.7	.75	.8	.85	.9	.95	0
CAMBER (GIRDER ALONE IN PLACE) †		0.000	0.024	0.047	0.069	0.089	0.107	0.122	0.135	0.143	0.149	0.151	0.149	0.143	0.135	0.122	0.107	0.089	0.069	0.047	0.024	0.000
* DEFLECTION DUE TO SUPERIMPOSED D.L. †		0.000	0.020	0.039	0.057	0.074	0.088	0.101	0.111	0.118	0.123	0.124	0.123	0.118	0.111	0.101	0.088	0.074	0.057	0.039	0.020	0.000
FINAL CAMBER †		0	1/16"	1/8"	1/8"	3/16"	1/4"	1/4"	5/16"	5/16"	5/16"	5/16"	5/16"	5/16"	5/16"	1/4"	1/4"	3/16"	1/8"	1/8"	1/16"	0

\* INCLUDES FUTURE WEARING SURFACE  
ALL VALUES ARE SHOWN IN FEET (DECIMAL FORM), EXCEPT "FINAL CAMBER", WHICH IS GIVEN IN INCHES (FRACTION FORM).

PROJECT NO. BR-0051  
YADKIN COUNTY  
STATION: 18+34.78 -L-

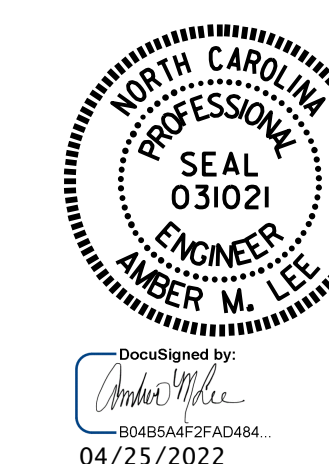

STATE OF NORTH CAROLINA  
DEPARTMENT OF TRANSPORTATION  
RALEIGH  
STANDARD  
PRESTRESSED CONCRETE GIRDER  
CONTINUOUS FOR LIVE LOAD  
DETAILS

ASSEMBLED BY : M. G. SHAIKH	DATE : 01/2022
CHECKED BY : H.A. LOCKLEAR	DATE : 03/2022
DRAWN BY : ELR 11/91	REV. 1/15 MAA/TMG
CHECKED BY : GRP 11/91	REV. 2/15 MAA/TMG
	REV. 12/17 MAA/THC

DOCUMENT NOT CONSIDERED  
FINAL UNLESS ALL  
SIGNATURES COMPLETED

REVISIONS						SHEET NO.
NO.	BY:	DATE:	NO.	BY:	DATE:	S-13
1			3			TOTAL SHEETS
2			4			32