

NOTES

THE BARRIER RAIL IN SPAN "A" SHALL NOT BE CAST UNTIL ALL SLAB CONCRETE IN THAT SPAN HAS BEEN CAST AND HAS REACHED A MINIMUM COMPRESSIVE STRENGTH OF 3,000 PSI.

WHEN FOAM JOINT SEAL IS REQUIRED, THE JOINT IN THE DECK SHALL BE SAWED PRIOR TO THE CASTING OF BARRIER RAIL.

ALL REINFORCING STEEL IN BARRIER RAILS SHALL BE EPOXY COATED.

THE #5S3 AND #5S4 BARS SHALL BE INSTALLED, USING AN ADHESIVE ANCHORING SYSTEM, AFTER SAWING THE JOINT. THE YIELD LOAD FOR THE #5S3 & #5S4 BARS IS 18.6 KIPS. FIELD TESTING FOR THE ADHESIVE BONDING SYSTEM IS NOT REQUIRED.

GROOVED CONTRACTION JOINTS, 1/2" IN DEPTH, SHALL BE TOOLED IN ALL EXPOSED FACES OF THE BARRIER RAIL AND IN ACCORDANCE WITH ARTICLE 825-10(B) OF THE STANDARD SPECIFICATIONS. THE CONTRACTION JOINT SHALL BE LOCATED AT EACH THIRD POINT BETWEEN BARRIER RAIL EXPANSION JOINTS. ONLY ONE CONTRACTION JOINT IS REQUIRED AT MIDPOINT OF BARRIER RAIL SEGMENTS LESS THAN 20 FEET IN LENGTH AND NO CONTRACTION JOINTS ARE REQUIRED FOR THOSE SEGMENTS LESS THAN 10 FEET IN LENGTH.

1/2" EXP. JT. MAT'L HELD IN PLACE WITH GALVANIZED NAILS.
(NOTE: OMIT EXP. JT. MAT'L. WHEN SLIP FORM IS USED.)

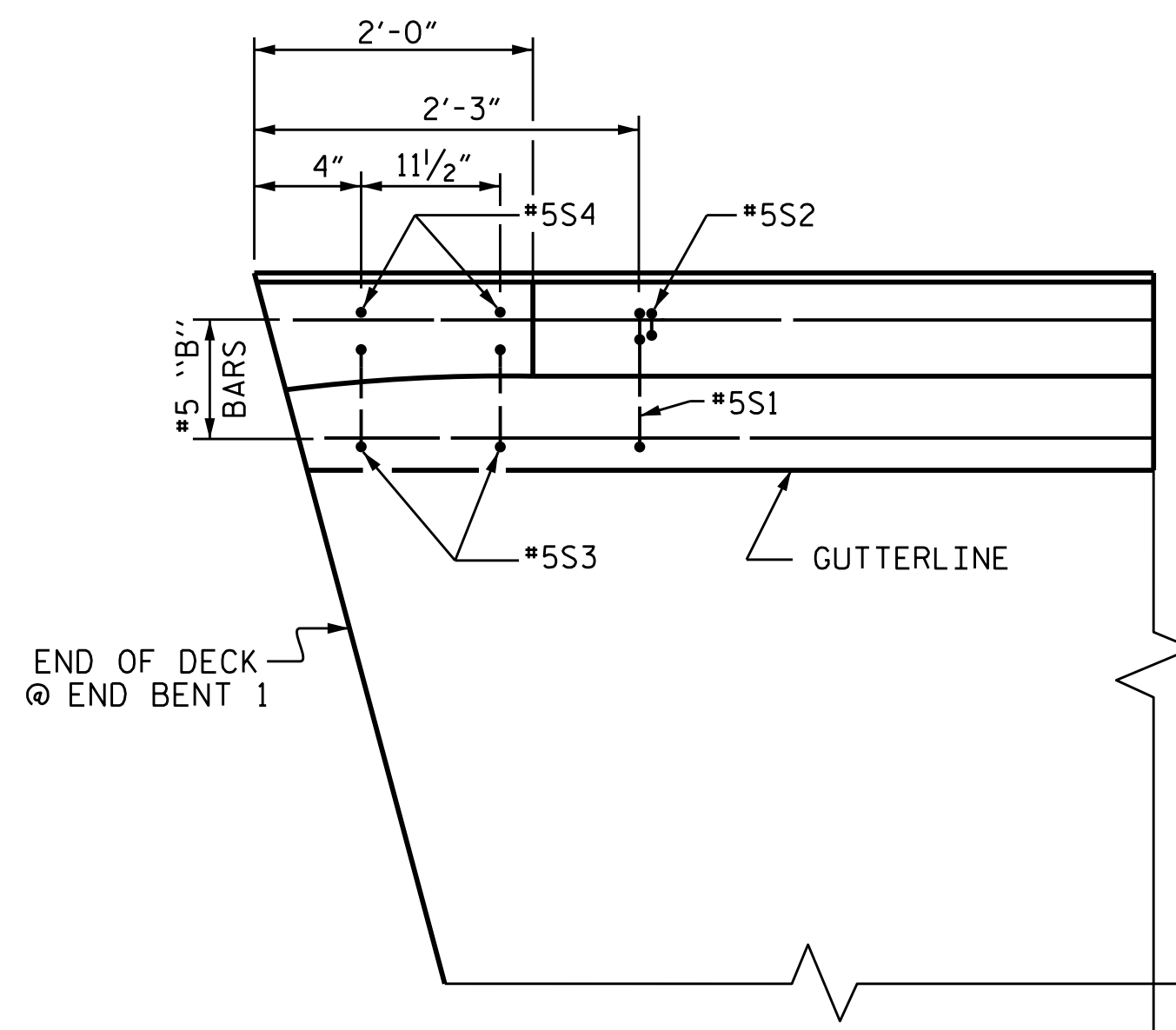

PLAN

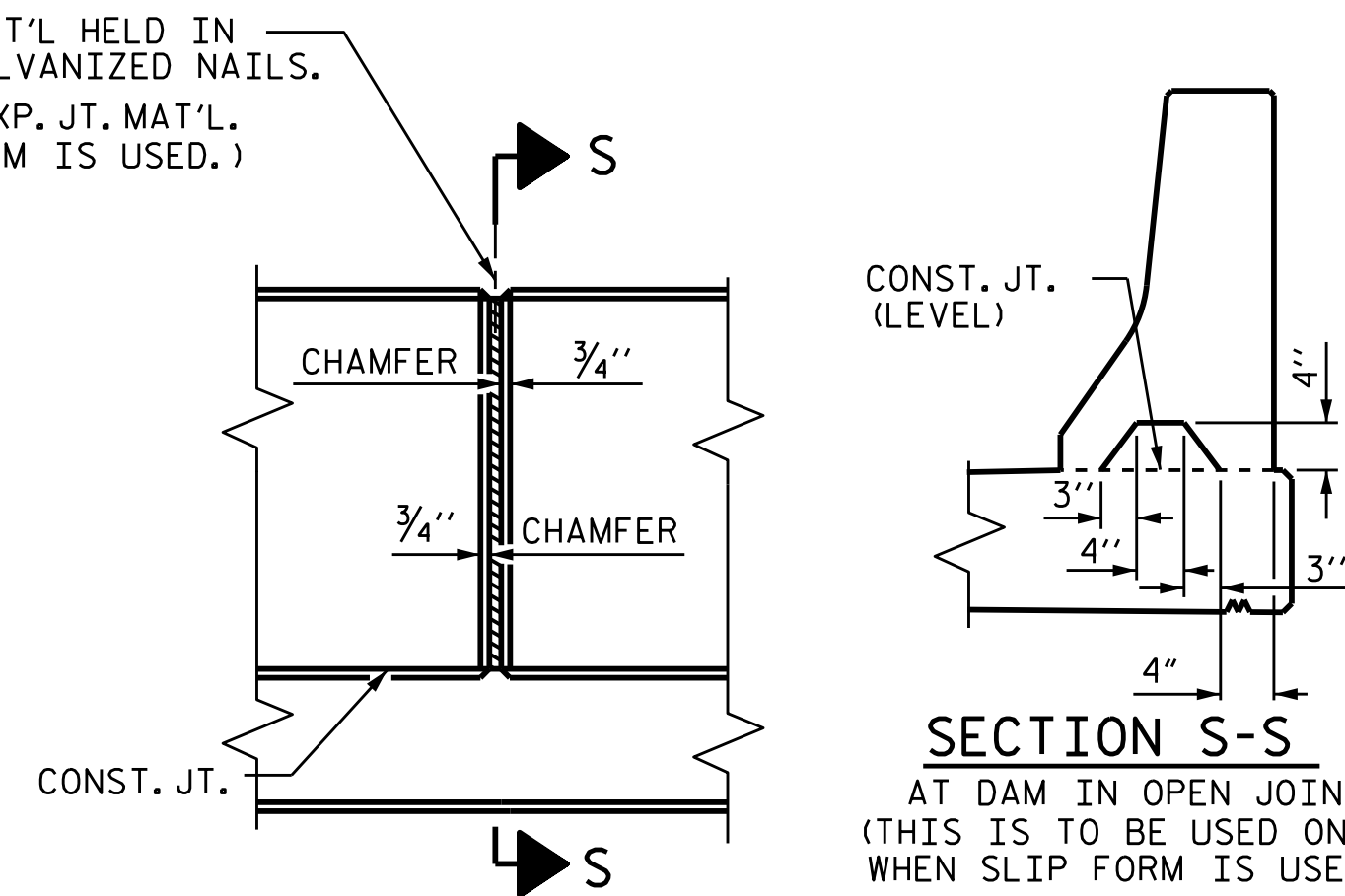

**ELEVATION AT EXPANSION JOINTS
BARRIER RAIL DETAILS**

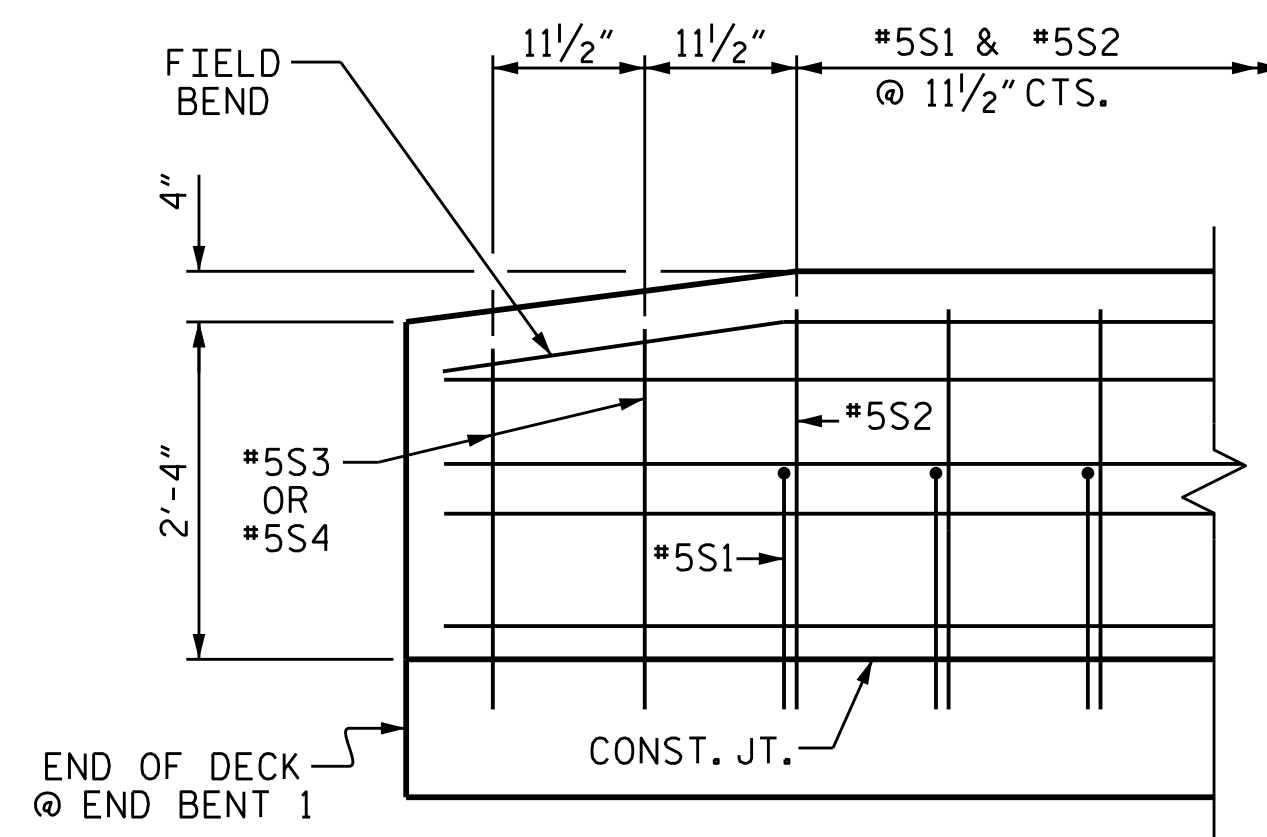

SIDE VIEW

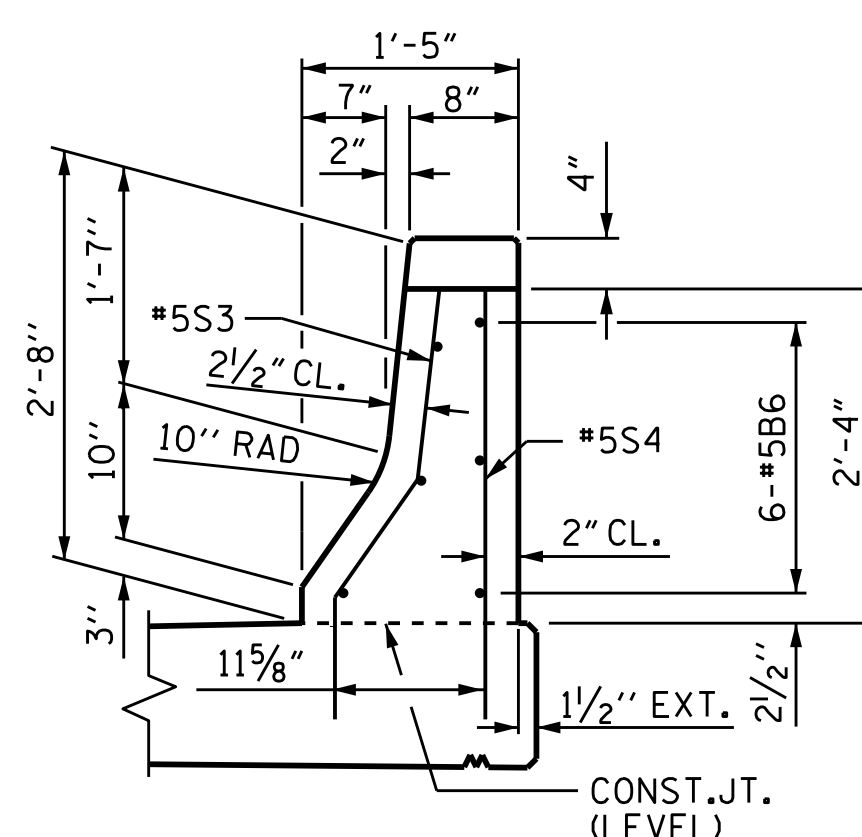

END VIEW

**END OF RAIL DETAILS
FOR ADHESIVE ANCHORING AT SAWED JOINTS**

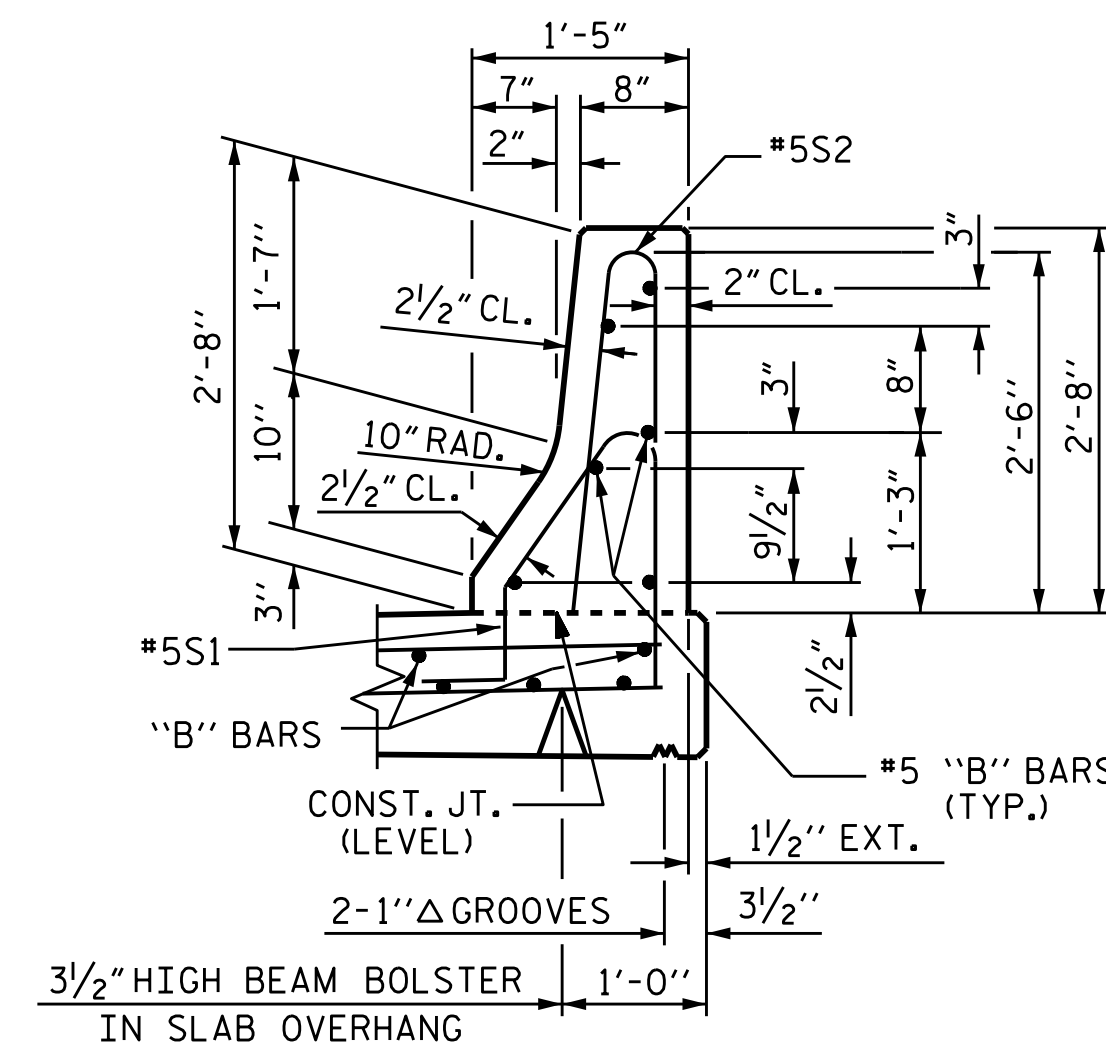

SECTION THRU RAIL

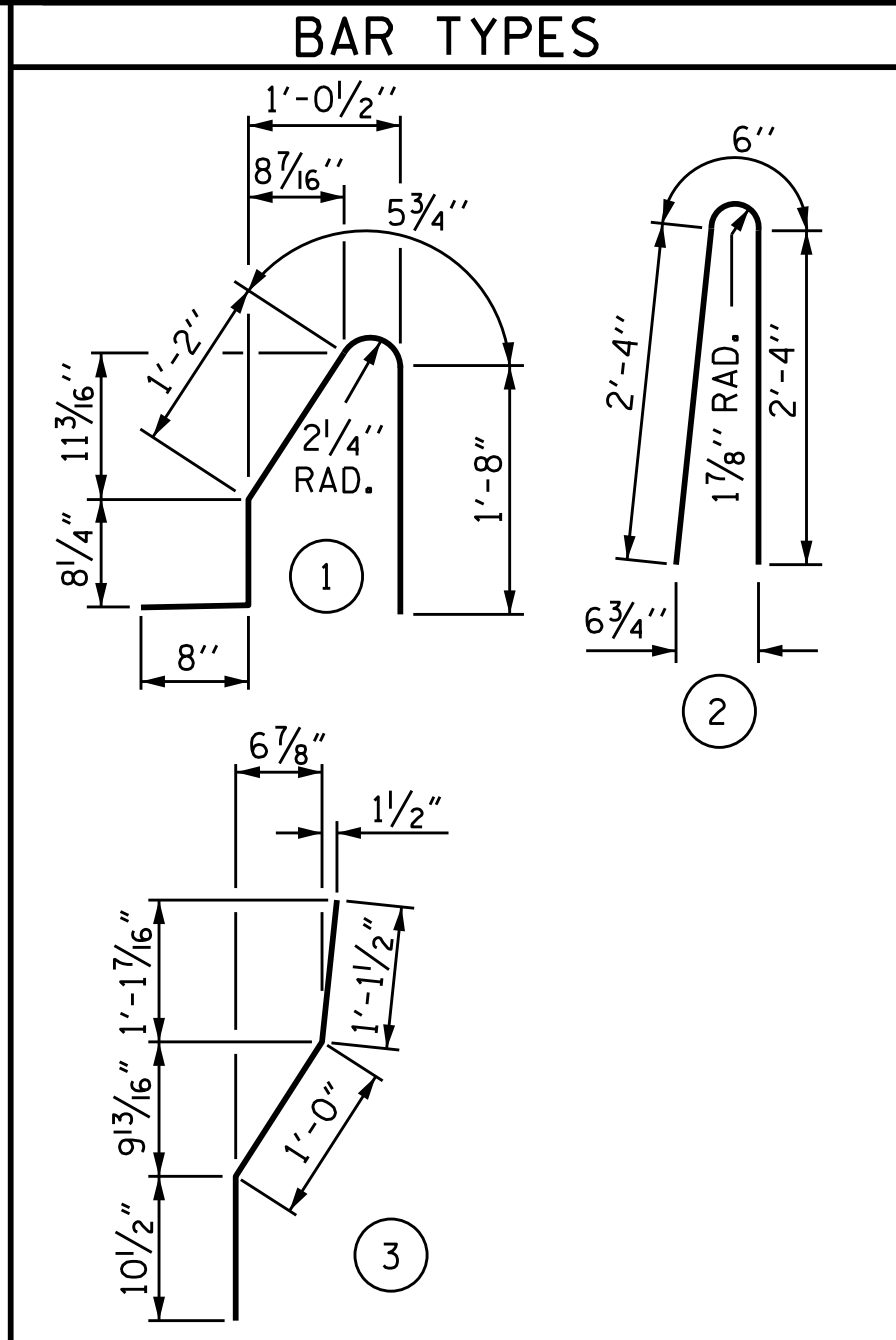

ALL BAR DIMENSIONS ARE OUT TO OUT

BILL OF MATERIAL

FOR CONCRETE BARRIER RAIL ONLY

BAR	NO.	SIZE	TYPE	LENGTH	WEIGHT
* B6	24	#5	STR	20'-7"	515
* B7	6	#5	STR	3'-7"	22
* S1	90	#5	1	4'-8"	438
* S2	90	#5	2	5'-2"	485
* S3	2	#5	3	3'-0"	6
* S4	2	#5	STR	2'-9"	6

* EPOXY COATED REINFORCING STEEL	1472 LBS.
CLASS AA CONCRETE	8.1 CU. YDS.
CONCRETE BARRIER RAIL	88.00 LIN. FT.

PROJECT NO. 41665.13C
PITT COUNTY
BRIDGE NO. 730472

SHEET 2 OF 2

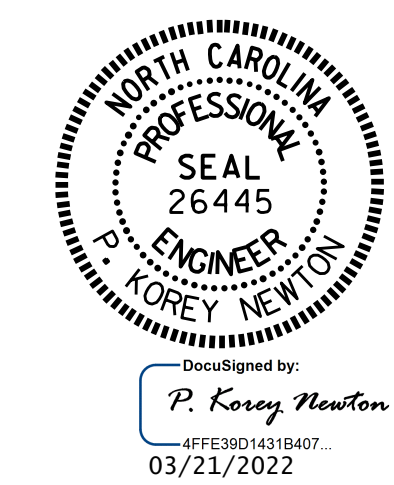

STATE OF NORTH CAROLINA
DEPARTMENT OF TRANSPORTATION
RALEIGH

CONCRETE BARRIER RAIL

REVISIONS						SHEET NO.
NO.	BY:	DATE:	NO.	BY:	DATE:	S2-11
1			3			TOTAL SHEETS
2			4			14

DOCUMENT NOT CONSIDERED FINAL UNLESS ALL SIGNATURES COMPLETED

ASSEMBLED BY : M.K. BEARD	DATE : 6/23/21
CHECKED BY : D.R. SHACKELFORD	DATE : 6/24/21
DRAWN BY : ARB 5/87	REV. 7/12
CHECKED BY : SJD 9/87	REV. 6/13
	REV. 12/17
	MAA/GM
	MAA/GM
	MAA/THC