

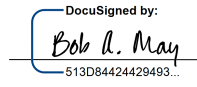

**This electronic collection of documents is provided  
for the convenience of the user  
and is Not a Certified Document –**

**The documents contained herein were originally issued  
and sealed by the individuals whose names and license  
numbers appear on each page, on the dates appearing  
with their signature on that page.**

**This file or an individual page  
shall not be considered a certified document.**

TIP NO.	SHEET NO.
R-4705	PMP-01
APPROVED: 	
DATE: 4/7/2022	
SEAL	
	
DOCUMENT NOT CONSIDERED FINAL UNLESS ALL SIGNATURES COMPLETED	

**STATE OF NORTH CAROLINA  
DEPARTMENT OF TRANSPORTATION**

**PAVEMENT MARKING PLAN  
MARTIN COUNTY**

**T.I.P.: R-4705**

**CONTRACT: NA**

**CONTRACT: NA**

**INDEX**

SHEET NO.	DESCRIPTION
PMP-1	PAVEMENT MARKING TITLE SHEET
PMP-1A	PAVEMENT MARKING SCHEDULE SHEET
PMP-2 TO PMP-25	PAVEMENT MARKING DETAIL

**ROADWAY STANDARD DRAWING**

THE FOLLOWING ROADWAY STANDARDS AS APPEAR IN "ROADWAY STANDARD DRAWINGS" - PROJECT SERVICES UNIT - N.C. DEPARTMENT OF TRANSPORTATION - RALEIGH, N.C., DATED JANUARY 2018 ARE APPLICABLE TO THIS PROJECT AND BY REFERENCE HEREBY ARE CONSIDERED A PART OF THESE PLANS:

STD. NO.	TITLE
1205.01	PAVEMENT MARKINGS - LINE TYPES AND OFFSETS
1205.02	PAVEMENT MARKINGS - TWO-LANE AND MULTILANE ROADWAYS
1205.03	PAVEMENT MARKINGS - EXIT AND ENTRANCE RAMP
1205.04	PAVEMENT MARKINGS - INTERSECTIONS
1205.05	PAVEMENT MARKINGS - TURN LANES
1205.06	PAVEMENT MARKINGS - LANE DROPS
1205.08	PAVEMENT MARKINGS - SYMBOLS AND WORD MESSAGES
1205.09	PAVEMENT MARKINGS - PAINTED ISLANDS
1205.12	PAVEMENT MARKINGS - BRIDGES
1250.01	RAISED PAVEMENT MARKERS - INSTALLATION SPACING
1251.01	RAISED PAVEMENT MARKERS - PERMANENT AND TEMPORARY
1253.01	RAISED PAVEMENT MARKERS - SNOWPLOWABLE

**GENERAL NOTES**

THE FOLLOWING GENERAL NOTES APPLY AT ALL TIMES FOR THE DURATION OF THE CONSTRUCTION PROJECT, EXCEPT WHEN OTHERWISE NOTED IN THE PLAN, OR DIRECTED BY THE ENGINEER.

A) INSTALL PAVEMENT MARKINGS AND PAVEMENT MARKERS ON THE FINAL SURFACE AS FOLLOWS:

ROAD NAME	MARKING	MARKER
-L- PRISON CAMP RD	THERMOPLASTIC	SNOWPLOWABLE MARKERS
-L- BRIDGE OVER US-13	COLD APPLIED PLASTIC - TYPE 2	SNOWPLOWABLE MARKERS
-Y1- NC-903	THERMOPLASTIC	SNOWPLOWABLE MARKERS
ALL OTHER -Y- LINES	THERMOPLASTIC	N/A

B) TIE PROPOSED PAVEMENT MARKING LINES TO EXISTING PAVEMENT MARKING LINES.

C) REMOVE/REPLACE ANY CONFLICTING/DAMAGED PAVEMENT MARKINGS AND MARKERS.

D) PASSING ZONES WILL BE DETERMINED IN THE FIELD AND MUST BE APPROVED BY THE ENGINEER.

E) STOP BAR LOCATION AT NON-SIGNALIZED INTERSECTIONS MAY BE ADJUSTED AS DIRECTED BY THE ENGINEER.

F) REMOVE ALL RESIDUE AND SURFACE LAITANCE BY ACCEPTABLE METHODS ON CONCRETE BRIDGE DECKS PRIOR TO PLACING CONTRAST COLD APPLIED PLASTIC PAVEMENT MARKING MATERIAL.

G) UNLESS OTHERWISE SPECIFIED, HEATED-IN-PLACE THERMOPLASTIC MAY BE USED IN LIEU OF EXTRUDED THERMOPLASTIC FOR STOP BARS, SYMBOLS, CHARACTERS AND DIAGONALS. IF HEATED-IN-PLACE IS USED, IT SHALL BE PAID FOR USING THE EXTRUDED THERMOPLASTIC PAY ITEM.

H) UNLESS OTHERWISE SPECIFIED, HEATED-IN-PLACE THERMOPLASTIC MAY BE USED IN LIEU OF COLD APPLIED PLASTIC FOR STOP BARS, SYMBOLS, CHARACTERS AND DIAGONALS ON ASPHALT OR CONCRETE ROADWAYS. IF HEATED-IN-PLACE IS USED, IT SHALL BE PAID FOR USING THE COLD APPLIED PAY ITEM.

I) TYPE III COLD APPLIED PLASTIC MAY BE USED IN LIEU OF TYPE II COLD APPLIED PLASTIC. IF TYPE III COLD APPLIED PLASTIC IS USED, IT SHALL BE PAID FOR USING THE TYPE II COLD APPLIED PLASTIC PAY ITEM.

**PLAN SUBMITTED TO:**

**JASON DAVIDSON** DIVISION 1 TRAFFIC ENGINEER  
**AYMAN ALQUDWAH, PE** SIGNING AND DELINEATION REGIONAL ENGINEER

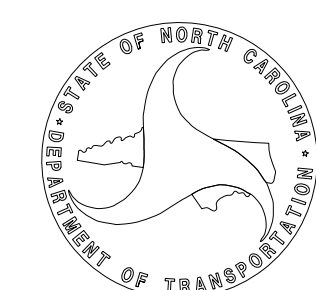

**PLAN PREPARED BY: WEI, INC**

**BOB MAY, PE** PROJECT MANAGER  
**ALLEN HAYES, EI** TRAFFIC DESIGN ENGINEER

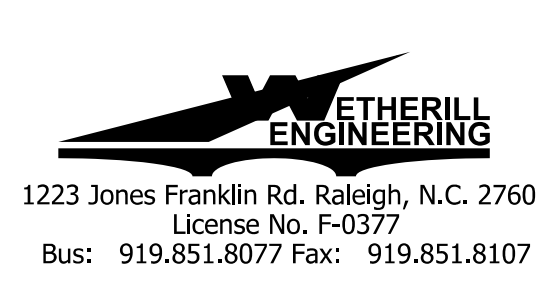

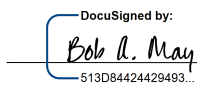
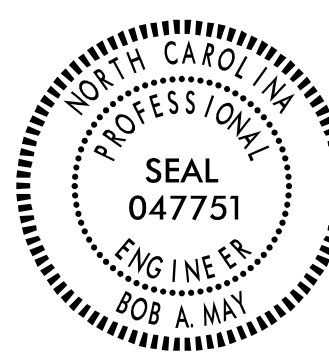
TIP NO.	SHEET NO.
R - 4705	PMP - 01A
APPROVED: 	
DATE: 4/7/2022	
SEAL 	
DOCUMENT NOT CONSIDERED FINAL UNLESS ALL SIGNATURES COMPLETED	

**PAVEMENT MARKING SCHEDULE**

SYMBOL	DESCRIPTION
T1	WHITE EDGELINE (4", 90 MIL)
T2	WHITE SOLID LANE LINE (4", 90 MIL)
T4	3 FT. - 9 FT./SP WHITE MINISKIP (4", 90 MIL)
T5	2 FT. - 6 FT./SP WHITE MINISKIP (4", 90 MIL)
T10	YELLOW EDGELINE (4", 90 MIL)
T11	YELLOW SINGLE CENTER (4", 90 MIL)
T12	10 FT. YELLOW SKIP (4", 90 MIL)
T13	YELLOW DOUBLE CENTER (4", 90 MIL)
T14	2 FT. - 6 FT./SP YELLOW MINISKIP (4", 90 MIL)
T40	WHITE GORELINE (8", 90 MIL)
T43	WHITE SOLID LANE LINE (8", 90 MIL)
T44	3 FT. - 9 FT./SP WHITE MINISKIP (8", 90 MIL)
T51	WHITE DIAGONAL (12", 90 MIL)
T52	YELLOW DIAGONAL (12", 90 MIL)
T61	WHITE STOPBAR (24", 90 MIL)
T70	LEFT TURN ARROW (90 MIL)
T71	RIGHT TURN ARROW (90 MIL)
T72	STRAIGHT ARROW (90 MIL)
T73	COMBO. LEFT/STRAIGHT ARROW (90 MIL)
T74	COMBO. RIGHT/STRAIGHT ARROW (90 MIL)
T75	COMBO. LEFT/RIGHT ARROW (90 MIL)
T76	COMBO. LEFT/RIGHT/STRAIGHT ARROW (90 MIL)
T80	WRONG-WAY RAMP ARROW (90 MIL)
T100	ALPHANUMERIC CHAR. (90 MIL)
T103	24" YIELD LINE TRIANGLE (90 MIL)
C1	WHITE EDGELINE (4")
C13	YELLOW DOUBLE CENTER (4")
C52	YELLOW DIAGONAL (12")
ME	NON-CAST IRON SNOWPLOWABLE MARKER - YELLOW & YELLOW
MF	NON-CAST IRON SNOWPLOWABLE MARKER - CRYSTAL & RED

3/11/2022  
 P:\2022\175.01.R-4705-Find\Traffic\Signing and Delineation\ Pavement Markings\Sheets\R-4705\_PMP\_01A.dgn  
 User: AH01es



1223 Jones Franklin Rd.  
 Raleigh, N.C. 27606  
 License No. F-0377  
 Bus: 919 851 8077  
 Fax: 919 851 8107

TRANSPORTATION PLANNING/DESIGN - BRIDGE/STRUCTURE DESIGN  
 CIVIL/SITE DESIGN - GIS/GPS - CONSTRUCTION OBSERVATION

**PAVEMENT MARKING SCHEDULE SHEET**

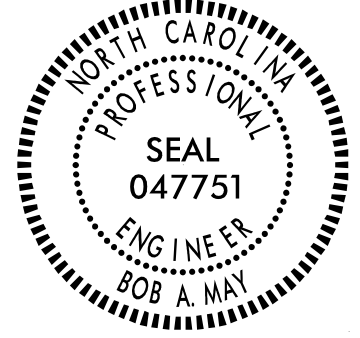
TIP NO. R - 4705	SHEET NO. PMP - 02
APPROVED: <i>Bob A. May</i> 4/7/2022	
SEAL 	
DOCUMENT NOT CONSIDERED FINAL UNLESS ALL SIGNATURES COMPLETED	

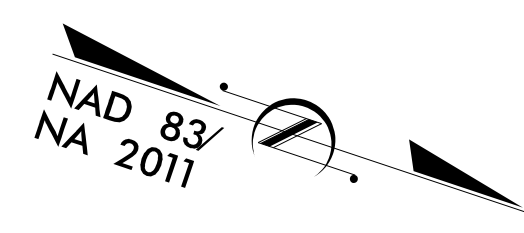

25

15

20

TIE INTO EXISTING  
PAVEMENT MARKINGS &  
BEGIN TAPER

TIE INTO EXISTING  
PAVEMENT MARKINGS  
& END TAPER

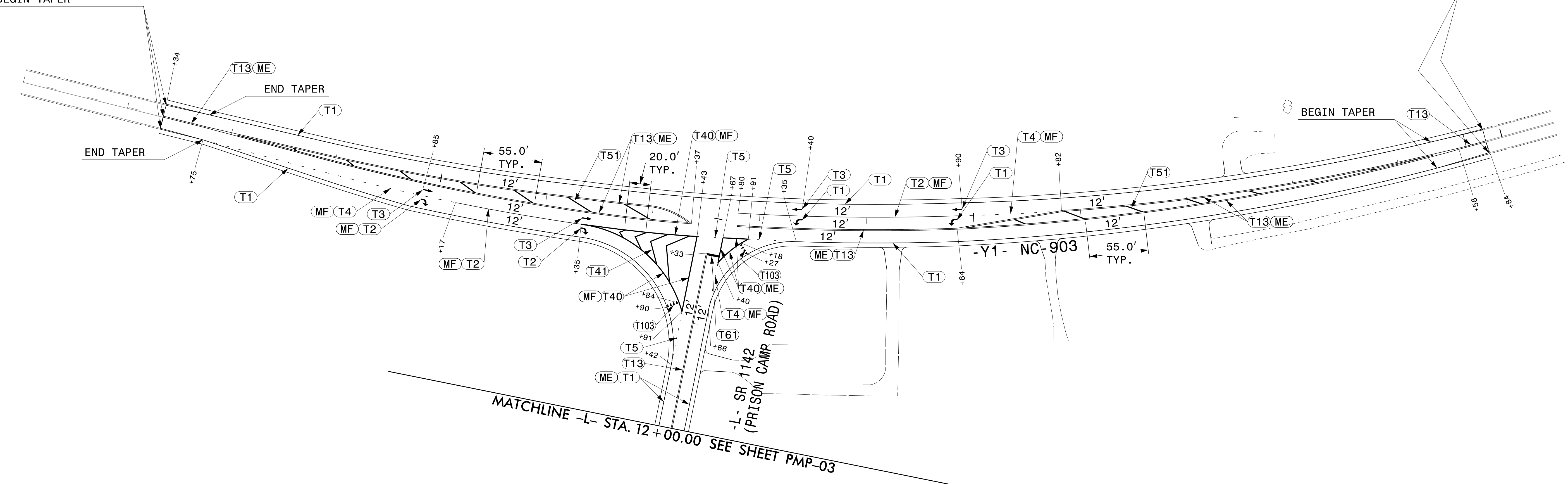



3/11/2022  
P:\2022\175.01.R-4705-Traffic\Signing and Delineation\ Pavement Markings\Sheets\R-4705\_PMP\_02.dgn  
User: AH01/e/s

**ETHERILL ENGINEERING**  
 1223 Jones Franklin Rd.  
 Raleigh, N.C. 27606  
 License No. F-0377  
 Bus: 919 851 8077  
 Fax: 919 851 8107

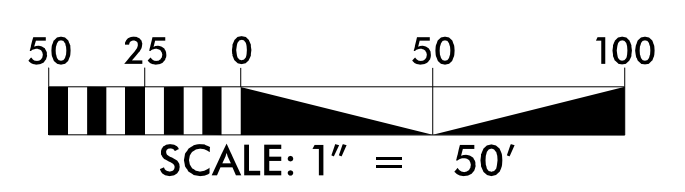
TRANSPORTATION PLANNING/DESIGN - BRIDGE/STRUCTURE DESIGN  
 CIVIL/SITE DESIGN - GIS/GPS - CONSTRUCTION OBSERVATION

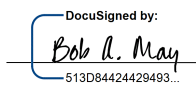

**PAVEMENT MARKING PLAN SHEET**

TIP NO.	SHEET NO.
R - 4705	PMP - 03
APPROVED: 	
DATE: 4/7/2022	
SEAL	
	
DOCUMENT NOT CONSIDERED FINAL UNLESS ALL SIGNATURES COMPLETED	

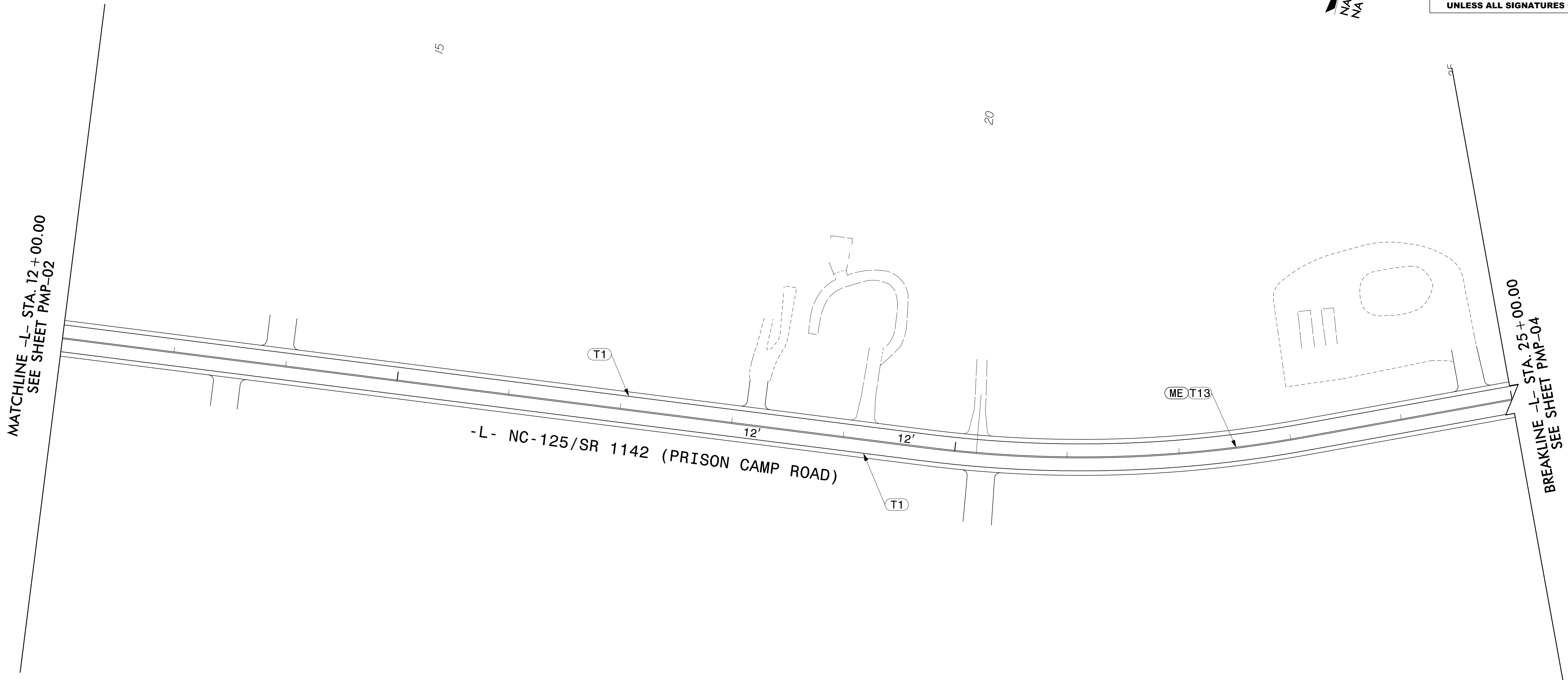
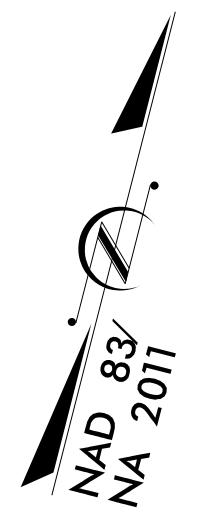

3/11/2022  
 P:\2022\175.OLR-4705-Find\Traffic\Signing and Delineation\Pavement Markings\Sheets\R-4705\_PMP\_03.dgn  
 User: AH01es

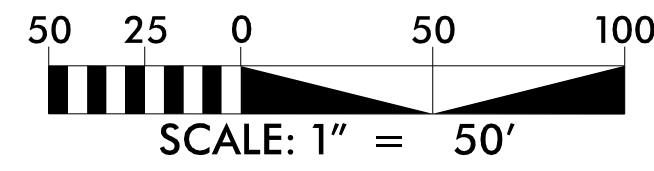

**ETHERILL ENGINEERING**  
 1223 Jones Franklin Rd.  
 Raleigh, N.C. 27606  
 License No. F-0377  
 Bus: 919 851 8077  
 Fax: 919 851 8107

TRANSPORTATION PLANNING/DESIGN - BRIDGE/STRUCTURE DESIGN  
 CIVIL/SITE DESIGN - GIS/GPS - CONSTRUCTION OBSERVATION

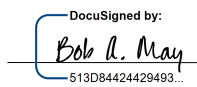
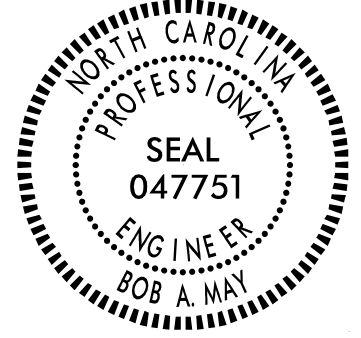

**PAVEMENT MARKING PLAN SHEET**

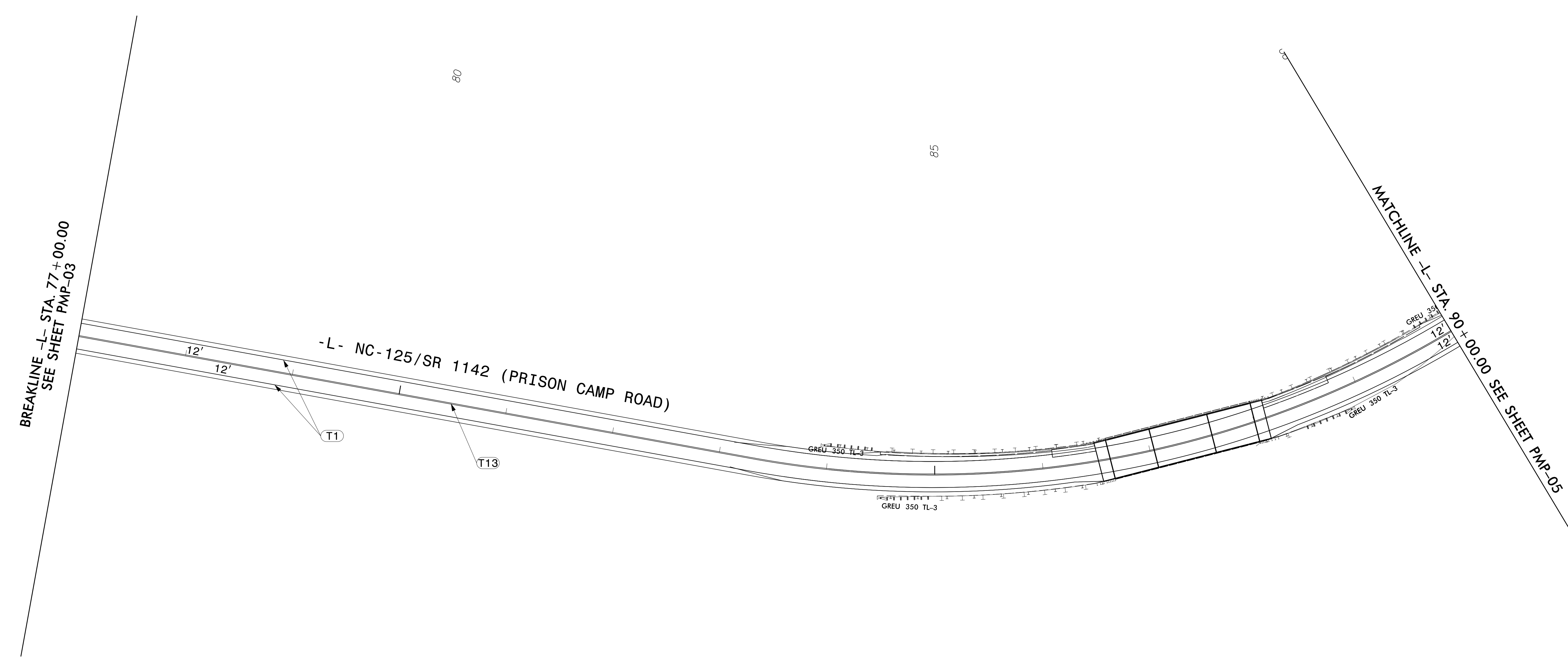
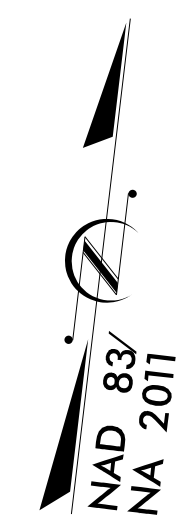
TIP NO. R-4705	SHEET NO. PMP-04
APPROVED:  DATE: 4/7/2022	
SEAL 	
DOCUMENT NOT CONSIDERED FINAL UNLESS ALL SIGNATURES COMPLETED	



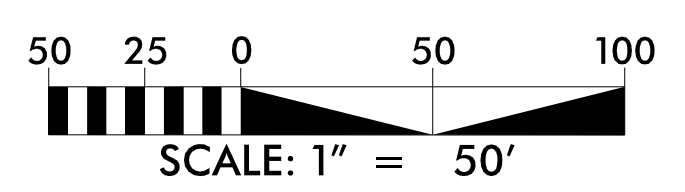

3/11/2022  
 P:\2022\175.OLR-4705-Find\Traffic\Signing and Delineation\Pavement Markings\Sheets\R-4705\_PMP\_04.dgn  
 User: AH01es

**ETHERILL ENGINEERING**  
 1223 Jones Franklin Rd.  
 Raleigh, N.C. 27606  
 License No. F-0377  
 Bus: 919 851 8077  
 Fax: 919 851 8107  
 TRANSPORTATION PLANNING/DESIGN - BRIDGE/STRUCTURE DESIGN  
 CIVIL/SITE DESIGN - GIS/GPS - CONSTRUCTION OBSERVATION

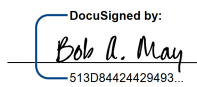

**PAVEMENT MARKING PLAN SHEET**

TIP NO. R - 4705	SHEET NO. PMP - 05
APPROVED:  DATE: 4/7/2022	
SEAL 	
DOCUMENT NOT CONSIDERED FINAL UNLESS ALL SIGNATURES COMPLETED	

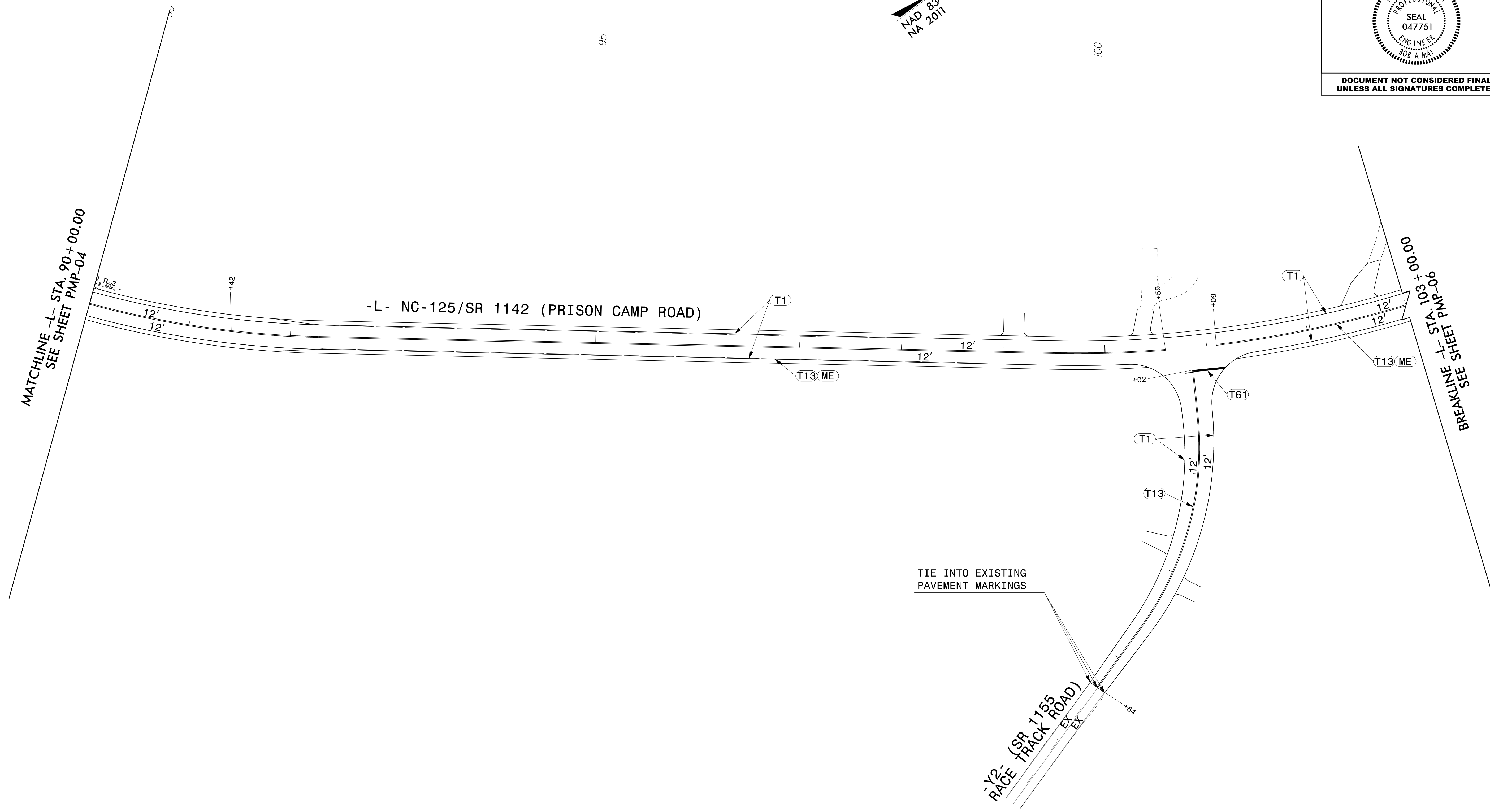

3/11/2022  
P:\2022\175.OLR-4705-Traffic\Signing and Delineation\Pavement Markings\Sheets\R-4705\_PMP\_05.dgn  
User: AH01es

**ETHERILL ENGINEERING**  
 1223 Jones Franklin Rd.  
 Raleigh, N.C. 27606  
 License No. F-0377  
 Bus: 919 851 8077  
 Fax: 919 851 8107

TRANSPORTATION PLANNING/DESIGN - BRIDGE/STRUCTURE DESIGN  
 CIVIL/SITE DESIGN - GIS/GPS - CONSTRUCTION OBSERVATION

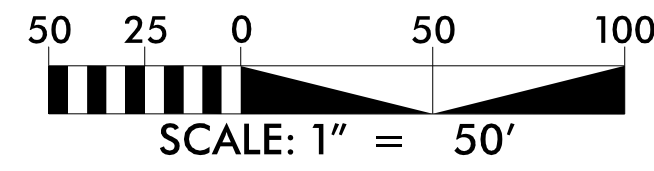

**PAVEMENT MARKING PLAN SHEET**

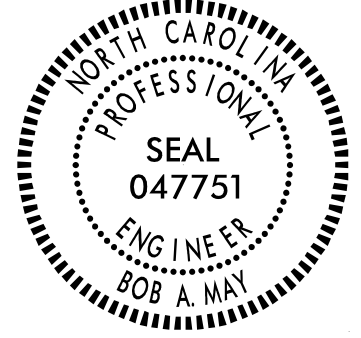
TIP NO. R-4705	SHEET NO. PMP-06
APPROVED: <i>Bob H. May</i> 4/7/2022	
SEAL 	
DOCUMENT NOT CONSIDERED FINAL UNLESS ALL SIGNATURES COMPLETED	

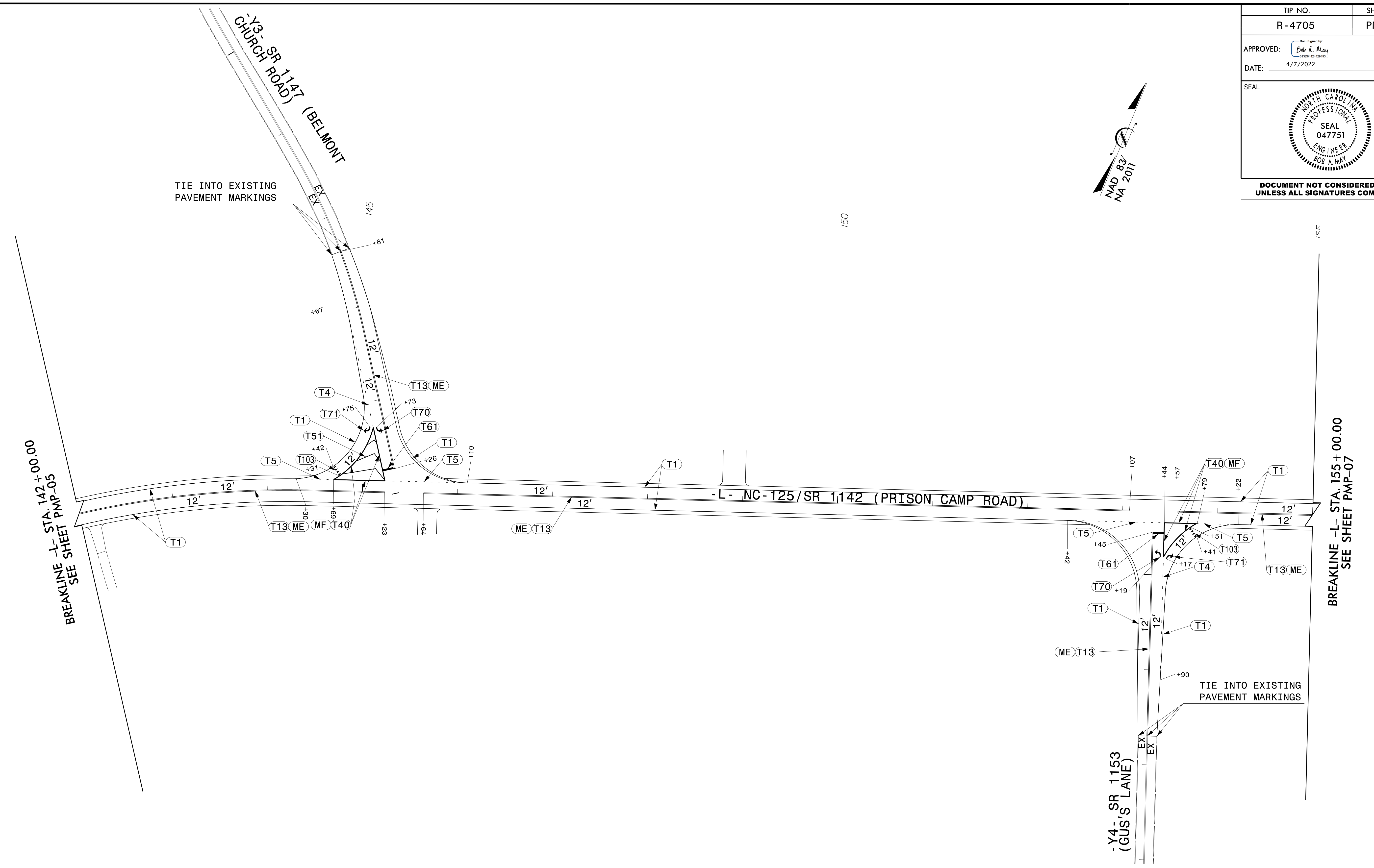
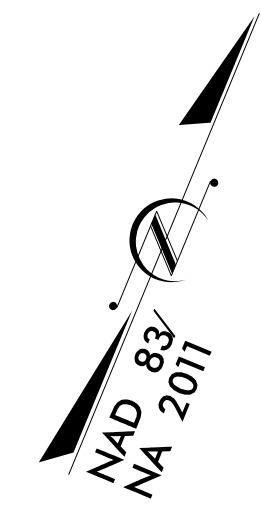

**ETHERILL ENGINEERING**  
 1223 Jones Franklin Rd.  
 Raleigh, N.C. 27606  
 License No. F-0377  
 Bus: 919 851 8077  
 Fax: 919 851 8107

TRANSPORTATION PLANNING/DESIGN - BRIDGE/STRUCTURE DESIGN  
 CIVIL/SITE DESIGN - GIS/GPS - CONSTRUCTION OBSERVATION

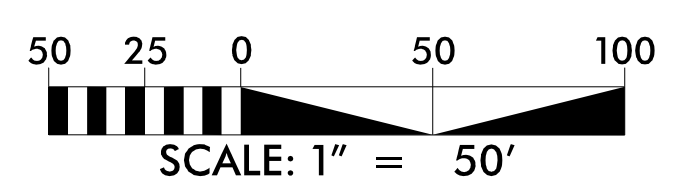



**PAVEMENT MARKING PLAN SHEET**

3/11/2022  
 P:\2021\175.OLR-4705-Traffic\Signing and Delineation\Pavement Markings\Sheets\R-4705\_PMP\_06.dgn  
 User: AH01es

BREAKLINE -L- STA 142+00.00  
 SEE SHEET PMP-05

BREAKLINE -L- STA 155+00.00  
 SEE SHEET PMP-07

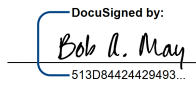

TIP NO.	SHEET NO.
R - 4705	PMP - 07
APPROVED: 	
DATE: 4/7/2022	
SEAL	
	
DOCUMENT NOT CONSIDERED FINAL UNLESS ALL SIGNATURES COMPLETED	

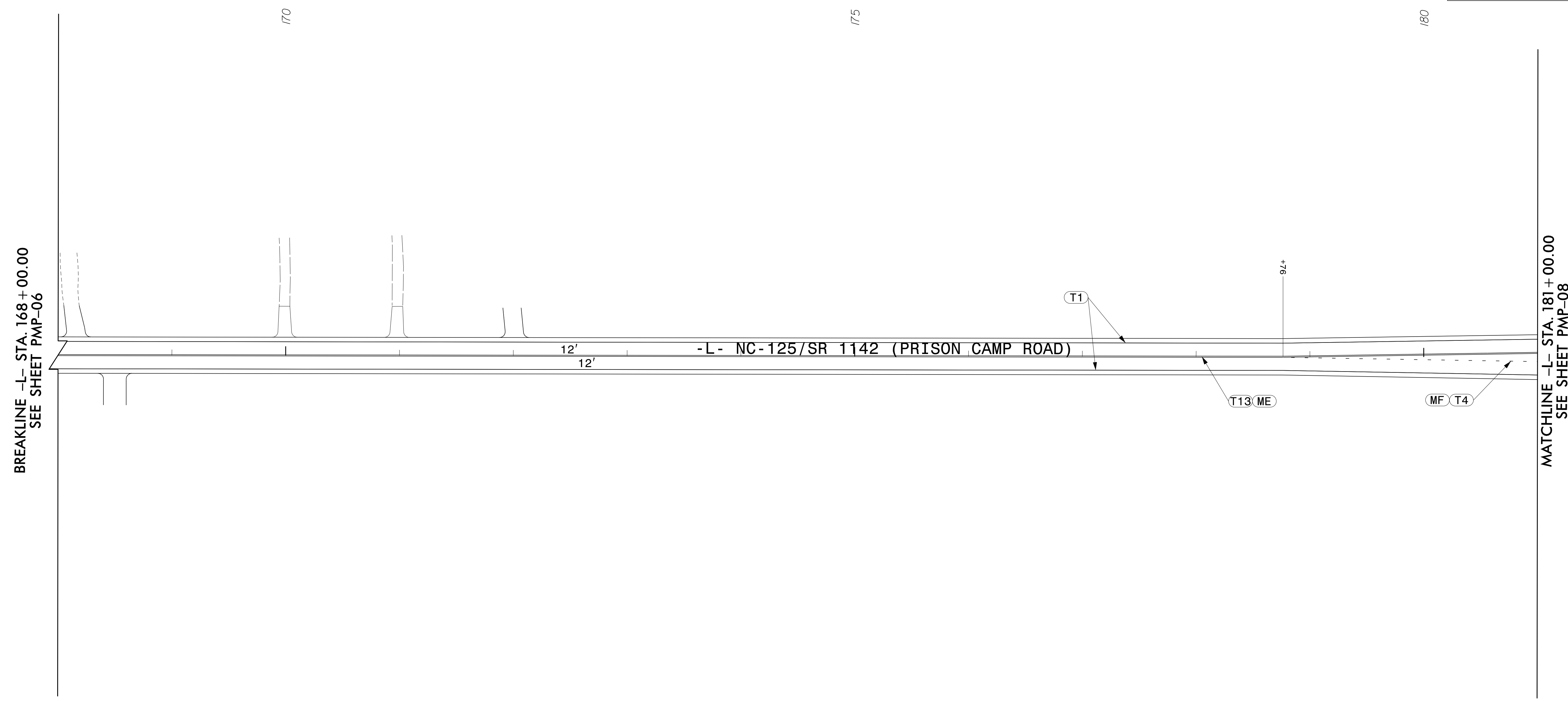
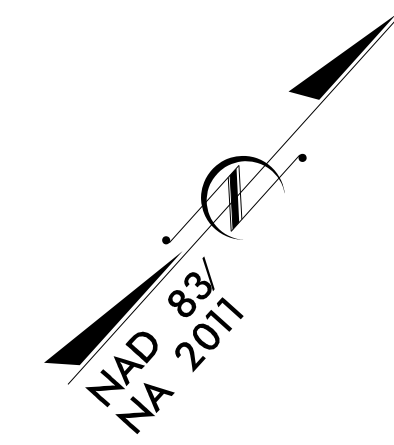

BREAKLINE -L- STA. 168+00.00  
SEE SHEET PMP-06

MATCHLINE -L- STA. 181+00.00  
SEE SHEET PMP-08

3/11/2022  
 P:\2022\175.OLR-4705-Find\Traffic\Signing and Delineation\Pavement Markings\Sheets\R-4705\_PMP\_07.dgn  
 User: AH01es

**ETHERILL ENGINEERING**  
 1223 Jones Franklin Rd.  
 Raleigh, N.C. 27606  
 License No. F-0377  
 Bus: 919 851 8077  
 Fax: 919 851 8107  
TRANSPORTATION PLANNING/DESIGN - BRIDGE/STRUCTURE DESIGN  
 CIVIL/SITE DESIGN - GIS/GPS - CONSTRUCTION OBSERVATION

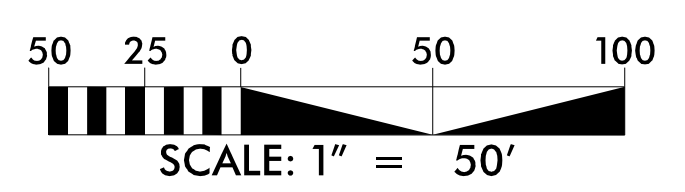

**PAVEMENT MARKING PLAN SHEET**

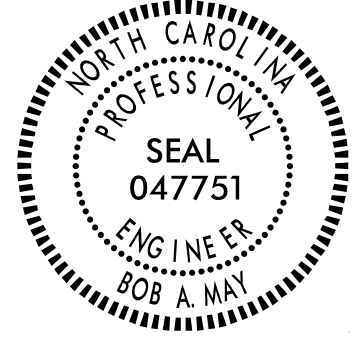
TIP NO. R-4705	SHEET NO. PMP-08
APPROVED: <i>Bob L. May</i> 510442423983	
DATE: 4/7/2022	
SEAL 	
DOCUMENT NOT CONSIDERED FINAL UNLESS ALL SIGNATURES COMPLETED	

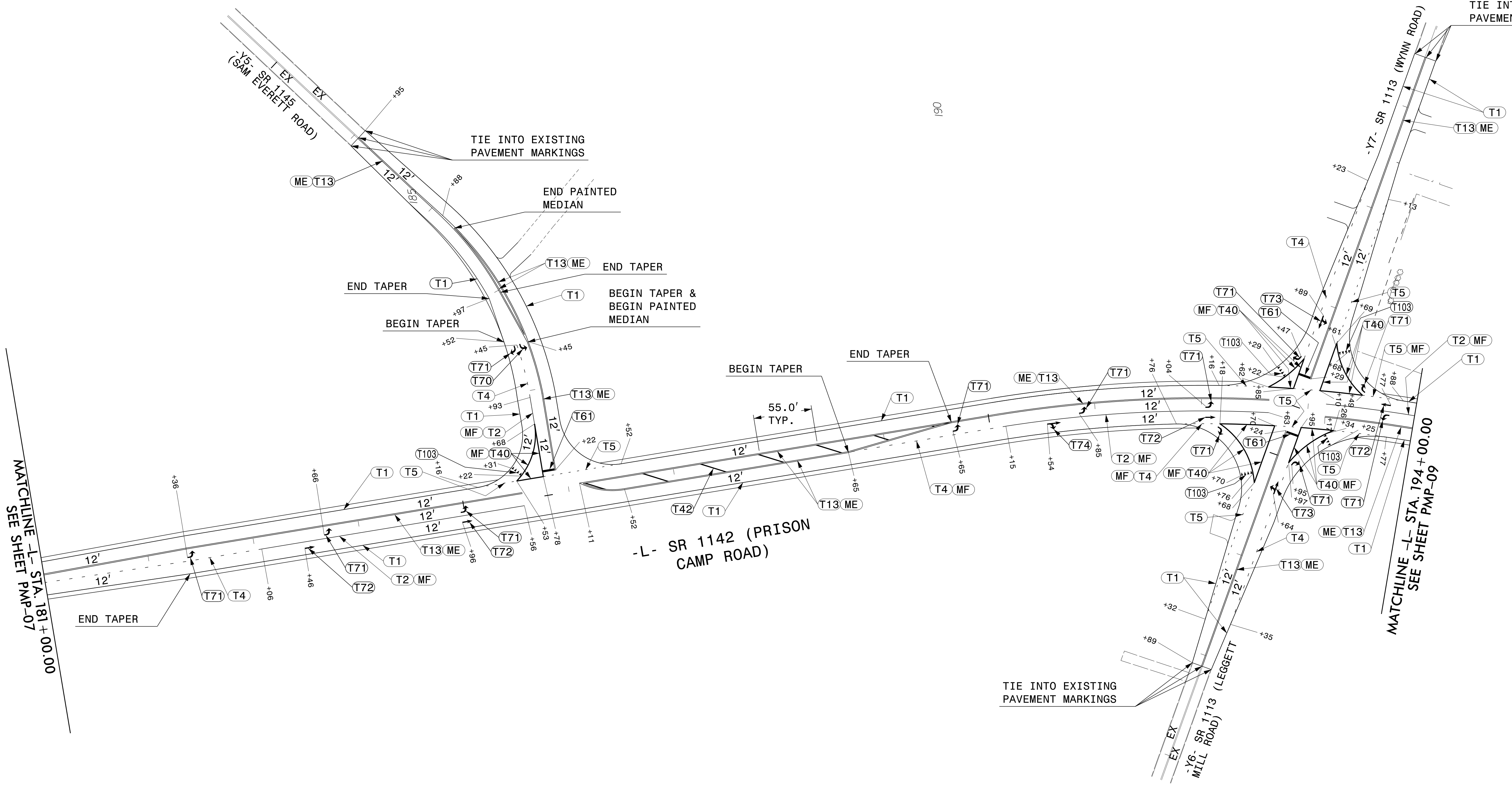
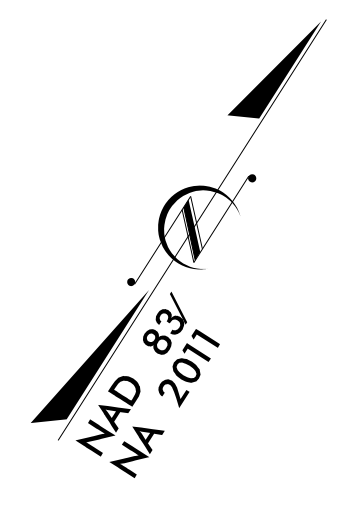

MATCHLINE - L- STA. 181+00.00  
SEE SHEET PMP-07

MATCHLINE - L- STA. 194+00.00  
SEE SHEET PMP-09

-L- SR 1142 (PRISON  
CAMP ROAD)

-Y6- SR 1113 (LEGGETT  
MILL ROAD)

TIE INTO EXISTING  
PAVEMENT MARKINGS

TIE INTO EXISTING  
PAVEMENT MARKINGS

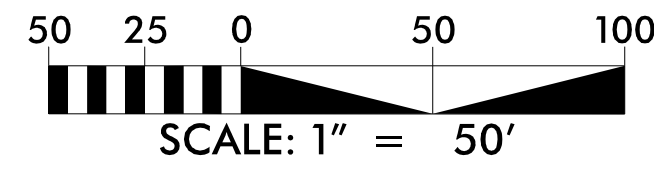

**ETHERILL ENGINEERING**  
 1223 Jones Franklin Rd.  
 Raleigh, N.C. 27606  
 License No. F-0377  
 Bus: 919 851 8077  
 Fax: 919 851 8107

TRANSPORTATION PLANNING/DESIGN - BRIDGE/STRUCTURE DESIGN  
 CIVIL/SITE DESIGN - GIS/GPS - CONSTRUCTION OBSERVATION

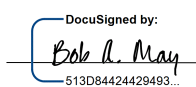

**PAVEMENT MARKING PLAN SHEET**

3/11/2022  
 P:\2022\175.OL.R-4705-Traffic\Signing and Delineation\Pavement Markings\Sheets\R-4705\_PMP-08.dgn  
 User: AH01es

TIP NO.	SHEET NO.
R-4705	PMP-09
APPROVED: 	
DATE: 4/7/2022	
SEAL	
	
DOCUMENT NOT CONSIDERED FINAL UNLESS ALL SIGNATURES COMPLETED	

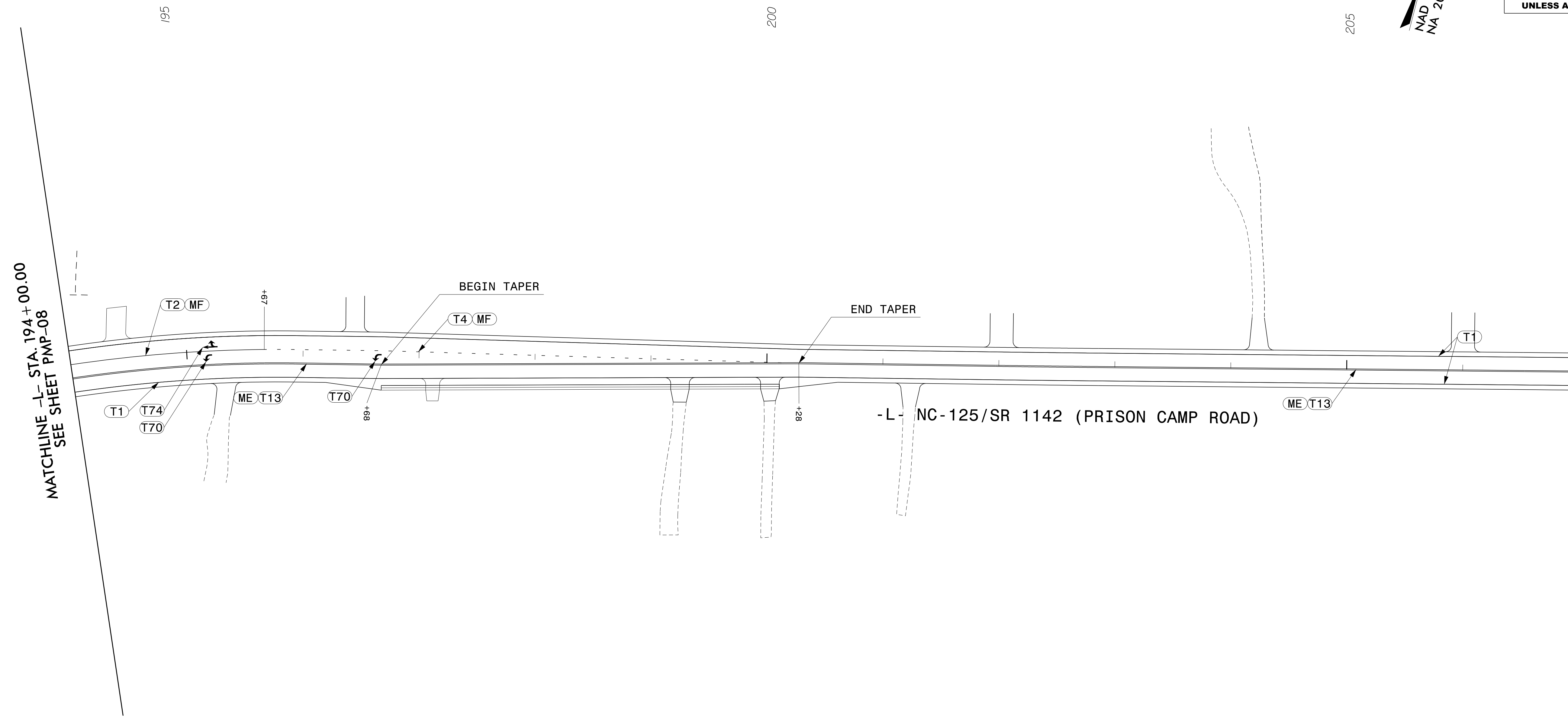
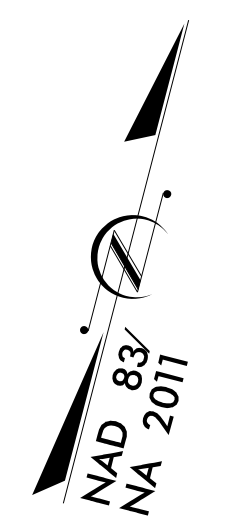

MATCHLINE -L- STA. 194+00.00  
SEE SHEET PMP-08

MATCHLINE -L- STA. 207+00.00  
SEE SHEET PMP-10

-L- NC-125/SR 1142 (PRISON CAMP ROAD)



3/11/2022  
P:\2022\175.OLR-4705-Find\Traffic\Signing and Delineation\Pavement Markings\Sheets\R-4705\_PMP\_09.dgn  
User: AH01es

**ETHERILL ENGINEERING**  
 1223 Jones Franklin Rd.  
 Raleigh, N.C. 27606  
 License No. F-0377  
 Bus: 919 851 8077  
 Fax: 919 851 8107

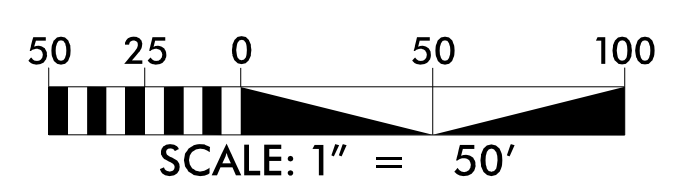
TRANSPORTATION PLANNING/DESIGN - BRIDGE/STRUCTURE DESIGN  
 CIVIL/SITE DESIGN - GIS/GPS - CONSTRUCTION OBSERVATION

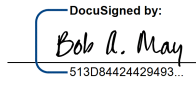

PAVEMENT MARKING PLAN SHEET

TIP NO.	SHEET NO.
R-4705	PMP-10
APPROVED: 	
DATE: 4/7/2022	
SEAL	
	
DOCUMENT NOT CONSIDERED FINAL UNLESS ALL SIGNATURES COMPLETED	

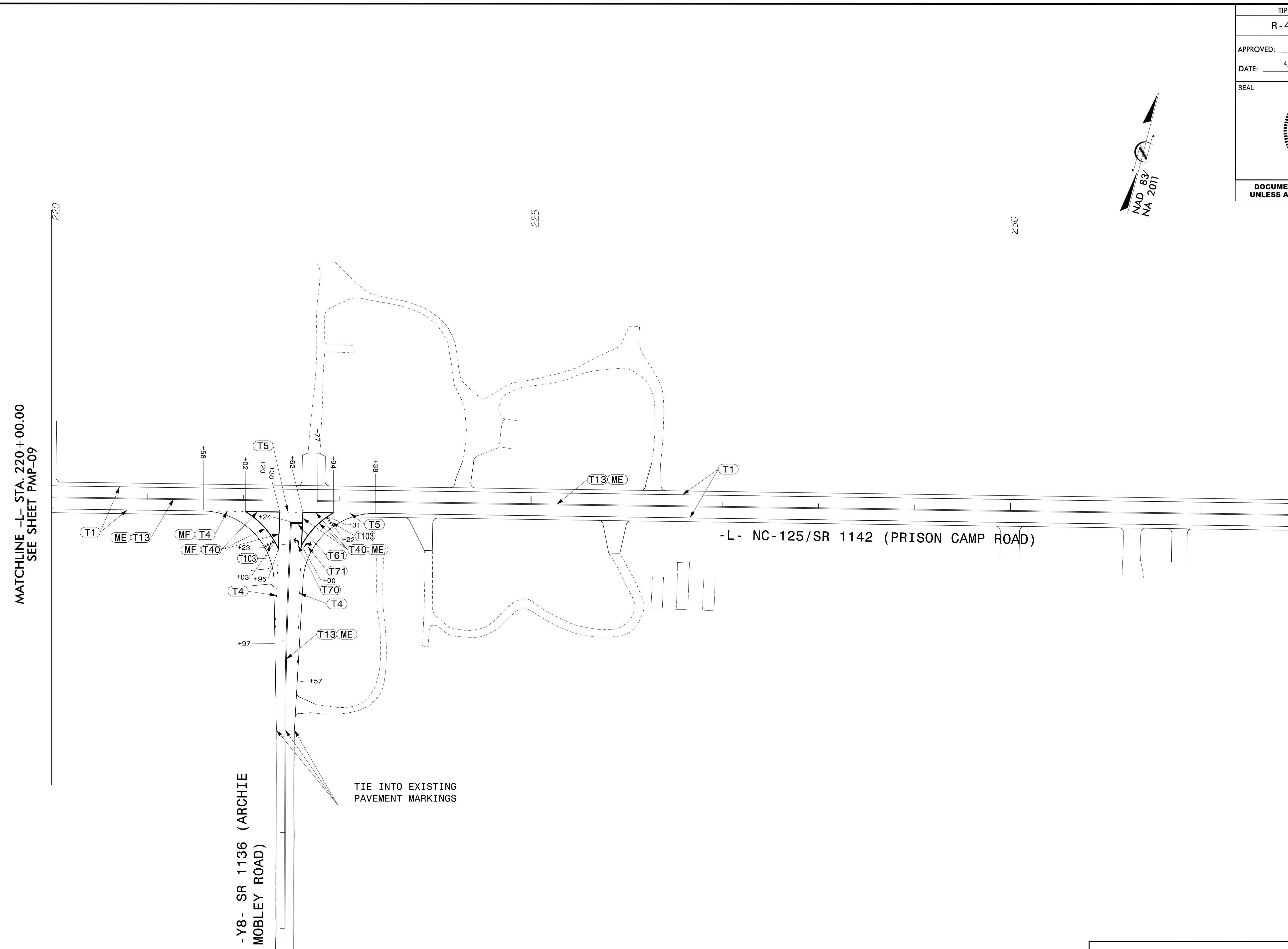
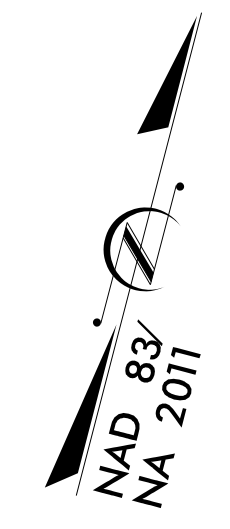

MATCHLINE -L- STA. 220 + 00.00  
SEE SHEET PMP-09

BREAKLINE -L- STA. 233 + 00.00  
SEE SHEET PMP-11

-L- NC-125/SR 1142 (PRISON CAMP ROAD)

-Y8- SR 1136 (ARCHIE  
MOBLEY ROAD)

TIE INTO EXISTING  
PAVEMENT MARKINGS

3/11/2022  
 P:\2022\17175.01.R-4705-Find\Traffic\Signing and Delineation\Pavement Markings\Sheets\R-4705\_PMP\_10.dgn  
 User: AH01e5

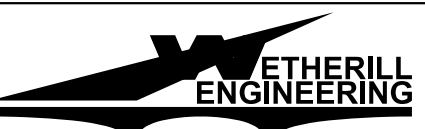

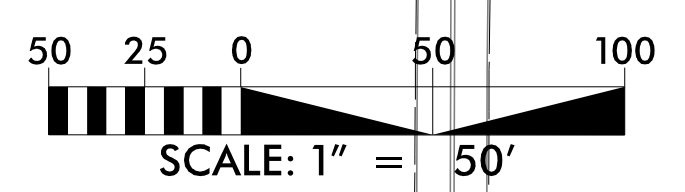

1223 Jones Franklin Rd.  
 Raleigh, N.C. 27606  
 License No. F-0377  
 Bus: 919 851 8077  
 Fax: 919 851 8107

TRANSPORTATION PLANNING/DESIGN - BRIDGE/STRUCTURE DESIGN  
 CIVIL/SITE DESIGN - GIS/GPS - CONSTRUCTION OBSERVATION

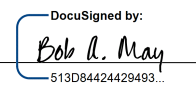

PAVEMENT MARKING PLAN SHEET

TIP NO. R-4705	SHEET NO. PMP-11
APPROVED:  DATE: 4/7/2022	
SEAL 	
DOCUMENT NOT CONSIDERED FINAL UNLESS ALL SIGNATURES COMPLETED	

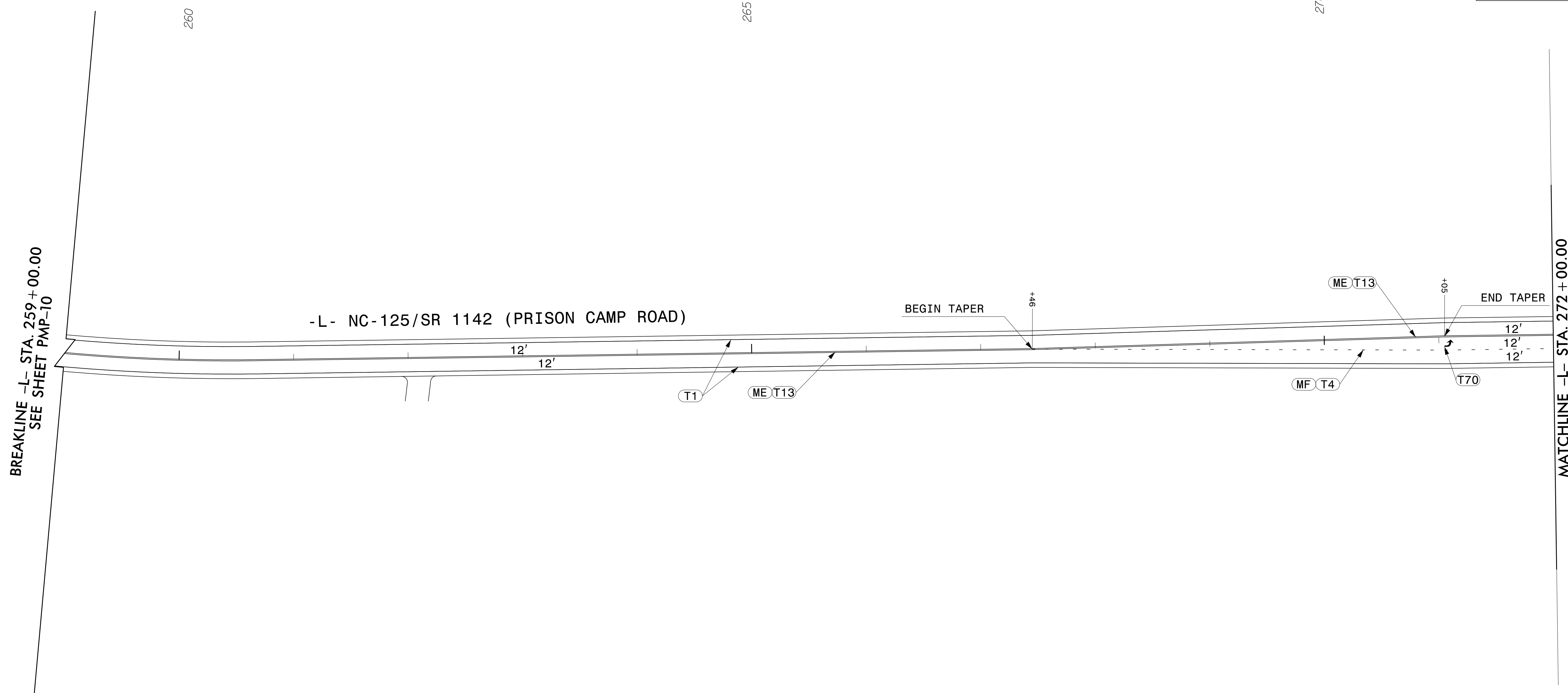
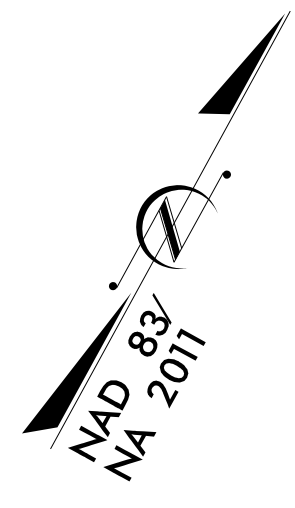

BREAKLINE -L- STA. 259+00.00  
SEE SHEET PMP-10

MATCHLINE -L- STA. 272+00.00  
SEE SHEET PMP-12

3/11/2022  
P:\2022\175.OLR-4705-Find\Traffic\Signing and Delineation\Pavement Markings\Sheets\R-4705\_PMP\_11.dgn  
User: AH01es

**ETHERILL ENGINEERING**  
 1223 Jones Franklin Rd.  
 Raleigh, N.C. 27606  
 License No. F-0377  
 Bus: 919 851 8077  
 Fax: 919 851 8107

TRANSPORTATION PLANNING/DESIGN - BRIDGE/STRUCTURE DESIGN  
 CIVIL/SITE DESIGN - GIS/GPS - CONSTRUCTION OBSERVATION

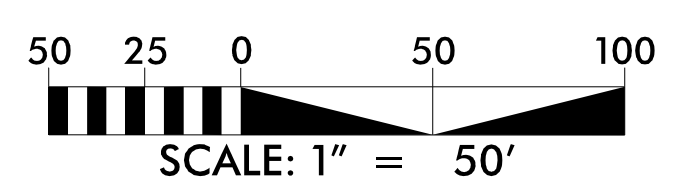

**PAVEMENT MARKING PLAN SHEET**

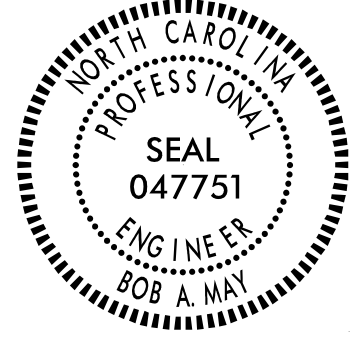
TIP NO. R-4705	SHEET NO. PMP-12
APPROVED: <i>Bob A. May</i> DATE: 4/7/2022	
SEAL 	
DOCUMENT NOT CONSIDERED FINAL UNLESS ALL SIGNATURES COMPLETED	

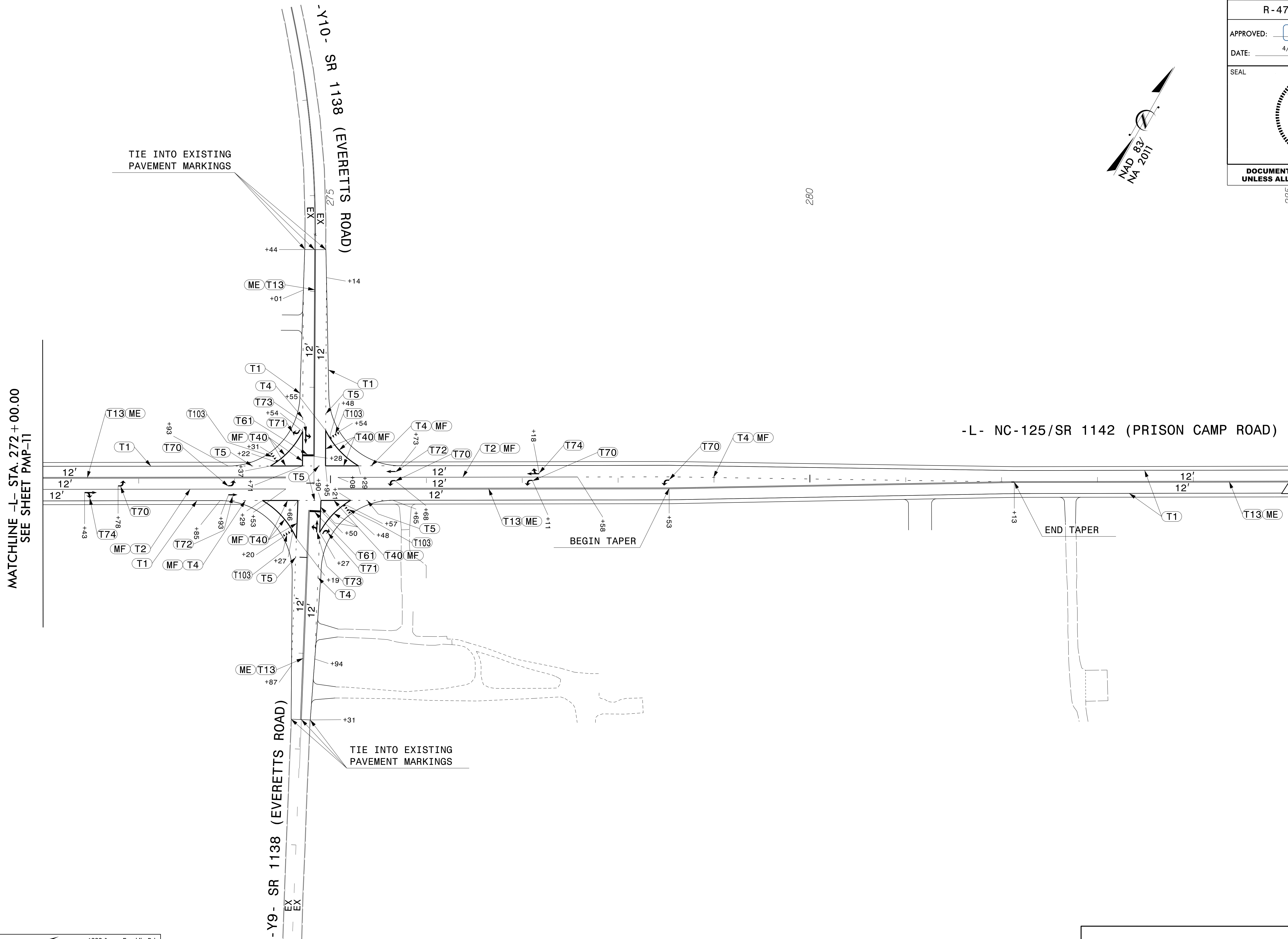
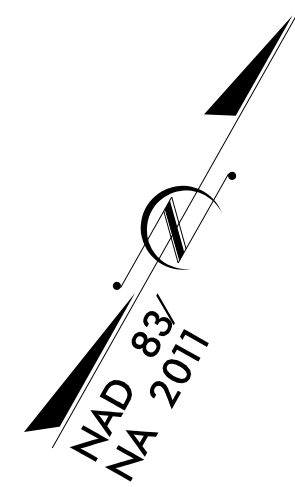

MATCHLINE -L- STA. 272+00.00  
SEE SHEET PMP-11

BREAKLINE -L- STA. 285+00.00  
SEE SHEET PMP-13

3/11/2022  
P:\2022\175.OL-R-4705-Traffic\Signing and Delineation\Pavement Markings\Sheets\R-4705\_PMP\_12.dgn  
User: AH01es

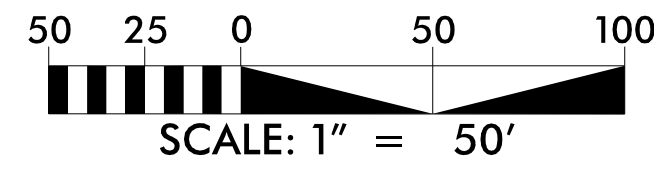

**ETHERILL ENGINEERING**  
 1223 Jones Franklin Rd.  
 Raleigh, N.C. 27606  
 License No. F-0377  
 Bus: 919 851 8077  
 Fax: 919 851 8107

TRANSPORTATION PLANNING/DESIGN - BRIDGE/STRUCTURE DESIGN  
 CIVIL/SITE DESIGN - GIS/GPS - CONSTRUCTION OBSERVATION



**PAVEMENT MARKING PLAN SHEET**

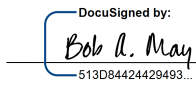

TIP NO.	SHEET NO.
R-4705	PMP-14
APPROVED: 	
DATE: 4/7/2022	
SEAL	
	
DOCUMENT NOT CONSIDERED FINAL UNLESS ALL SIGNATURES COMPLETED	

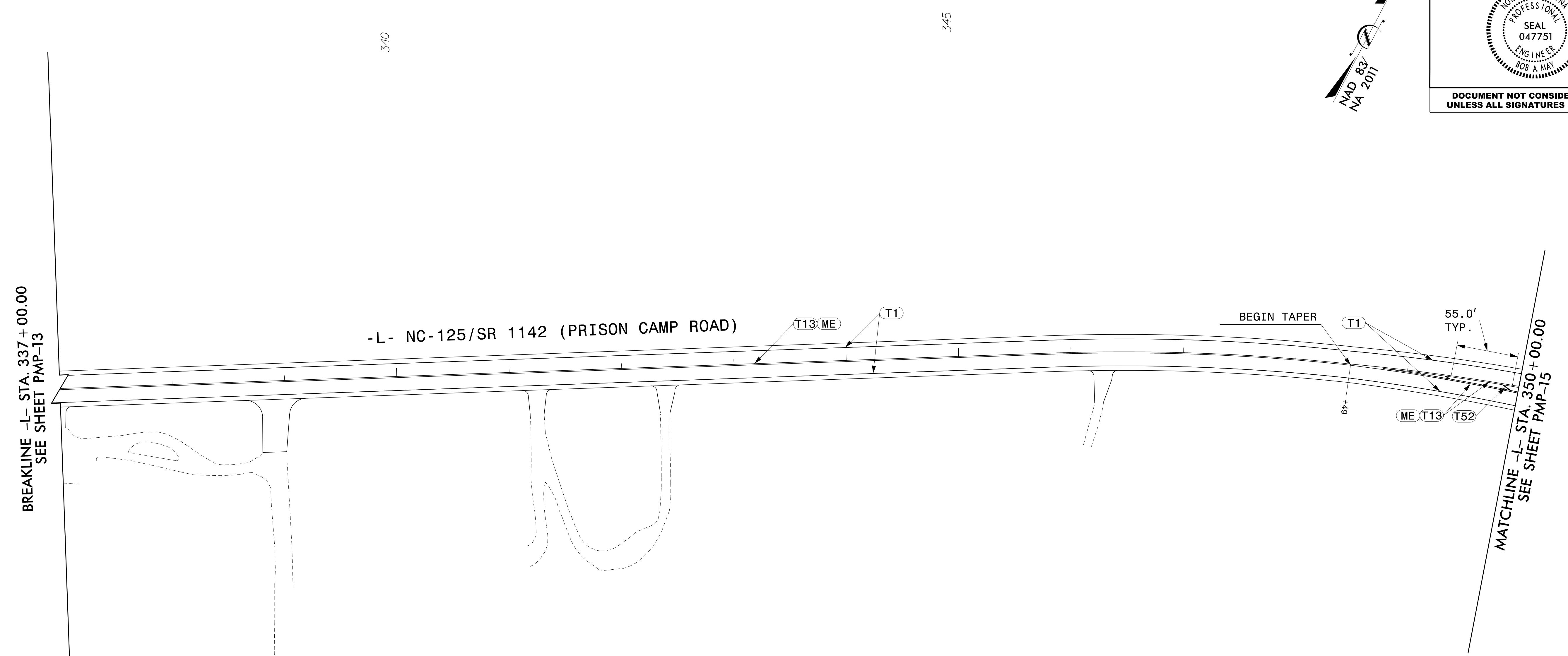
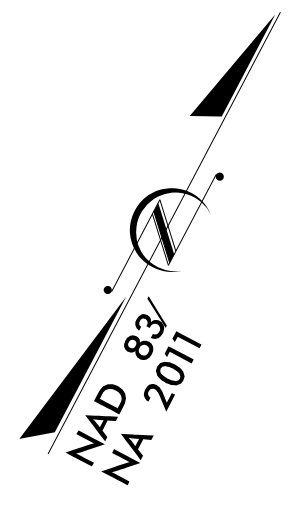

3/11/2022  
 P:\2022\17175.01.R-4705-Find\Traffic\Signing and Delineation\Pavement Markings\Sheets\R-4705\_PMP\_14.dgn  
 User: AH01es



1223 Jones Franklin Rd.  
 Raleigh, N.C. 27606  
 License No. F-0377  
 Bus: 919 851 8077  
 Fax: 919 851 8107

TRANSPORTATION PLANNING/DESIGN - BRIDGE/STRUCTURE DESIGN  
 CIVIL/SITE DESIGN - GIS/GPS - CONSTRUCTION OBSERVATION

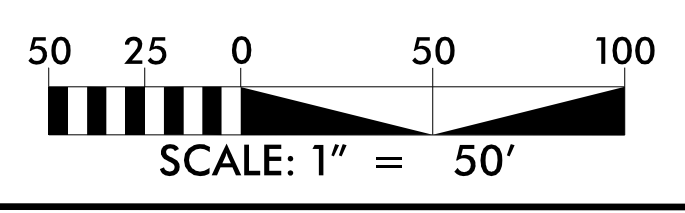

**PAVEMENT MARKING PLAN SHEET**

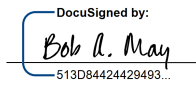
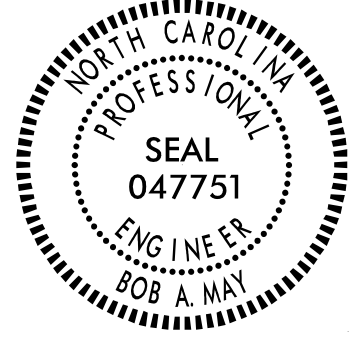

TIP NO.	SHEET NO.
R-4705	PMP-15
APPROVED: 	
DATE: 4/7/2022	
SEAL	
	
DOCUMENT NOT CONSIDERED FINAL UNLESS ALL SIGNATURES COMPLETED	

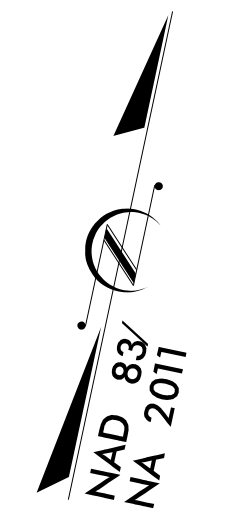

350  
SEE SHEET PMP-14  
MATCHLINE -L- STA. 350 +00.00

360  
MATCHLINE -L- STA. 363 +00.00  
SEE SHEET PMP-16

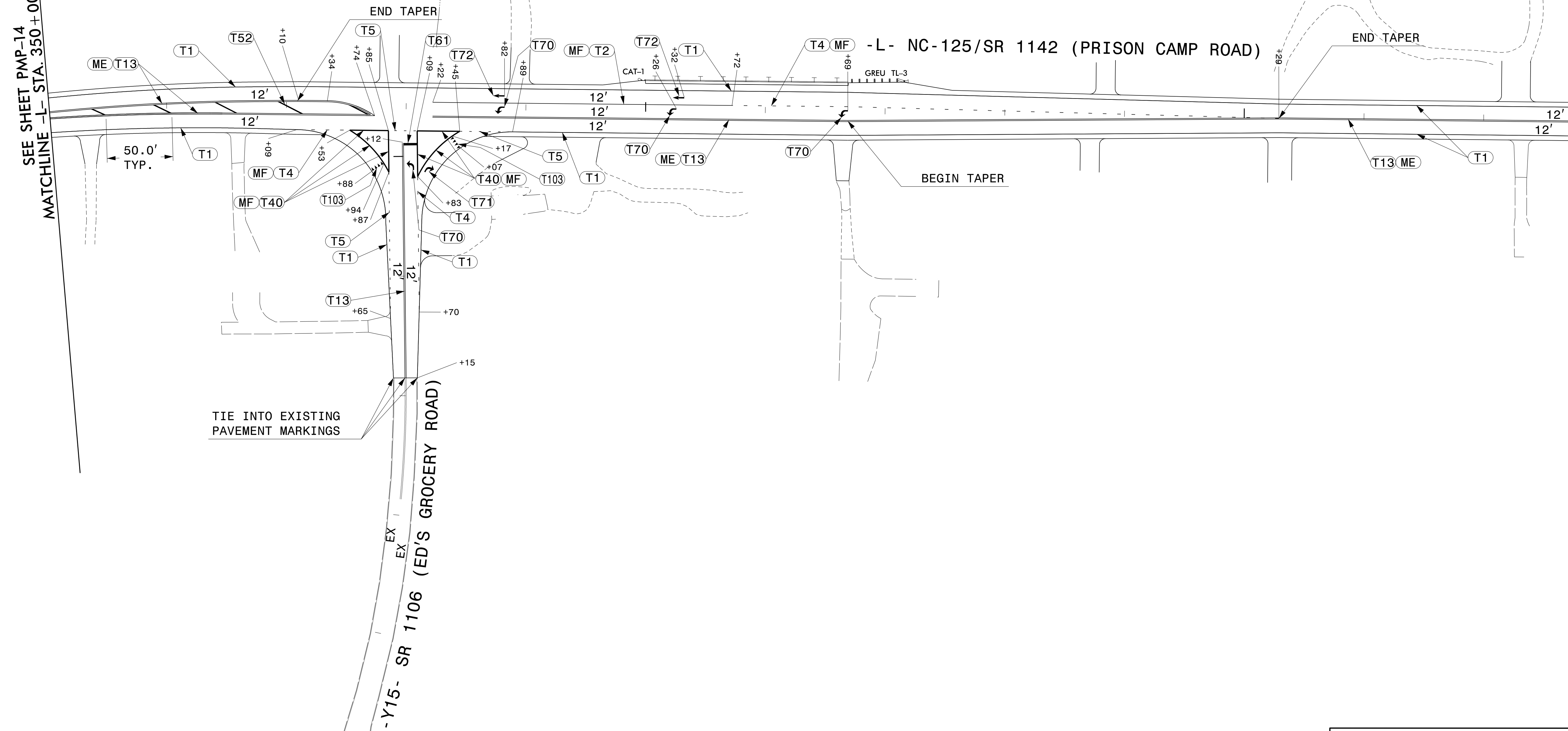

TIE INTO EXISTING  
PAVEMENT MARKINGS

-Y15- SR 1106 (ED'S GROCERY ROAD)

-L- NC-125/SR 1142 (PRISON CAMP ROAD)

**ETHERILL ENGINEERING**  
 1223 Jones Franklin Rd.  
 Raleigh, N.C. 27606  
 License No. F-0377  
 Bus: 919 851 8077  
 Fax: 919 851 8107

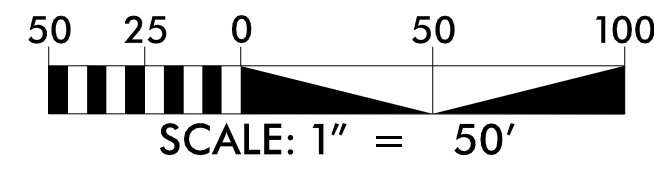

TRANSPORTATION PLANNING/DESIGN - BRIDGE/STRUCTURE DESIGN  
 CIVIL/SITE DESIGN - GIS/GPS - CONSTRUCTION OBSERVATION



**PAVEMENT MARKING PLAN SHEET**

3/11/2022  
 P:\2022\17175.01.R-4705-Find\Traffic\Signing and Delineation\Pavement Markings\Sheets\R-4705\_PMP\_15.dgn  
 User: AH01es

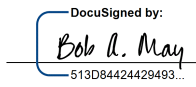

TIP NO. R-4705	SHEET NO. PMP-17
APPROVED:  DATE: 4/7/2022	
SEAL 	
DOCUMENT NOT CONSIDERED FINAL UNLESS ALL SIGNATURES COMPLETED	

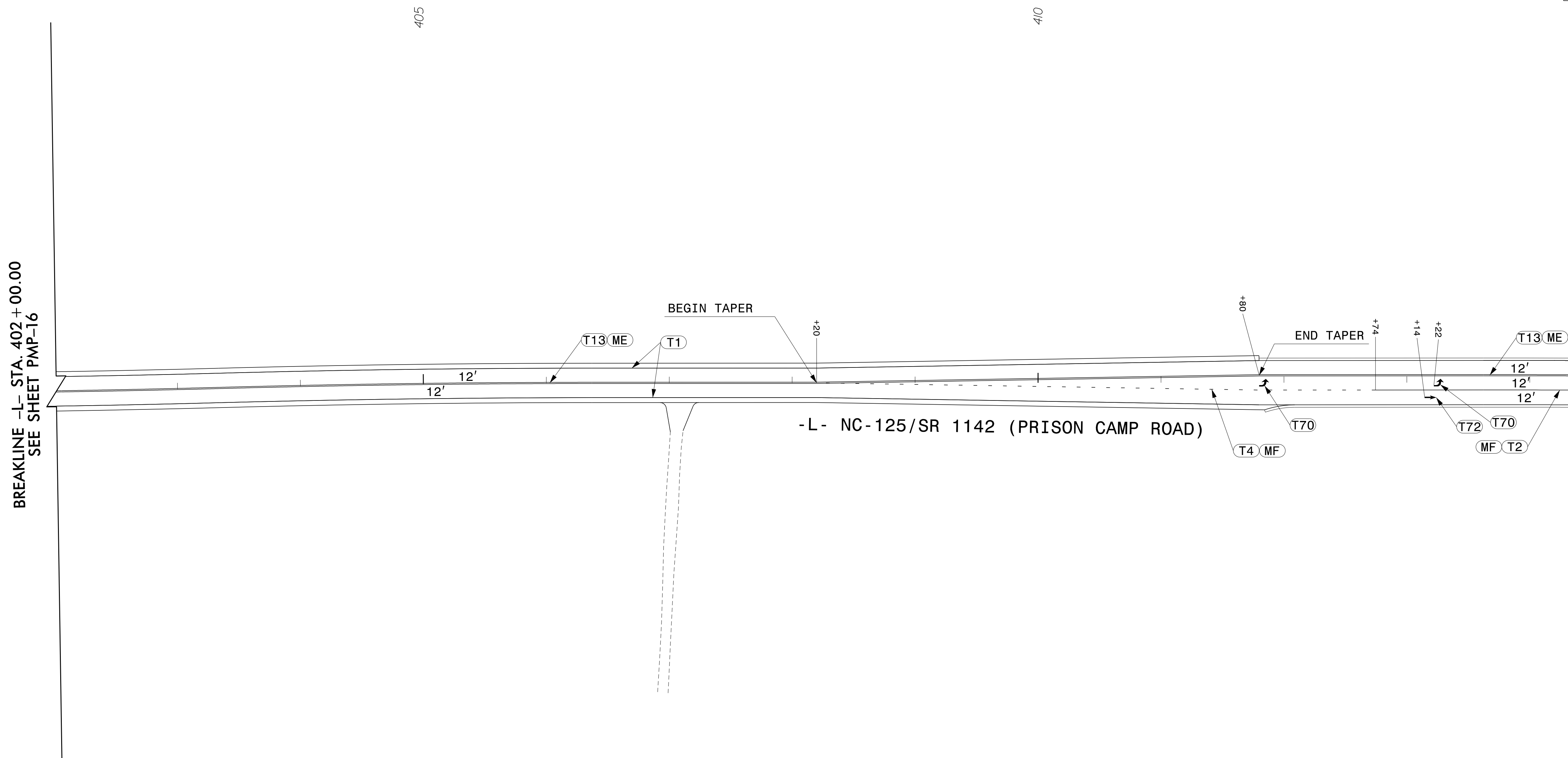



3/11/2022  
P:\2022\175.OLR-4705-Find\Traffic\Signing and Delineation\Pavement Markings\Sheets\R-4705\_PMP\_17.dgn  
User: AH01es

**ETHERILL ENGINEERING**  
 1223 Jones Franklin Rd.  
 Raleigh, N.C. 27606  
 License No. F-0377  
 Bus: 919 851 8077  
 Fax: 919 851 8107

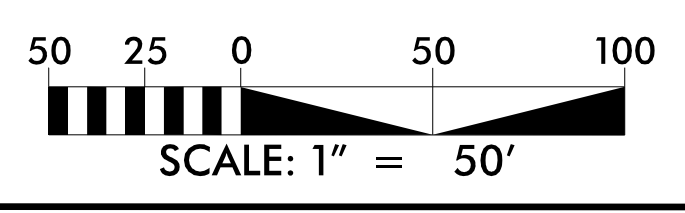
TRANSPORTATION PLANNING/DESIGN - BRIDGE/STRUCTURE DESIGN  
 CIVIL/SITE DESIGN - GIS/GPS - CONSTRUCTION OBSERVATION

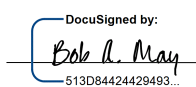

**PAVEMENT MARKING PLAN SHEET**

TIP NO. R-4705	SHEET NO. PMP-18
APPROVED:  DATE: 4/7/2022	
SEAL 	
DOCUMENT NOT CONSIDERED FINAL UNLESS ALL SIGNATURES COMPLETED	

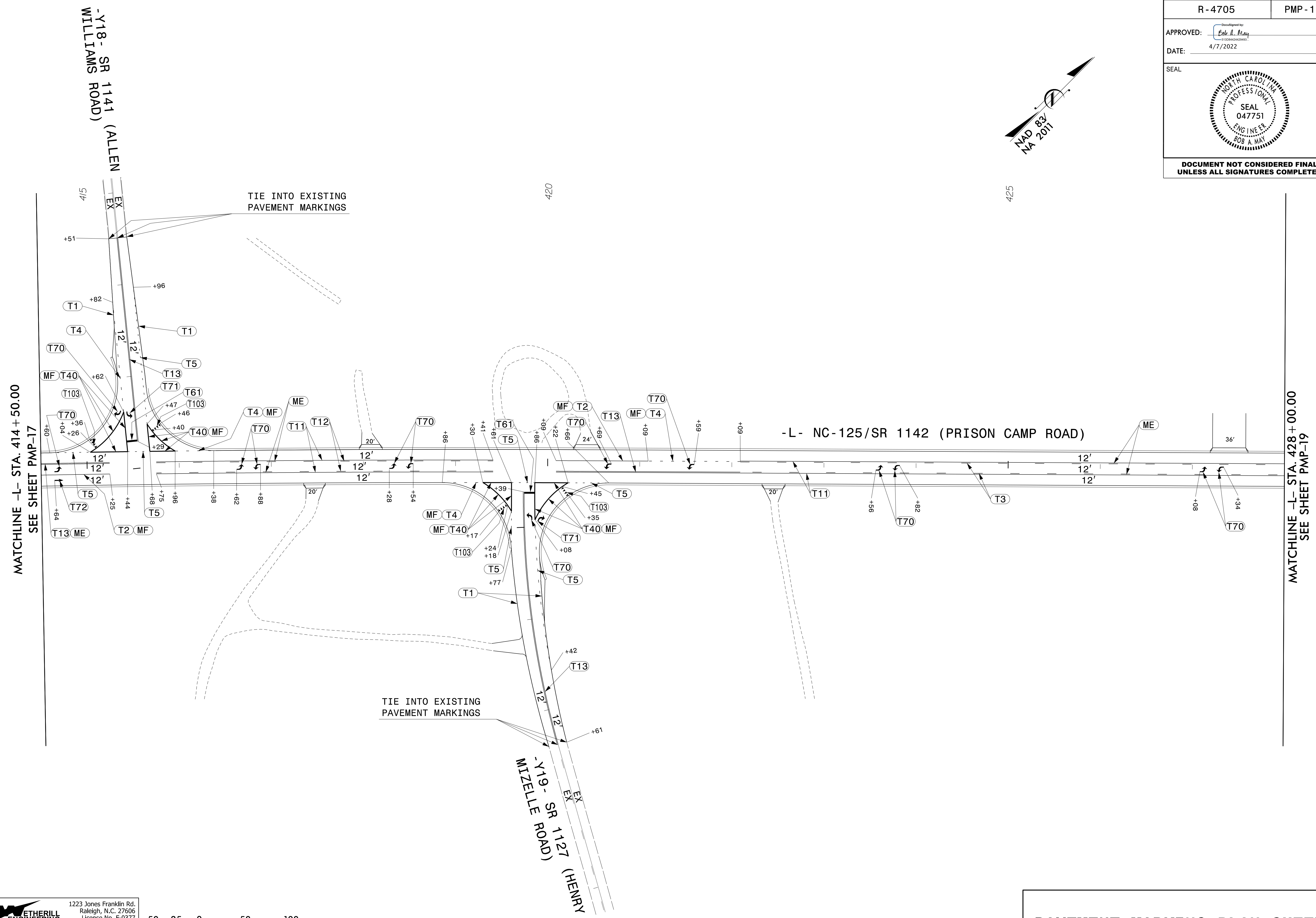
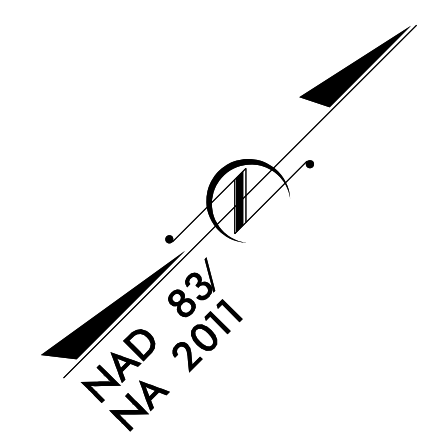

MATCHLINE -L- STA. 414 + 50.00  
SEE SHEET PMP-17

MATCHLINE -L- STA. 428 + 00.00  
SEE SHEET PMP-19

**ETHERILL ENGINEERING**  
 1223 Jones Franklin Rd.  
 Raleigh, N.C. 27606  
 License No. F-0377  
 Bus: 919 851 8077  
 Fax: 919 851 8107

TRANSPORTATION PLANNING/DESIGN - BRIDGE/STRUCTURE DESIGN  
 CIVIL/SITE DESIGN - GIS/GPS - CONSTRUCTION OBSERVATION

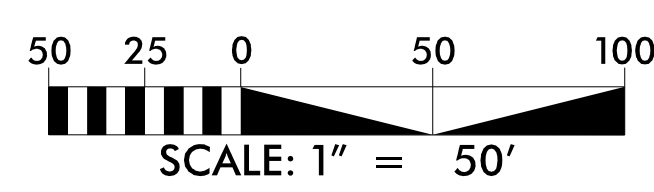

**PAVEMENT MARKING PLAN SHEET**

3/11/2022  
 P:\2022\17175.01.R-4705-Find\Traffic\Signing and Delineation\Pavement Markings\Sheets\R-4705\_PMP-18.dgn  
 User: AH01es

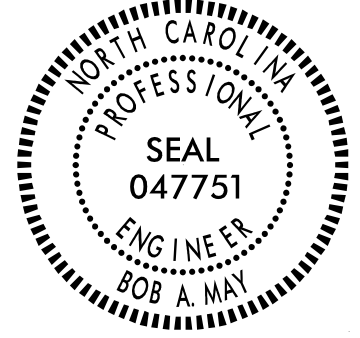

TIP NO. R-4705	SHEET NO. PMP-20
APPROVED: <i>Bob A. May</i> DATE: 4/7/2022	
SEAL 	
DOCUMENT NOT CONSIDERED FINAL UNLESS ALL SIGNATURES COMPLETED	

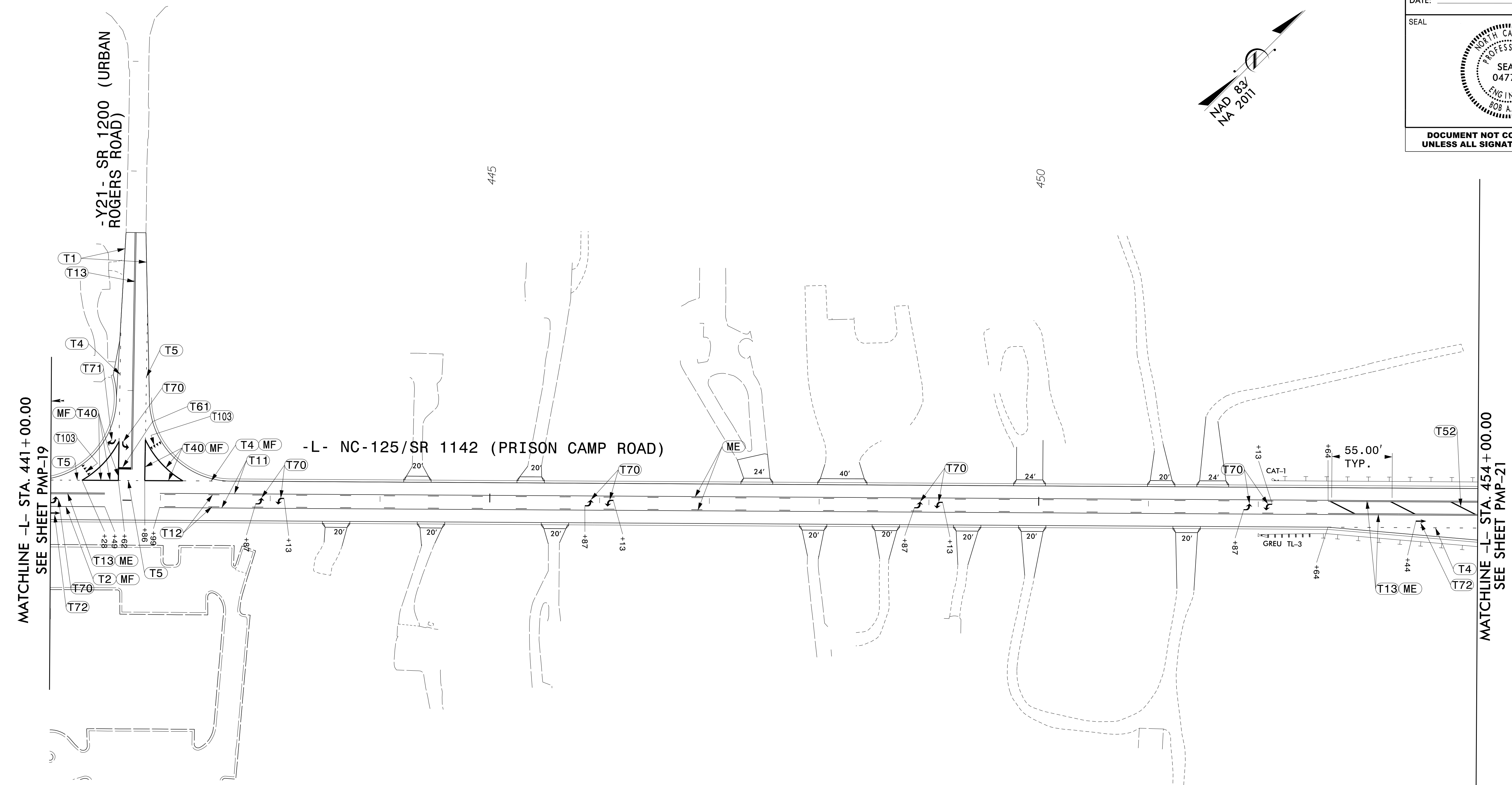
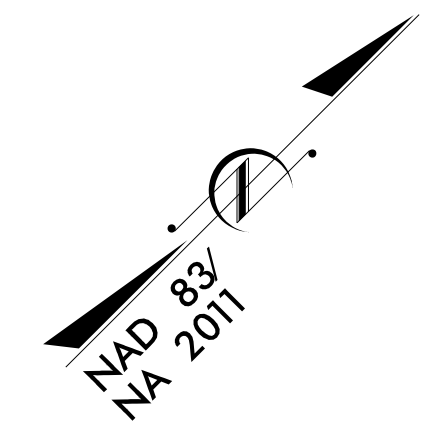

3/11/2022  
 P:\2022\175.OL.R-4705-Find\Traffic\Signing and Delineation\Pavement Markings\Sheets\R-4705-PMP-20.dgn  
 User: AH01es

**ETHERILL ENGINEERING**  
 1223 Jones Franklin Rd.  
 Raleigh, N.C. 27606  
 License No. F-0377  
 Bus: 919 851 8077  
 Fax: 919 851 8107  
 TRANSPORTATION PLANNING/DESIGN - BRIDGE/STRUCTURE DESIGN  
 CIVIL/SITE DESIGN - GIS/GPS - CONSTRUCTION OBSERVATION

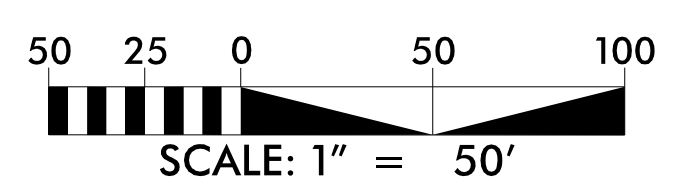

**PAVEMENT MARKING PLAN SHEET**

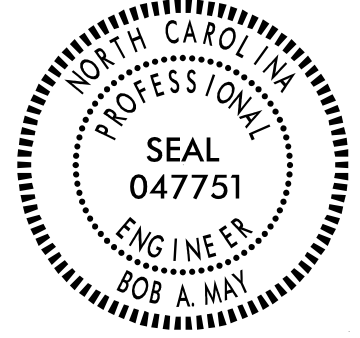
TIP NO. R-4705	SHEET NO. PMP-21
APPROVED: <i>Paul H. May</i> 4/7/2022	
DATE: 4/7/2022	
SEAL 	
DOCUMENT NOT CONSIDERED FINAL UNLESS ALL SIGNATURES COMPLETED	

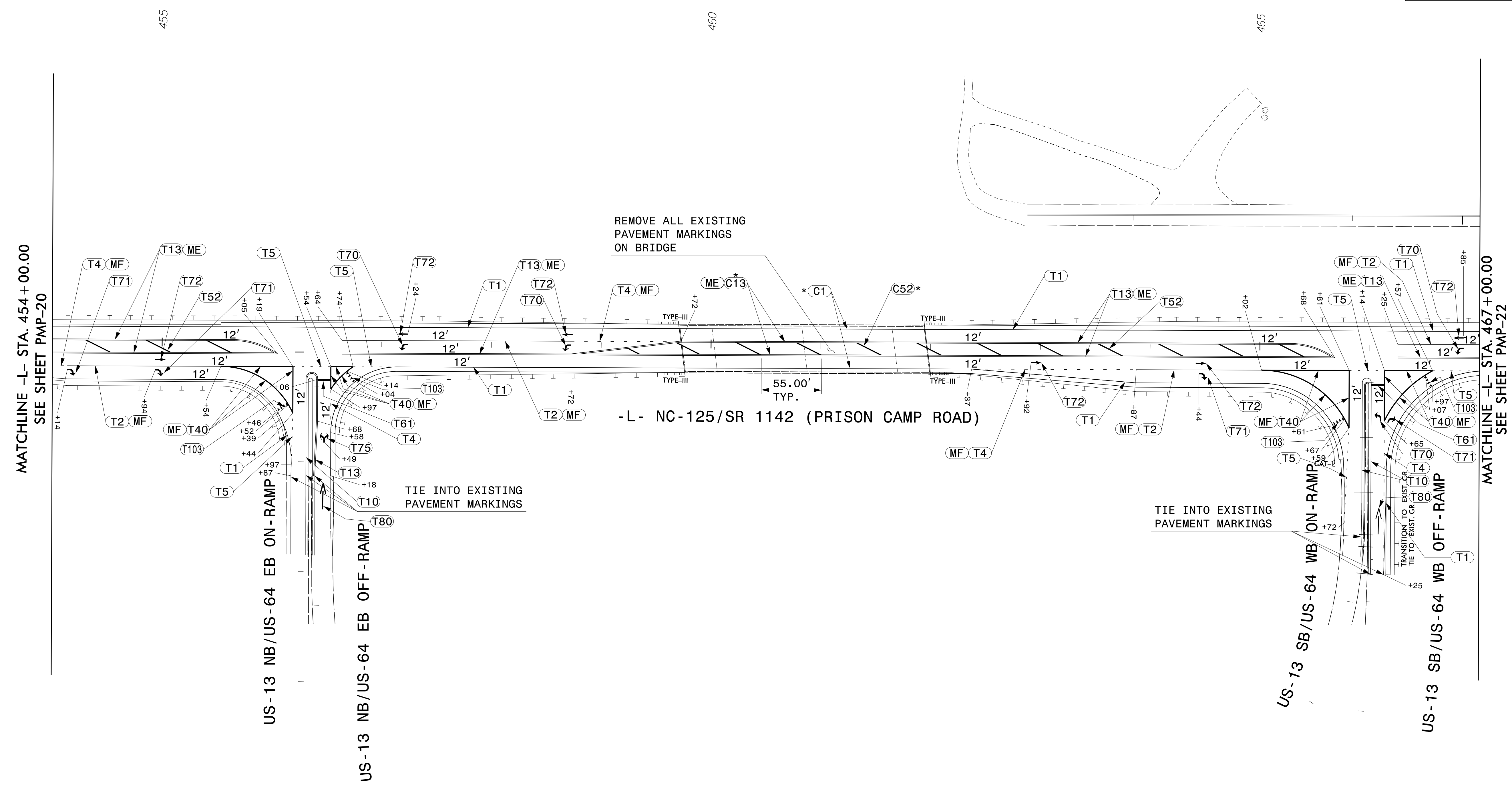

3/11/2022  
 P:\2022\175.01.R-4705-Traffic\Signing and Delineation\Pavement Markings\Sheets\R-4705\_PMP\_21.dgn  
 User:AH01es

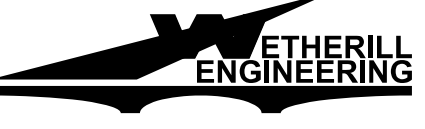
 1223 Jones Franklin Rd.  
 Raleigh, N.C. 27606  
 License No. F-0377  
 Bus: 919 851 8077  
 Fax: 919 851 8107

TRANSPORTATION PLANNING/DESIGN - BRIDGE/STRUCTURE DESIGN  
 CIVIL/SITE DESIGN - GIS/GPS - CONSTRUCTION OBSERVATION

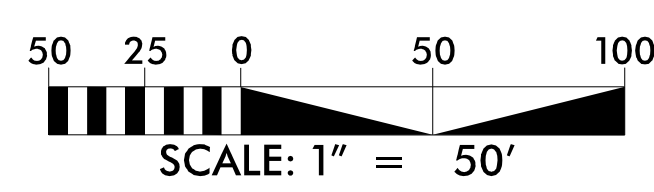

\* UTILIZE TYPE 2 COLD APPLIED PLASTIC PAVEMENT MARKINGS WITH 2" BLACK BORDER.

**PAVEMENT MARKING PLAN SHEET**

TIP NO.	SHEET NO.
R-4705	PMP-22
APPROVED: <i>Bob A. May</i>	
DATE: 4/7/2022	
SEAL	
DOCUMENT NOT CONSIDERED FINAL UNLESS ALL SIGNATURES COMPLETED	

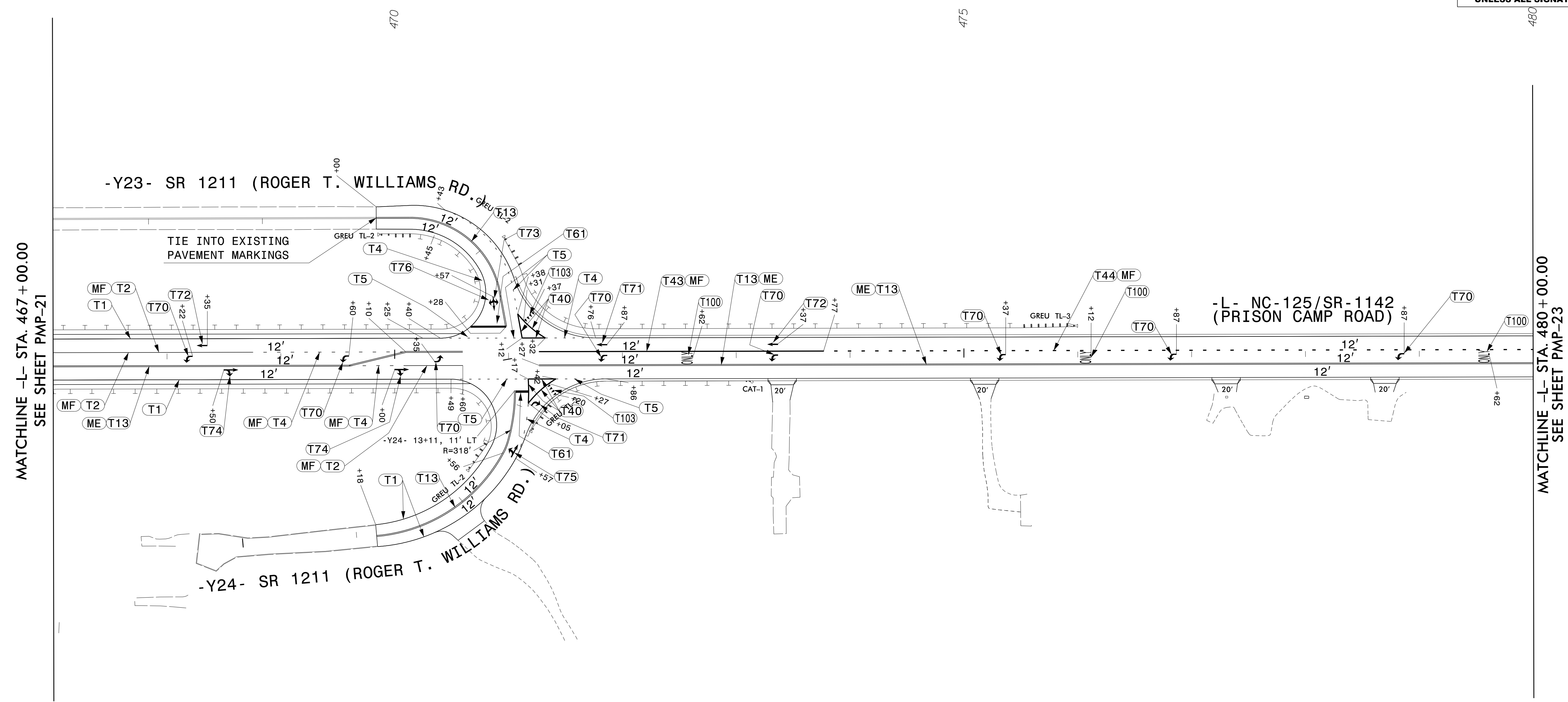
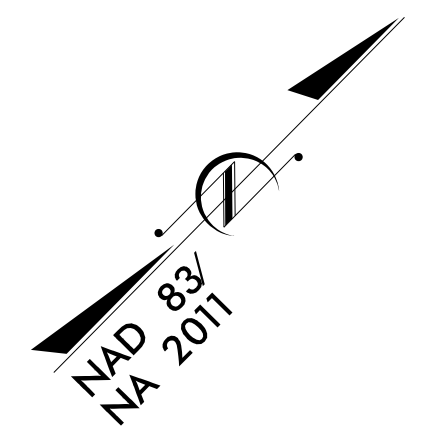

MATCHLINE -L- STA. 467+00.00  
SEE SHEET PMP-21

MATCHLINE -L- STA. 480+00.00  
SEE SHEET PMP-23

3/11/2022  
 P:\2022\175.OLR-4705-Find\Traffic\Signing and Delineation\Pavement Markings\Sheets\R-4705\_PMP\_22.dgn  
 User: AH01es

1223 Jones Franklin Rd.  
 Raleigh, N.C. 27606  
 License No. F-0377  
 Bus: 919 851 8077  
 Fax: 919 851 8107

TRANSPORTATION PLANNING/DESIGN - BRIDGE/STRUCTURE DESIGN  
 CIVIL/SITE DESIGN - GIS/GPS - CONSTRUCTION OBSERVATION

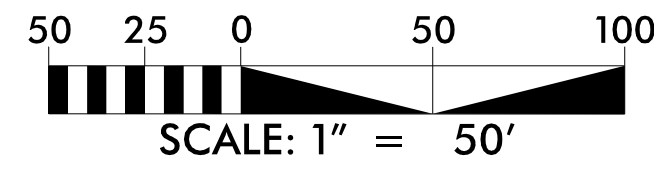

**PAVEMENT MARKING PLAN SHEET**

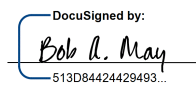
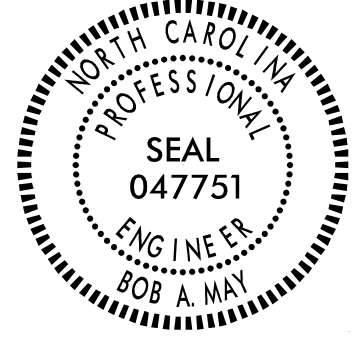

TIP NO. <b>R-4705</b>	SHEET NO. <b>PMP-23</b>
APPROVED:  4/7/2022	
DATE: 4/7/2022	
SEAL 	
DOCUMENT NOT CONSIDERED FINAL UNLESS ALL SIGNATURES COMPLETED	



MATCHLINE -L- STA. 480+00.00  
SEE SHEET PMP-22

MATCHLINE -L- STA. 493+00.00  
SEE SHEET PMP-24

3/11/2022 P:\2021\175.OL-R-4705-Traffic\Signing and Delineation\Pavement Markings\Sheets\R-4705\_PMP-23.dgn  
 User: AH0101

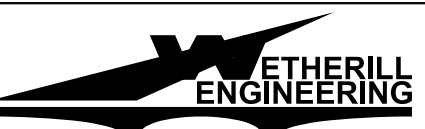

**ETHERILL ENGINEERING**  
 1223 Jones Franklin Rd.  
 Raleigh, N.C. 27606  
 License No. F-0377  
 Bus: 919 851 8077  
 Fax: 919 851 8107

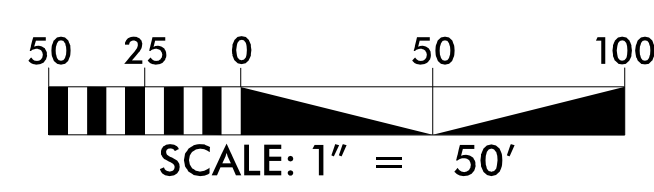
TRANSPORTATION PLANNING/DESIGN - BRIDGE/STRUCTURE DESIGN  
 CIVIL/SITE DESIGN - GIS/GPS - CONSTRUCTION OBSERVATION

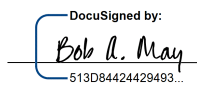
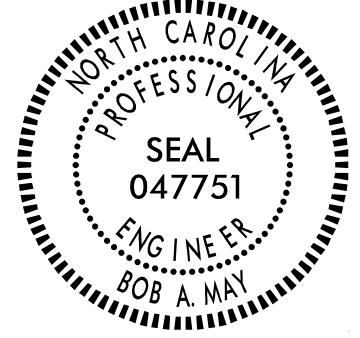

**PAVEMENT MARKING PLAN SHEET**

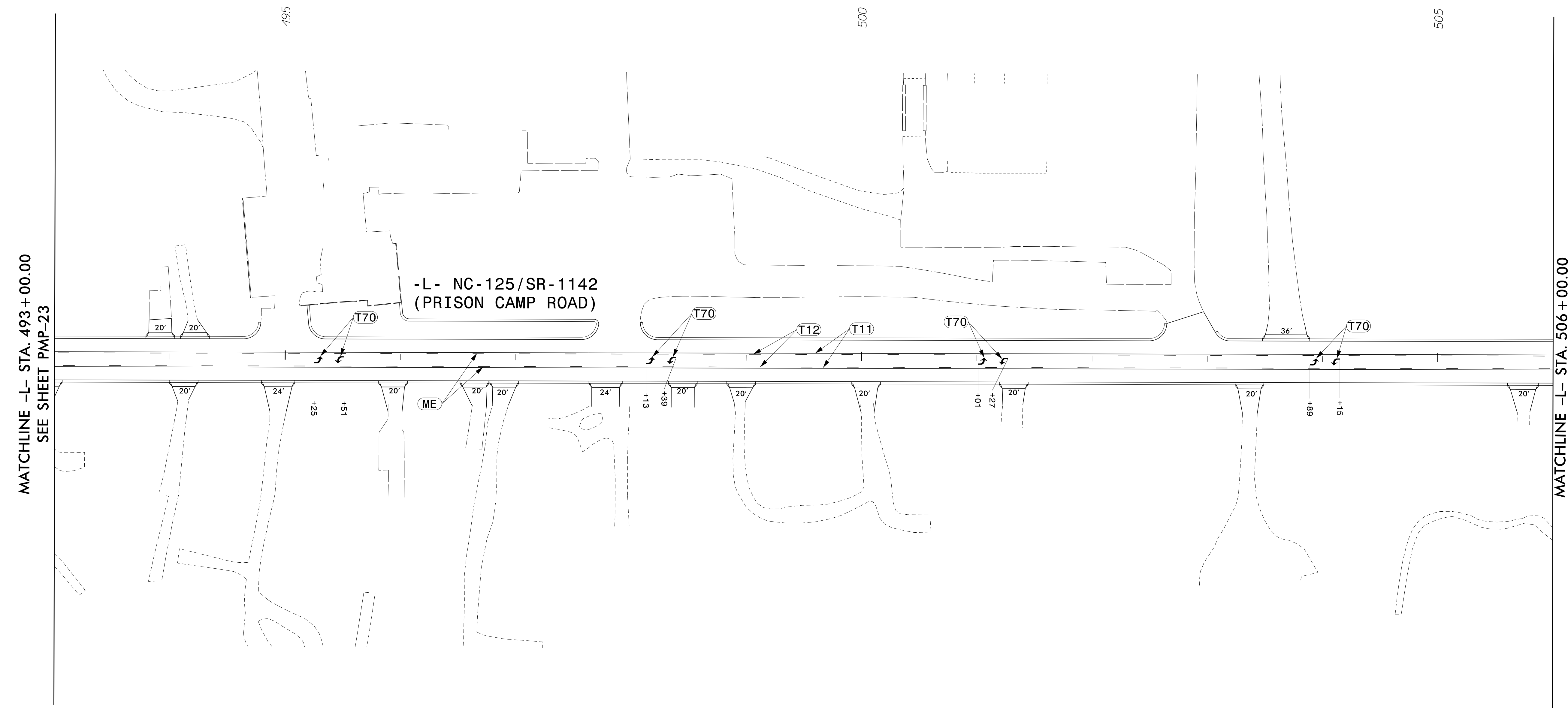
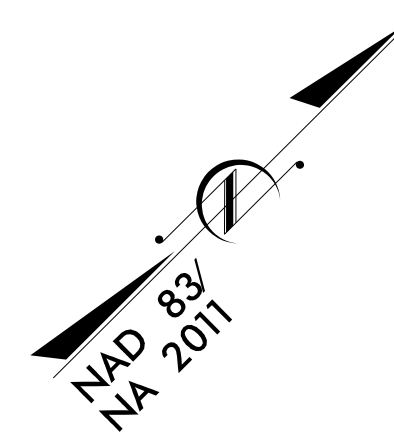
TIP NO. R-4705	SHEET NO. PMP-24
APPROVED:  DATE: 4/7/2022	
SEAL 	
DOCUMENT NOT CONSIDERED FINAL UNLESS ALL SIGNATURES COMPLETED	



MATCHLINE -L- STA. 493+00.00  
SEE SHEET PMP-23

MATCHLINE -L- STA. 506+00.00  
SEE SHEET PMP-25

-L- NC-125/SR-1142  
(PRISON CAMP ROAD)

495

500

505



1223 Jones Franklin Rd.  
Raleigh, N.C. 27606  
License No. F-0377  
Bus: 919 851 8077  
Fax: 919 851 8107

TRANSPORTATION PLANNING/DESIGN - BRIDGE/STRUCTURE DESIGN  
CIVIL/SITE DESIGN - GIS/GPS - CONSTRUCTION OBSERVATION

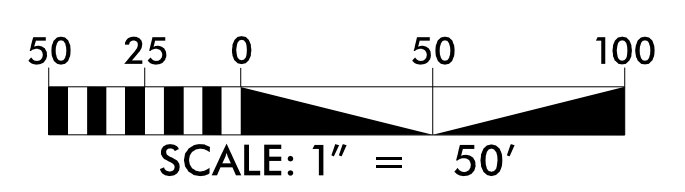

**PAVEMENT MARKING PLAN SHEET**

3/11/2022  
 P:\2022\175.OLR-4705-Find\Traffic\Signing and Delineation\Pavement Markings\Sheets\R-4705\_PMP-24.dgn  
 User: AH01es

TIP NO. R-4705	SHEET NO. PMP-25
APPROVED: <i>Bob A. May</i> <small>PROFESSIONAL ENGINEER</small>	
DATE: 4/7/2022	
SEAL 	
DOCUMENT NOT CONSIDERED FINAL UNLESS ALL SIGNATURES COMPLETED	

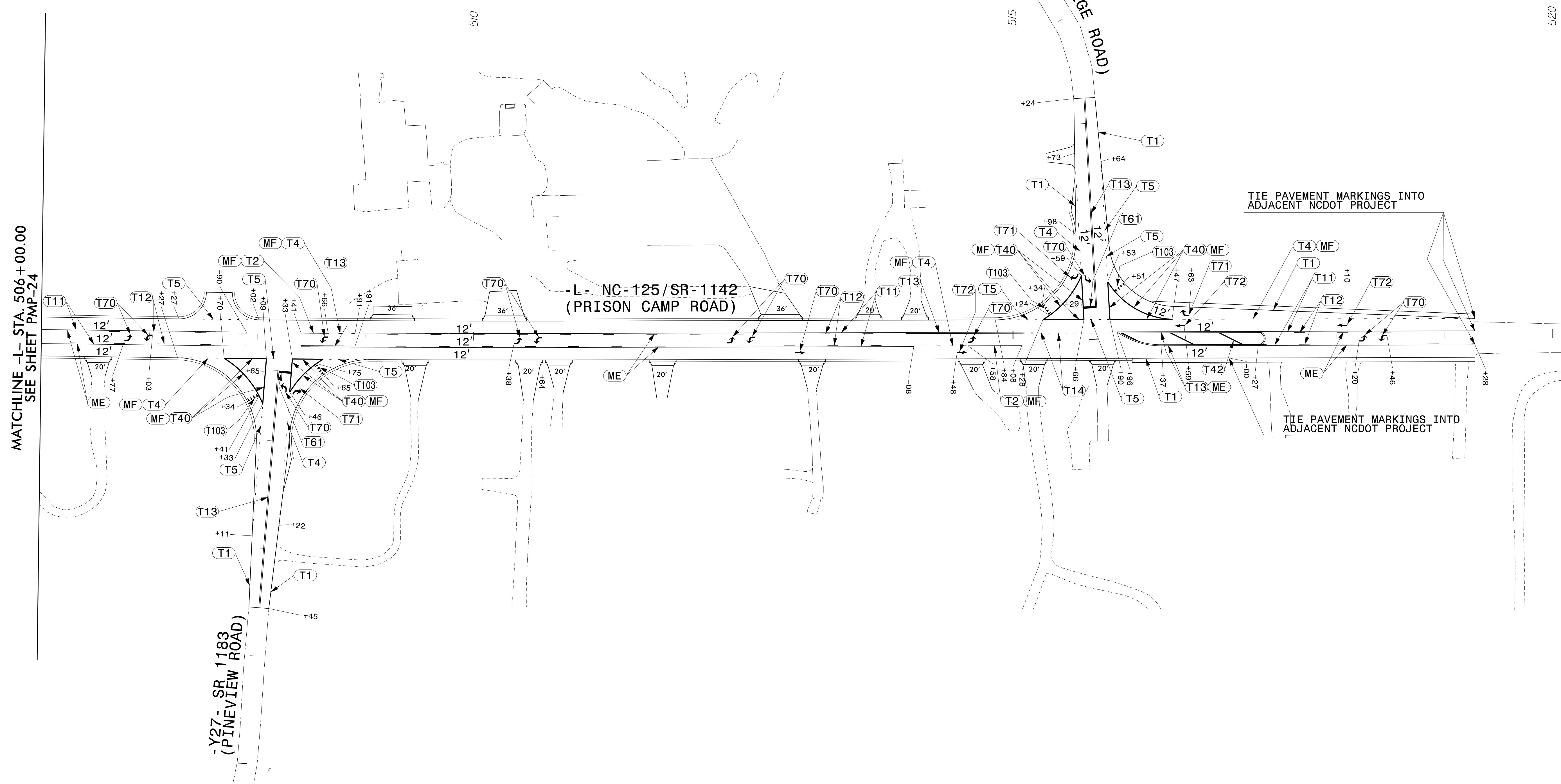

3/11/2022 10:20:17 AM C:\Users\ahoyes\Documents\Projects\4705-Prison Camp Road\Traffic\Signing and Delineation\Pavement Markings\Sheets\R-4705-PMP-25.dgn User: AHoyes

**ETHERILL ENGINEERING**  
 1223 Jones Franklin Rd.  
 Raleigh, N.C. 27606  
 License No. F-0377  
 Bus: 919 851 8077  
 Fax: 919 851 8107

TRANSPORTATION PLANNING/DESIGN - BRIDGE/STRUCTURE DESIGN  
 CIVIL/SITE DESIGN - GIS/GPS - CONSTRUCTION OBSERVATION

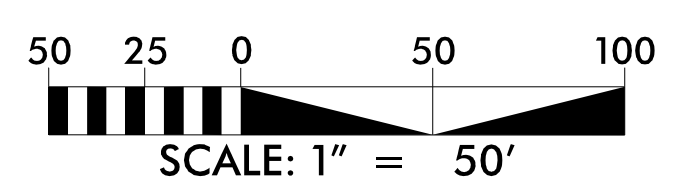

# PAVEMENT MARKING PLAN SHEET