

**This electronic collection of documents is provided
for the convenience of the user
and is Not a Certified Document –**

**The documents contained herein were originally issued
and sealed by the individuals whose names and license
numbers appear on each page, on the dates appearing
with their signature on that page.**

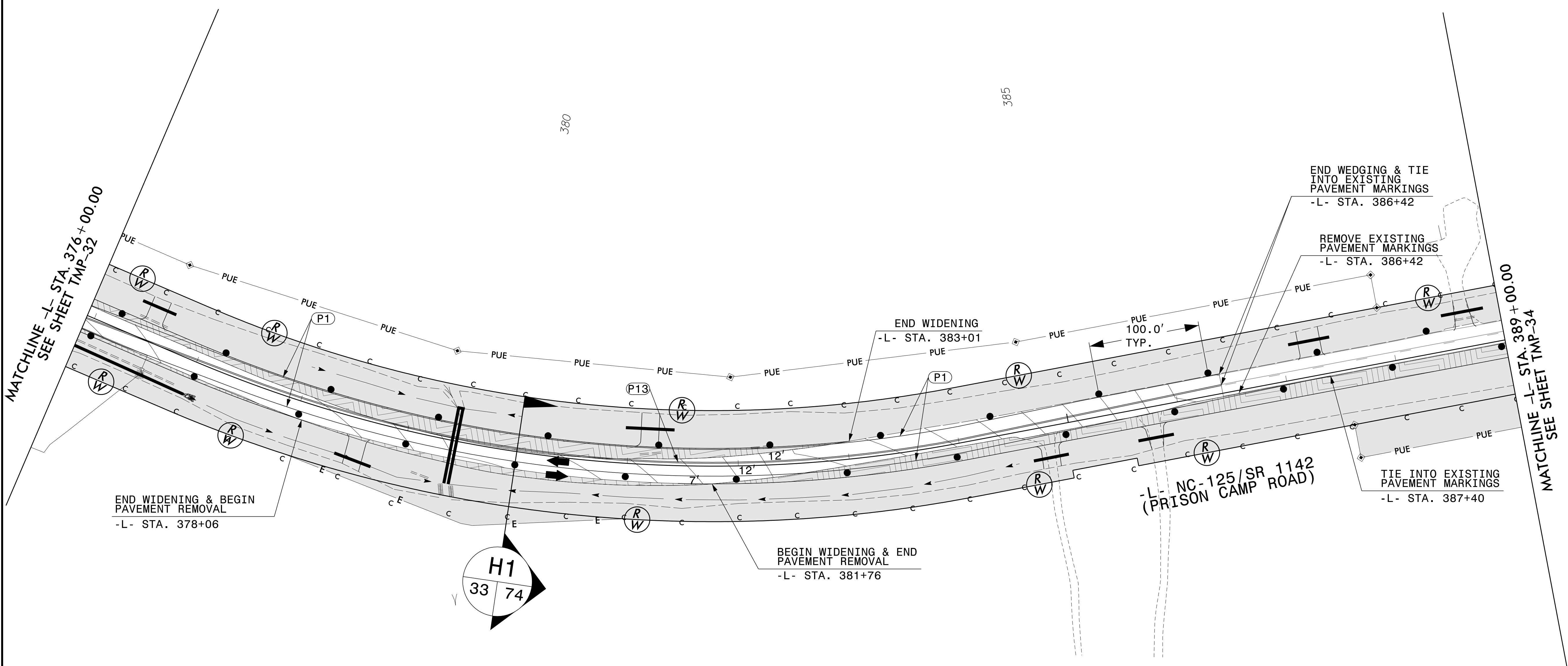

**This file or an individual page
shall not be considered a certified document.**

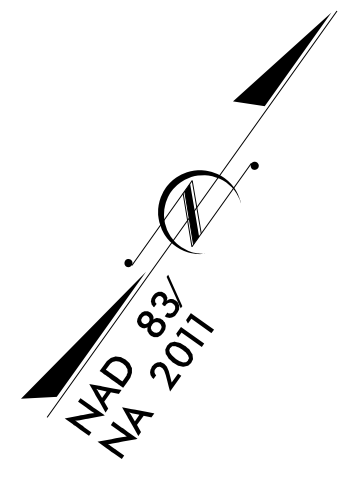

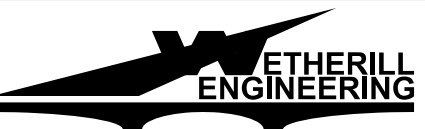
3/14/2022
 3:42:01 PM
 User: jh104
 R:\4705-Final\Traffic\WZTC\TMP\Sheets\R-4705_TC_TMP_33_P1.dgn

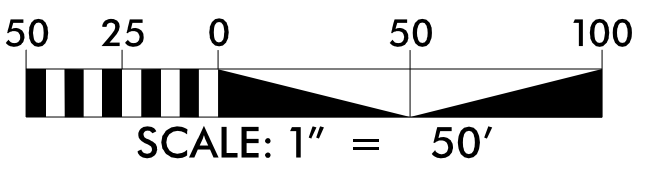

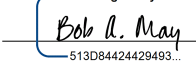
ETHERILL ENGINEERING
 1223 Jones Franklin Rd.
 Raleigh, N.C. 27606
 License No. F-0377
 Bus: 919 851 8077
 Fax: 919 851 8107

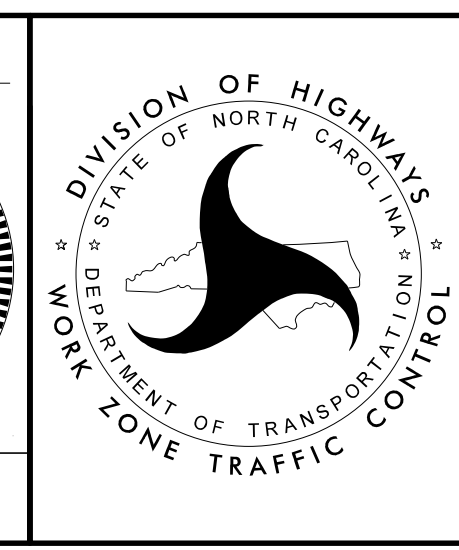

APPROVED: 
 DATE: 4/7/2022

**DOCUMENT NOT CONSIDERED FINAL
 UNLESS ALL SIGNATURES COMPLETED**

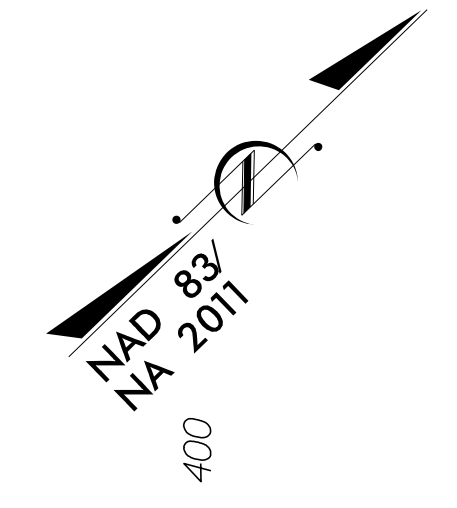

**PHASE I
 PLAN SHEET**



MATCHLINE -L- STA. 389 + 00.00
SEE SHEET TMP-33

MATCHLINE -L- STA. 402 + 00.00
SEE SHEET TMP-35

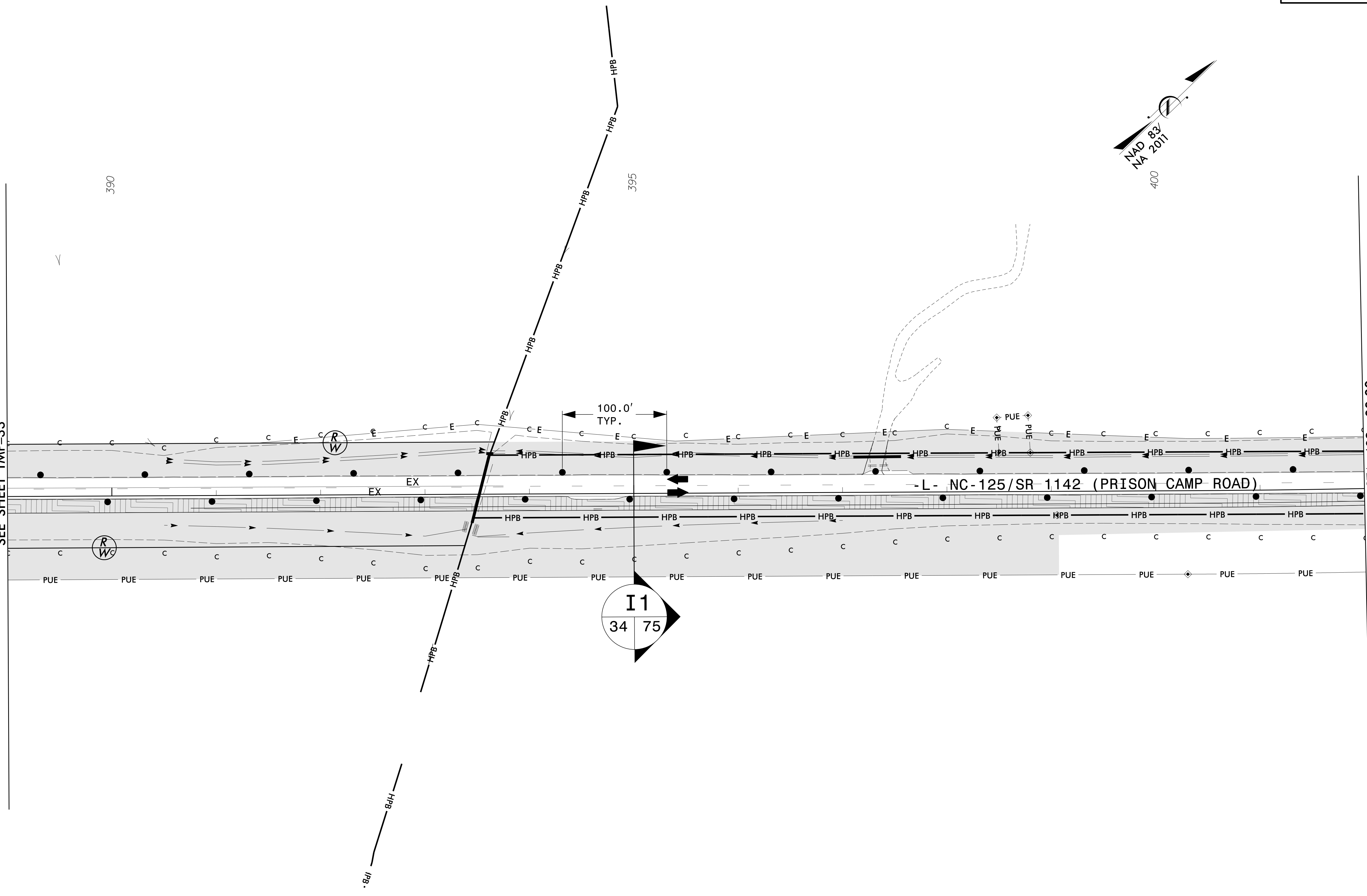

3/14/2022
 2/2/2022
 User: PH1.dgn
 R-4705-Find\Traffic\WZTC\TMP\Sheets\R-4705_TC_TMP_34_P1.dgn

ETHERILL ENGINEERING
 1223 Jones Franklin Rd.
 Raleigh, N.C. 27606
 License No. F-0377
 Bus: 919 851 8077
 Fax: 919 851 8107

TRANSPORTATION PLANNING/DESIGN - BRIDGE/STRUCTURE DESIGN
 CIVIL/SITE DESIGN - GIS/GPS - CONSTRUCTION OBSERVATION

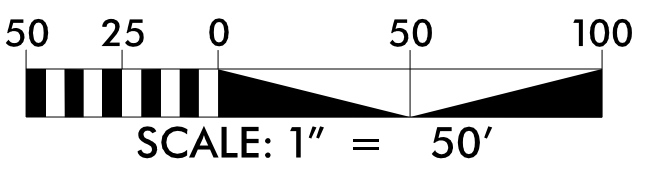

APPROVED: *E. H. May*
 DATE: 4/7/2022

PROFESSIONAL SEAL
 047751
 SOB A. MAY
 ENGINEER

**DOCUMENT NOT CONSIDERED FINAL
 UNLESS ALL SIGNATURES COMPLETED**

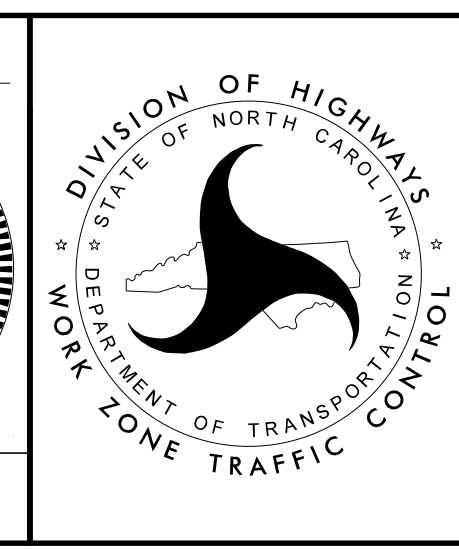

**PHASE I
 PLAN SHEET**

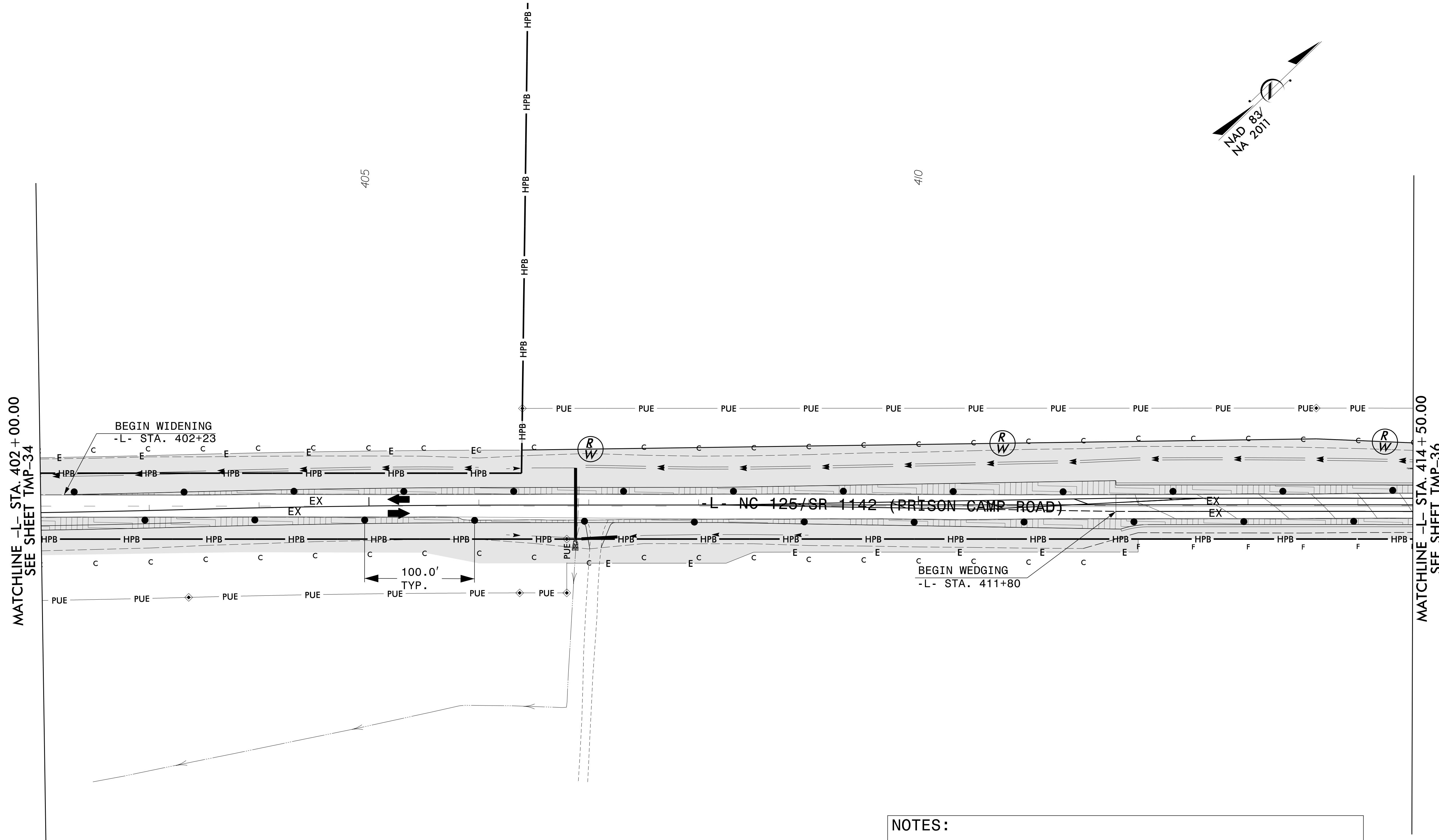

MATCHLINE -L- STA. 402 + 00.00
SEE SHEET TMP-34

MATCHLINE -L- STA. 414 + 50.00
SEE SHEET TMP-36

NOTES:

- CONTRACTOR SHALL INVENTORY EXISTING PAVEMENT MARKINGS AND REPLACE IN KIND UTILIZING TEMPORARY PAINT BETWEEN LIFTS OF PAVEMENT WITHIN WEDGING LIMITS.

3/14/2022
C:\2022\175.01-R-4705-Final-Traffic\WZTC\TMP\Sheets\R-4705-TC-TMP-35 PH1.dgn
User: rath04

ETHERILL ENGINEERING
 1223 Jones Franklin Rd.
 Raleigh, N.C. 27606
 License No. F-0377
 Bus: 919 851 8077
 Fax: 919 851 8107

TRANSPORTATION PLANNING/DESIGN - BRIDGE/STRUCTURE DESIGN
 CIVIL/SITE DESIGN - GIS/GPS - CONSTRUCTION OBSERVATION

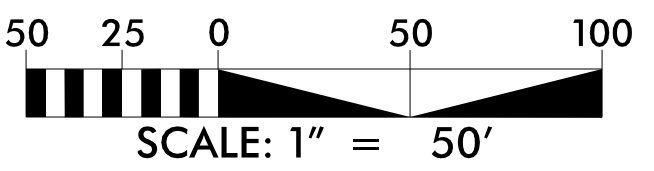

APPROVED: *Bob A. May*
DocuSigned by:
Bob A. May
5120642422492

DATE: 4/7/2022

**DOCUMENT NOT CONSIDERED FINAL
UNLESS ALL SIGNATURES COMPLETED**

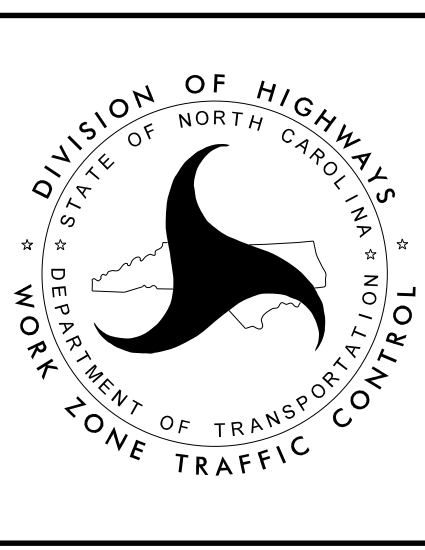

**PHASE I
PLAN SHEET**

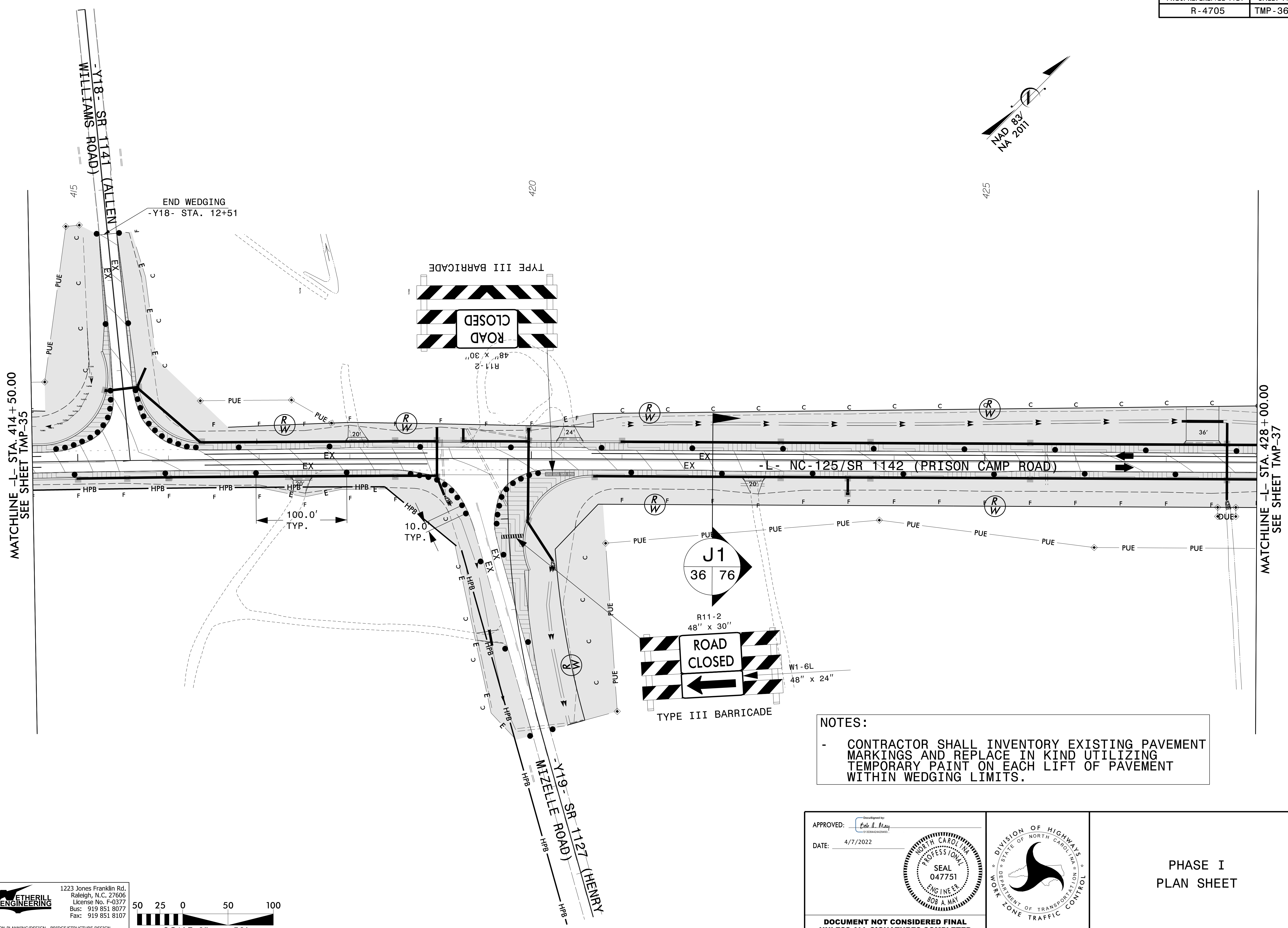
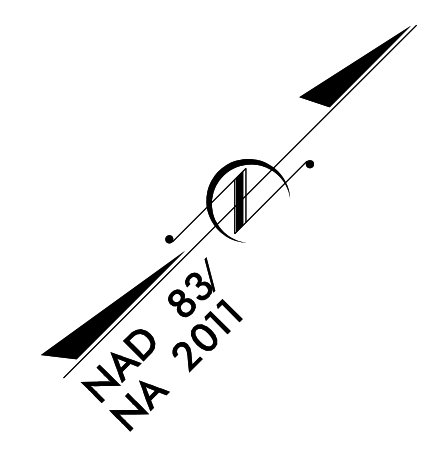

MATCHLINE -L- STA. 414+50.00
SEE SHEET TMP-35

MATCHLINE -L- STA. 428+00.00
SEE SHEET TMP-37

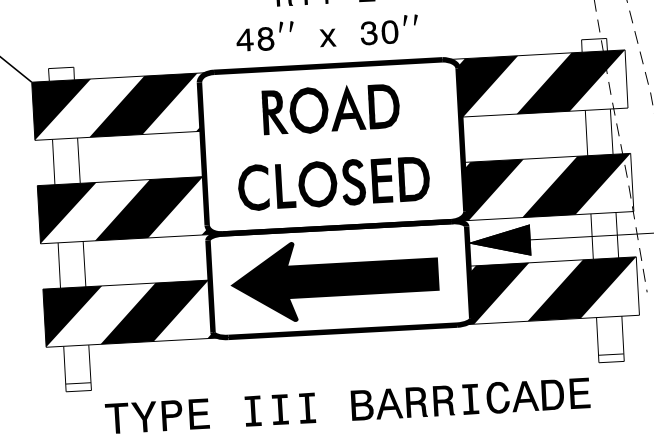
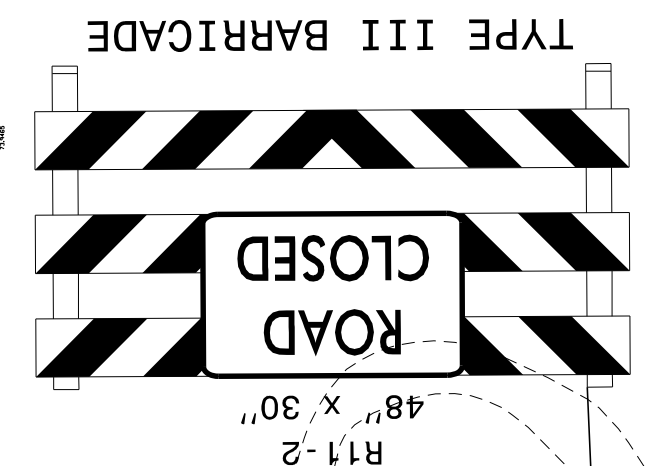

NOTES:
- CONTRACTOR SHALL INVENTORY EXISTING PAVEMENT MARKINGS AND REPLACE IN KIND UTILIZING TEMPORARY PAINT ON EACH LIFT OF PAVEMENT WITHIN WEDGING LIMITS.

3/14/2022
C:\2021\7175.01_R-4705-Final\Traffic\WZTC\TMP\Sheets\R-4705_TC_TMP_36_Phl.dgn
User: jh404/es

ETHERILL ENGINEERING
1223 Jones Franklin Rd.
Raleigh, N.C. 27606
License No. F-0377
Bus: 919 851 8077
Fax: 919 851 8107

TRANSPORTATION PLANNING/DESIGN - BRIDGE/STRUCTURE DESIGN
CIVIL/SITE DESIGN - GIS/GPS - CONSTRUCTION OBSERVATION

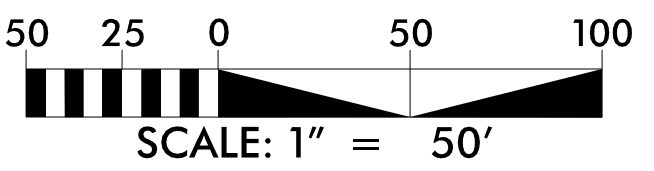

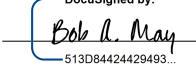
APPROVED: 
DATE: 4/7/2022

PROFESSIONAL SEAL
NORTH CAROLINA
047751
ENGINEER
BOB A. MAY

**DOCUMENT NOT CONSIDERED FINAL
UNLESS ALL SIGNATURES COMPLETED**

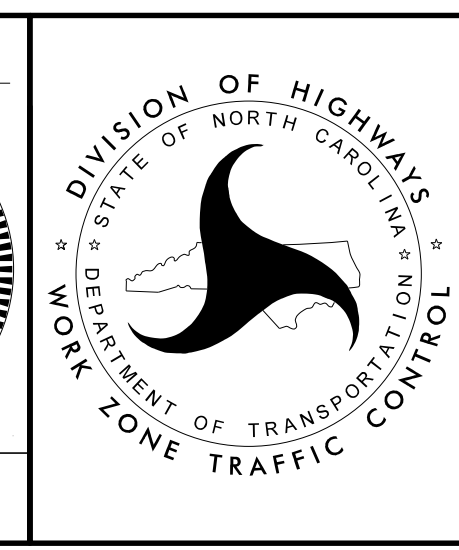

**PHASE I
PLAN SHEET**

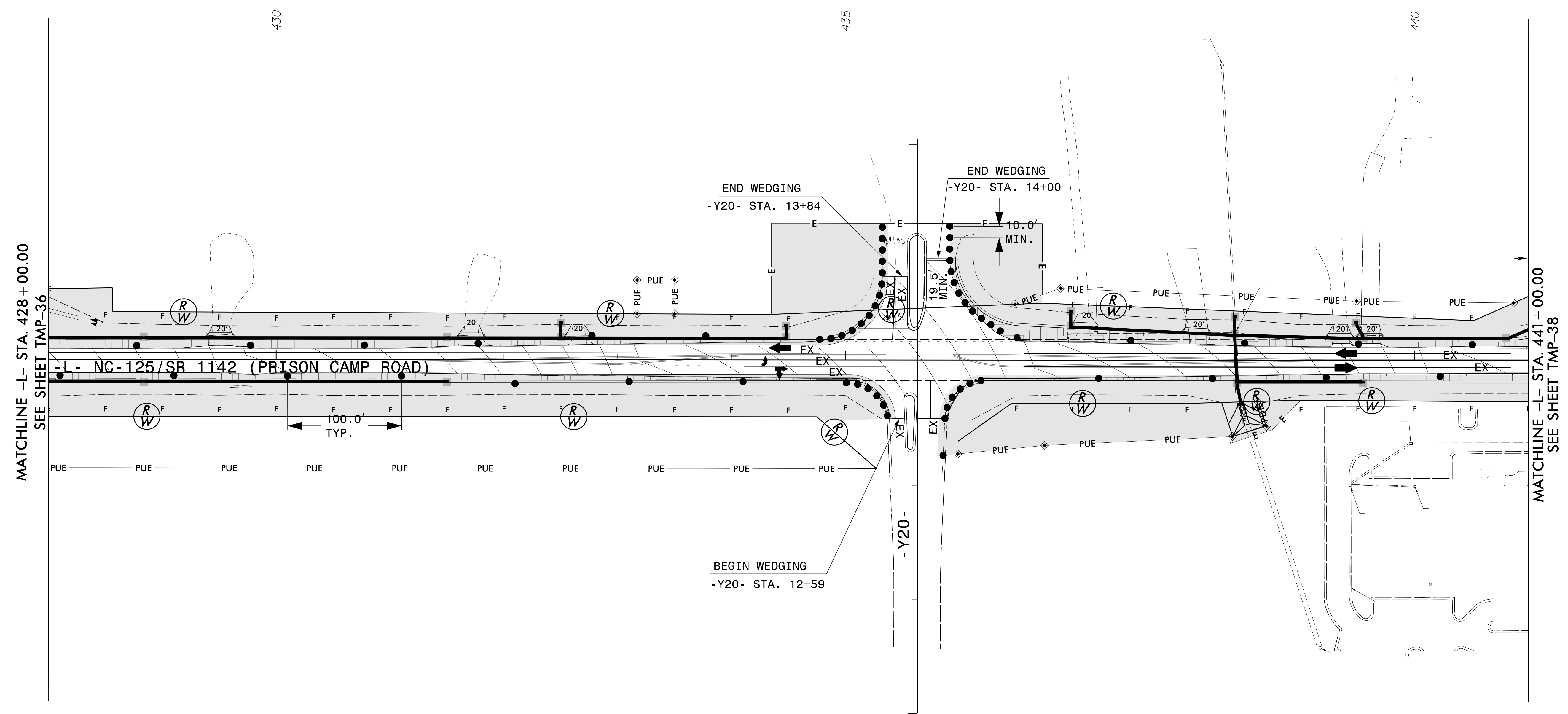
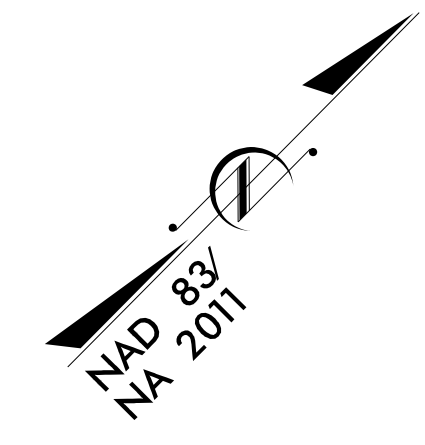

NOTES:

- CONTRACTOR SHALL INVENTORY EXISTING PAVEMENT MARKINGS AND REPLACE IN KIND UTILIZING TEMPORARY PAINT ON EACH LIFT OF PAVEMENT WITHIN WEDGING LIMITS.

APPROVED: *Bob A. May*
 DATE: 4/7/2022

**DOCUMENT NOT CONSIDERED FINAL
UNLESS ALL SIGNATURES COMPLETED**

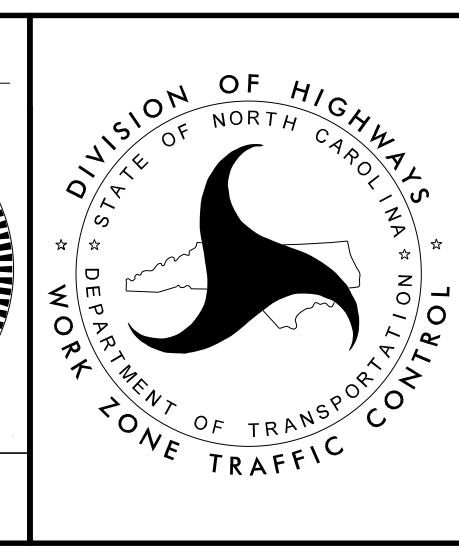

**PHASE I
PLAN SHEET**

3/14/2022
 C:\2022\175.01-R-4705-Final\Traffic\WZTC\TMP\Sheets\R-4705-TC_TMP_37_P1.dgn
 User: jh1414

1223 Jones Franklin Rd.
 Raleigh, N.C. 27606
 License No. F-0377
 Bus: 919 851 8077
 Fax: 919 851 8107

TRANSPORTATION PLANNING/DESIGN - BRIDGE/STRUCTURE DESIGN
 CIVIL/SITE DESIGN - GIS/GPS - CONSTRUCTION OBSERVATION

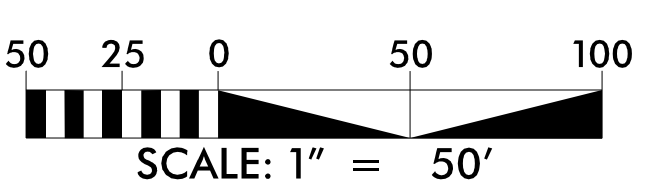

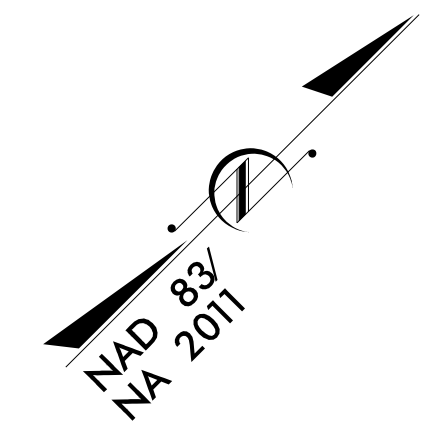
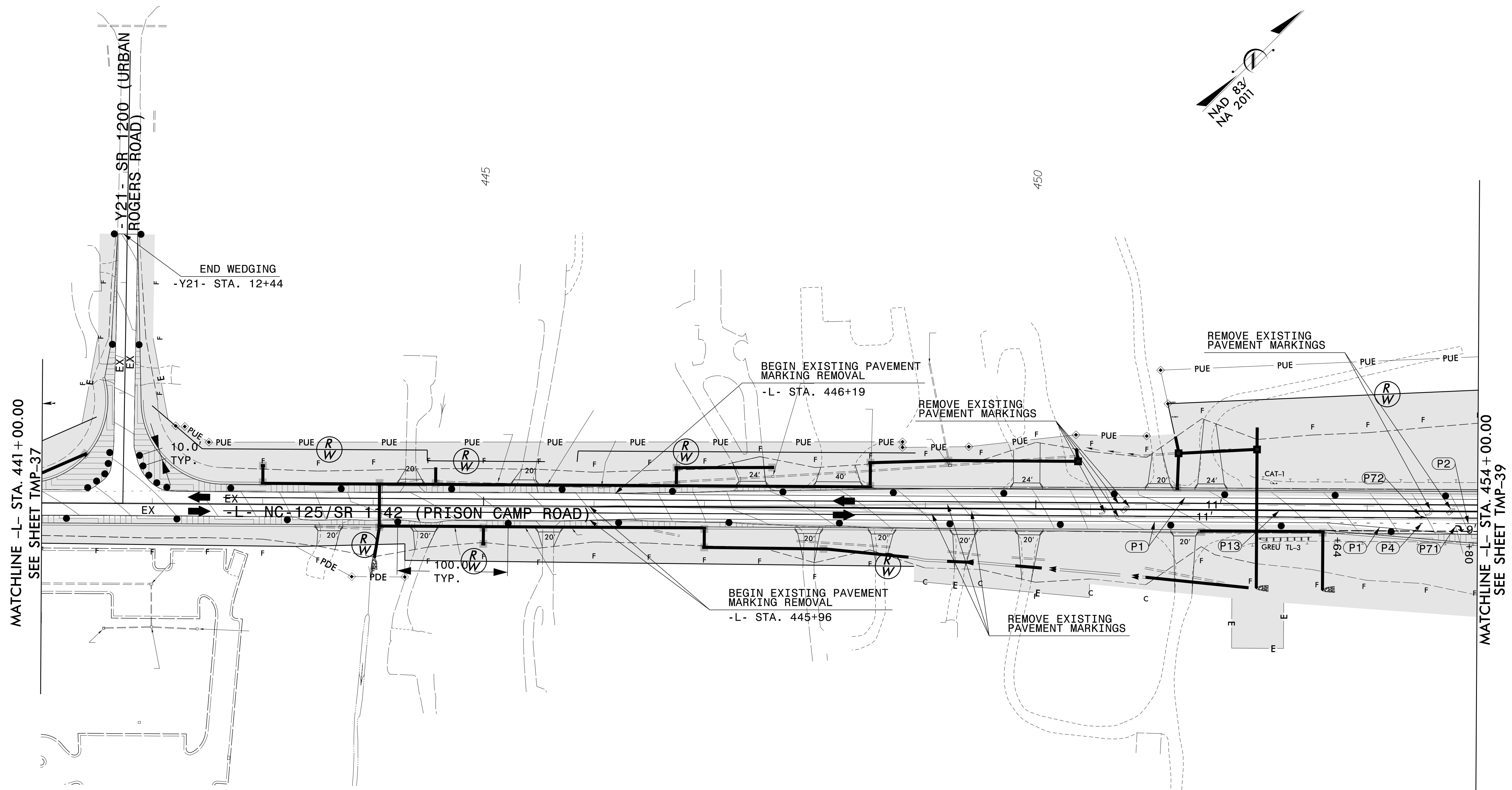

MATCHLINE -L- STA. 441+00.00
SEE SHEET TMP-37

MATCHLINE -L- STA. 454+00.00
SEE SHEET TMP-39

NOTES:

- CONTRACTOR SHALL INVENTORY EXISTING PAVEMENT MARKINGS AND REPLACE IN KIND UTILIZING TEMPORARY PAINT ON EACH LIFT OF PAVEMENT WITHIN WEDGING LIMITS.

ETHERILL ENGINEERING
 1223 Jones Franklin Rd.
 Raleigh, N.C. 27606
 License No. F-0377
 Bus: 919 851 8077
 Fax: 919 851 8107

TRANSPORTATION PLANNING/DESIGN - BRIDGE/STRUCTURE DESIGN
 CIVIL/SITE DESIGN - GIS/GPS - CONSTRUCTION OBSERVATION

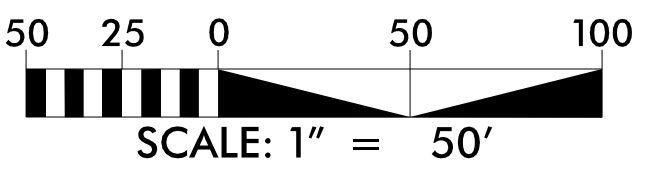

APPROVED: *Bob A. May*
DocuSigned by:
Bob A. May
51306424426491

DATE: 4/7/2022

PROFESSIONAL SEAL
 NORTH CAROLINA
 047751
 ENGINEER
 BOB A. MAY

**DOCUMENT NOT CONSIDERED FINAL
 UNLESS ALL SIGNATURES COMPLETED**

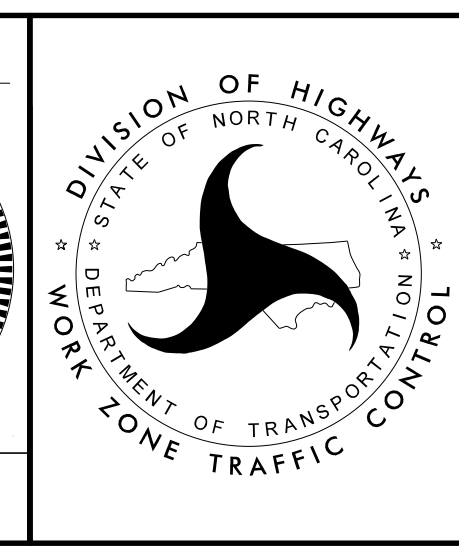

**PHASE I
 PLAN SHEET**

3/14/2022
 3/20/2022
 User: jh101
 R-4705-Final-Traffic-TMP-Sheets\R-4705-TC-TMP-38 PH1.dgn

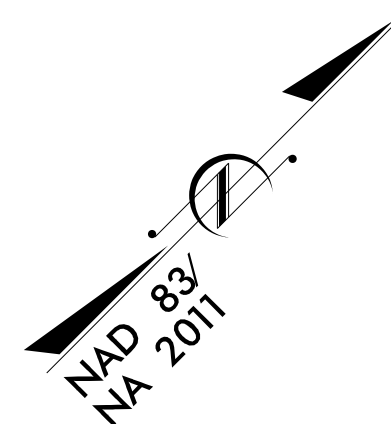
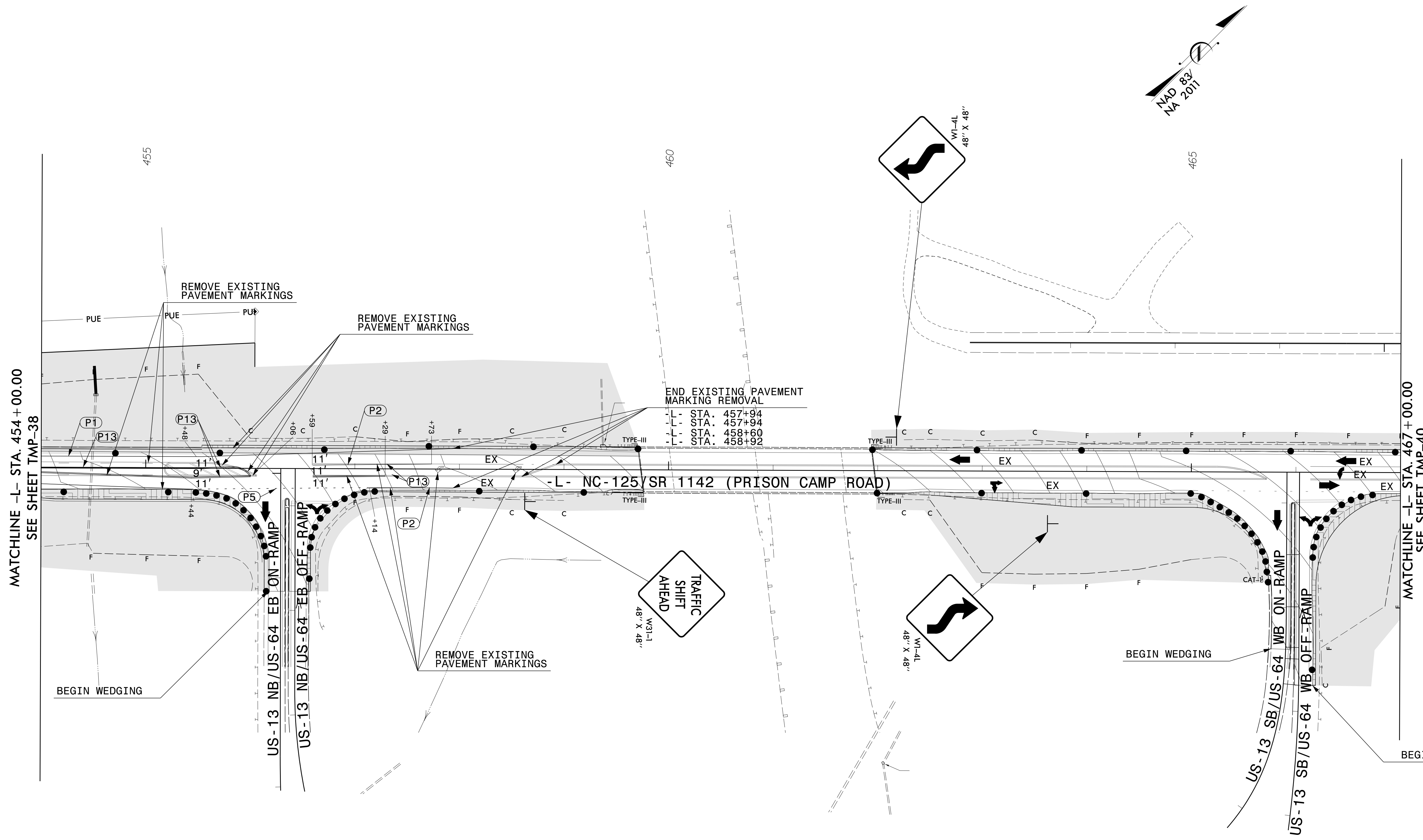

MATCHLINE -L- STA. 454+00.00
SEE SHEET TMP-38

MATCHLINE -L- STA. 467+00.00
SEE SHEET TMP-40

END EXISTING PAVEMENT MARKING REMOVAL
 -L- STA. 457+94
 -L- STA. 457+94
 -L- STA. 458+60
 -L- STA. 458+92

NOTES:

- CONTRACTOR SHALL INVENTORY EXISTING PAVEMENT MARKINGS AND REPLACE IN KIND UTILIZING TEMPORARY PAINT ON EACH LIFT OF PAVEMENT WITHIN WEDGING LIMITS.

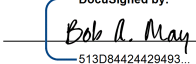
APPROVED: 
 DATE: 4/7/2022



**DOCUMENT NOT CONSIDERED FINAL
UNLESS ALL SIGNATURES COMPLETED**

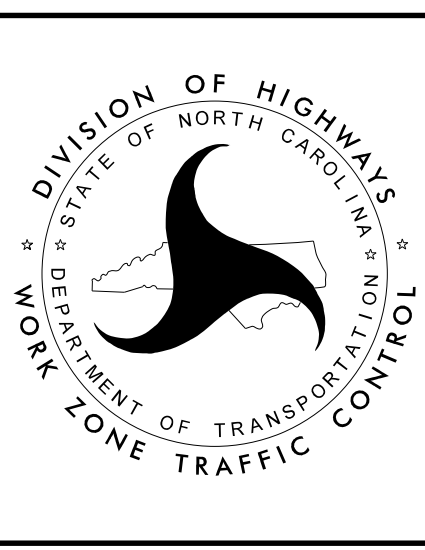

**PHASE I
PLAN SHEET**

3/14/2022
 C:\2021\7175.01-R-4705-Final\Traffic\WZTC\TMP\Sheets\R-4705-TC-TMP-39 PH1.dgn
 User: rathayes

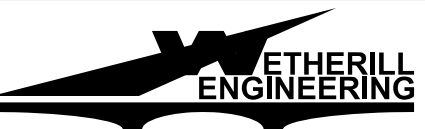
 **ETHERILL ENGINEERING**
 1223 Jones Franklin Rd.
 Raleigh, N.C. 27606
 License No. F-0377
 Bus: 919 851 8077
 Fax: 919 851 8107

TRANSPORTATION PLANNING/DESIGN - BRIDGE/STRUCTURE DESIGN
 CIVIL/SITE DESIGN - GIS/GPS - CONSTRUCTION OBSERVATION

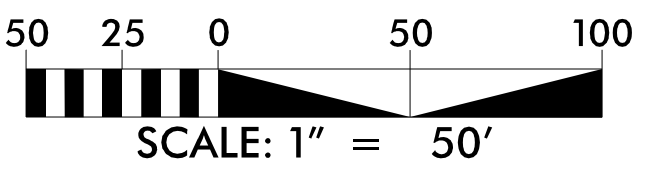

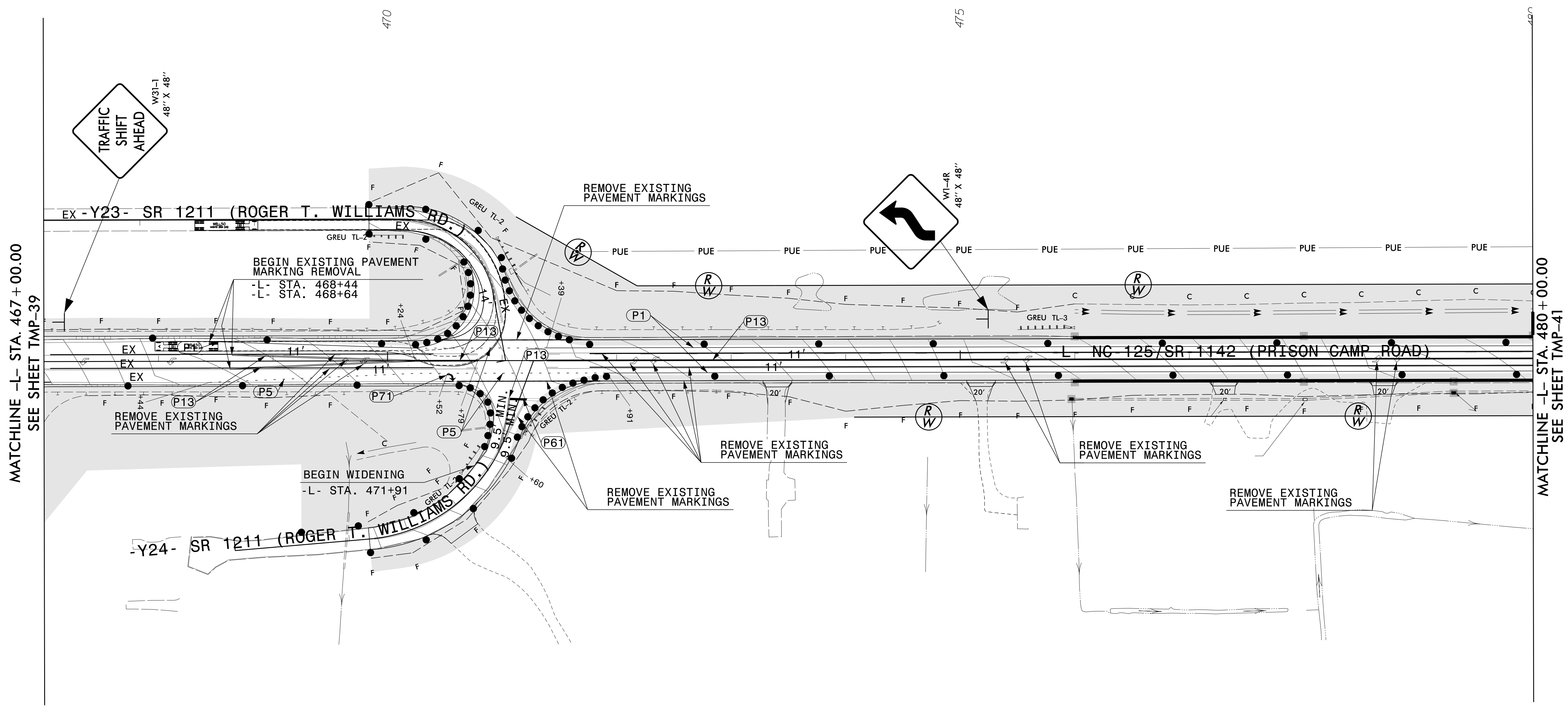
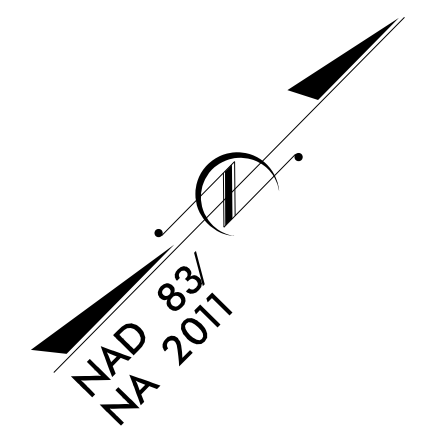



MATCHLINE -L- STA. 467+00.00
SEE SHEET TMP-39

MATCHLINE -L- STA. 480+00.00
SEE SHEET TMP-41

NOTES:

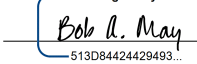
- CONTRACTOR SHALL INVENTORY EXISTING PAVEMENT MARKINGS AND REPLACE IN KIND UTILIZING TEMPORARY PAINT ON EACH LIFT OF PAVEMENT WITHIN WEDGING LIMITS.

APPROVED: 
 DATE: 4/7/2022



**DOCUMENT NOT CONSIDERED FINAL
UNLESS ALL SIGNATURES COMPLETED**

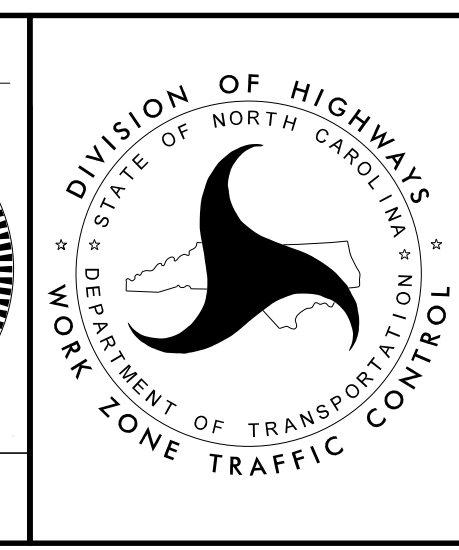

**PHASE I
PLAN SHEET**

3/14/2022
 C:\2021\175.01-R-4705-Final\Traffic\WZTC\TMP\Sheets\R-4705_TC_TMP_40_Phi.dgn
 User: jhughes



1223 Jones Franklin Rd.
 Raleigh, N.C. 27606
 License No. F-0377
 Bus: 919 851 8077
 Fax: 919 851 8107

TRANSPORTATION PLANNING/DESIGN - BRIDGE/STRUCTURE DESIGN
 CIVIL/SITE DESIGN - GIS/GPS - CONSTRUCTION OBSERVATION

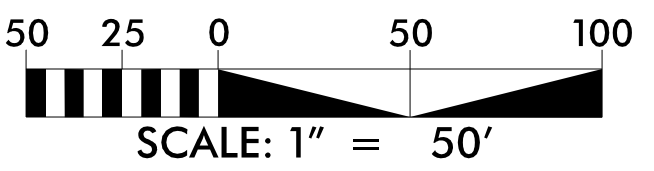

MATCHLINE -L- STA. 480+00.00
SEE SHEET TMP-40

MATCHLINE -L- STA. 493+00.00
SEE SHEET TMP-42

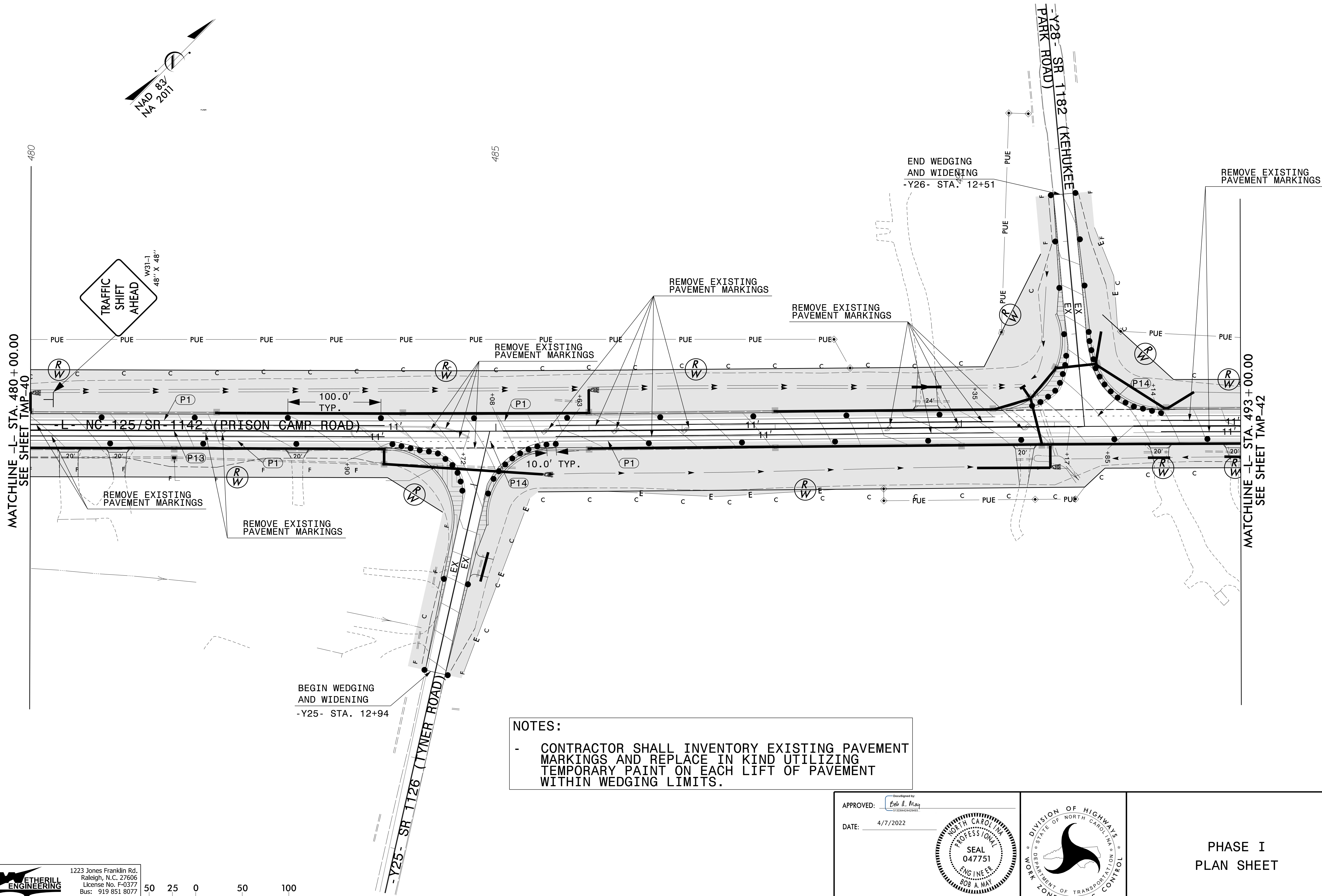

TRAFFIC SHIFT AHEAD
W31-1
48' X 48'

NOTES:
- CONTRACTOR SHALL INVENTORY EXISTING PAVEMENT MARKINGS AND REPLACE IN KIND UTILIZING TEMPORARY PAINT ON EACH LIFT OF PAVEMENT WITHIN WEDGING LIMITS.

BEGIN WEDGING AND WIDENING
-Y25- STA. 12+94

END WEDGING AND WIDENING
-Y26- STA. 12+51

REMOVE EXISTING PAVEMENT MARKINGS

ETHERILL ENGINEERING
1223 Jones Franklin Rd.
Raleigh, N.C. 27606
License No. F-0377
Bus: 919 851 8077
Fax: 919 851 8107

TRANSPORTATION PLANNING/DESIGN - BRIDGE/STRUCTURE DESIGN
CIVIL/SITE DESIGN - GIS/GPS - CONSTRUCTION OBSERVATION

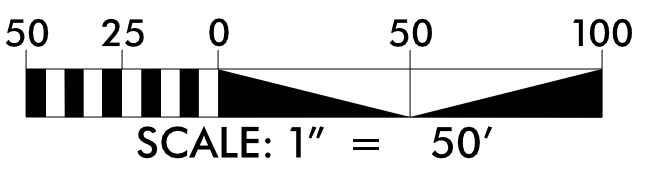

APPROVED: *Bob A. May*
DATE: 4/7/2022

PROFESSIONAL SEAL
047751
ENGINEER
BOB A. MAY

DOCUMENT NOT CONSIDERED FINAL UNLESS ALL SIGNATURES COMPLETED

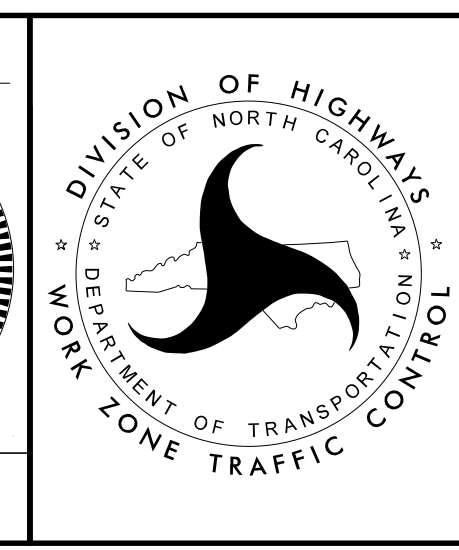

PHASE I
PLAN SHEET

3/14/2022
C:\2021\7175.01-R-4705-Final\Traffic\WZTC\TMP\Sheets\R-4705_TC_TMP_41.Pht.dgn
User: jphayes

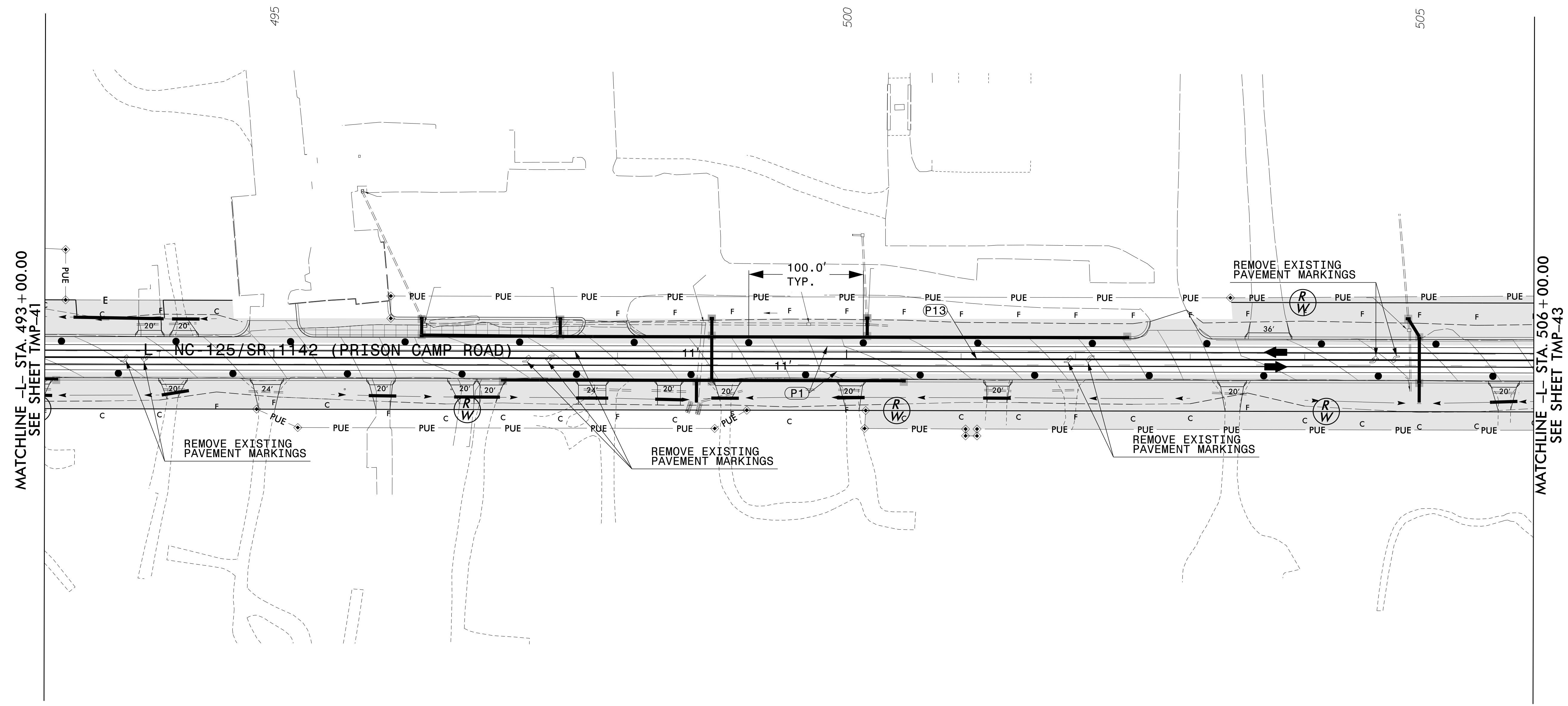
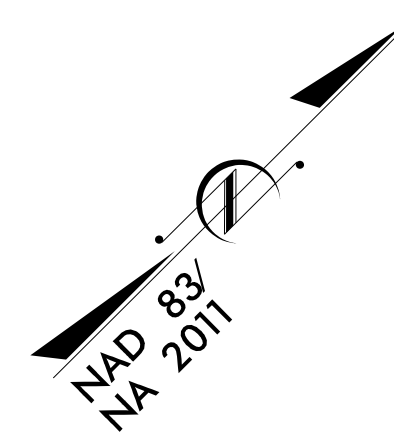

MATCHLINE -L- STA. 493 + 00.00
SEE SHEET TMP-41

MATCHLINE -L- STA. 506 + 00.00
SEE SHEET TMP-43

3/14/2022
C:\2021\7175.01_R-4705-Final\Traffic\WZTC\TMP\Sheets\R-4705_TC_TMP_42_P1.dgn
User: rathayes

ETHERILL ENGINEERING
1223 Jones Franklin Rd.
Raleigh, N.C. 27606
License No. F-0377
Bus: 919 851 8077
Fax: 919 851 8107

TRANSPORTATION PLANNING/DESIGN - BRIDGE/STRUCTURE DESIGN
CIVIL/SITE DESIGN - GIS/GPS - CONSTRUCTION OBSERVATION

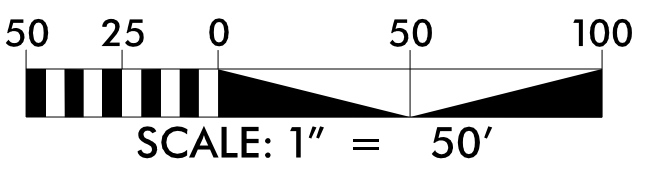

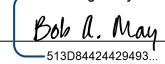
APPROVED: 
DATE: 4/7/2022

PROFESSIONAL SEAL
NORTH CAROLINA
ENGINEER
047751
BOB A. MAY

**DOCUMENT NOT CONSIDERED FINAL
UNLESS ALL SIGNATURES COMPLETED**

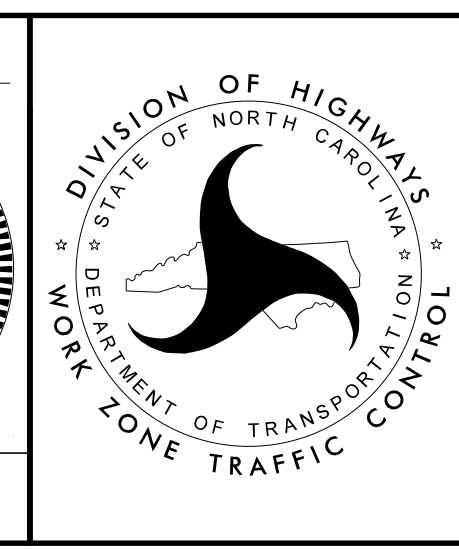

**PHASE I
PLAN SHEET**

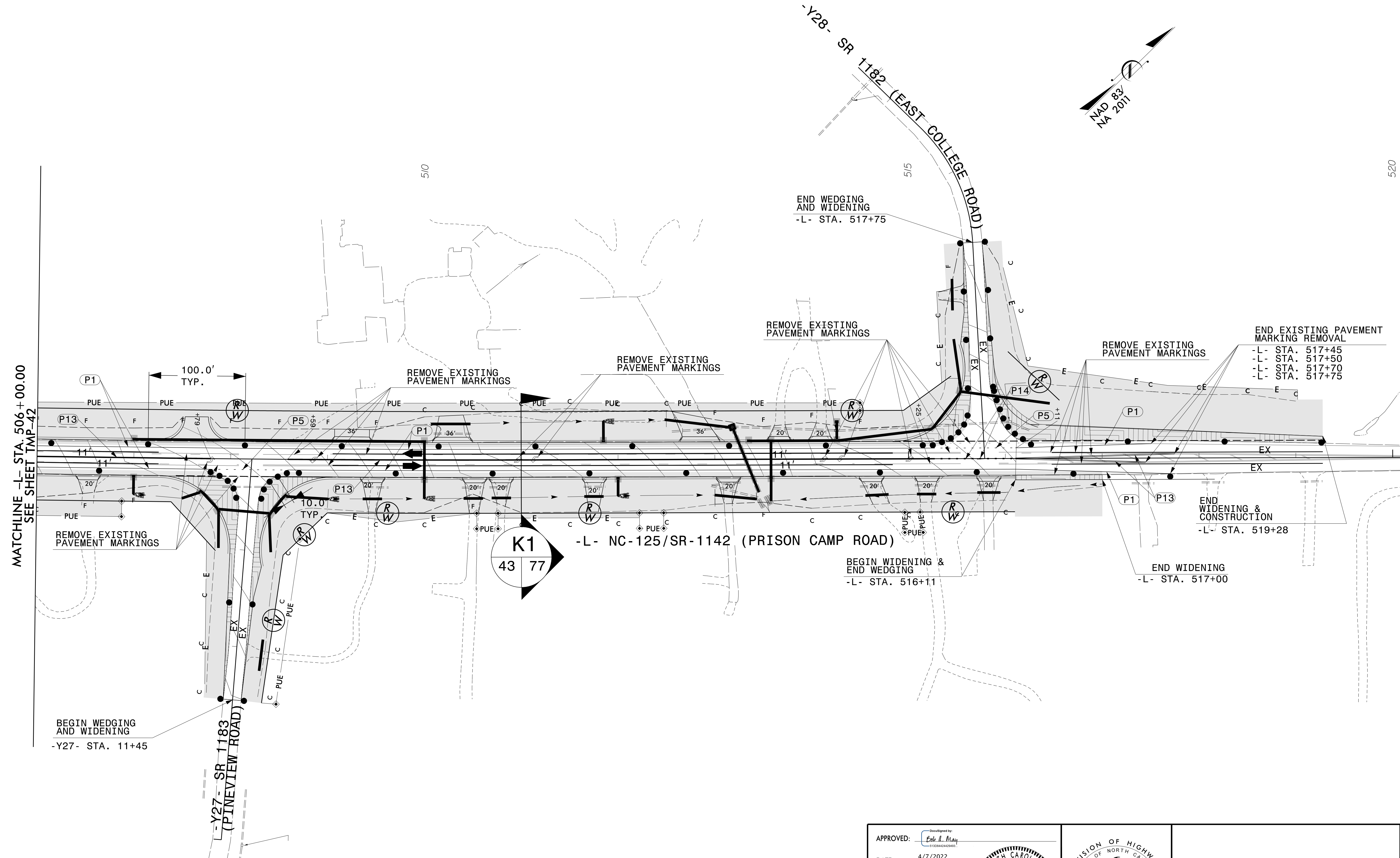

MATCHLINE -L- STA. 506+00.00
SEE SHEET TMP-42

BEGIN WEDGING AND WIDENING
-L- STA. 11+45

END WEDGING AND WIDENING
-L- STA. 517+75

END EXISTING PAVEMENT MARKING REMOVAL
-L- STA. 517+45
-L- STA. 517+50
-L- STA. 517+70
-L- STA. 517+75

END WIDENING & CONSTRUCTION
-L- STA. 519+28

END WIDENING
-L- STA. 517+00

-L- NC-125/SR-1142 (PRISON CAMP ROAD)

BEGIN WIDENING & END WEDGING
-L- STA. 516+11

NOTES:
- CONTRACTOR SHALL INVENTORY EXISTING PAVEMENT MARKINGS AND REPLACE IN KIND UTILIZING TEMPORARY PAINT ON EACH LIFT OF PAVEMENT WITHIN WEDGING LIMITS.

APPROVED: *Bob A. May*
DATE: 4/7/2022

DOCUMENT NOT CONSIDERED FINAL
UNLESS ALL SIGNATURES COMPLETED

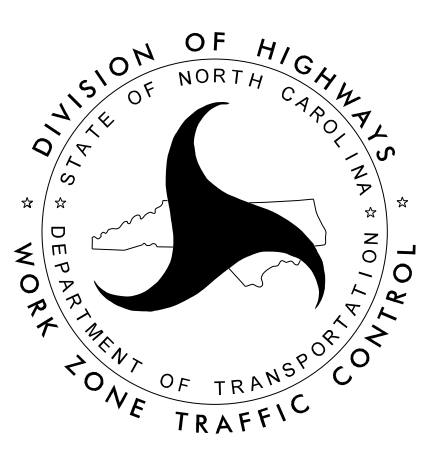

PHASE I
PLAN SHEET

3/14/2022 3:20:17 PM C:\Users\jfranklin\OneDrive\Documents\Projects\4705-TMP-43\4705-TMP-43.dgn

ETHERILL ENGINEERING
1223 Jones Franklin Rd.
Raleigh, N.C. 27606
License No. F-0377
Bus: 919 851 8077
Fax: 919 851 8107

TRANSPORTATION PLANNING/DESIGN - BRIDGE/STRUCTURE DESIGN
CIVIL/SITE DESIGN - GIS/GPS - CONSTRUCTION OBSERVATION

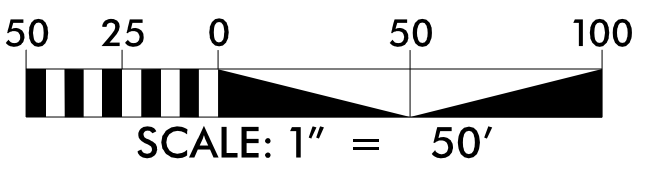

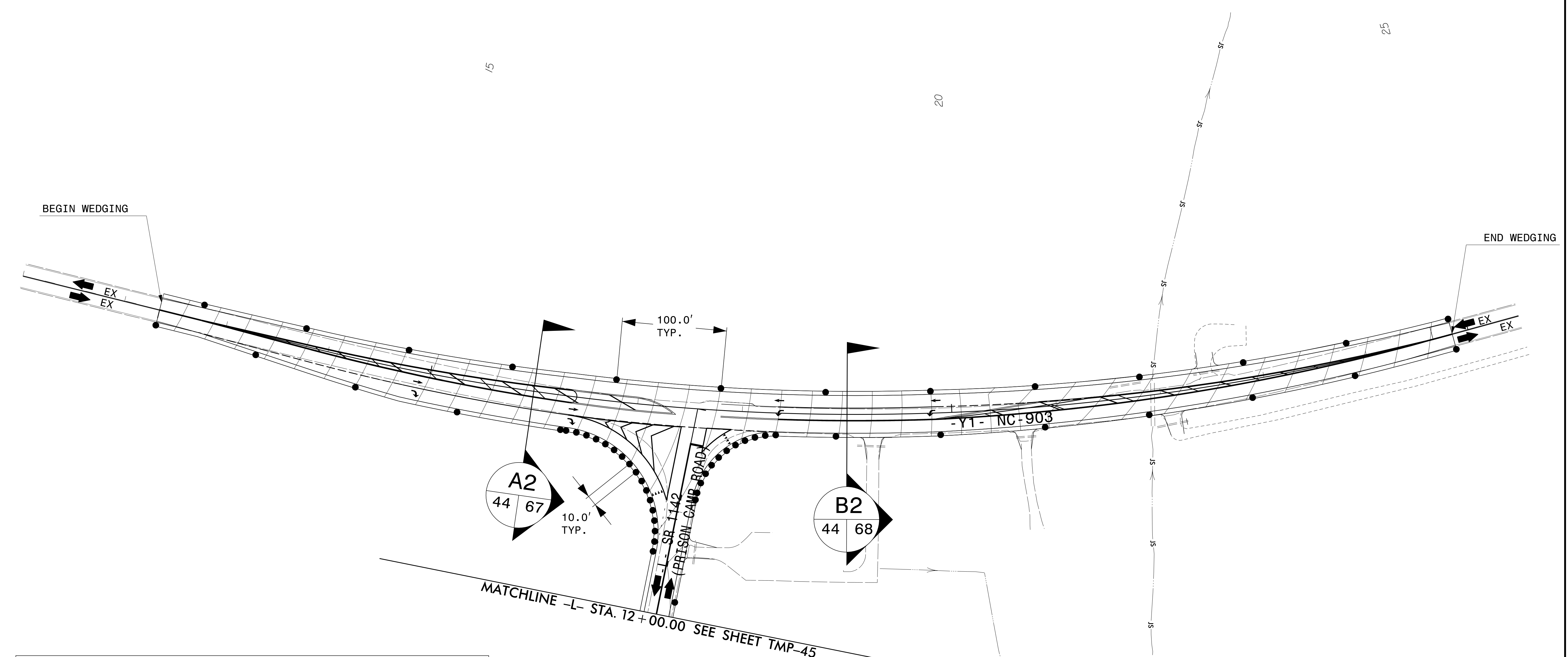
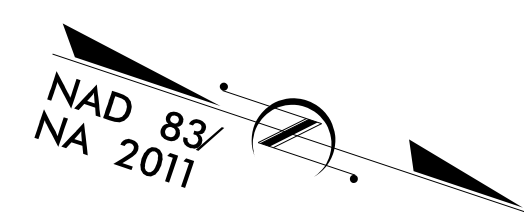

NOTES:

- CONTRACTOR SHALL INSTALL PAVEMENT MARKINGS PER THE FINAL PAVEMENT MARKING PLANS AND UTILIZE TEMPORARY PAINT.

4/19/2022
 P:\2022\7175.01_R-4705-Final\Traffic\WZTC\TMP\Sheets\R-4705_TC_TMP_44_Phil.dgn
 User: phil@etherill.com

ETHERILL ENGINEERING
 1223 Jones Franklin Rd.
 Raleigh, N.C. 27606
 License No. F-0377
 Bus: 919 851 8077
 Fax: 919 851 8107

TRANSPORTATION PLANNING/DESIGN - BRIDGE/STRUCTURE DESIGN
 CIVIL/SITE DESIGN - GIS/GPS - CONSTRUCTION OBSERVATION

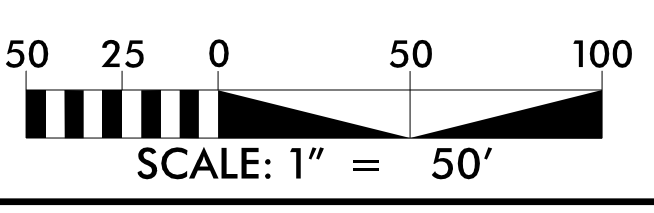

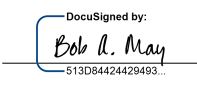
APPROVED: 
 DATE: 4/19/2022

PROFESSIONAL SEAL
 NORTH CAROLINA
 047751
 ENGINEER
 BOB A. MAY

**DOCUMENT NOT CONSIDERED FINAL
 UNLESS ALL SIGNATURES COMPLETED**

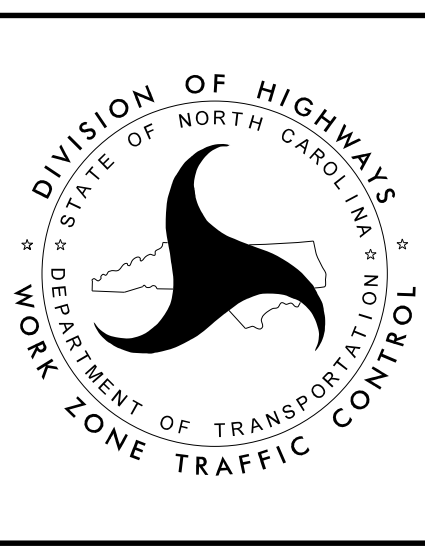

**PHASE II
 PLAN SHEET**

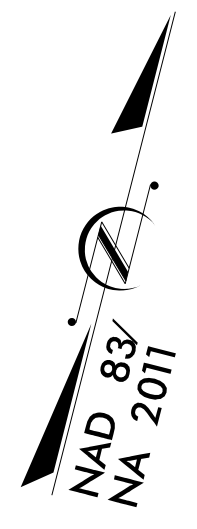

MATCHLINE -L- STA. 12 + 00.00
SEE SHEET TMP-44

MATCHLINE -L- STA. 25 + 00.00
SEE SHEET TMP-46

L- NC-125/SR 1142 (PRISON CAMP ROAD)

100.0'
TYP.

0509

4/19/2022
P:\2021\75.01-R-4705-Final\Traffic\WZTC\TMP\Sheets\R-4705_TC_TMP_45_Phil.dgn
User: phil@es

1223 Jones Franklin Rd.
Raleigh, N.C. 27606
License No. F-0377
Bus: 919 851 8077
Fax: 919 851 8107

TRANSPORTATION PLANNING/DESIGN - BRIDGE/STRUCTURE DESIGN
CIVIL/SITE DESIGN - GIS/GPS - CONSTRUCTION OBSERVATION

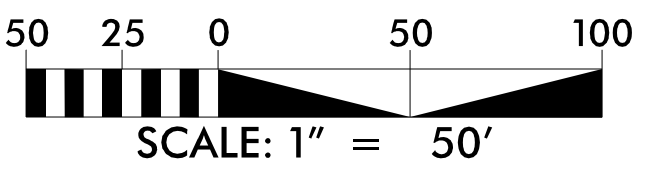

NOTES:

- CONTRACTOR SHALL INSTALL PAVEMENT MARKINGS PER THE FINAL PAVEMENT MARKING PLANS AND UTILIZE TEMPORARY PAINT.

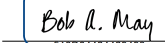
APPROVED: 
DATE: 4/19/2022

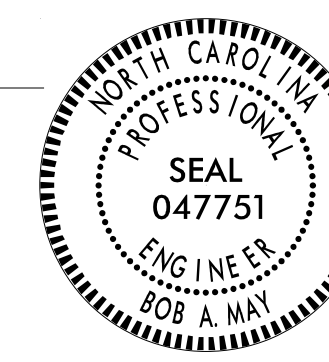

**DOCUMENT NOT CONSIDERED FINAL
UNLESS ALL SIGNATURES COMPLETED**

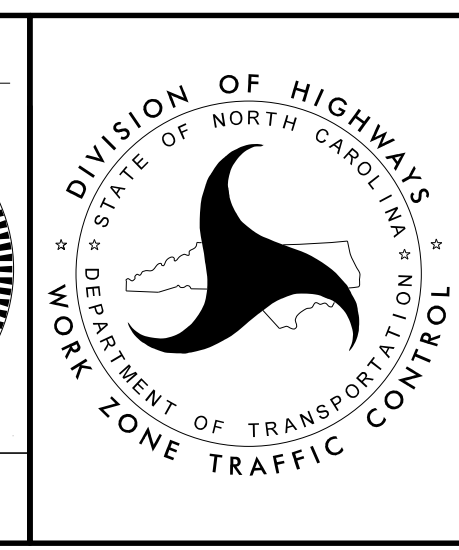

**PHASE II
PLAN SHEET**

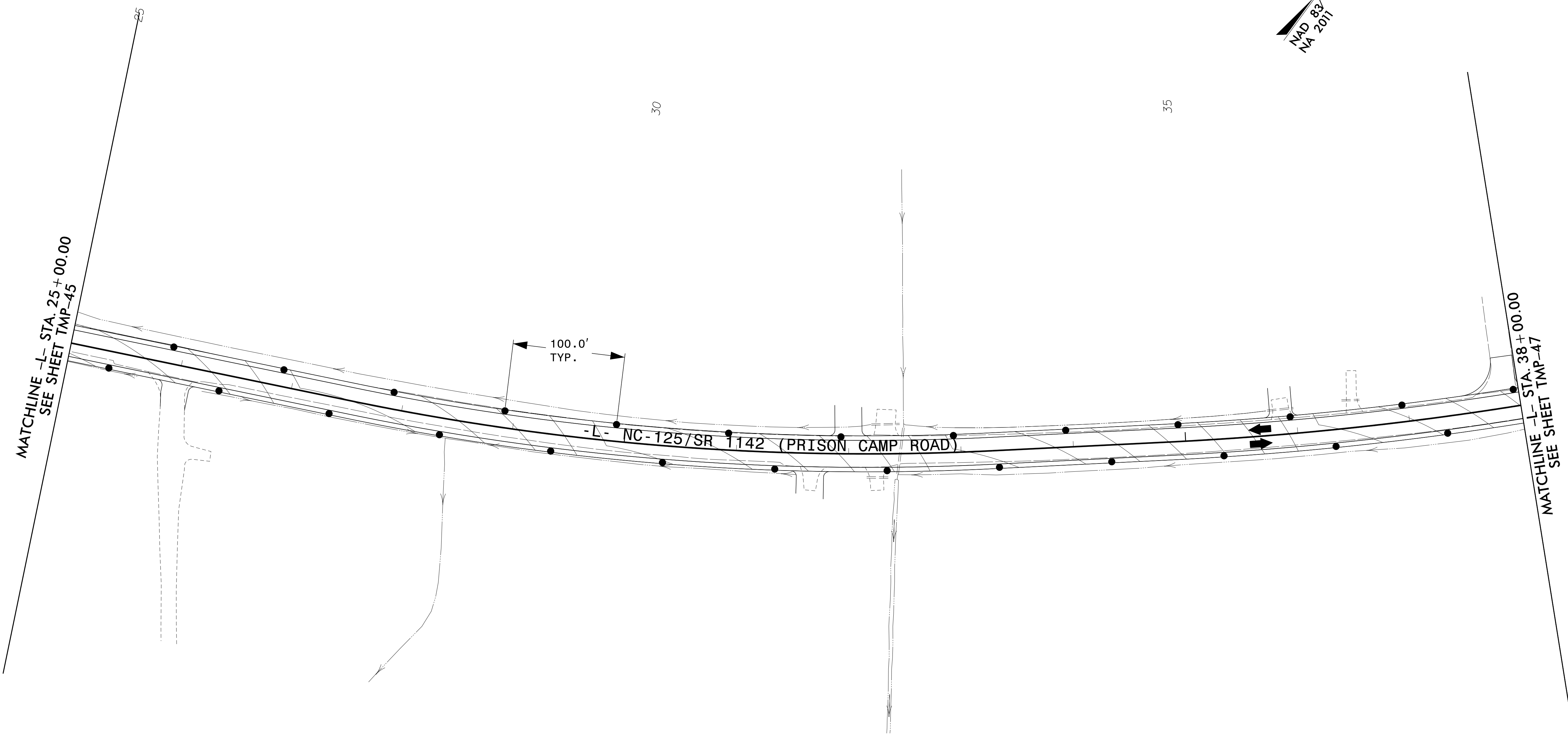
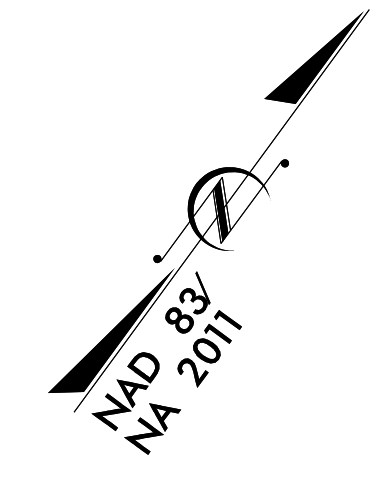

4/19/2022
 P:\2020\7175.01_R-4705-Final\Traffic\WZTC\TMP\Sheets\R-4705_TC_TMP_46_Phil.dgn
 User: phil

1223 Jones Franklin Rd.
 Raleigh, N.C. 27606
 License No. F-0377
 Bus: 919 851 8077
 Fax: 919 851 8107

TRANSPORTATION PLANNING/DESIGN - BRIDGE/STRUCTURE DESIGN
 CIVIL/SITE DESIGN - GIS/GPS - CONSTRUCTION OBSERVATION

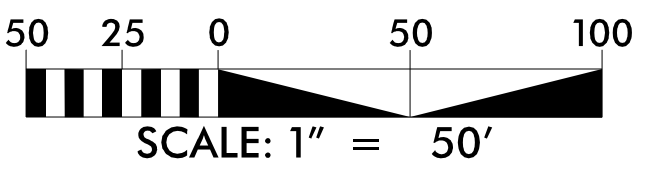

NOTES:

- CONTRACTOR SHALL INSTALL PAVEMENT MARKINGS PER THE FINAL PAVEMENT MARKING PLANS AND UTILIZE TEMPORARY PAINT.

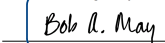
APPROVED: 
 DATE: 4/19/2022

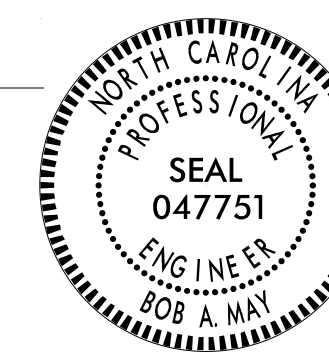

**DOCUMENT NOT CONSIDERED FINAL
 UNLESS ALL SIGNATURES COMPLETED**

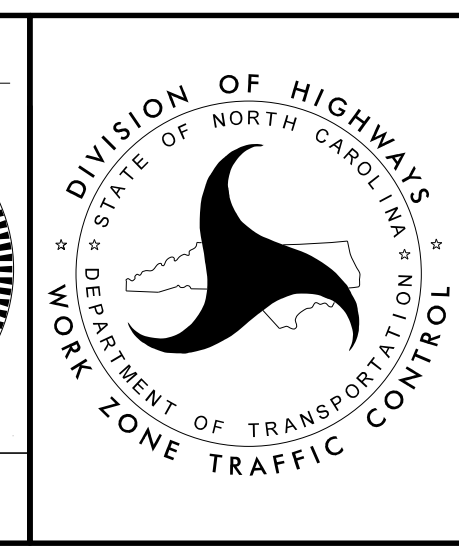

**PHASE II
 PLAN SHEET**

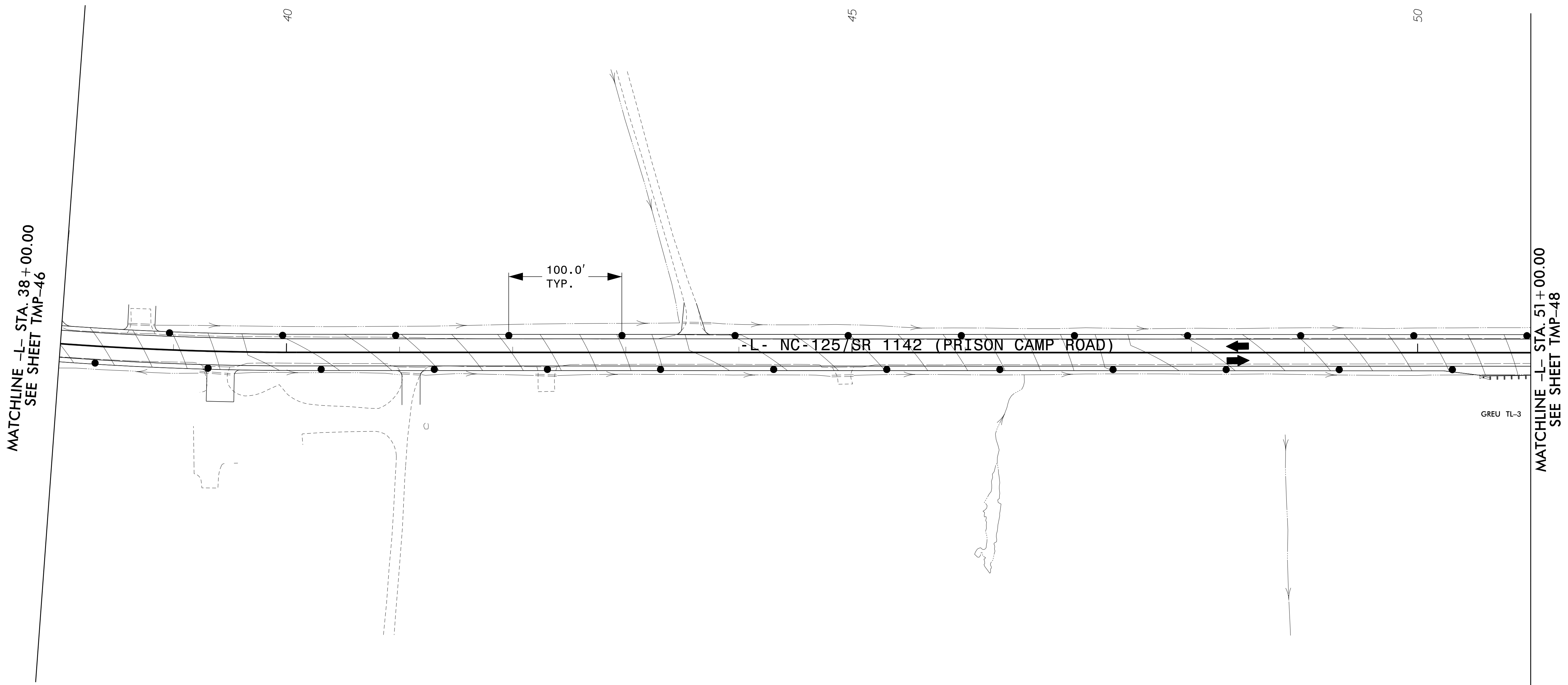

4/19/2022
 P:\2020\175.01_R-4705-Final\Traffic\WZTC\TMP\Sheets\R-4705_TC_TMP_47_Phil.dgn
 User: phil

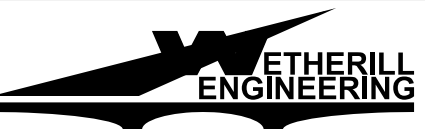

 1223 Jones Franklin Rd.
 Raleigh, N.C. 27606
 License No. F-0377
 Bus: 919 851 8077
 Fax: 919 851 8107

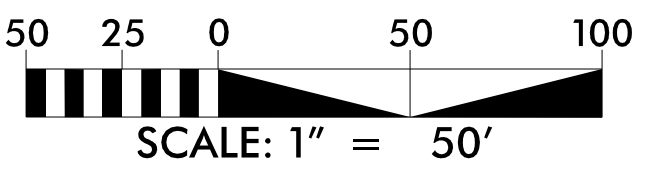
TRANSPORTATION PLANNING/DESIGN - BRIDGE/STRUCTURE DESIGN
 CIVIL/SITE DESIGN - GIS/GPS - CONSTRUCTION OBSERVATION

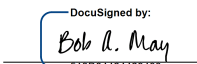

NOTES:

- CONTRACTOR SHALL INSTALL PAVEMENT MARKINGS PER THE FINAL PAVEMENT MARKING PLANS AND UTILIZE TEMPORARY PAINT.

APPROVED: 
 DATE: 4/19/2022



DOCUMENT NOT CONSIDERED FINAL UNLESS ALL SIGNATURES COMPLETED

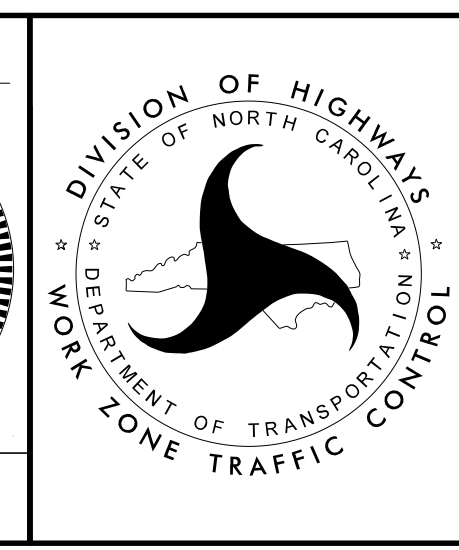

**PHASE II
 PLAN SHEET**

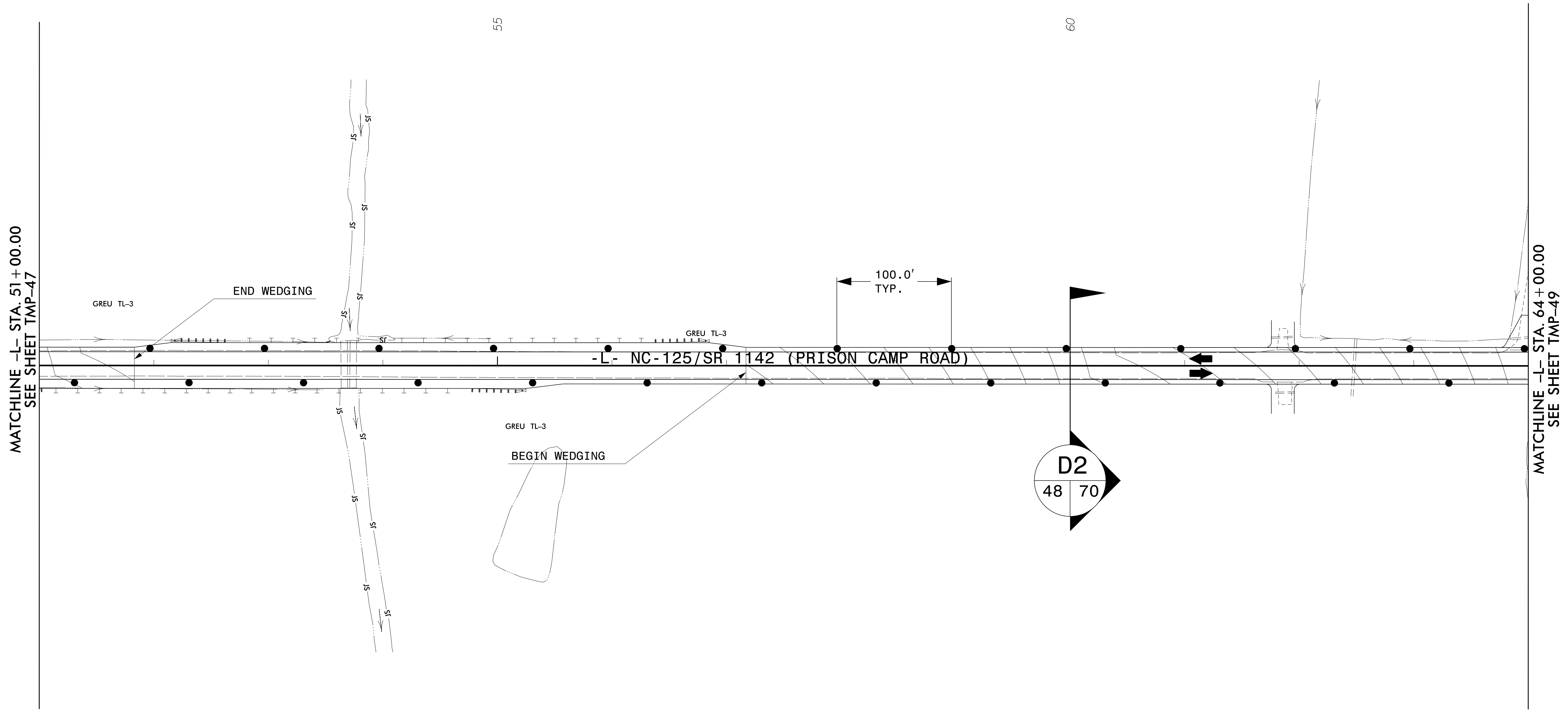
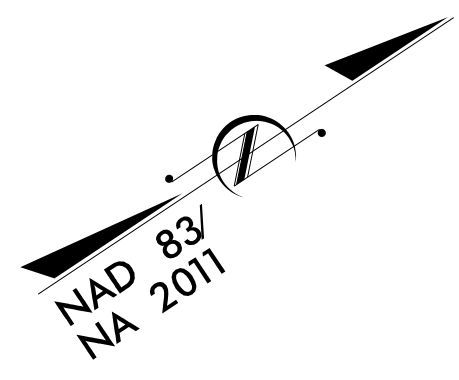

NOTES:

- CONTRACTOR SHALL INSTALL PAVEMENT MARKINGS PER THE FINAL PAVEMENT MARKING PLANS AND UTILIZE TEMPORARY PAINT.

ETHERILL ENGINEERING
 1223 Jones Franklin Rd.
 Raleigh, N.C. 27606
 License No. F-0377
 Bus: 919 851 8077
 Fax: 919 851 8107

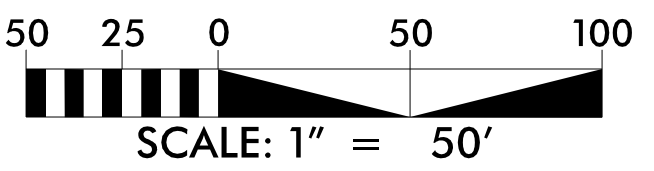

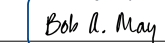
APPROVED: 
 DATE: 4/19/2022

PROFESSIONAL SEAL
 NORTH CAROLINA
 047751
 ENGINEER
 BOB A. MAY

**DOCUMENT NOT CONSIDERED FINAL
 UNLESS ALL SIGNATURES COMPLETED**

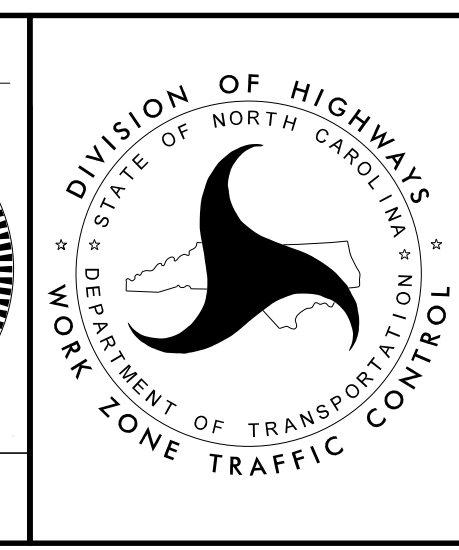

**PHASE II
 PLAN SHEET**

4/19/2022
 P:\2022\175.01_R-4705-Final\Traffic\WZTC\TMP\Sheets\R-4705_TC_TMP_48_Phil.dgn
 User: phil@etherill.com

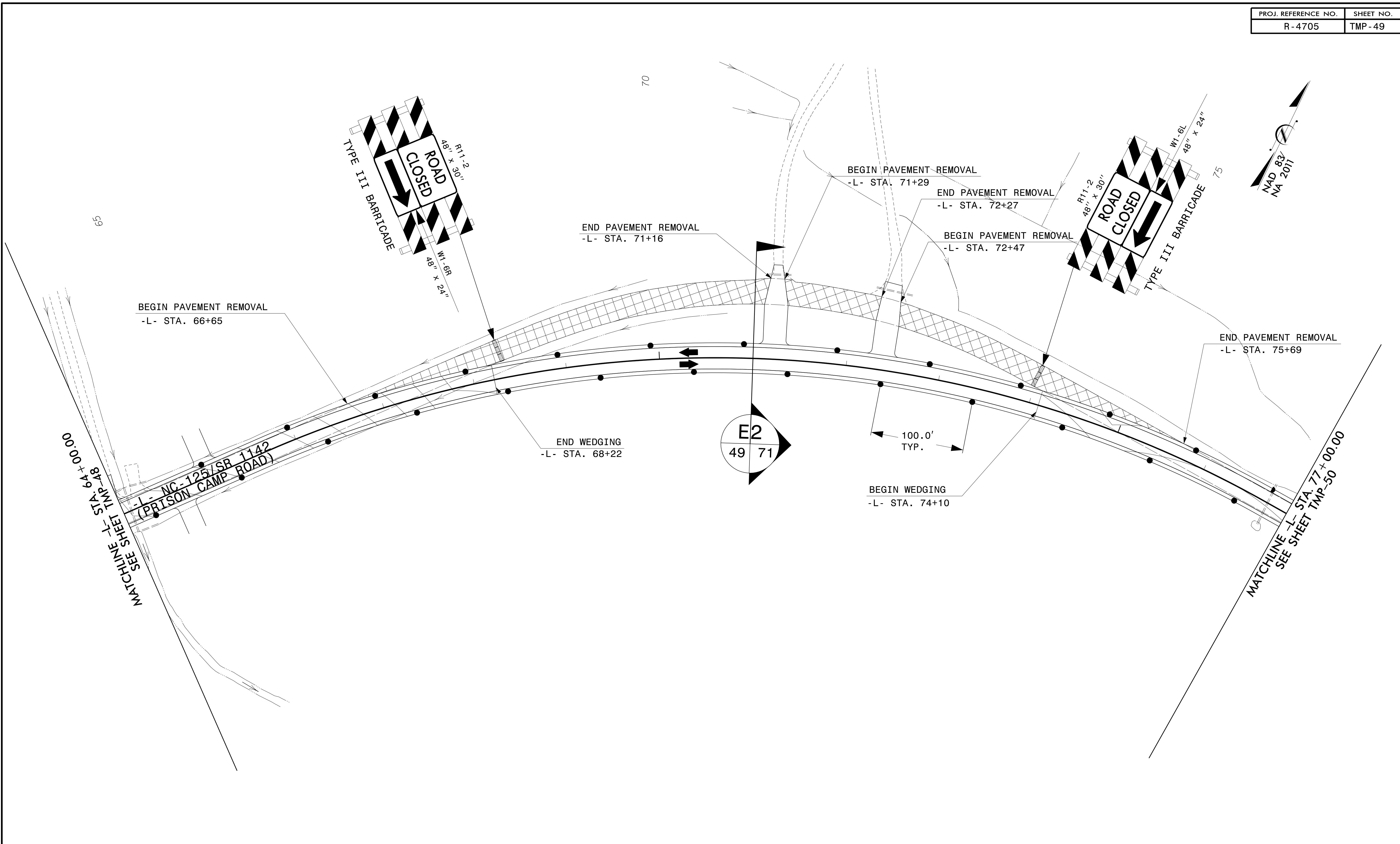

NOTES:

- CONTRACTOR SHALL INSTALL PAVEMENT MARKINGS PER THE FINAL PAVEMENT MARKING PLANS AND UTILIZE TEMPORARY PAINT.

ETHERILL ENGINEERING
 1223 Jones Franklin Rd.
 Raleigh, N.C. 27606
 License No. F-0377
 Bus: 919 851 8077
 Fax: 919 851 8107

TRANSPORTATION PLANNING/DESIGN - BRIDGE/STRUCTURE DESIGN
 CIVIL/SITE DESIGN - GIS/GPS - CONSTRUCTION OBSERVATION

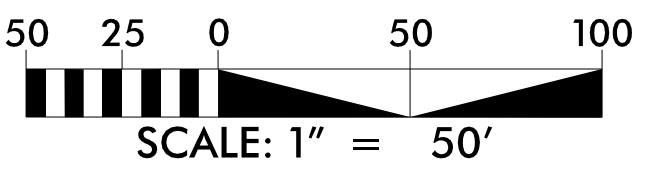

APPROVED: *Bob A. May*
 DATE: 4/19/2022

PROFESSIONAL SEAL
 NORTH CAROLINA
 SEAL 047751
 ENGINEER
 BOB A. MAY

DOCUMENT NOT CONSIDERED FINAL UNLESS ALL SIGNATURES COMPLETED

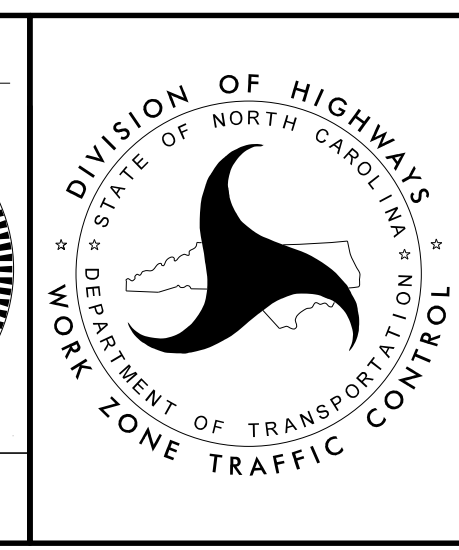

**PHASE II
 PLAN SHEET**

4/19/2022
 P:\2022\175.01-R-4705-Final\Traffic\TMP\Sheets\R-4705-TC-TMP-49_Phil.dgn
 User: phil

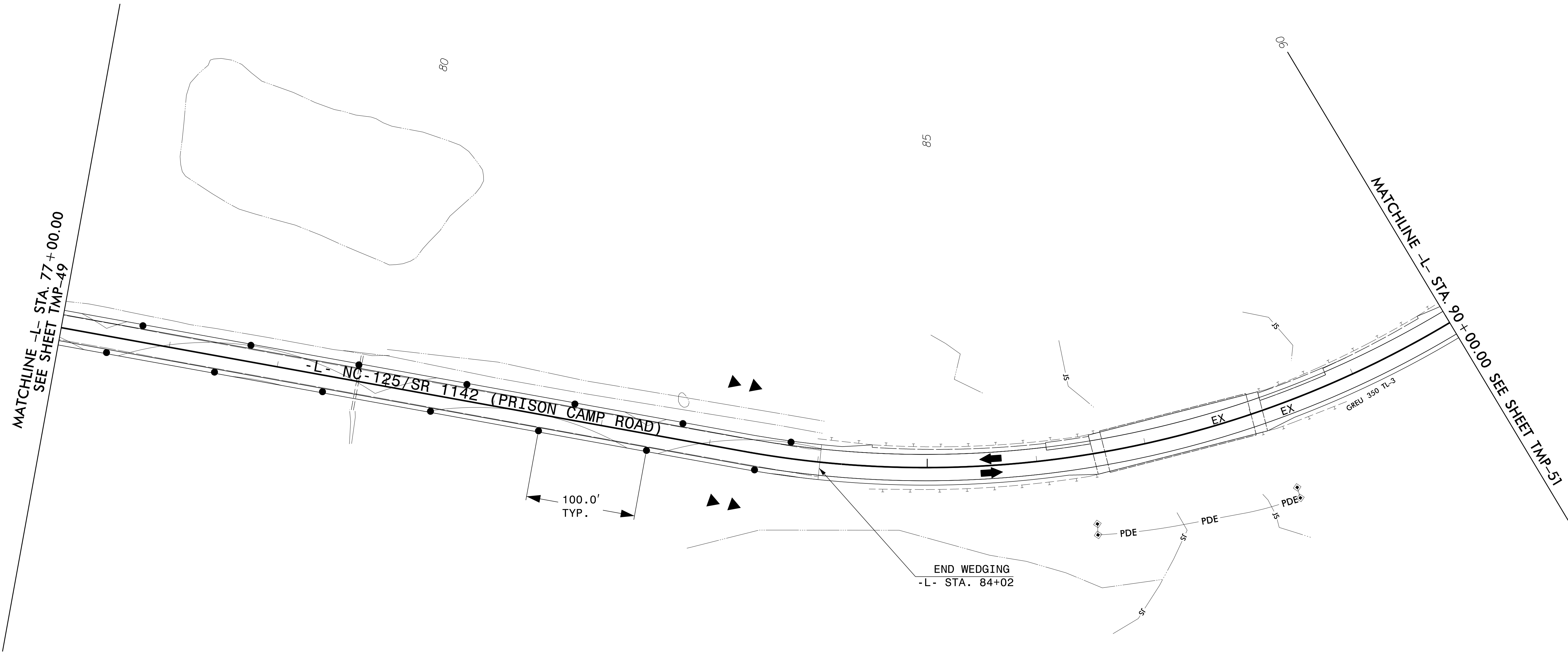
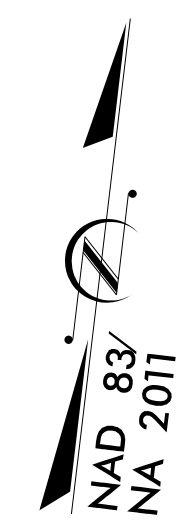

4/19/2022
 P:\2022\7175.01-R-4705-Final\Traffic\WZTC\TMP\Sheets\R-4705_TC_TMP_50_Phil.dgn
 User: phil@es

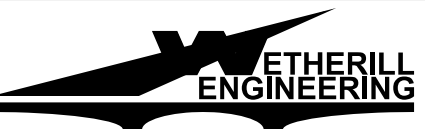

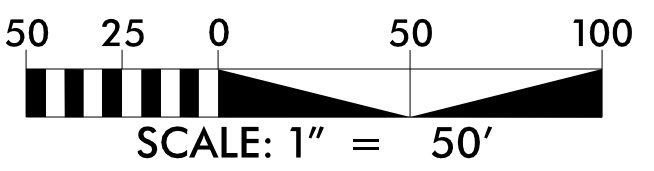
ETHERILL ENGINEERING
 1223 Jones Franklin Rd.
 Raleigh, N.C. 27606
 License No. F-0377
 Bus: 919 851 8077
 Fax: 919 851 8107

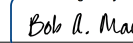

NOTES:

- CONTRACTOR SHALL INSTALL PAVEMENT MARKINGS PER THE FINAL PAVEMENT MARKING PLANS AND UTILIZE TEMPORARY PAINT.

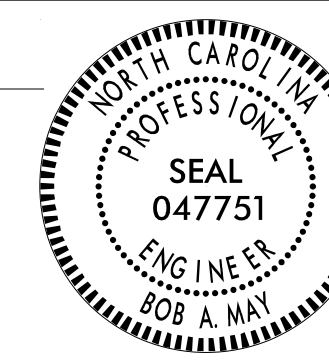
APPROVED: 
 DATE: 4/19/2022



DOCUMENT NOT CONSIDERED FINAL UNLESS ALL SIGNATURES COMPLETED

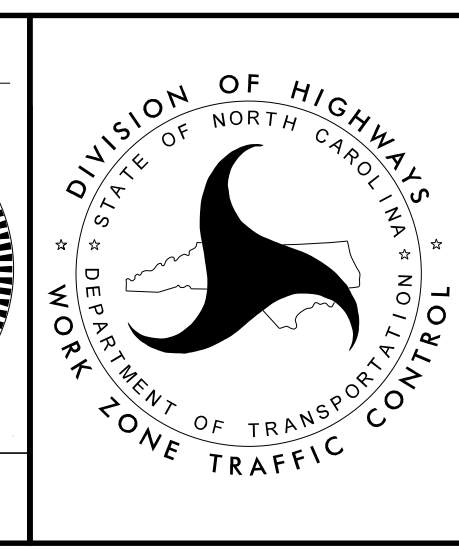

**PHASE II
 PLAN SHEET**

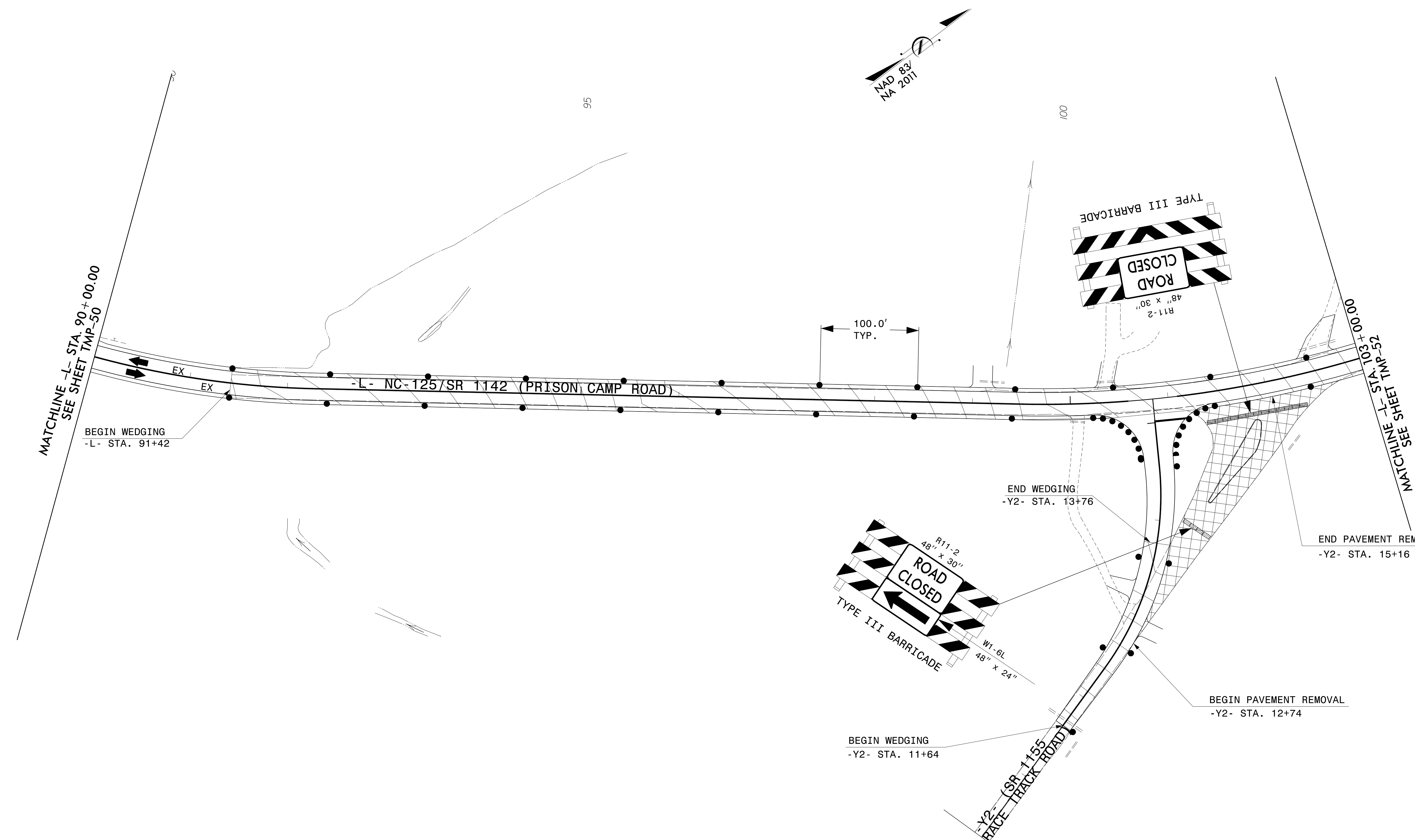

ETHERILL ENGINEERING
 1223 Jones Franklin Rd.
 Raleigh, N.C. 27606
 License No. F-0377
 Bus: 919 851 8077
 Fax: 919 851 8107

TRANSPORTATION PLANNING/DESIGN - BRIDGE/STRUCTURE DESIGN
 CIVIL/SITE DESIGN - GIS/GPS - CONSTRUCTION OBSERVATION

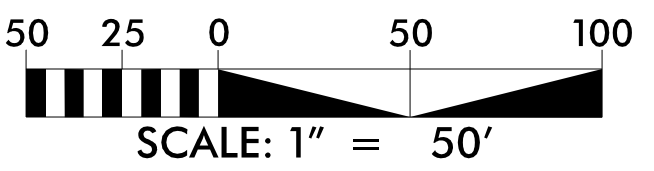

NOTES:

- CONTRACTOR SHALL INSTALL PAVEMENT MARKINGS PER THE FINAL PAVEMENT MARKING PLANS AND UTILIZE TEMPORARY PAINT.

APPROVED: *Bob A. May*
 DATE: 4/19/2022

PROFESSIONAL SEAL
 NORTH CAROLINA
 ENGINEER
 047751
 BOB A. MAY

DOCUMENT NOT CONSIDERED FINAL UNLESS ALL SIGNATURES COMPLETED

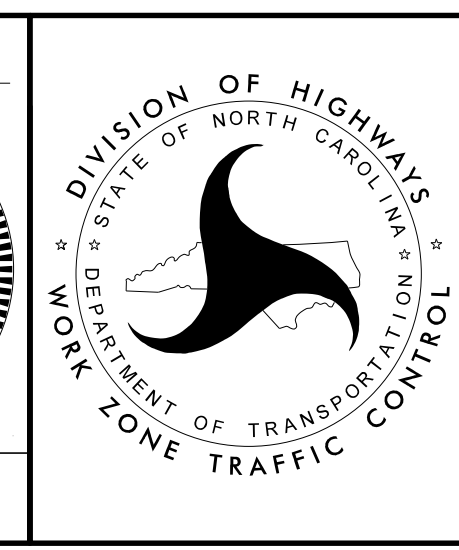

PHASE II PLAN SHEET

4/19/2022
 P:\2022\7175.01_R-4705-Final\Traffic\WZTC\TMP\Sheets\R-4705_TC_TMP_51PHI.dgn
 User: rphillyes

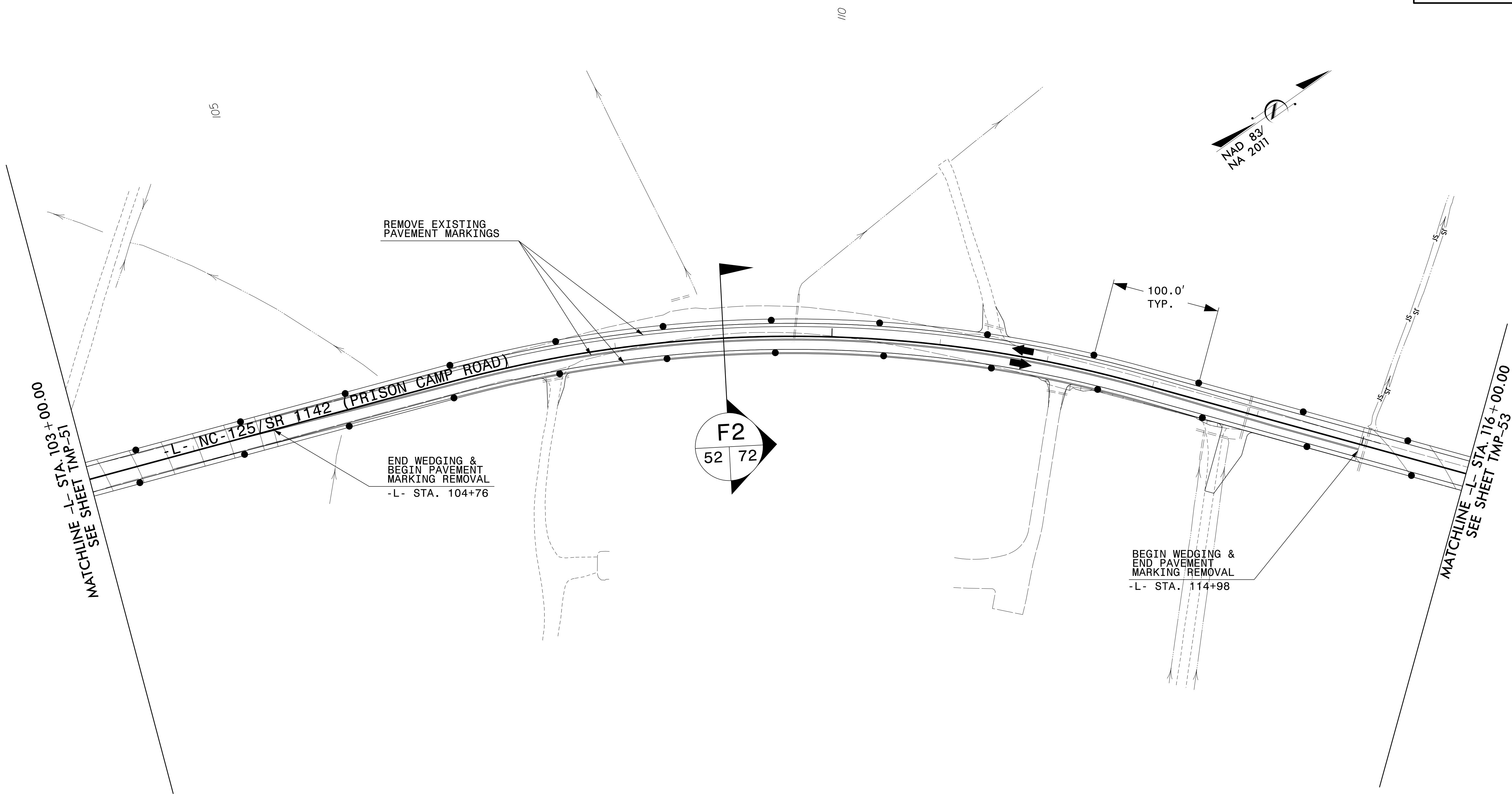

MATCHLINE -L- STA. 103+51
SEE SHEET TMP-51

MATCHLINE -L- STA. 116+00.00
SEE SHEET TMP-53

REMOVE EXISTING PAVEMENT MARKINGS

END WEDGING & BEGIN PAVEMENT MARKING REMOVAL
-L- STA. 104+76

100.0'
TYP.

BEGIN WEDGING & END PAVEMENT MARKING REMOVAL
-L- STA. 114+98

F2
52 72

4/19/2022
 P:\2020\7175.01.R-4705-Final\Traffic\WZTC\TMP\Sheets\R-4705_TC_TMP_52_Phil.dgn
 User: phil

ETHERILL ENGINEERING
 1223 Jones Franklin Rd.
 Raleigh, N.C. 27606
 License No. F-0377
 Bus: 919 851 8077
 Fax: 919 851 8107

TRANSPORTATION PLANNING/DESIGN - BRIDGE/STRUCTURE DESIGN
 CIVIL/SITE DESIGN - GIS/GPS - CONSTRUCTION OBSERVATION

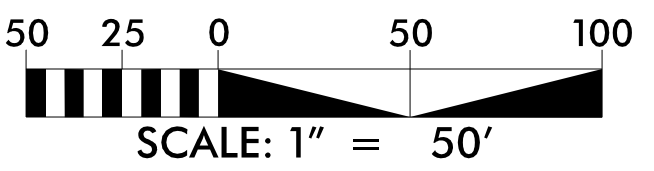

NOTES:

- CONTRACTOR SHALL INSTALL PAVEMENT MARKINGS PER THE FINAL PAVEMENT MARKING PLANS AND UTILIZE TEMPORARY PAINT.

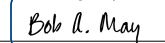
APPROVED: 
 DATE: 4/19/2022



**DOCUMENT NOT CONSIDERED FINAL
UNLESS ALL SIGNATURES COMPLETED**

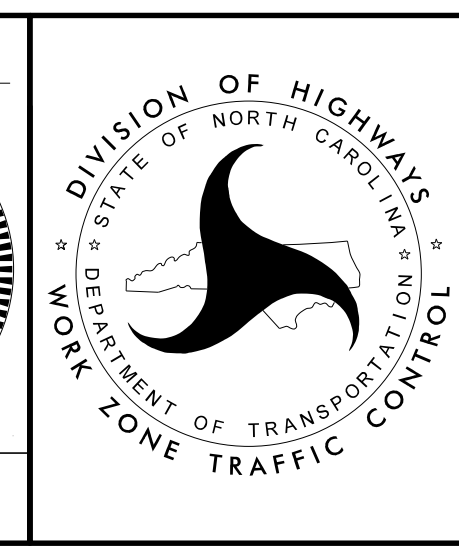

**PHASE II
PLAN SHEET**

MATCHLINE -L- STA. 116+00.00
SEE SHEET TMP-52

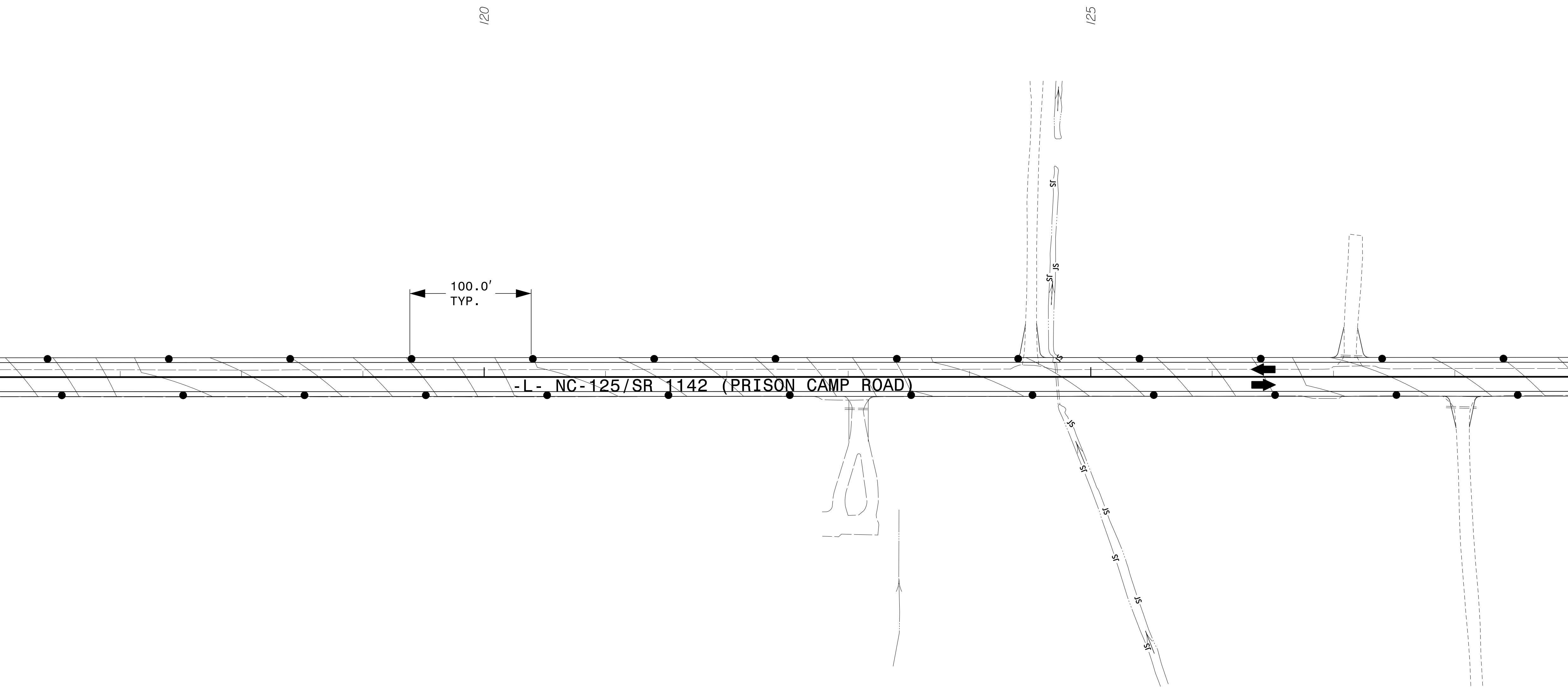

MATCHLINE -L- STA. 129+00.00
SEE SHEET TMP-54

NOTES:

- CONTRACTOR SHALL INSTALL PAVEMENT MARKINGS PER THE FINAL PAVEMENT MARKING PLANS AND UTILIZE TEMPORARY PAINT.

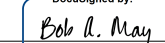
APPROVED: 
DATE: 4/19/2022



**DOCUMENT NOT CONSIDERED FINAL
UNLESS ALL SIGNATURES COMPLETED**

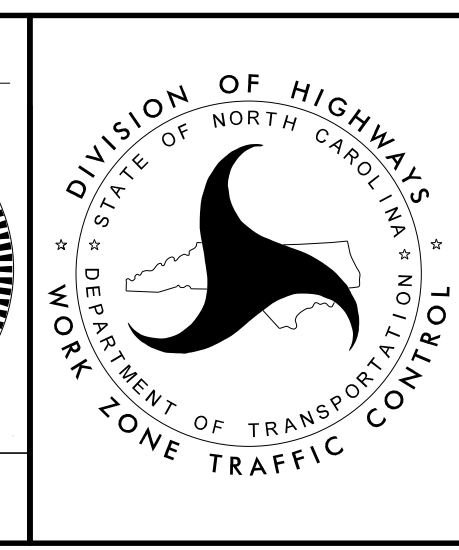

**PHASE II
PLAN SHEET**

4/19/2022
P:\2022\175.01-R-4705-Final\Traffic\WZTC\TMP\Sheets\R-4705_TC_TMP_53_Phil.dgn
User: philc

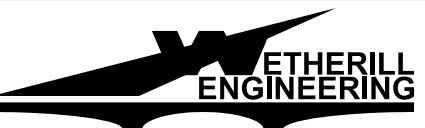

1223 Jones Franklin Rd.
Raleigh, N.C. 27606
License No. F-0377
Bus: 919 851 8077
Fax: 919 851 8107

TRANSPORTATION PLANNING/DESIGN - BRIDGE/STRUCTURE DESIGN
CIVIL/SITE DESIGN - GIS/GPS - CONSTRUCTION OBSERVATION

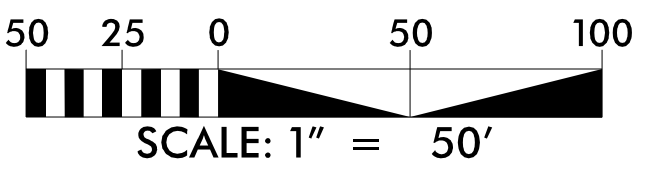

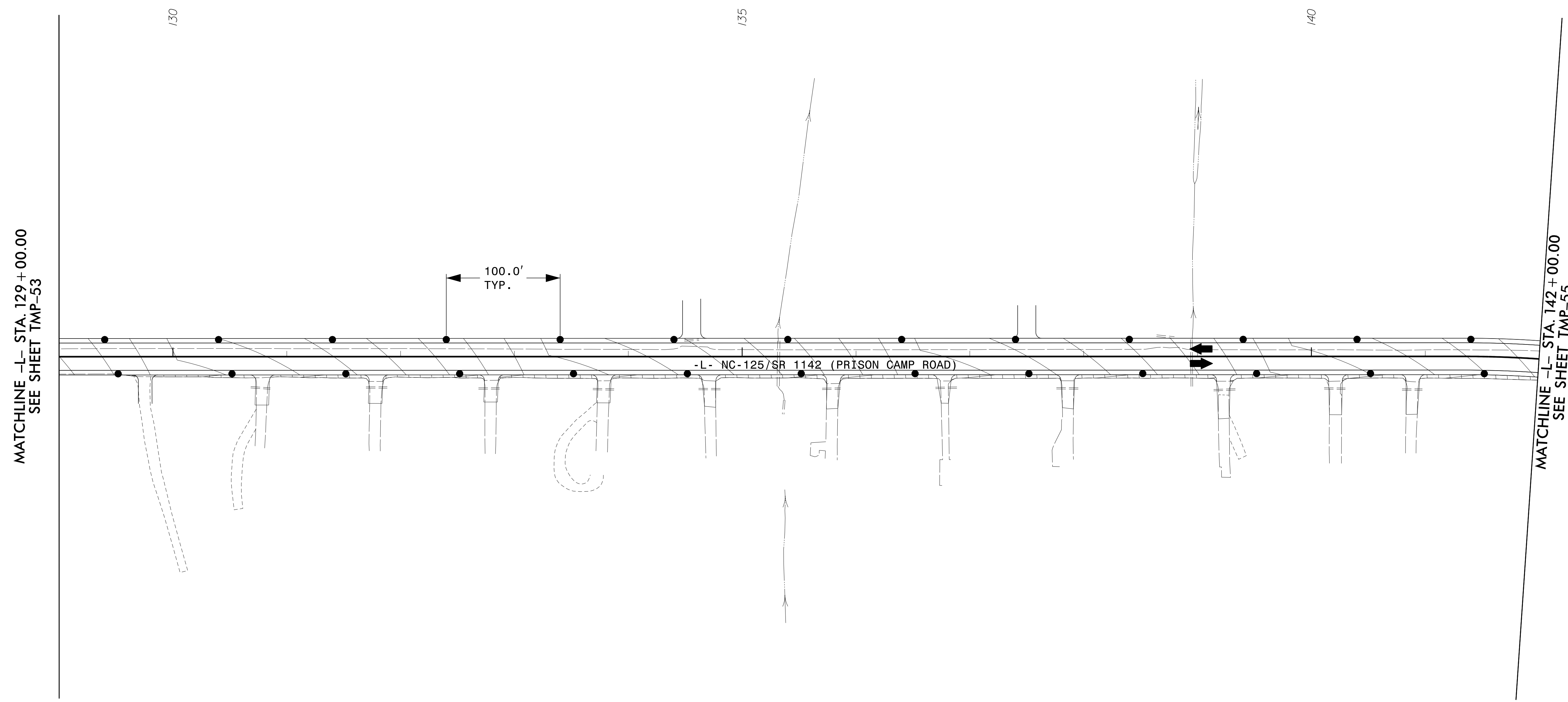

MATCHLINE -L- STA. 129+00.00
SEE SHEET TMP-53

MATCHLINE -L- STA. 142+00.00
SEE SHEET TMP-55

-L- NC-125/SR 1142 (PRISON CAMP ROAD)

100.0'
TYP.

130

135

140

4/19/2022
 P:\2022\7175.01_R-4705-Final\Traffic\WZTC\TMP\Sheets\R-4705_TC_TMP_54_Phil.dgn
 User: phil

1223 Jones Franklin Rd.
 Raleigh, N.C. 27606
 License No. F-0377
 Bus: 919 851 8077
 Fax: 919 851 8107

TRANSPORTATION PLANNING/DESIGN - BRIDGE/STRUCTURE DESIGN
 CIVIL/SITE DESIGN - GIS/GPS - CONSTRUCTION OBSERVATION

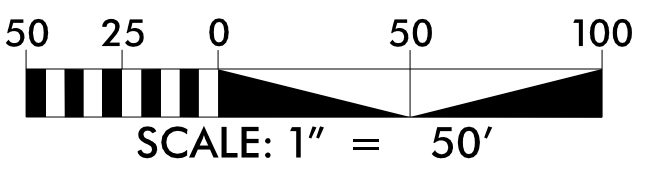

NOTES:

- CONTRACTOR SHALL INSTALL PAVEMENT MARKINGS PER THE FINAL PAVEMENT MARKING PLANS AND UTILIZE TEMPORARY PAINT.

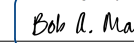
APPROVED: 

DATE: 4/19/2022



**DOCUMENT NOT CONSIDERED FINAL
UNLESS ALL SIGNATURES COMPLETED**

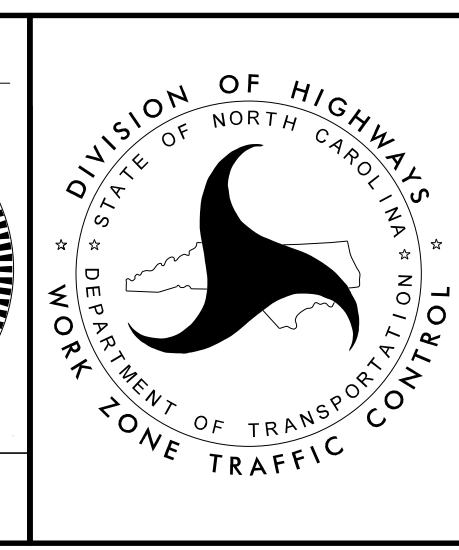

**PHASE II
PLAN SHEET**

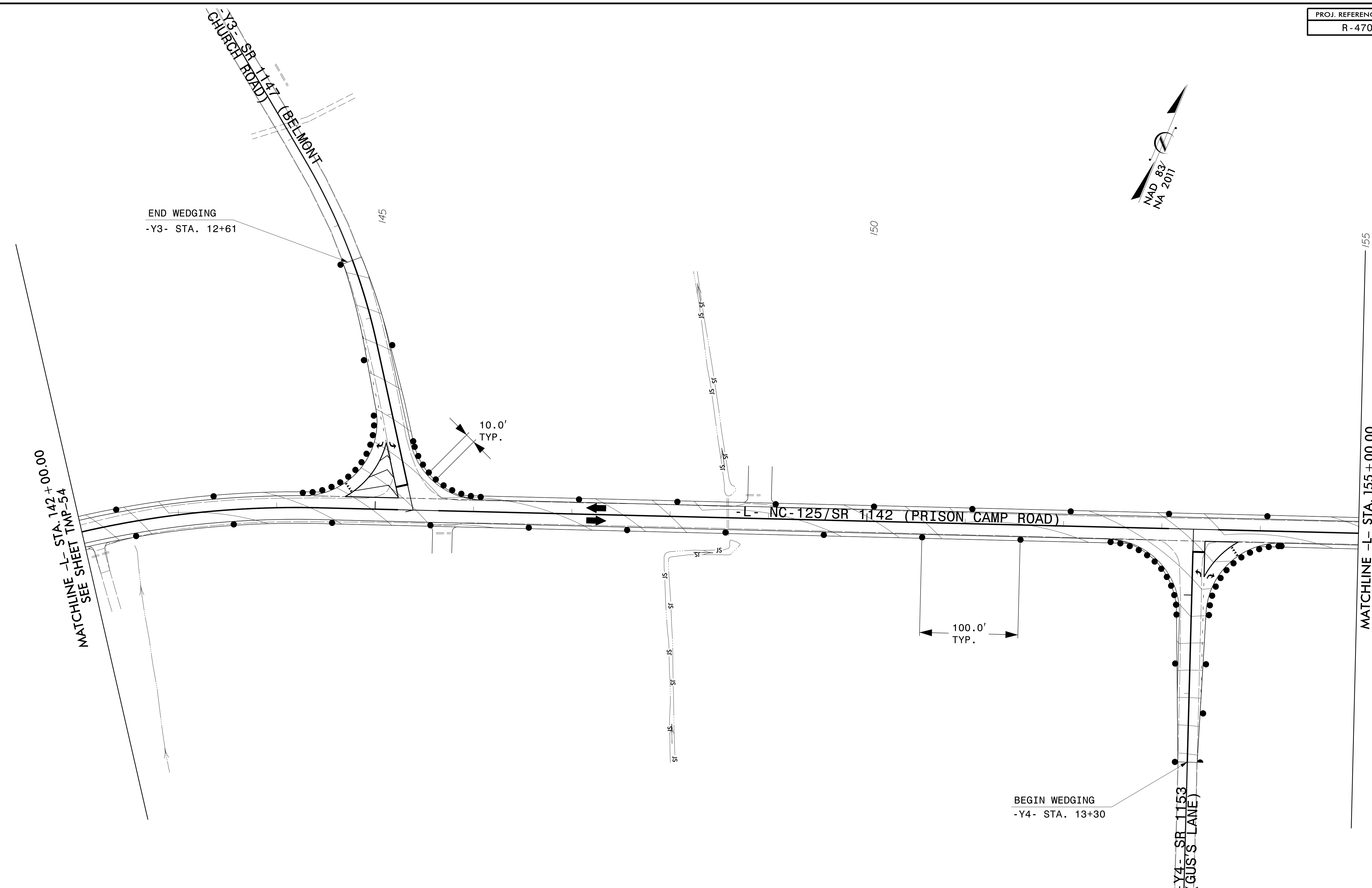

MATCHLINE -L- STA. 142 + 00.00
SEE SHEET TMP-54

MATCHLINE -L- STA. 155 + 00.00
SEE SHEET TMP-56

END WEDGING
-Y3- STA. 12+61

BEGIN WEDGING
-Y4- STA. 13+30

10.0'
TYP.

100.0'
TYP.

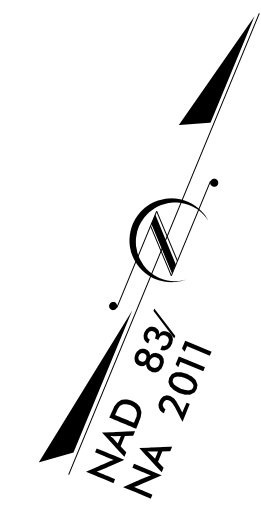

4/19/2022
 P:\2020\175.01-R-4705-Final\Traffic\WZTC\TMP\Sheets\R-4705_TC_TMP_55_Phil.dgn
 User: phil

ETHERILL ENGINEERING
 1223 Jones Franklin Rd.
 Raleigh, N.C. 27606
 License No. F-0377
 Bus: 919 851 8077
 Fax: 919 851 8107

TRANSPORTATION PLANNING/DESIGN - BRIDGE/STRUCTURE DESIGN
 CIVIL/SITE DESIGN - GIS/GPS - CONSTRUCTION OBSERVATION

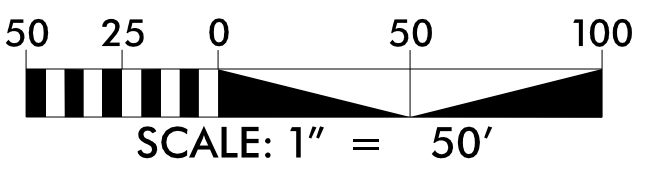

NOTES:
 - CONTRACTOR SHALL INSTALL PAVEMENT MARKINGS PER THE FINAL PAVEMENT MARKING PLANS AND UTILIZE TEMPORARY PAINT.

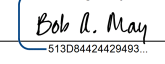
APPROVED: 
 DATE: 4/19/2022



**DOCUMENT NOT CONSIDERED FINAL
 UNLESS ALL SIGNATURES COMPLETED**

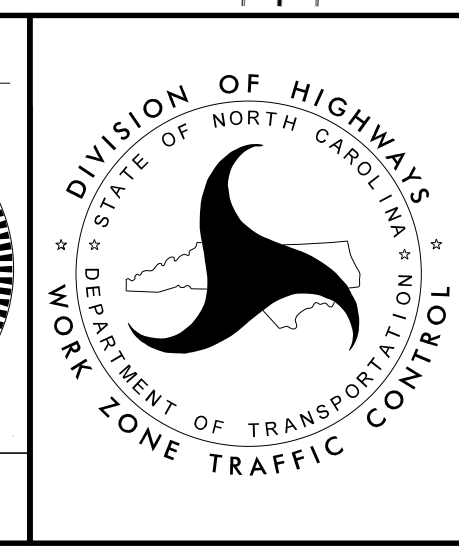

**PHASE II
 PLAN SHEET**

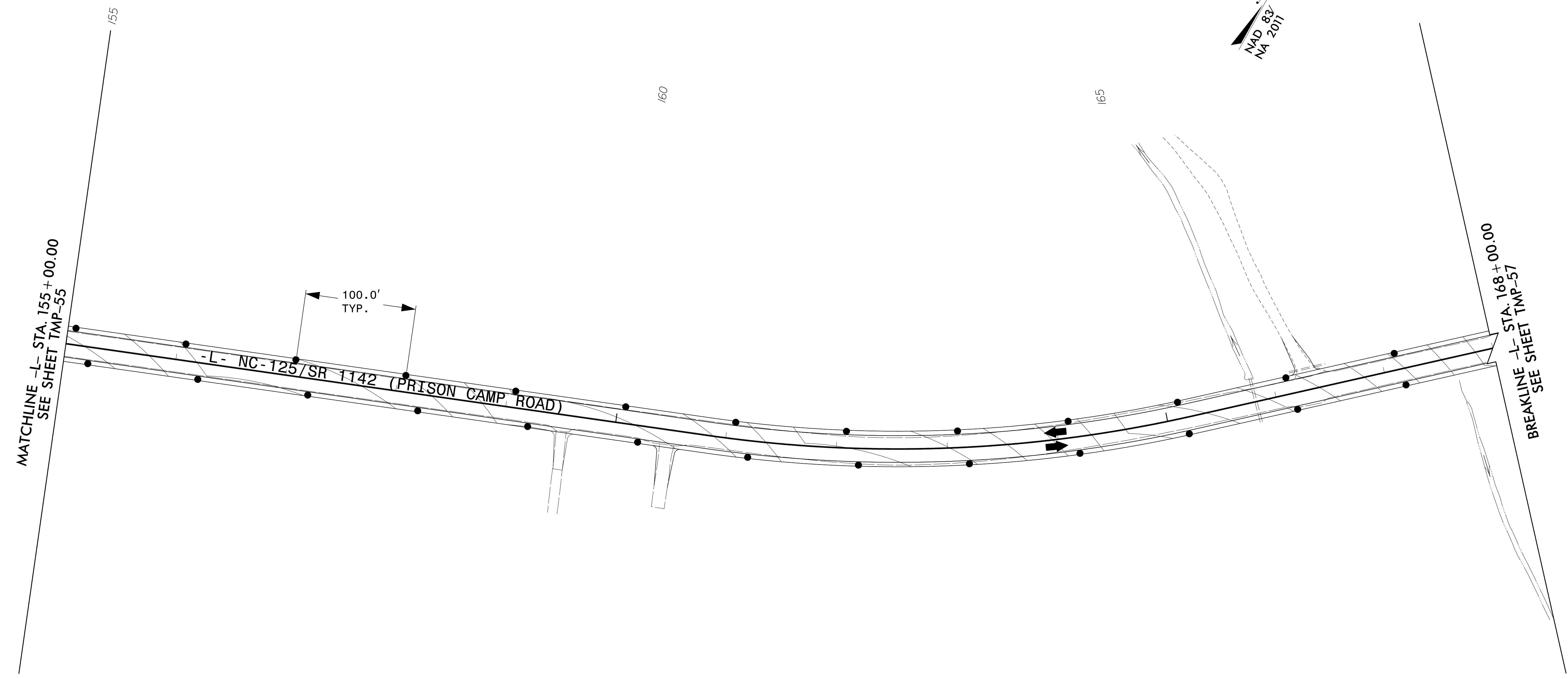

4/19/2022
 P:\2022\7175.01_R-4705-Final\Traffic\WZTC\TMP\Sheets\R-4705_TC_TMP_56_Phil.dgn
 User: phil@es

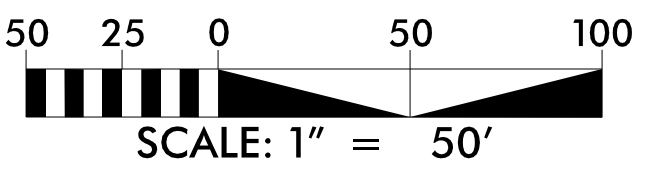

ETHERILL ENGINEERING
 1223 Jones Franklin Rd.
 Raleigh, N.C. 27606
 License No. F-0377
 Bus: 919 851 8077
 Fax: 919 851 8107

TRANSPORTATION PLANNING/DESIGN - BRIDGE/STRUCTURE DESIGN
 CIVIL/SITE DESIGN - GIS/GPS - CONSTRUCTION OBSERVATION

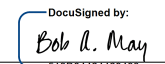

NOTES:

- CONTRACTOR SHALL INSTALL PAVEMENT MARKINGS PER THE FINAL PAVEMENT MARKING PLANS AND UTILIZE TEMPORARY PAINT.

APPROVED: 
 DATE: 4/19/2022



DOCUMENT NOT CONSIDERED FINAL UNLESS ALL SIGNATURES COMPLETED

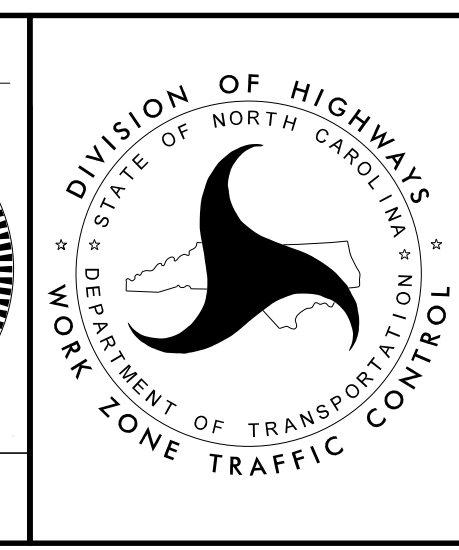

**PHASE II
 PLAN SHEET**

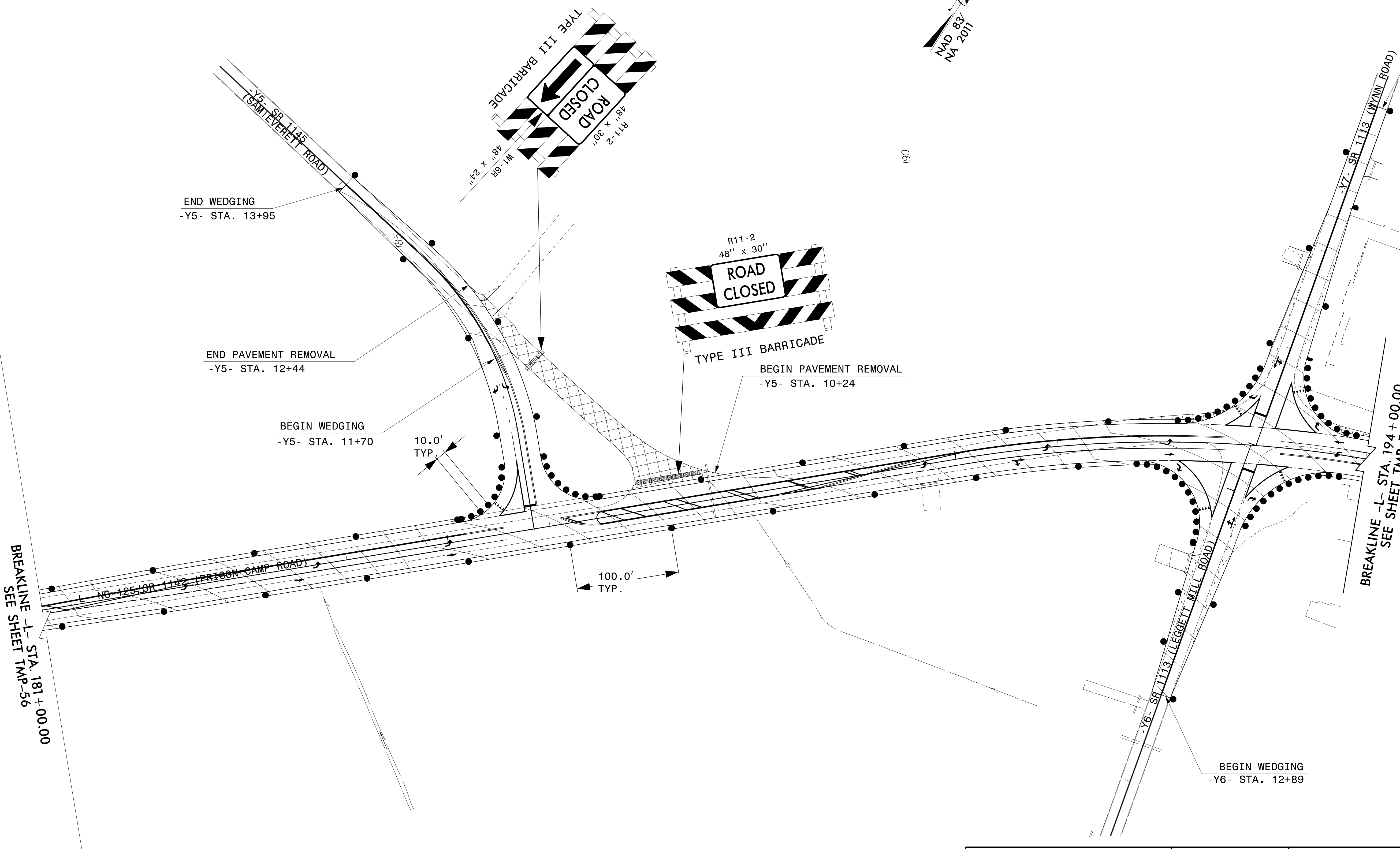
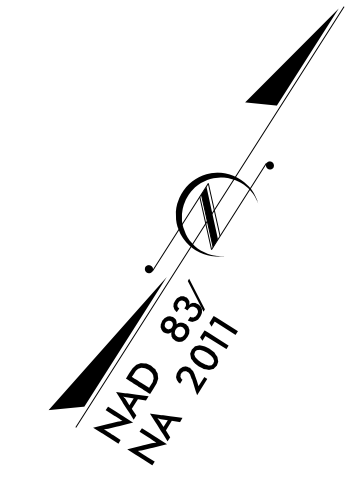

BREAKLINE -L- STA. 181+00.00
SEE SHEET TMP-56

BREAKLINE -L- STA. 194+00.00
SEE SHEET TMP-58

NOTES:
- CONTRACTOR SHALL INSTALL PAVEMENT MARKINGS PER THE FINAL PAVEMENT MARKING PLANS AND UTILIZE TEMPORARY PAINT.

ETHERILL ENGINEERING
1223 Jones Franklin Rd.
Raleigh, N.C. 27606
License No. F-0377
Bus: 919 851 8077
Fax: 919 851 8107

TRANSPORTATION PLANNING/DESIGN - BRIDGE/STRUCTURE DESIGN
CIVIL/SITE DESIGN - GIS/GPS - CONSTRUCTION OBSERVATION

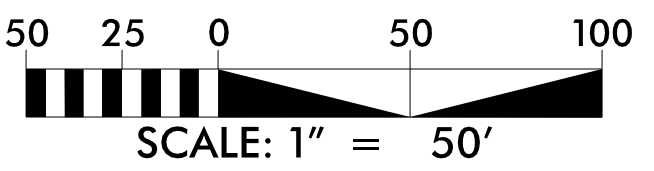

APPROVED: *Bob A. May*
DATE: 4/19/2022

**DOCUMENT NOT CONSIDERED FINAL
UNLESS ALL SIGNATURES COMPLETED**

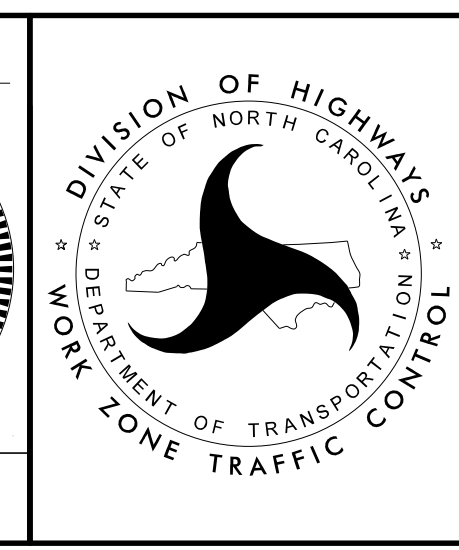

**PHASE II
PLAN SHEET**

4/19/2022
P:\2022\175.01-R-4705-Final\Traffic\WZTC\TMP\Sheets\R-4705_TC_TMP_57_Phil.dgn
User: rathayes

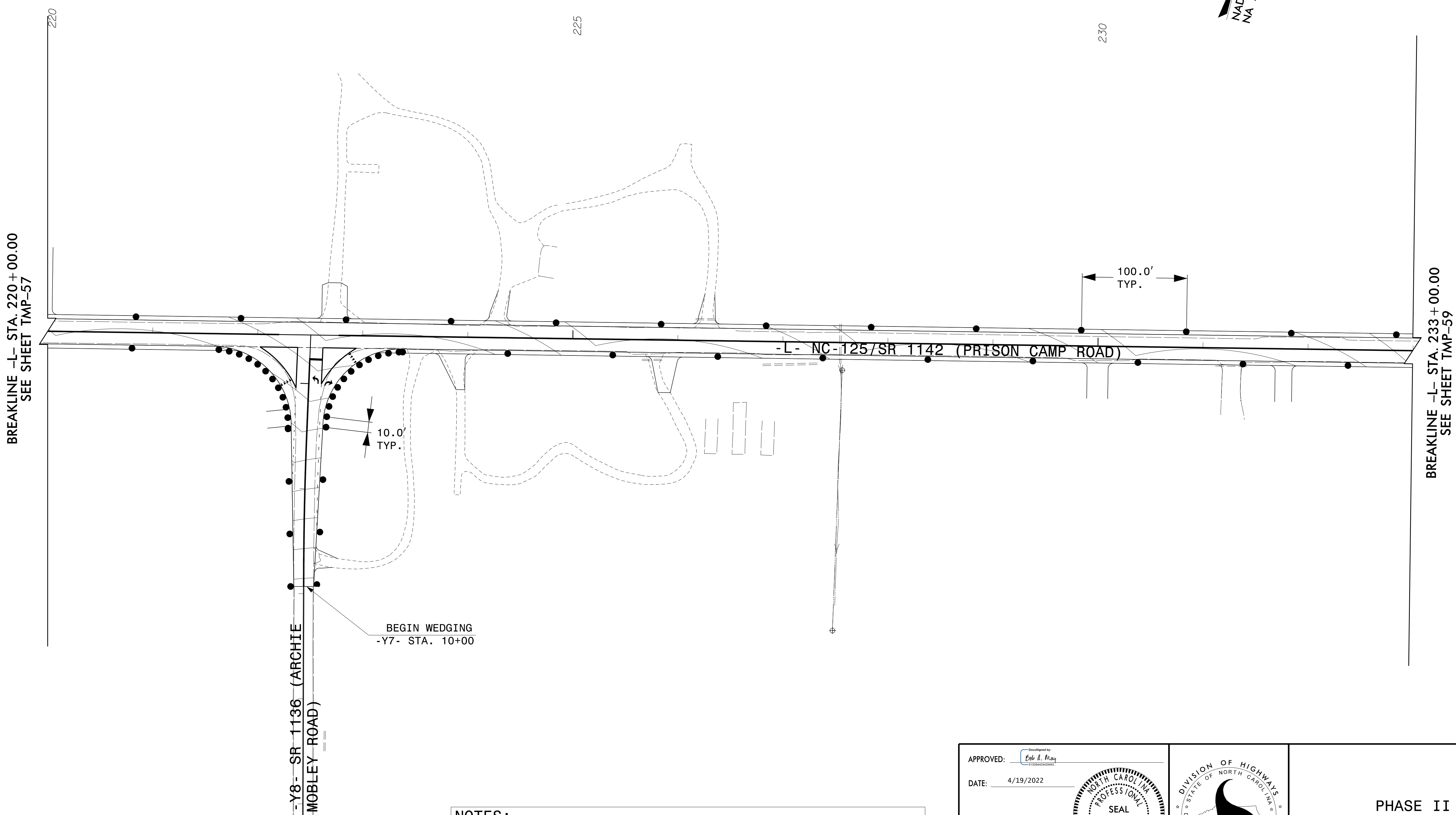

4/19/2022
 P:\2022\175.01-R-4705-Final\Traffic\WZTC\TMP\Sheets\R-4705_TC_TMP_58_Phil.dgn
 User: phil

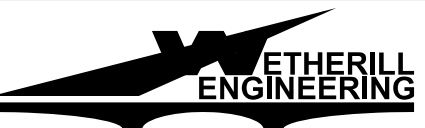

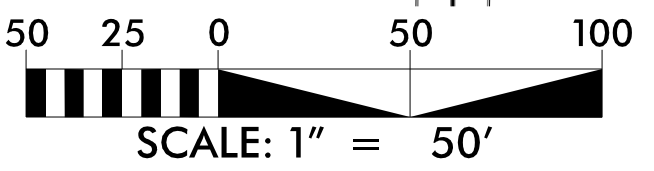
ETHERILL ENGINEERING
 1223 Jones Franklin Rd.
 Raleigh, N.C. 27606
 License No. F-0377
 Bus: 919 851 8077
 Fax: 919 851 8107

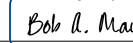

NOTES:

- CONTRACTOR SHALL INSTALL PAVEMENT MARKINGS PER THE FINAL PAVEMENT MARKING PLANS AND UTILIZE TEMPORARY PAINT.

APPROVED: 
 DATE: 4/19/2022



DOCUMENT NOT CONSIDERED FINAL UNLESS ALL SIGNATURES COMPLETED

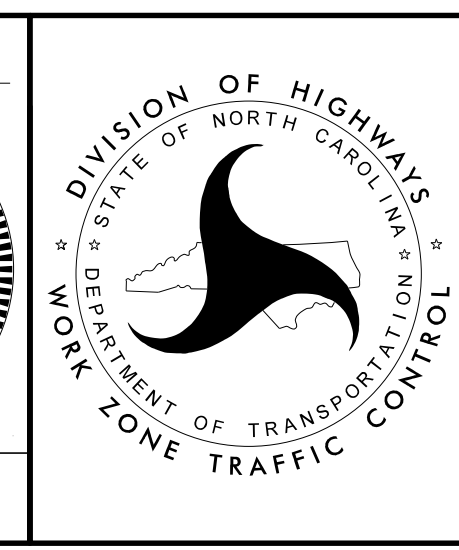

**PHASE II
 PLAN SHEET**

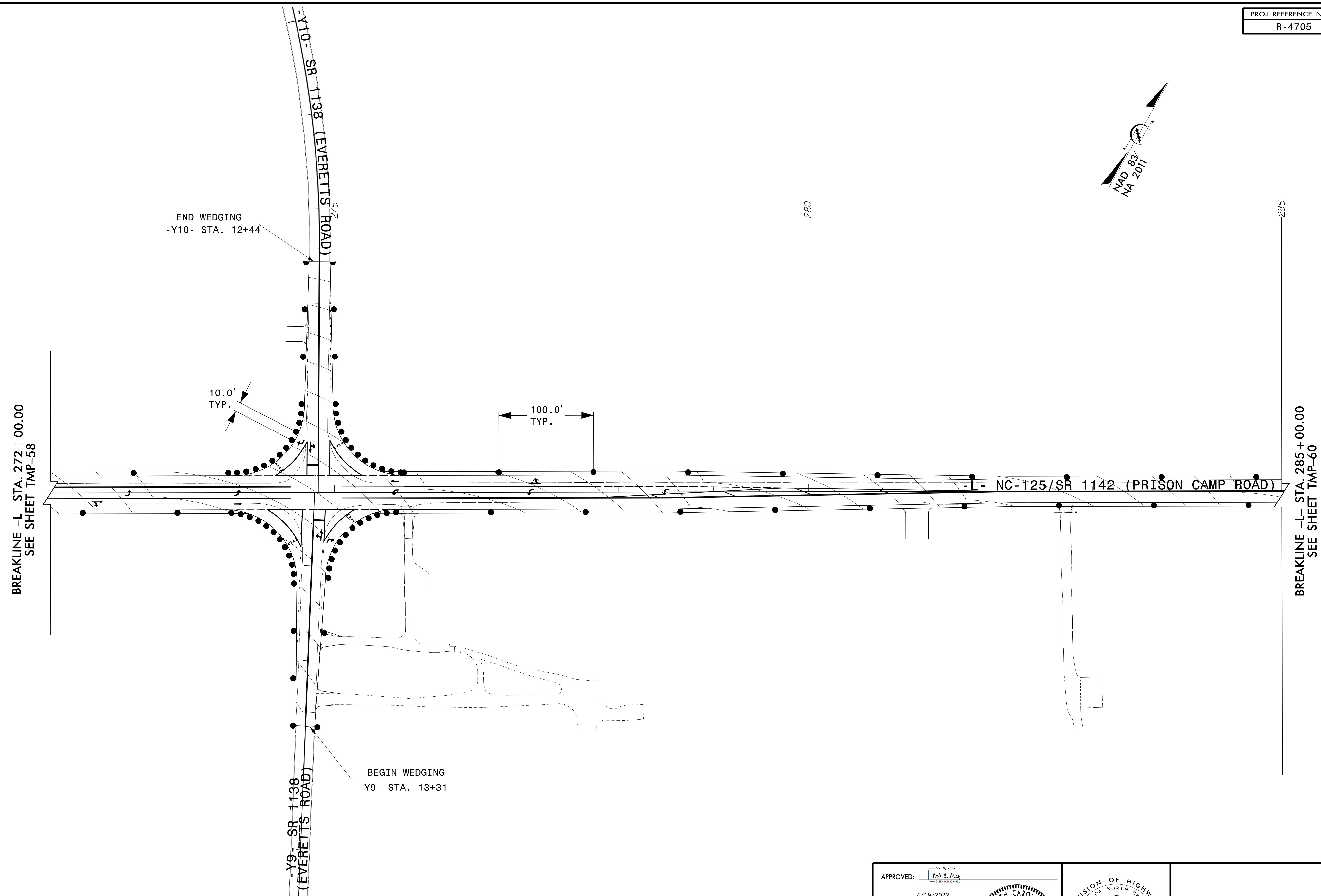
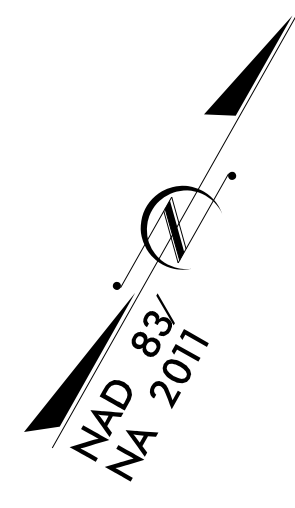

BREAKLINE -L- STA. 272+00.00
SEE SHEET TMP-58

BREAKLINE -L- STA. 285+00.00
SEE SHEET TMP-60

END WEDGING
-Y10- STA. 12+44

10.0'
TYP.

100.0'
TYP.

BEGIN WEDGING
-Y9- STA. 13+31

4/19/2022
P:\2022\175.01-R-4705-Final\Traffic\WZTC\TMP\Sheets\R-4705-TC-TMP-59 PHII.dgn
User: r141414

ETHERILL ENGINEERING
 1223 Jones Franklin Rd.
 Raleigh, N.C. 27606
 License No. F-0377
 Bus: 919 851 8077
 Fax: 919 851 8107

TRANSPORTATION PLANNING/DESIGN - BRIDGE/STRUCTURE DESIGN
 CIVIL/SITE DESIGN - GIS/GPS - CONSTRUCTION OBSERVATION

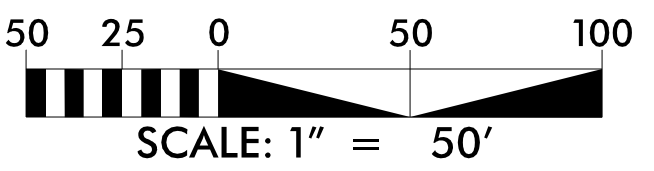

NOTES:

- CONTRACTOR SHALL INSTALL PAVEMENT MARKINGS PER THE FINAL PAVEMENT MARKING PLANS AND UTILIZE TEMPORARY PAINT.

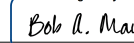
APPROVED: 
 DATE: 4/19/2022

PROFESSIONAL SEAL
 NORTH CAROLINA
 SEAL 047751
 ENGINEER
 BOB A. MAY

**DOCUMENT NOT CONSIDERED FINAL
 UNLESS ALL SIGNATURES COMPLETED**

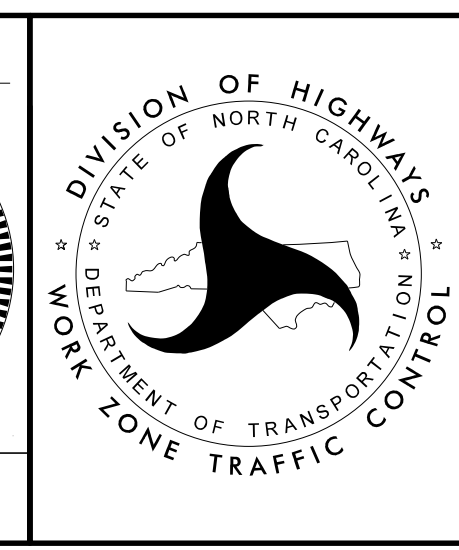

**PHASE II
 PLAN SHEET**

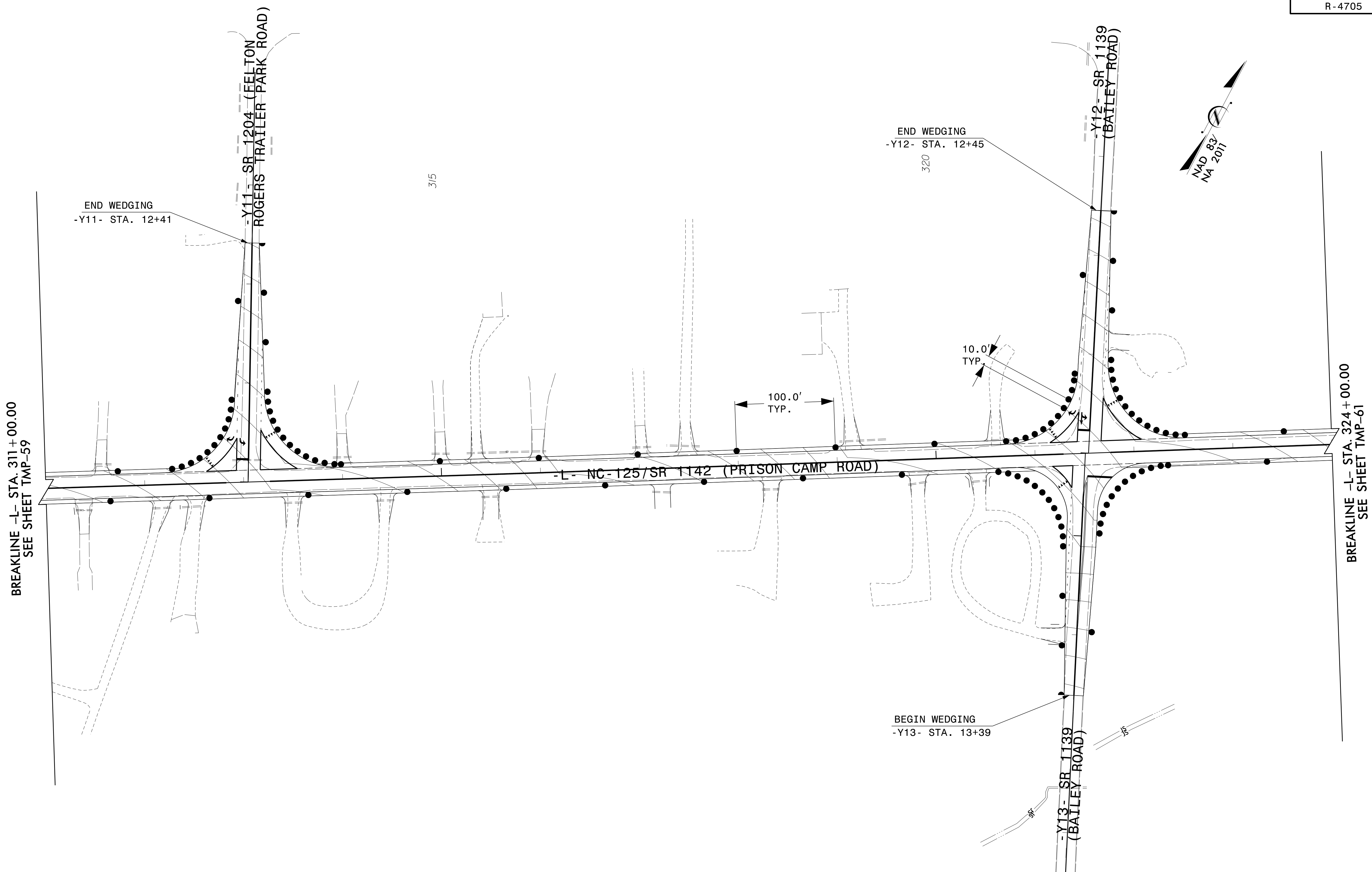

BREAKLINE -L- STA. 311 + 00.00
SEE SHEET TMP-59

BREAKLINE -L- STA. 324 + 00.00
SEE SHEET TMP-61

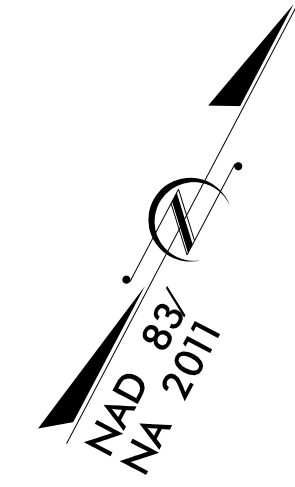

NOTES:

- CONTRACTOR SHALL INSTALL PAVEMENT MARKINGS PER THE FINAL PAVEMENT MARKING PLANS AND UTILIZE TEMPORARY PAINT.

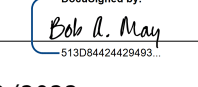
APPROVED: 
 DATE: 4/19/2022

**DOCUMENT NOT CONSIDERED FINAL
UNLESS ALL SIGNATURES COMPLETED**

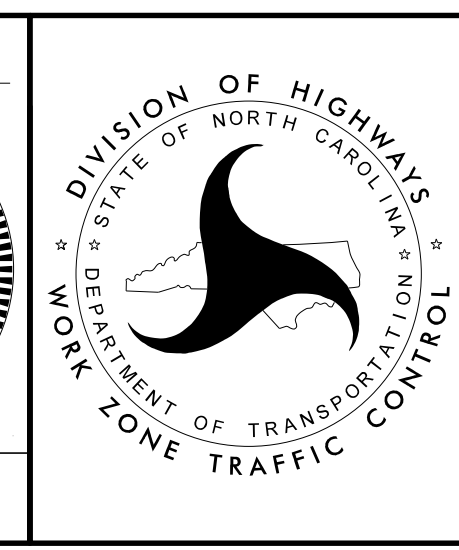

PHASE II
PLAN SHEET

ETHERILL ENGINEERING
 1223 Jones Franklin Rd.
 Raleigh, N.C. 27606
 License No. F-0377
 Bus: 919 851 8077
 Fax: 919 851 8107

TRANSPORTATION PLANNING/DESIGN - BRIDGE/STRUCTURE DESIGN
 CIVIL/SITE DESIGN - GIS/GPS - CONSTRUCTION OBSERVATION

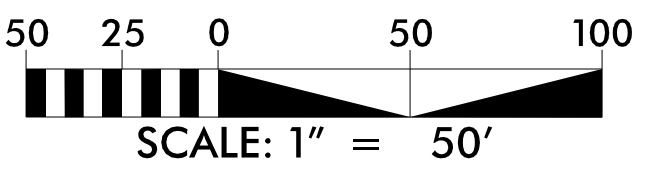

4/19/2022
P:\2022\175.01-R-4705-Final\Traffic\WZTC\TMP\Sheets\R-4705_TC_TMP_60_Phil.dgn
User: phil

BREAKLINE -L- STA. 350+00.00
SEE SHEET TMP-60

350

355

360

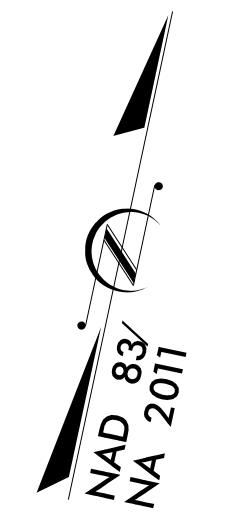

END WEDGING & BEGIN REMOVAL
OF EXISTING PAVEMENT MARKINGS
-L- STA. 354+65

BEGIN WEDGING & END REMOVAL OF
EXISTING PAVEMENT MARKINGS
-L- STA. 357+56

L- NC-125/SR 1142 (PRISON CAMP ROAD)

MATCHLINE -L- STA. 363+00.00
SEE SHEET TMP-62

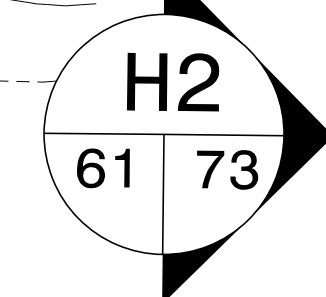

100.0'

10.0'
TYP.

REMOVE EXISTING
PAVEMENT MARKINGS

BEGIN WEDGING
-Y15- STA. 13+15

PIPE PASSES THROUGH
TOP ELEV=71.95'
BOTTOM ELEV=72.33'

-Y15- SR 1106 (ED'S GROCERY ROAD)

NOTES:

- CONTRACTOR SHALL INSTALL PAVEMENT MARKINGS PER THE FINAL PAVEMENT MARKING PLANS AND UTILIZE TEMPORARY PAINT.

4/19/2022
P:\2020\175.01_R-4705-Final\Traffic\WZTC\TMP\Sheets\R-4705_TC_TMP_61.Phil.dgn
User:phil

ETHERILL ENGINEERING
1223 Jones Franklin Rd.
Raleigh, N.C. 27606
License No. F-0377
Bus: 919 851 8077
Fax: 919 851 8107

TRANSPORTATION PLANNING/DESIGN - BRIDGE/STRUCTURE DESIGN
CIVIL/SITE DESIGN - GIS/GPS - CONSTRUCTION OBSERVATION

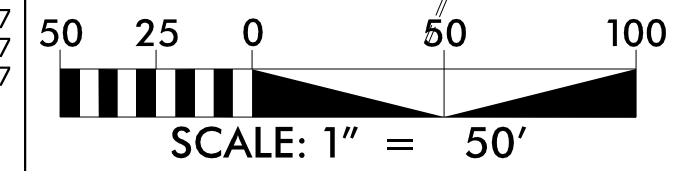

APPROVED: *Bob A. May*
DATE: 4/19/2022

PROFESSIONAL SEAL
047751
ENGINEER
BOB A. MAY

**DOCUMENT NOT CONSIDERED FINAL
UNLESS ALL SIGNATURES COMPLETED**

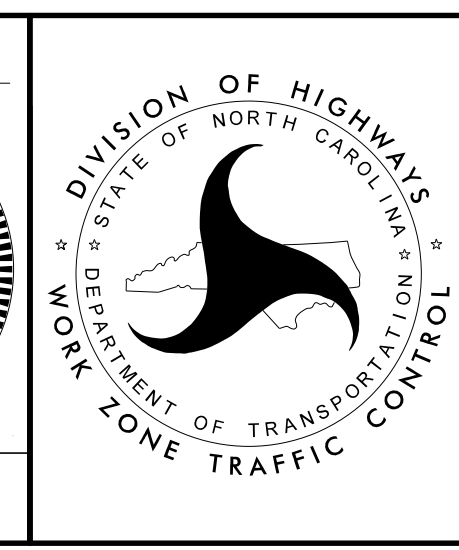

PHASE II
PLAN SHEET

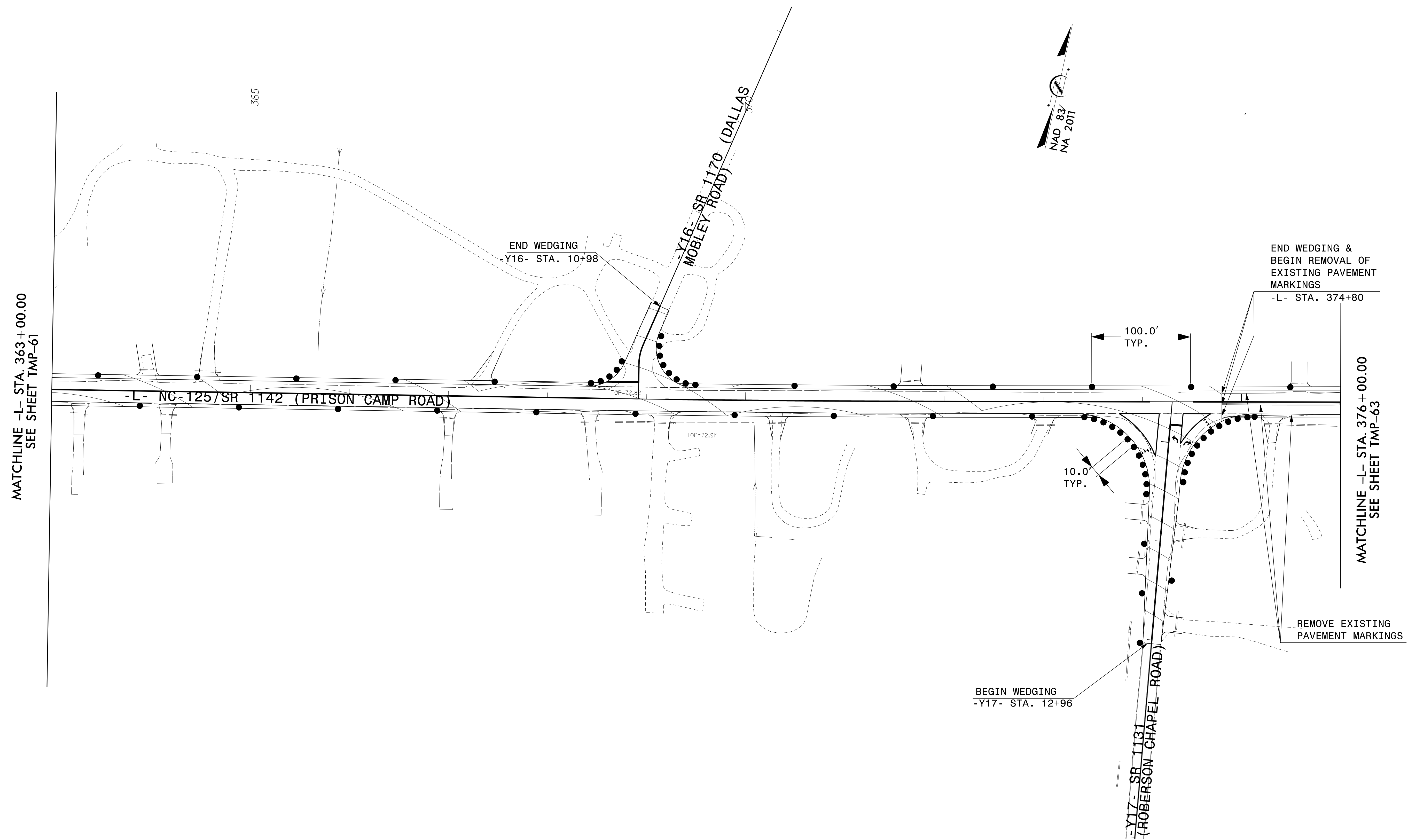



MATCHLINE -L- STA. 363+00.00
SEE SHEET TMP-61

MATCHLINE -L- STA. 376+00.00
SEE SHEET TMP-63

NOTES:

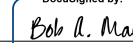
- CONTRACTOR SHALL INSTALL PAVEMENT MARKINGS PER THE FINAL PAVEMENT MARKING PLANS AND UTILIZE TEMPORARY PAINT.

APPROVED: 
DATE: 4/19/2022



**DOCUMENT NOT CONSIDERED FINAL
UNLESS ALL SIGNATURES COMPLETED**

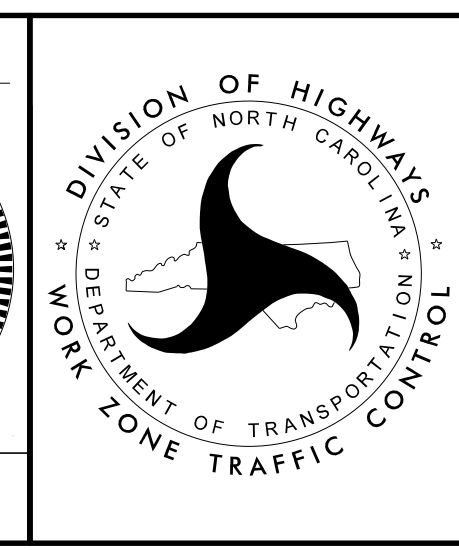

**PHASE II
PLAN SHEET**

4/19/2022
P:\2022\175.01-R-4705-Final\Traffic\WZTC\TMP\Sheets\R-4705_TC_TMP_62_Phil.dgn
User: philc

1223 Jones Franklin Rd.
Raleigh, N.C. 27606
License No. F-0377
Bus: 919 851 8077
Fax: 919 851 8107

TRANSPORTATION PLANNING/DESIGN - BRIDGE/STRUCTURE DESIGN
CIVIL/SITE DESIGN - GIS/GPS - CONSTRUCTION OBSERVATION

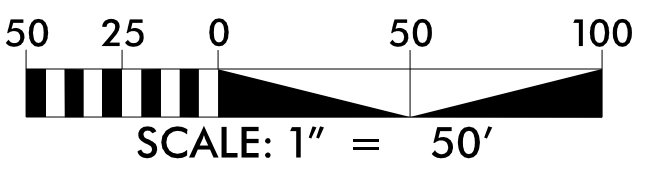

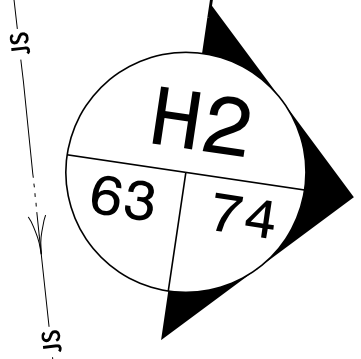
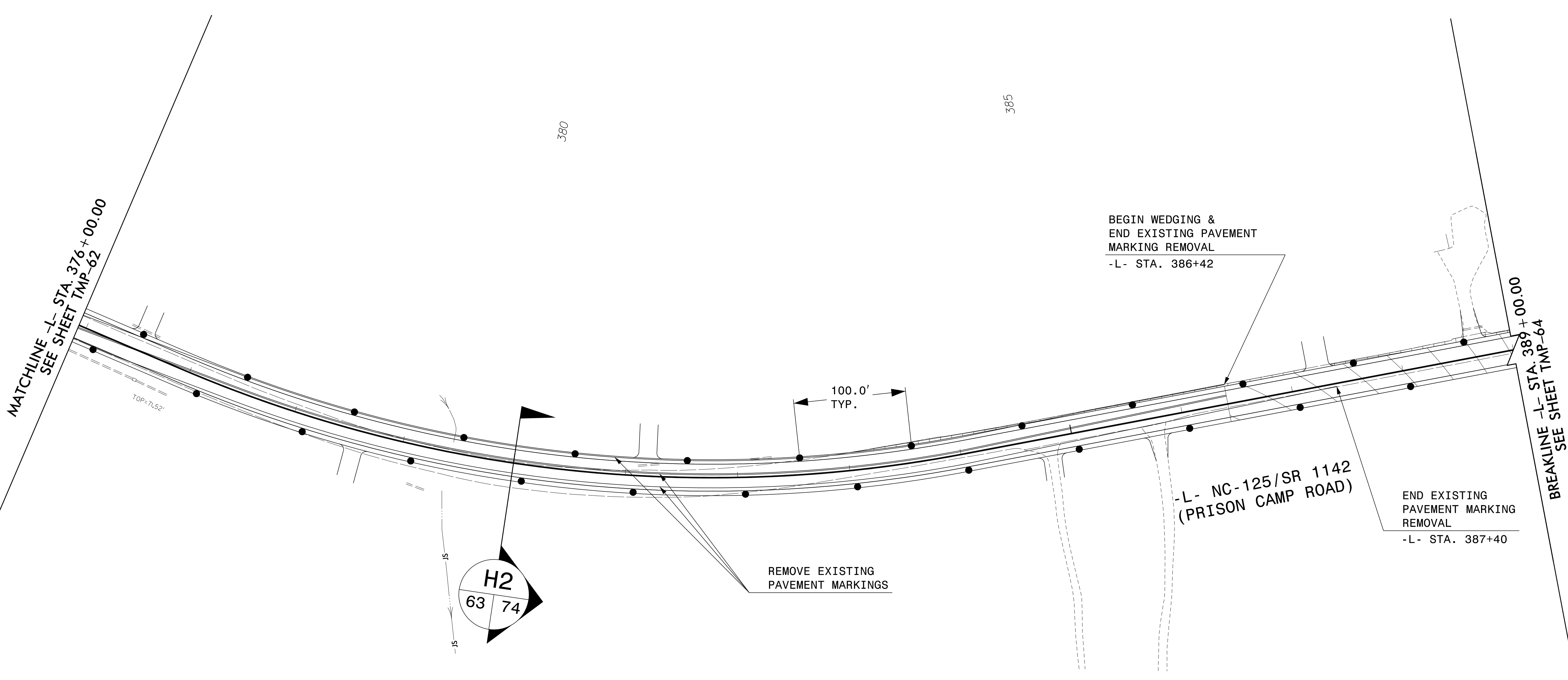
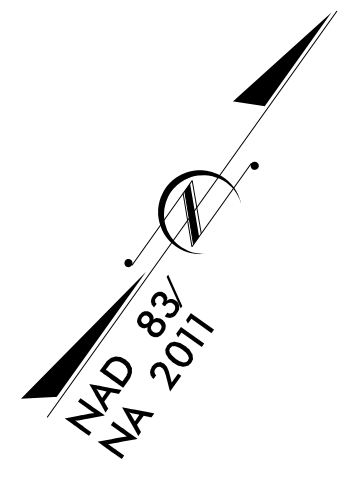

NOTES:

- CONTRACTOR SHALL INSTALL PAVEMENT MARKINGS PER THE FINAL PAVEMENT MARKING PLANS AND UTILIZE TEMPORARY PAINT.

4/19/2022
 P:\2020\7175.01_R-4705-Final\Traffic\WZTC\TMP\Sheets\R-4705_TC_TMP_63_Phil.dgn
 User: philc

ETHERILL ENGINEERING
 1223 Jones Franklin Rd.
 Raleigh, N.C. 27606
 License No. F-0377
 Bus: 919 851 8077
 Fax: 919 851 8107

TRANSPORTATION PLANNING/DESIGN - BRIDGE/STRUCTURE DESIGN
 CIVIL/SITE DESIGN - GIS/GPS - CONSTRUCTION OBSERVATION

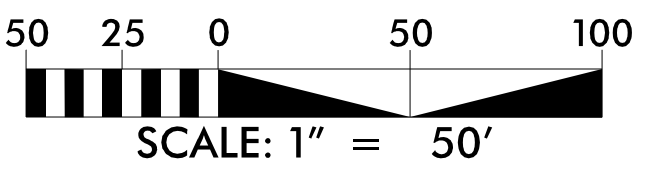

APPROVED: *Edw. H. May*
 DATE: 4/19/2022

**DOCUMENT NOT CONSIDERED FINAL
 UNLESS ALL SIGNATURES COMPLETED**

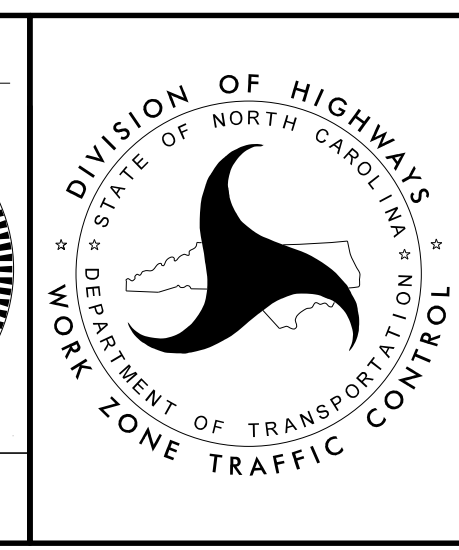

**PHASE II
 PLAN SHEET**

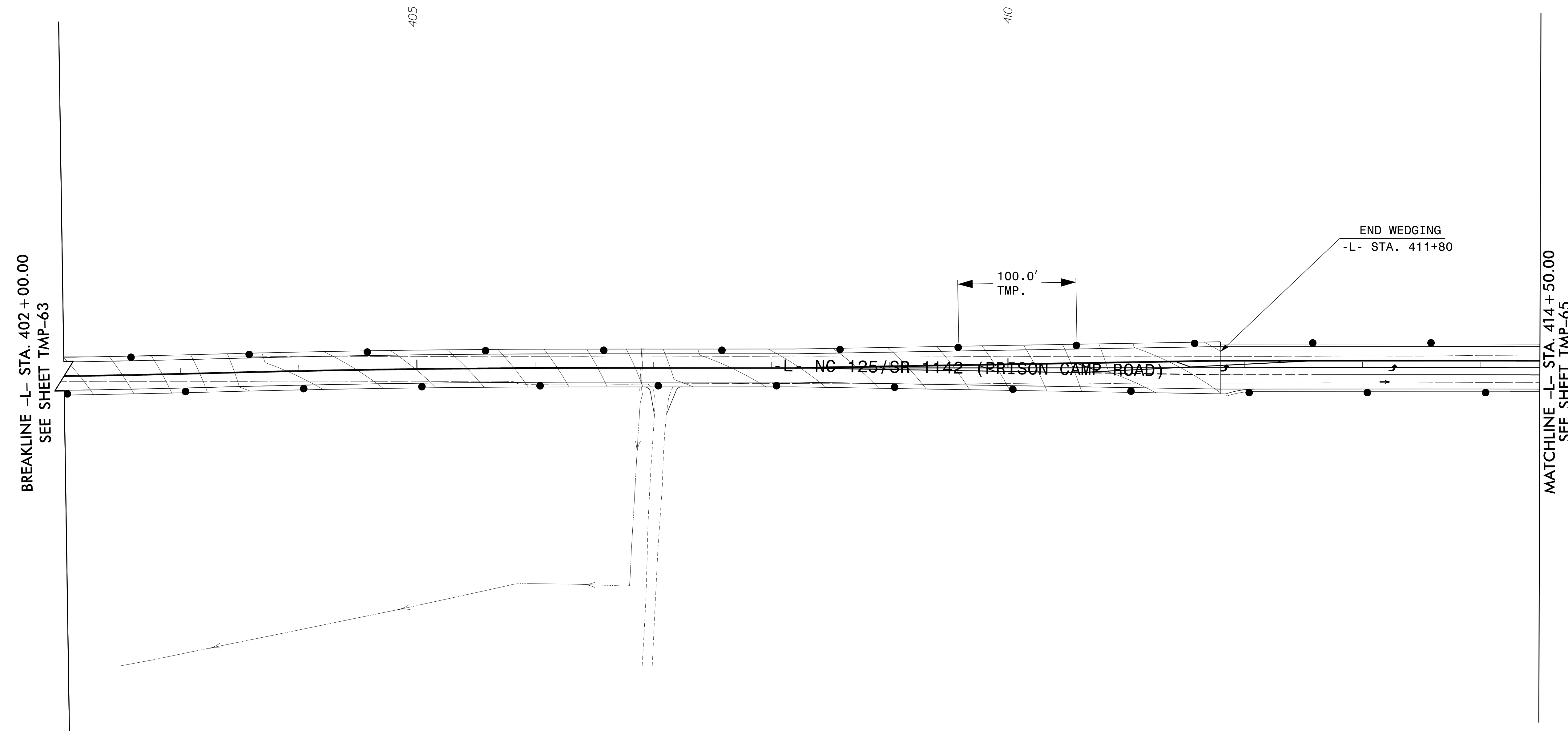

4/19/2022
 P:\2022\7175.01_R-4705-Final\Traffic\WZTC\TMP\Sheets\R-4705_TC_TMP_64_Phil.cadn
 User: philc

1223 Jones Franklin Rd.
 Raleigh, N.C. 27606
 License No. F-0377
 Bus: 919 851 8077
 Fax: 919 851 8107

TRANSPORTATION PLANNING/DESIGN - BRIDGE/STRUCTURE DESIGN
 CIVIL/SITE DESIGN - GIS/GPS - CONSTRUCTION OBSERVATION

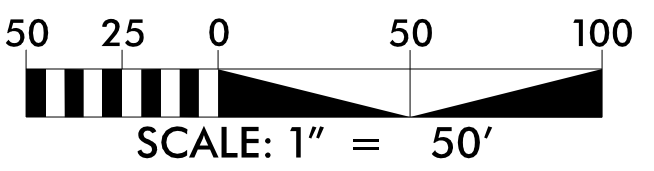

NOTES:

- CONTRACTOR SHALL INSTALL PAVEMENT MARKINGS PER THE FINAL PAVEMENT MARKING PLANS AND UTILIZE TEMPORARY PAINT.

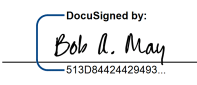
APPROVED: 
 DATE: 4/19/2022



DOCUMENT NOT CONSIDERED FINAL UNLESS ALL SIGNATURES COMPLETED

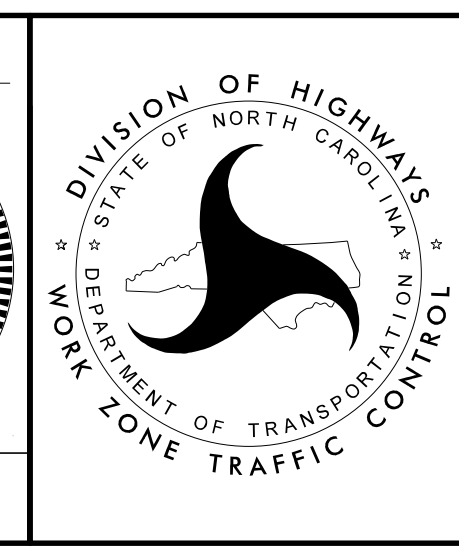

**PHASE II
 PLAN SHEET**

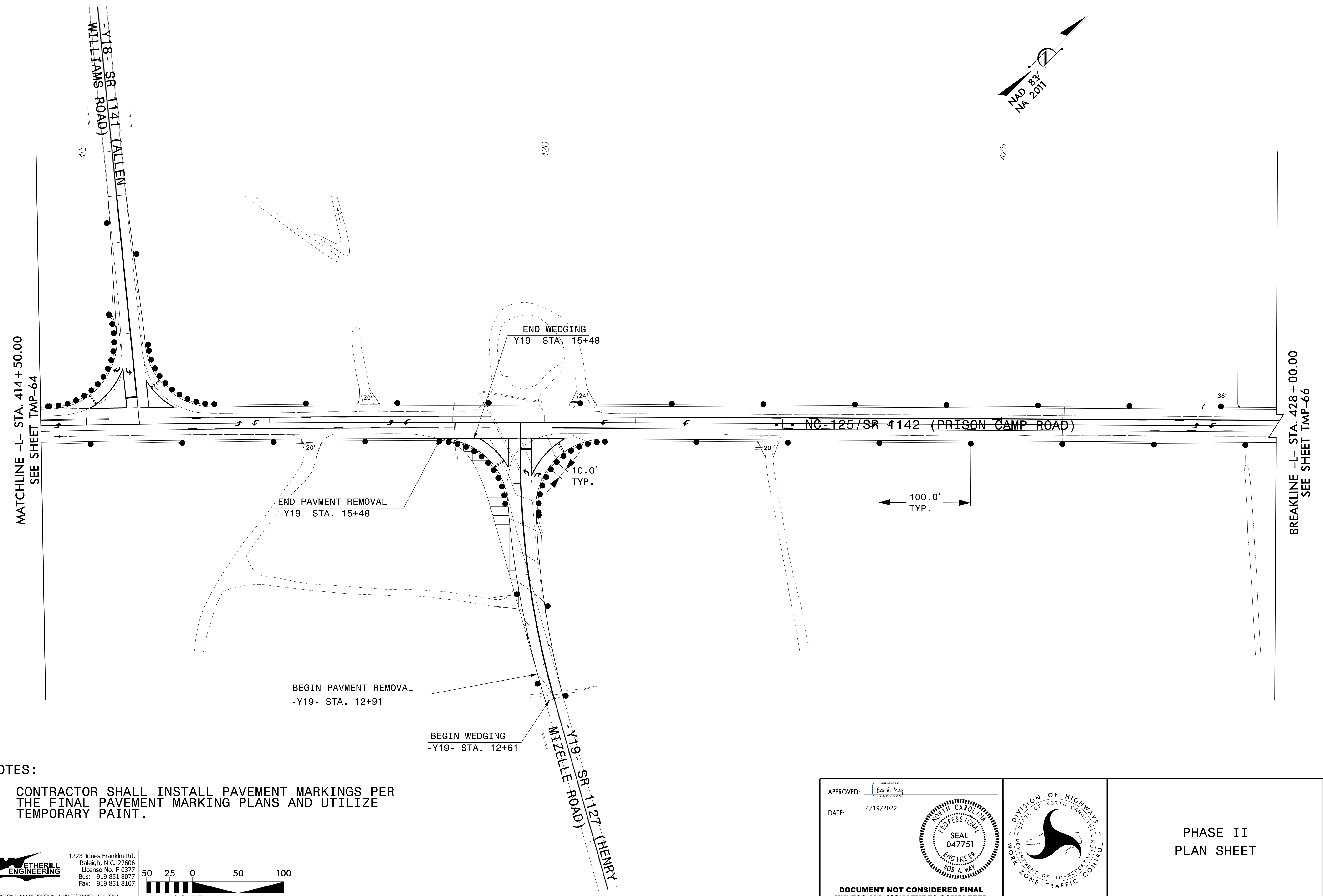
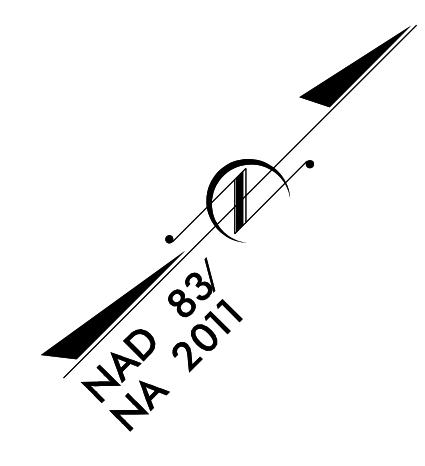

NOTES:

- CONTRACTOR SHALL INSTALL PAVEMENT MARKINGS PER THE FINAL PAVEMENT MARKING PLANS AND UTILIZE TEMPORARY PAINT.

4/19/2022
 P:\2022\175.01-R-4705-Final\Traffic\WZTC\TMP\Sheets\R-4705-TC-TMP-65 PHIL.dgn
 User: philc

ETHERILL ENGINEERING

1223 Jones Franklin Rd.
 Raleigh, N.C. 27606
 License No. F-0377
 Bus: 919 851 8077
 Fax: 919 851 8107

TRANSPORTATION PLANNING/DESIGN - BRIDGE/STRUCTURE DESIGN
 CIVIL/SITE DESIGN - GIS/GPS - CONSTRUCTION OBSERVATION

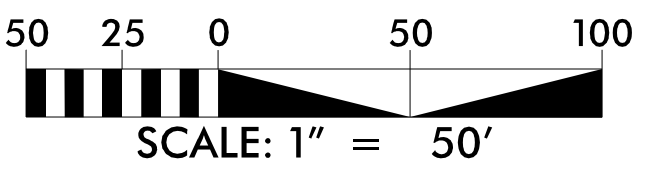

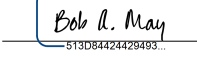
APPROVED: 

DATE: 4/19/2022

PROFESSIONAL SEAL
 NORTH CAROLINA
 047751
 ENGINEER
 BOB A. MAY

**DOCUMENT NOT CONSIDERED FINAL
 UNLESS ALL SIGNATURES COMPLETED**

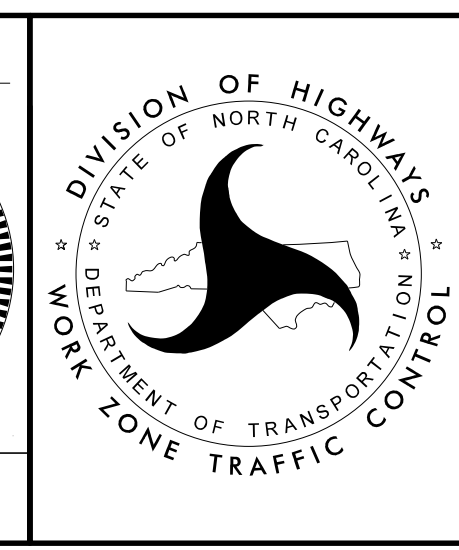

**PHASE II
 PLAN SHEET**

BREAKLINE -L- STA. 506+00.00
SEE SHEET TMP-65

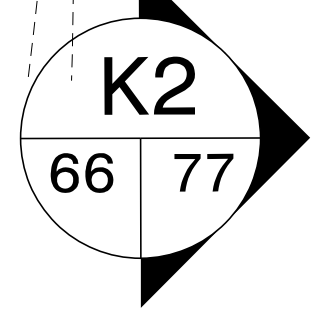
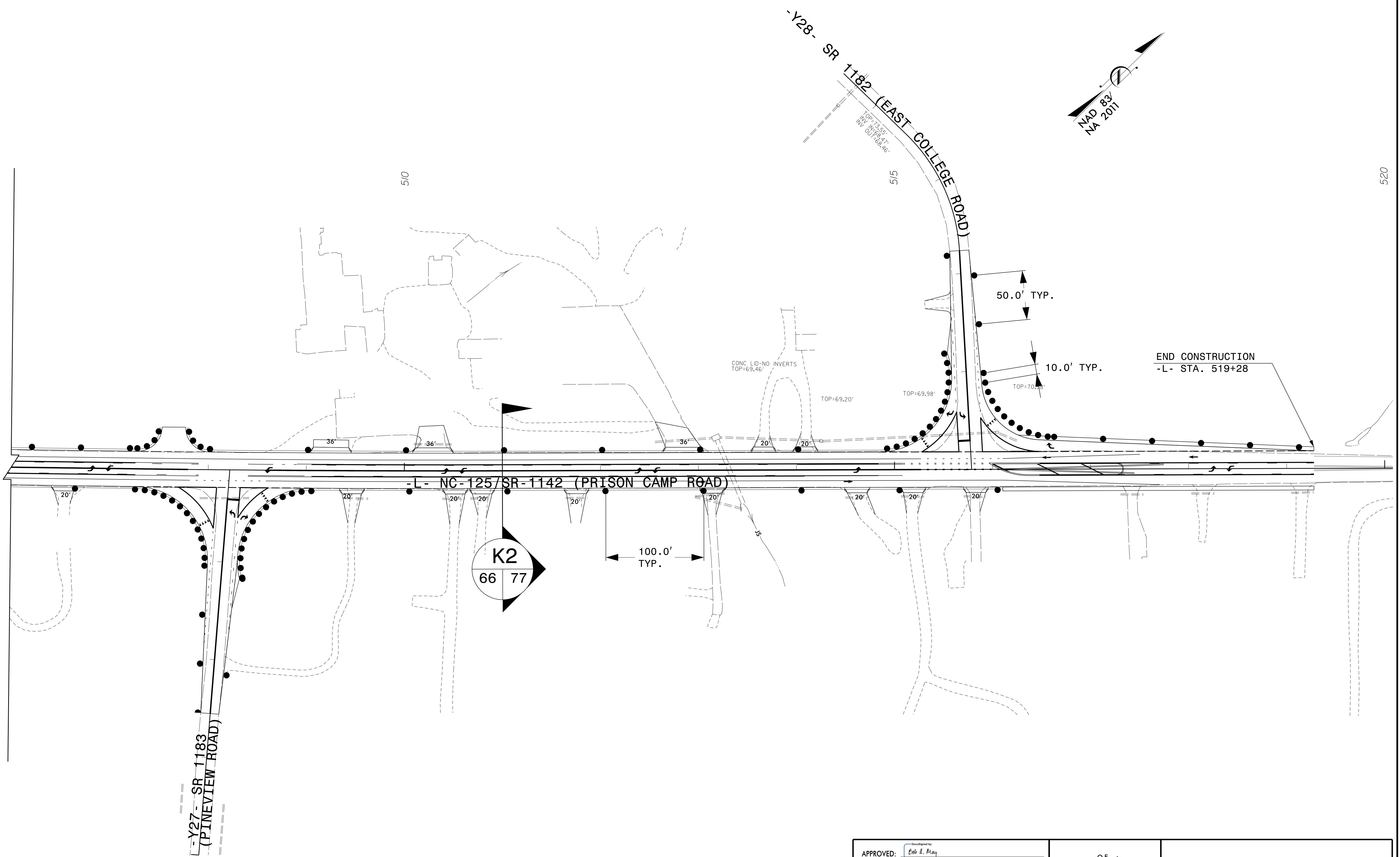

NOTES:

- CONTRACTOR SHALL INSTALL PAVEMENT MARKINGS PER THE FINAL PAVEMENT MARKING PLANS AND UTILIZE TEMPORARY PAINT.

ETHERILL ENGINEERING
1223 Jones Franklin Rd.
Raleigh, N.C. 27606
License No. F-0377
Bus: 919 851 8077
Fax: 919 851 8107

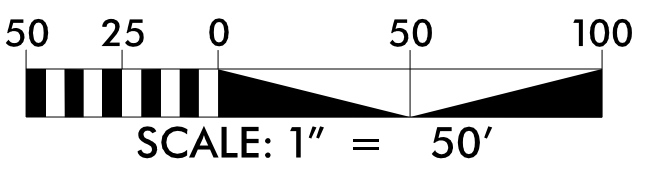

TRANSPORTATION PLANNING/DESIGN - BRIDGE/STRUCTURE DESIGN
CIVIL/SITE DESIGN - GIS/GPS - CONSTRUCTION OBSERVATION

APPROVED: *Edo H. May*
DATE: 4/19/2022

**DOCUMENT NOT CONSIDERED FINAL
UNLESS ALL SIGNATURES COMPLETED**

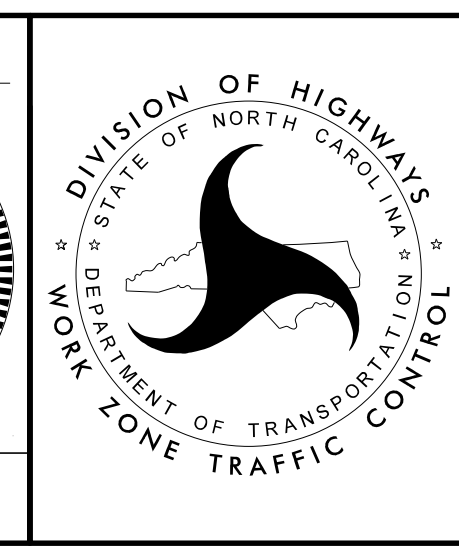

**PHASE II
PLAN SHEET**

4/19/2022
P:\2022\175.01-R-4705-Final\Traffic\WZTC\TMP\Sheets\R-4705_TC_TMP_66_Phil.dgn
User: phil

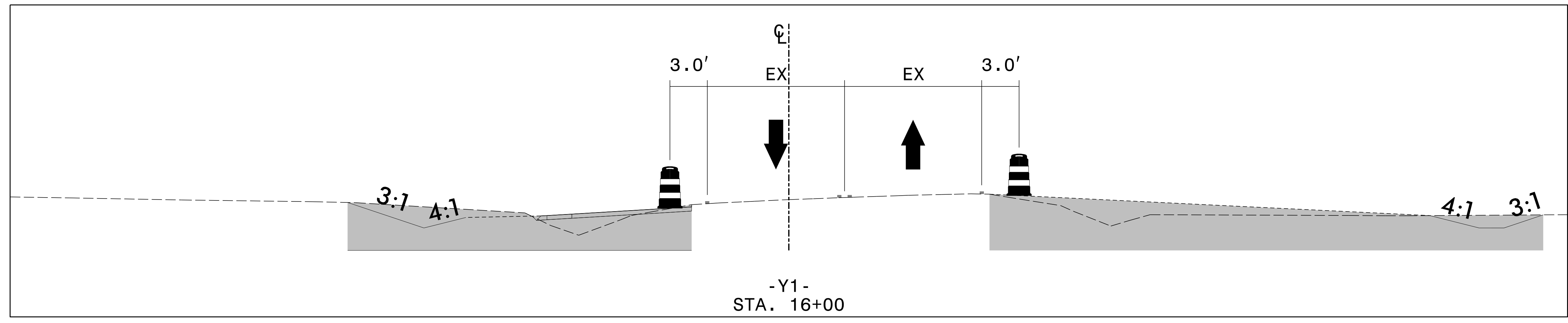

A1
04 | 67
STA. 16+00 -Y1-
CUT SECTION

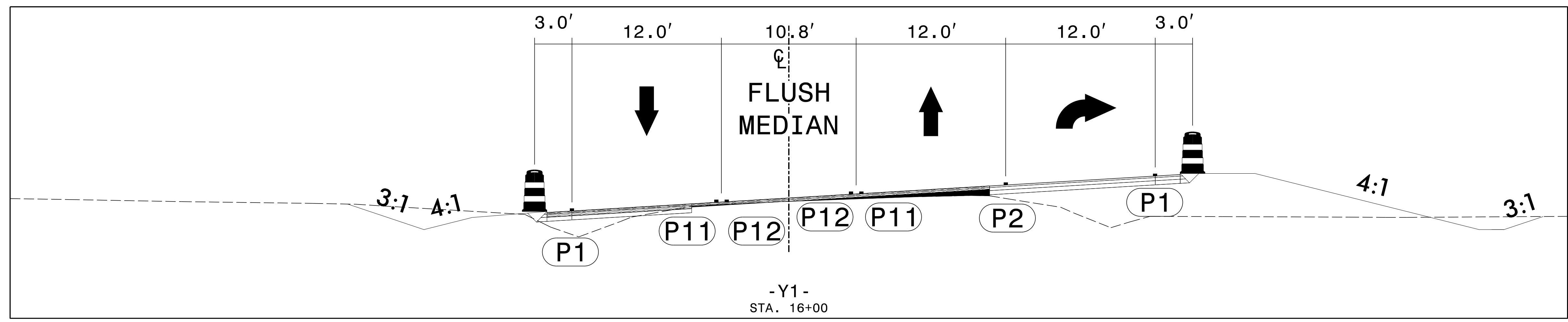

A2
44 | 67
STA. 16+00 -Y1-
CUT SECTION

3/14/2022 3:20:17 PM C:\Users\jfranklin\OneDrive\Documents\Traffic\WZTC\TMP\Sheets\R-4705-TC-TMP-67 TCS.dgn User: jfranklin

ETHERILL ENGINEERING
 1223 Jones Franklin Rd.
 Raleigh, N.C. 27606
 License No. F-0377
 Bus: 919 851 8077
 Fax: 919 851 8107

TRANSPORTATION PLANNING/DESIGN - BRIDGE/STRUCTURE DESIGN
 CIVIL/SITE DESIGN - GIS/GPS - CONSTRUCTION OBSERVATION

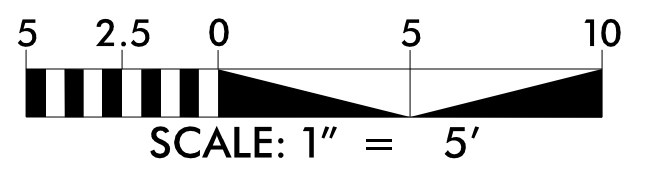

APPROVED: *Bob A. May*
 DATE: 4/7/2022

PROFESSIONAL SEAL
 NORTH CAROLINA
 047751
 ENGINEER
 BOB A. MAY

**DOCUMENT NOT CONSIDERED FINAL
 UNLESS ALL SIGNATURES COMPLETED**

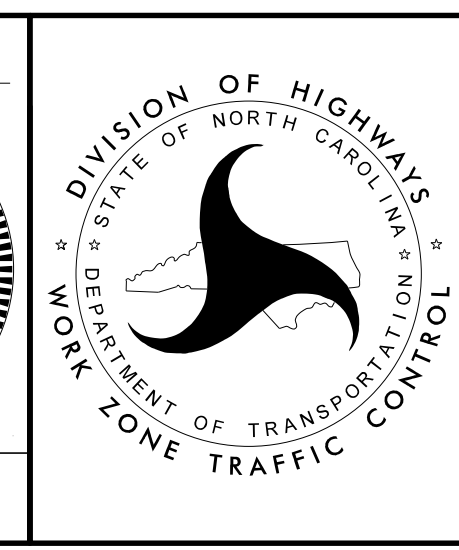

**TEMPORARY
 CROSS SECTIONS**

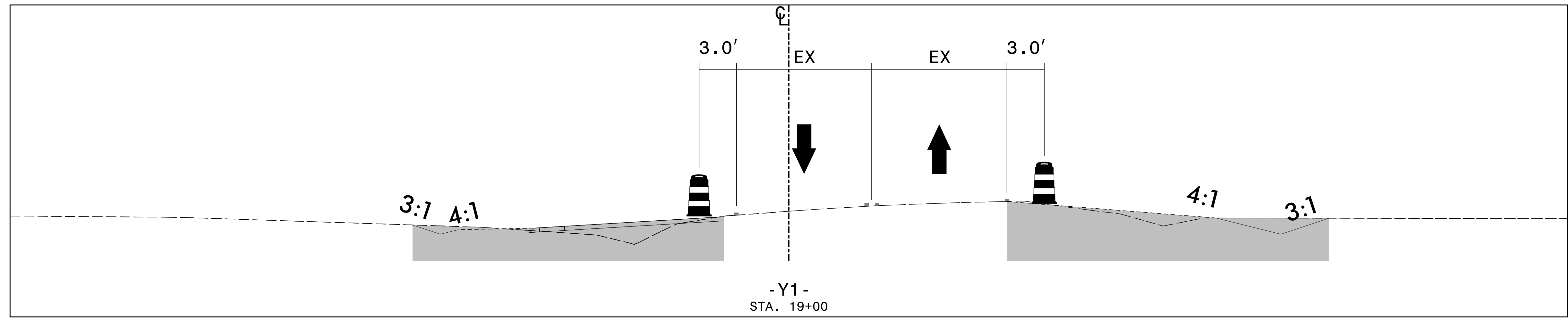

B1
04 | 68
STA. 19+00 -Y1-
CUT SECTION

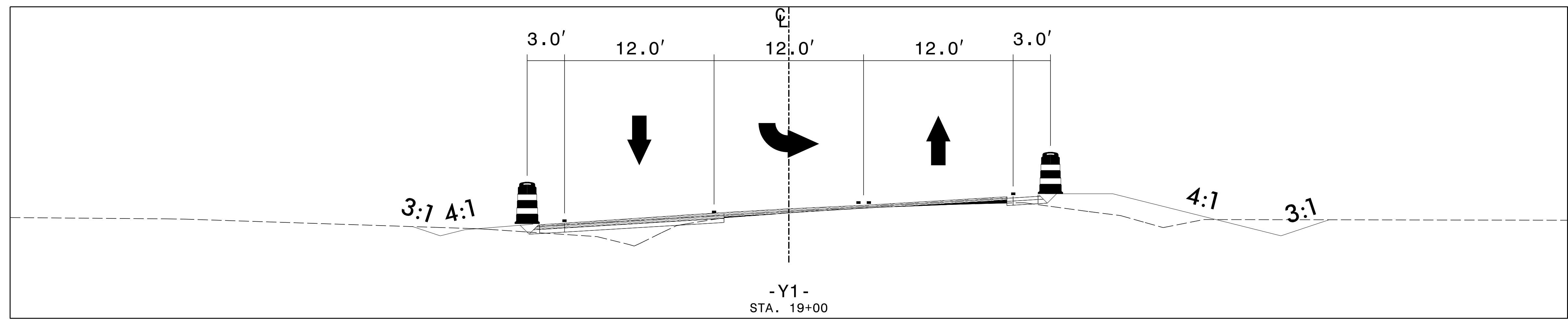

B2
44 | 68
STA. 19+00 -Y1-
CUT SECTION

3/14/2022
C:\2021\7175.01_R-4705-Final\Traffic\WZTC\TMP\Sheets\R-4705_TC_TMP_68_TCS.dgn
User: rathayes

ETHERILL ENGINEERING
1223 Jones Franklin Rd.
Raleigh, N.C. 27606
License No. F-0377
Bus: 919 851 8077
Fax: 919 851 8107

TRANSPORTATION PLANNING/DESIGN - BRIDGE/STRUCTURE DESIGN
CIVIL/SITE DESIGN - GIS/GPS - CONSTRUCTION OBSERVATION

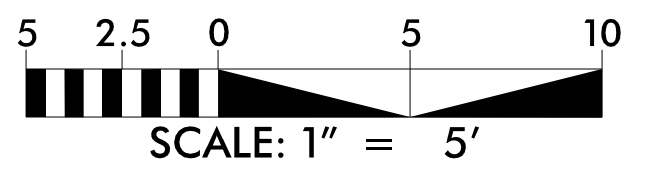

APPROVED: *Bob L. Ray*
DATE: 4/7/2022

SEAL
047751
ENGINEER
BOB A. MAY

**DOCUMENT NOT CONSIDERED FINAL
UNLESS ALL SIGNATURES COMPLETED**

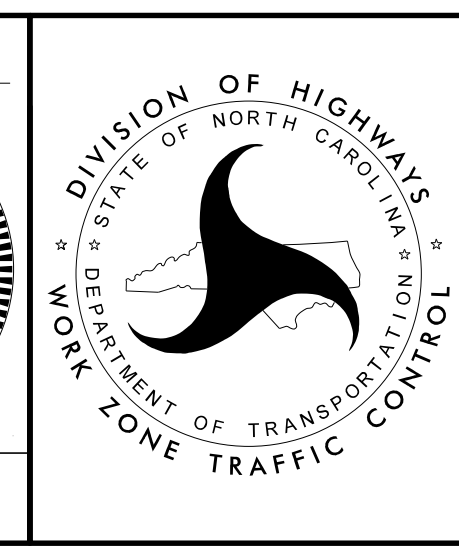

**TEMPORARY
CROSS SECTIONS**

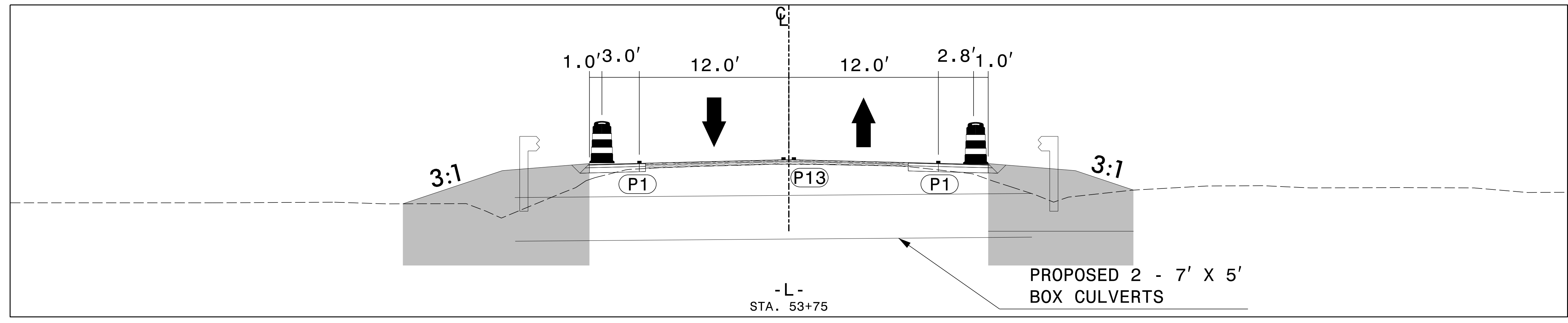

C1
 08 | 69



 STA. 53+75 -L-
 CUT SECTION

3/14/2022
 C:\2021\75.01_R-4705-Final\Traffic\WZTC\TMP\Sheets\R-4705_TC_TMP_69_TCS.dgn
 User: rathayes

KETHERILL ENGINEERING
 1223 Jones Franklin Rd.
 Raleigh, N.C. 27606
 License No. F-0377
 Bus: 919 851 8077
 Fax: 919 851 8107

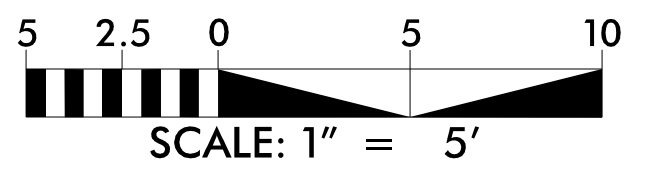
TRANSPORTATION PLANNING/DESIGN - BRIDGE/STRUCTURE DESIGN
 CIVIL/SITE DESIGN - GIS/GPS - CONSTRUCTION OBSERVATION

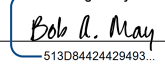
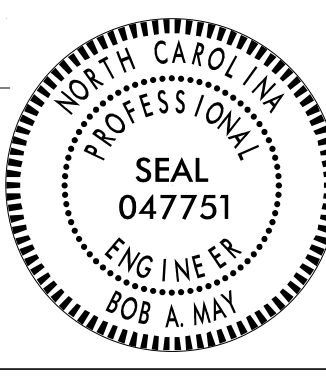

APPROVED:  DATE: 4/7/2022			TEMPORARY CROSS SECTIONS
DOCUMENT NOT CONSIDERED FINAL UNLESS ALL SIGNATURES COMPLETED			

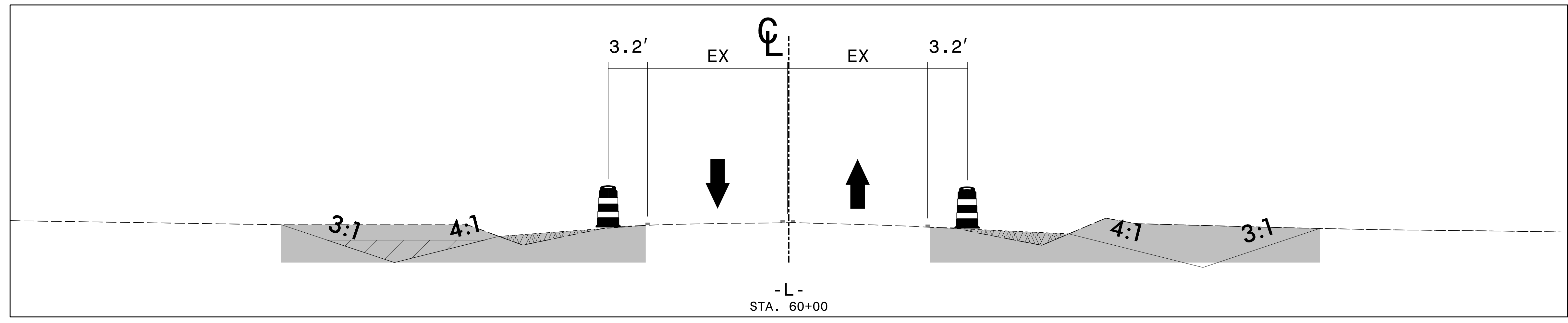

D1
08 | 70
STA. 60+00 -L-
CUT SECTION

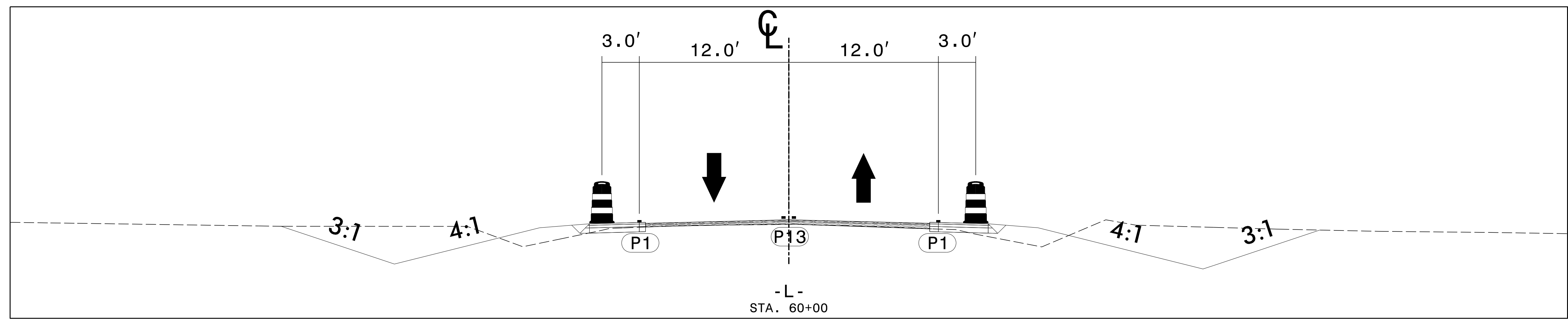

D2
48 | 70
STA. 60+00 -L-
CUT SECTION

3/14/2022
C:\2021\7175.01-R-4705-Final\Traffic\WZTC\TMP\Sheets\R-4705-TC-TMP-70 TCS.dgn
User: rathayes

ETHERILL ENGINEERING
1223 Jones Franklin Rd.
Raleigh, N.C. 27606
License No. F-0377
Bus: 919 851 8077
Fax: 919 851 8107

TRANSPORTATION PLANNING/DESIGN - BRIDGE/STRUCTURE DESIGN
CIVIL/SITE DESIGN - GIS/GPS - CONSTRUCTION OBSERVATION

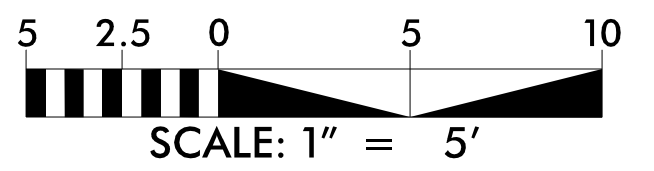

APPROVED: *Bob A. May*
DATE: 4/7/2022

PROFESSIONAL SEAL
047751
ENGINEER
BOB A. MAY

**DOCUMENT NOT CONSIDERED FINAL
UNLESS ALL SIGNATURES COMPLETED**

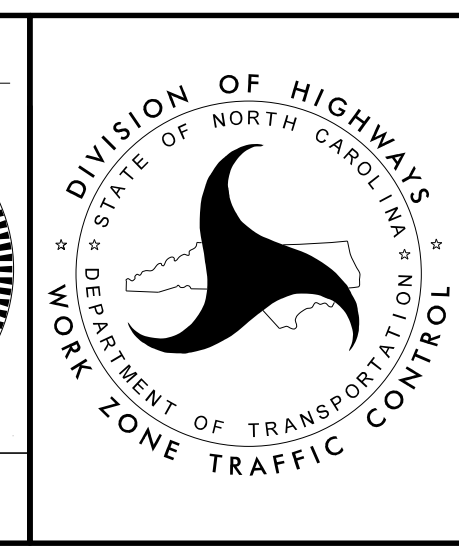

**TEMPORARY
CROSS SECTIONS**

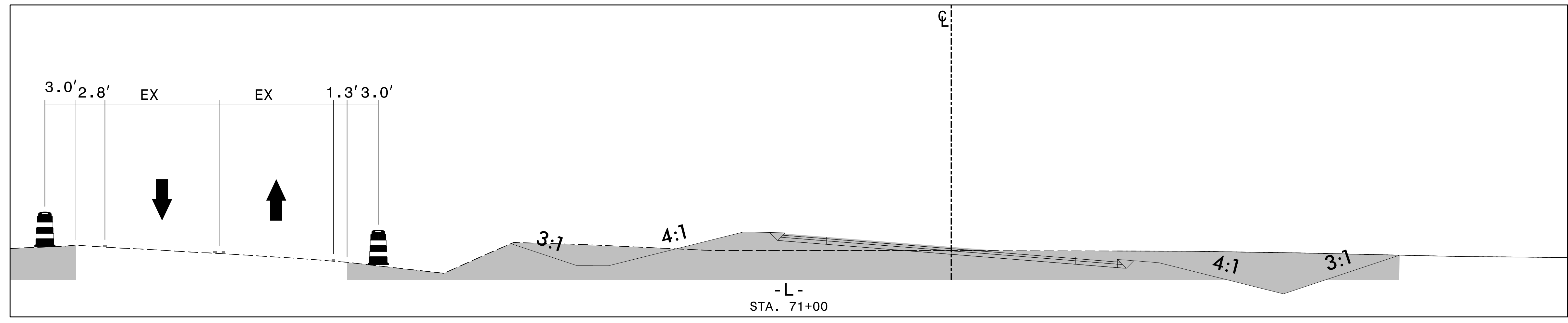

E1
09 | 71
STA. 71+00 -L-
CUT SECTION

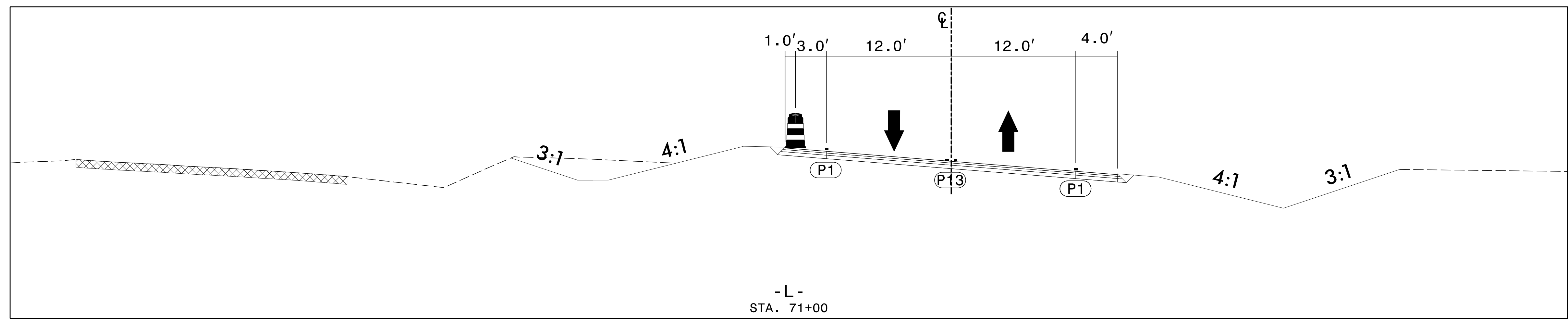

E2
49 | 71
STA. 71+00 -L-
CUT SECTION

3/4/2022
C:\2021\715.01_R-4705-Final\Traffic\WZTC\TMP\Sheets\R-4705_TC_TMP_71_TCS.dgn
User: jh101

ETHERILL ENGINEERING
1223 Jones Franklin Rd.
Raleigh, N.C. 27606
License No. F-0377
Bus: 919 851 8077
Fax: 919 851 8107

TRANSPORTATION PLANNING/DESIGN - BRIDGE/STRUCTURE DESIGN
CIVIL/SITE DESIGN - GIS/GPS - CONSTRUCTION OBSERVATION

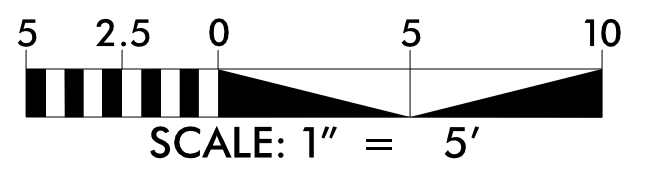

APPROVED: *Bob A. May*
DATE: 4/7/2022

PROFESSIONAL SEAL
047751
ENG. IN EN.
BOB A. MAY

**DOCUMENT NOT CONSIDERED FINAL
UNLESS ALL SIGNATURES COMPLETED**

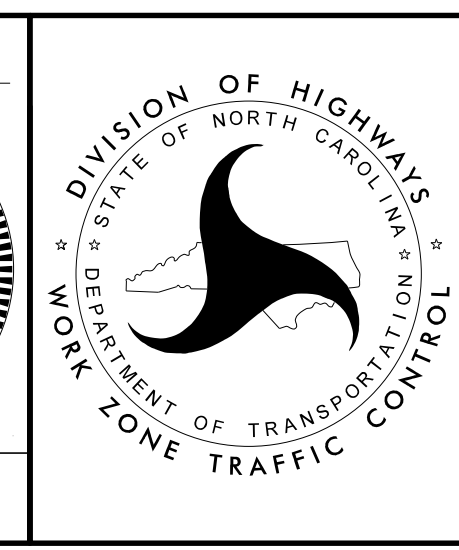

**TEMPORARY
CROSS SECTIONS**

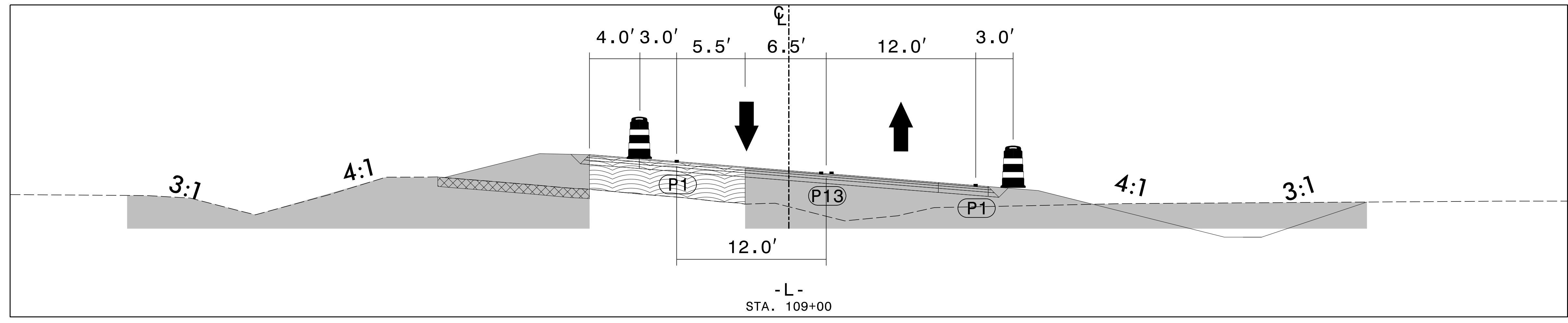

F1
12 | 72
STA. 109+00 -L-
CUT SECTION

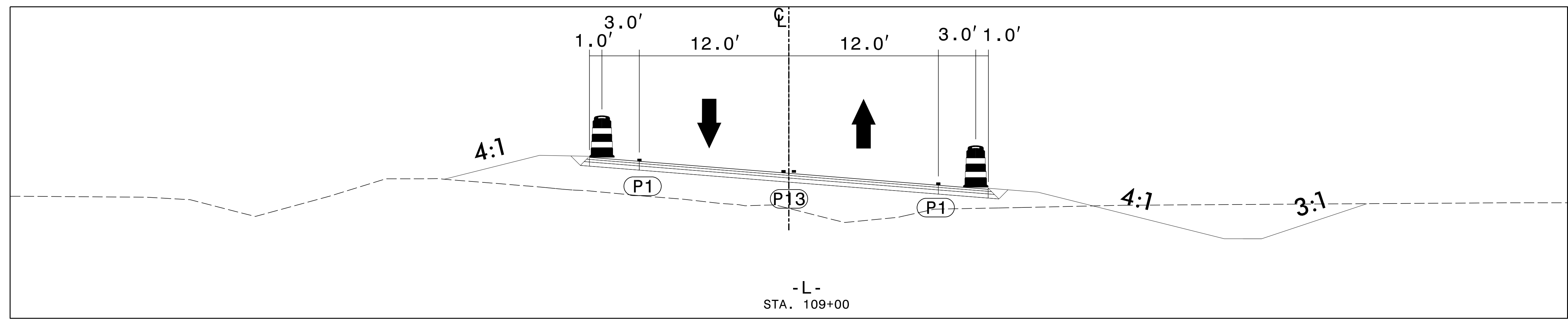

F2
52 | 72
STA. 109+00 -L-
CUT SECTION

3/14/2022
C:\2021\7175.01_R-4705-Final\Traffic\WZTC\TMP\Sheets\R-4705_TC_TMP_72_TCS.dgn
User: rathayes

ETHERILL ENGINEERING
1223 Jones Franklin Rd.
Raleigh, N.C. 27606
License No. F-0377
Bus: 919 851 8077
Fax: 919 851 8107

TRANSPORTATION PLANNING/DESIGN - BRIDGE/STRUCTURE DESIGN
CIVIL/SITE DESIGN - GIS/GPS - CONSTRUCTION OBSERVATION

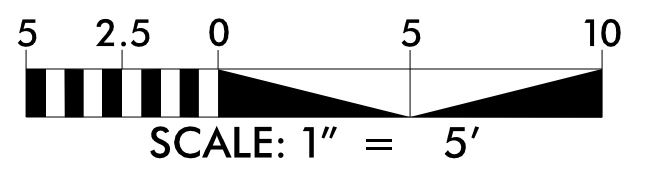

APPROVED: *Pete R. May*
DATE: 4/7/2022

DESIGNED BY: *Pete R. May*
51308420420693

SEAL
047751
ENGINEER
BOB A. MAY

**DOCUMENT NOT CONSIDERED FINAL
UNLESS ALL SIGNATURES COMPLETED**

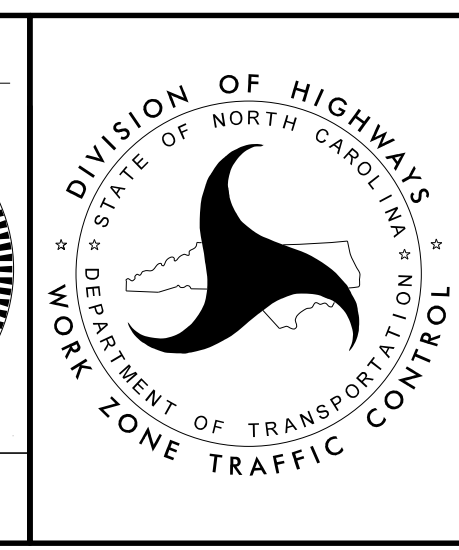

**TEMPORARY
CROSS SECTIONS**

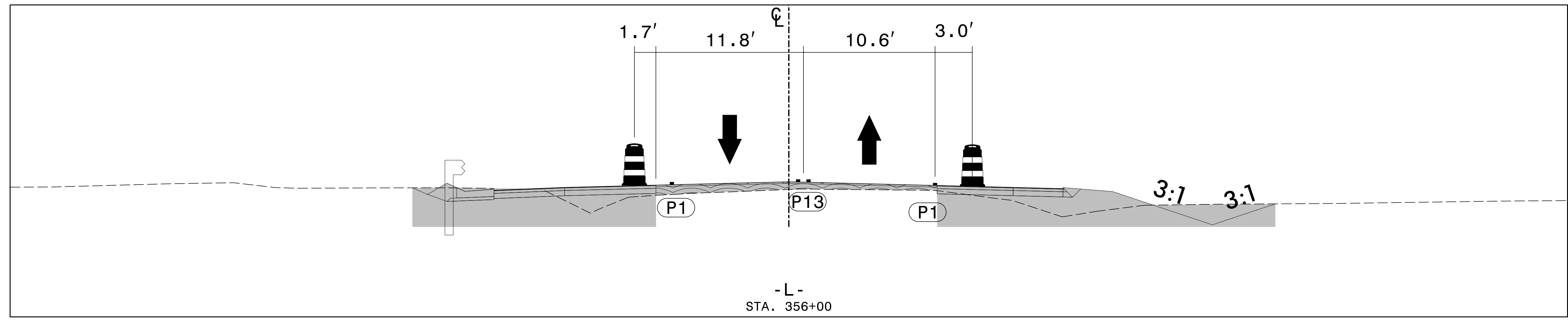

G1
31 | 73
STA. 356+00 -L-
CUT SECTION

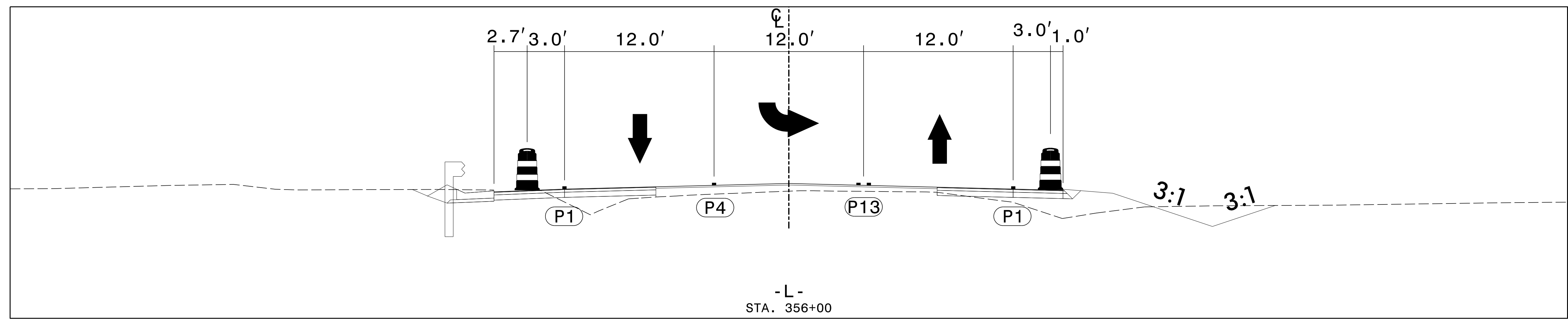

G2
61 | 73
STA. 356+00 -L-
CUT SECTION

3/14/2022
C:\2021\7175.01_R-4705-Final\Traffic\WZTC\TMP\Sheets\R-4705_TC_TMP_73_TCS.dgn
User: rathayes

ETHERILL ENGINEERING
1223 Jones Franklin Rd.
Raleigh, N.C. 27606
License No. F-0377
Bus: 919 851 8077
Fax: 919 851 8107

TRANSPORTATION PLANNING/DESIGN - BRIDGE/STRUCTURE DESIGN
CIVIL/SITE DESIGN - GIS/GPS - CONSTRUCTION OBSERVATION

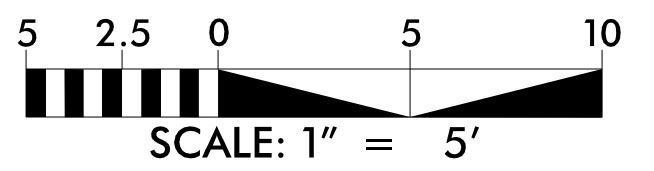

APPROVED: *Bob A. May*
DATE: 4/7/2022

PROFESSIONAL SEAL
047751
ENGINEER
BOB A. MAY

**DOCUMENT NOT CONSIDERED FINAL
UNLESS ALL SIGNATURES COMPLETED**

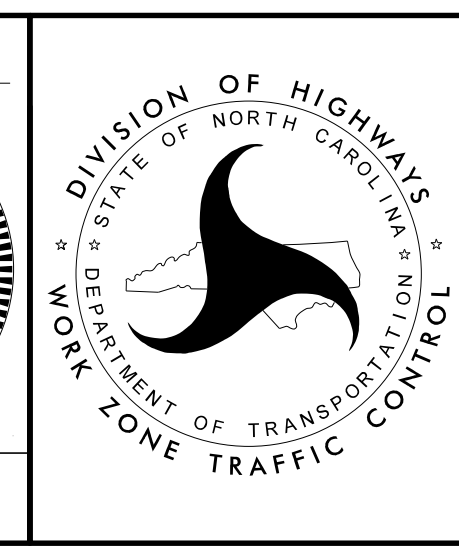

**TEMPORARY
CROSS SECTIONS**

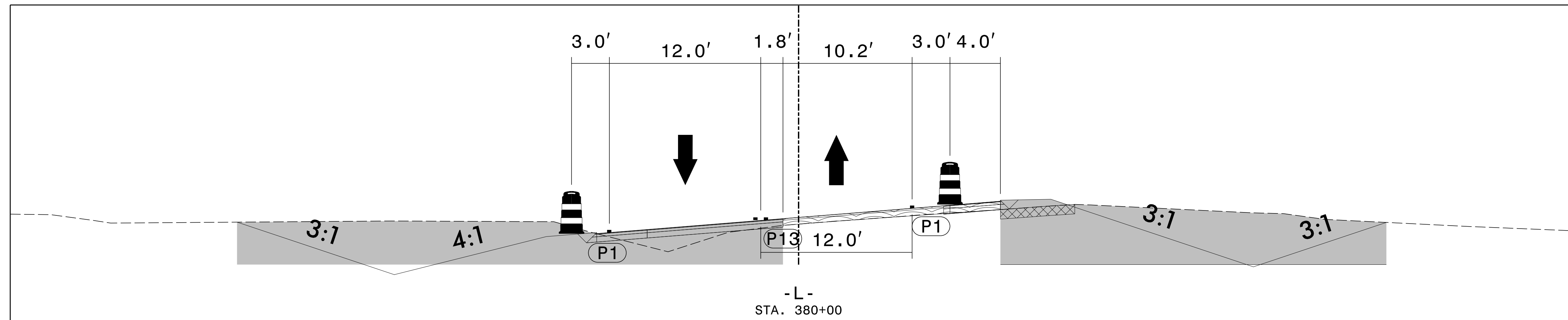

H1 STA. 380+00 -L-
33 | 74 CUT SECTION

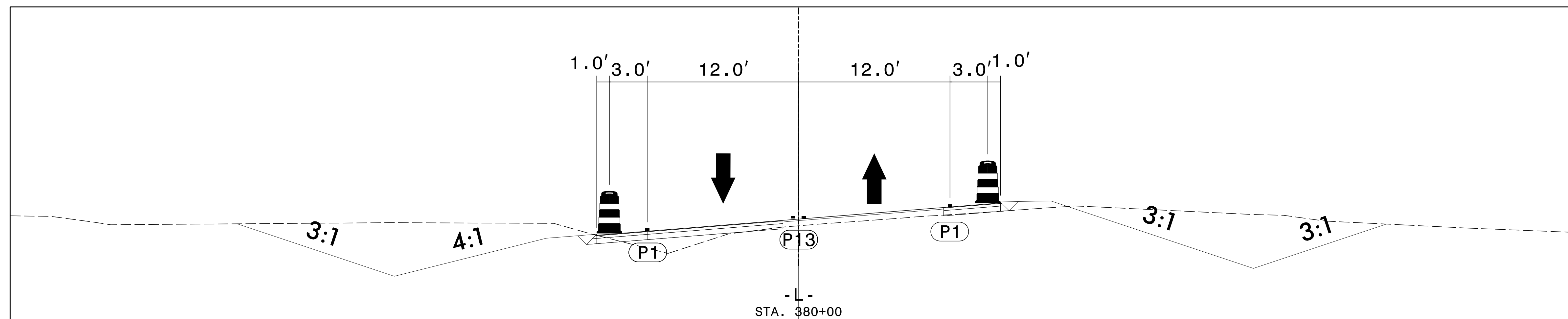

H2 STA. 380+00 -L-
63 | 74 CUT SECTION

3/14/2022
C:\2021\7175.01_R-4705-Final\Traffic\WZTC\TMP\Sheets\R-4705_TC_TMP_74_TCS.dgn
User: rathayes

ETHERILL ENGINEERING
1223 Jones Franklin Rd.
Raleigh, N.C. 27606
License No. F-0377
Bus: 919 851 8077
Fax: 919 851 8107
TRANSPORTATION PLANNING/DESIGN - BRIDGE/STRUCTURE DESIGN
CIVIL/SITE DESIGN - GIS/GPS - CONSTRUCTION OBSERVATION

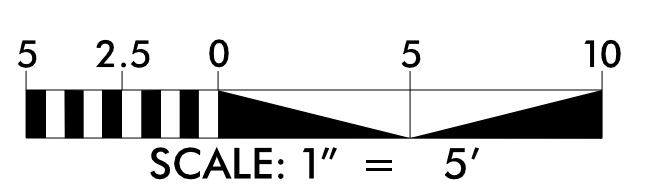

APPROVED: *Bob A. May*
DATE: 4/7/2022

Seal: NORTH CAROLINA PROFESSIONAL ENGINEER SEAL 047751 BOB A. MAY

DOCUMENT NOT CONSIDERED FINAL UNLESS ALL SIGNATURES COMPLETED

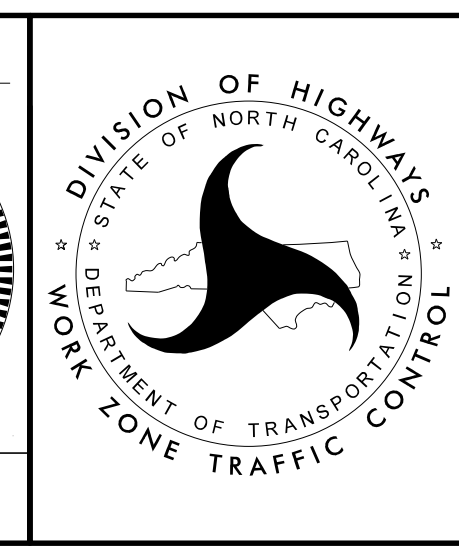

TEMPORARY CROSS SECTIONS

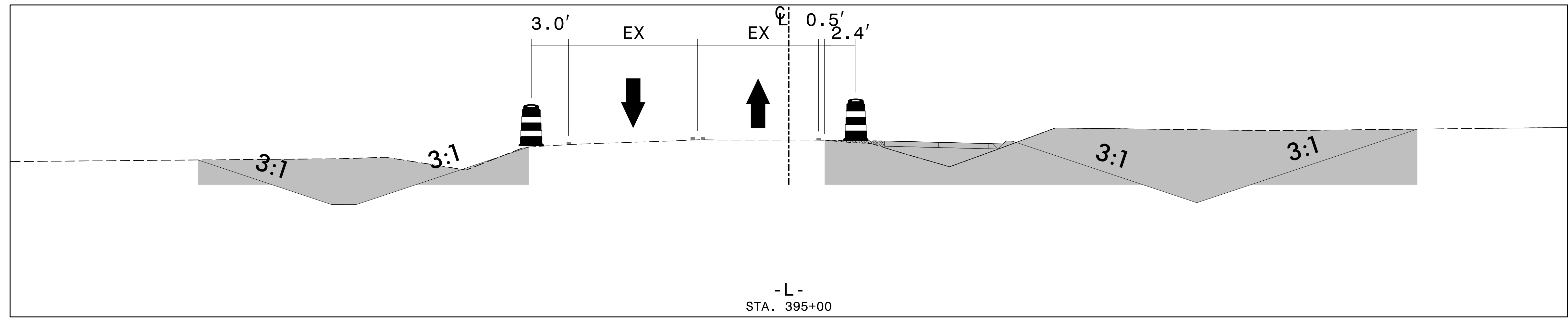

I 1
 34 | 75

 STA. 395+00 -L-
 CUT SECTION

3/14/2022
 D:\2021\75.01_R-4705-Final\Traffic\WZTC\TMP\Sheets\R-4705_TC_TMP_75_TCS.dgn
 User: rathayes

WETHERILL ENGINEERING
 1223 Jones Franklin Rd.
 Raleigh, N.C. 27606
 License No. F-0377
 Bus: 919 851 8077
 Fax: 919 851 8107

TRANSPORTATION PLANNING/DESIGN - BRIDGE/STRUCTURE DESIGN
 CIVIL/SITE DESIGN - GIS/GPS - CONSTRUCTION OBSERVATION

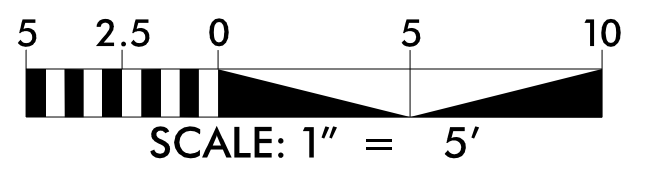

APPROVED: DATE: 4/7/2022			<h2 style="margin: 0;">TEMPORARY CROSS SECTIONS</h2>
DOCUMENT NOT CONSIDERED FINAL UNLESS ALL SIGNATURES COMPLETED			

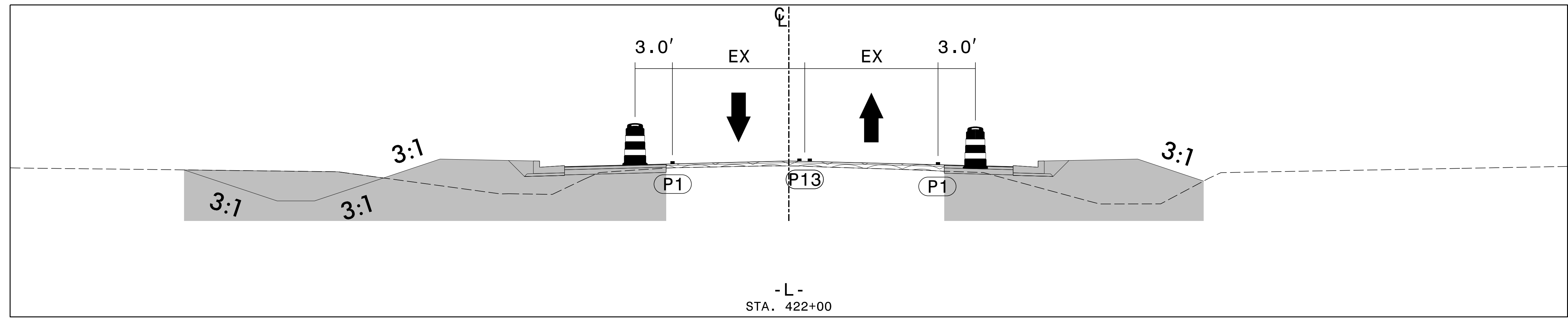

J1
36 76 STA. 422+00 -L-
CUT SECTION

3/14/2022
C:\2022\75.01_R-4705-Final\Traffic\WZTC\TMP\Sheets\R-4705_TC_TMP_76_TCS.dgn
User: jh1414

ETHERILL ENGINEERING
1223 Jones Franklin Rd.
Raleigh, N.C. 27606
License No. F-0377
Bus: 919 851 8077
Fax: 919 851 8107

TRANSPORTATION PLANNING/DESIGN - BRIDGE/STRUCTURE DESIGN
CIVIL/SITE DESIGN - GIS/GPS - CONSTRUCTION OBSERVATION

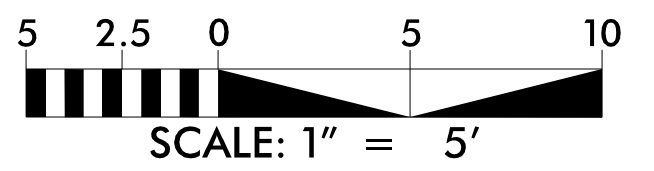

APPROVED: *Bob A. May*
DATE: 4/7/2022

SEAL
047751
ENGINEER
BOB A. MAY

**DOCUMENT NOT CONSIDERED FINAL
UNLESS ALL SIGNATURES COMPLETED**

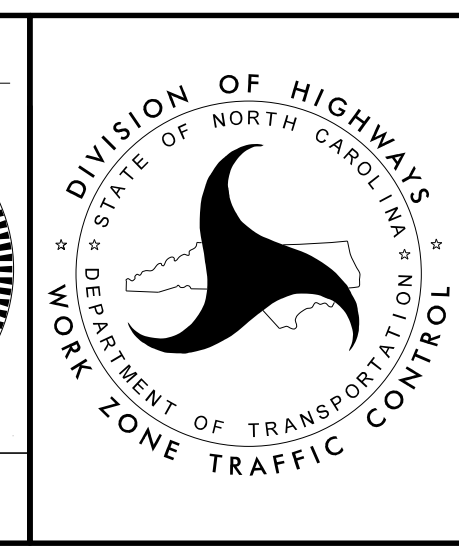

**TEMPORARY
CROSS SECTIONS**

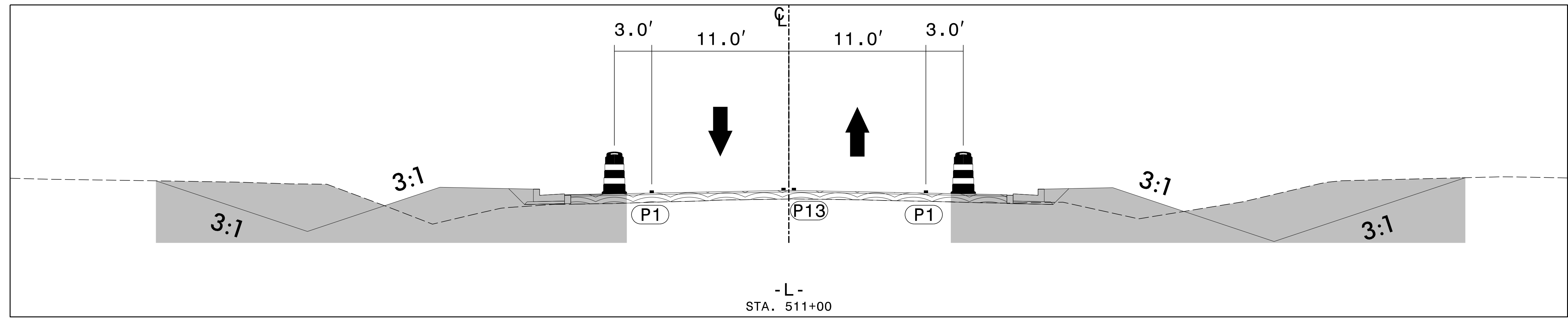

K1
43 | 77
STA. 511+00 -L-
CUT SECTION

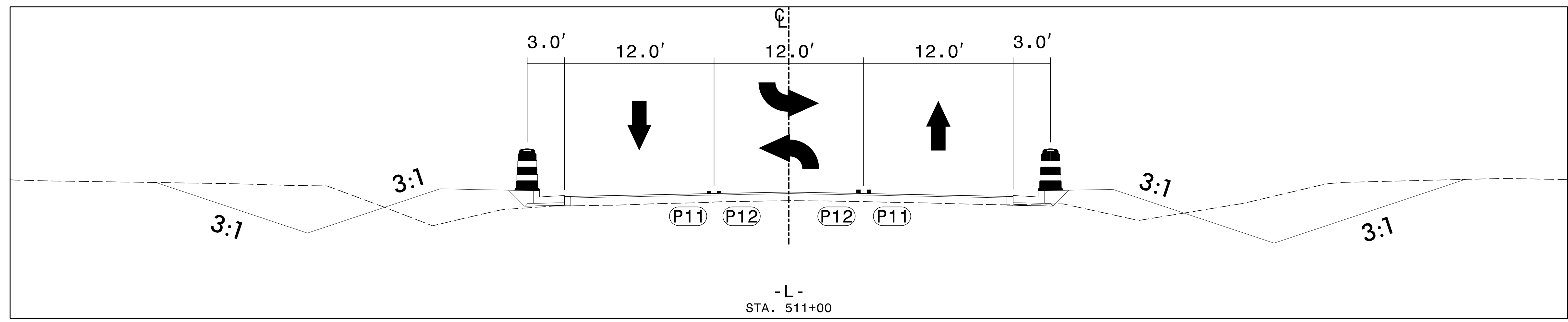

K2
66 | 77
STA. 511+00 -L-
CUT SECTION

3/14/2022
C:\2021\7175.01_R-4705-Final\Traffic\WZTC\TMP\Sheets\R-4705_TC_TMP_77_TCS.dgn
User: r4705

ETHERILL ENGINEERING
1223 Jones Franklin Rd.
Raleigh, N.C. 27606
License No. F-0377
Bus: 919 851 8077
Fax: 919 851 8107

TRANSPORTATION PLANNING/DESIGN - BRIDGE/STRUCTURE DESIGN
CIVIL/SITE DESIGN - GIS/GPS - CONSTRUCTION OBSERVATION

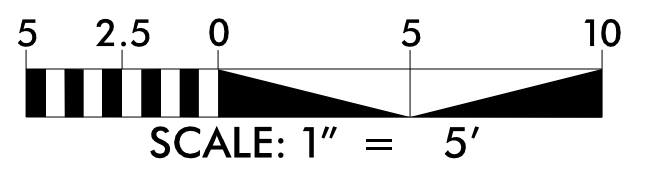

APPROVED: *Bob A. May*
DATE: 4/7/2022

SEAL
047751
ENGINEER
BOB A. MAY

**DOCUMENT NOT CONSIDERED FINAL
UNLESS ALL SIGNATURES COMPLETED**

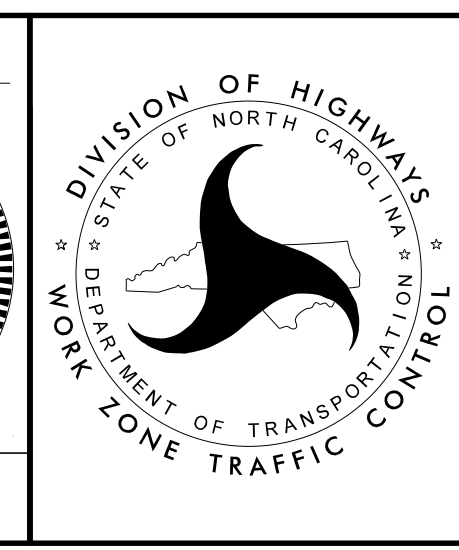

**TEMPORARY
CROSS SECTIONS**