

8/17/99

PROJECT REFERENCE NO.	SHEET NO.
R-4705	UC-40B
DESIGNED BY: SLK	3/25/2012
DRAWN BY: SLK	
CHECKED BY: AMM	
APPROVED BY: AMM	
REVISED:	
NORTH CAROLINA DEPARTMENT OF TRANSPORTATION UTILITIES ENGINEERING SEC. PHONE: (919) 707-6690 FAX: (919) 250-4151	
UTILITY CONSTRUCTION PLANS ONLY	

UTILITY CONSTRUCTION  
DOCUMENT NOT CONSIDERED FINAL UNLESS ALL SIGNATURES COMPLETED

**FINAL DESIGN**  
RELEASE FOR CONSTRUCTION

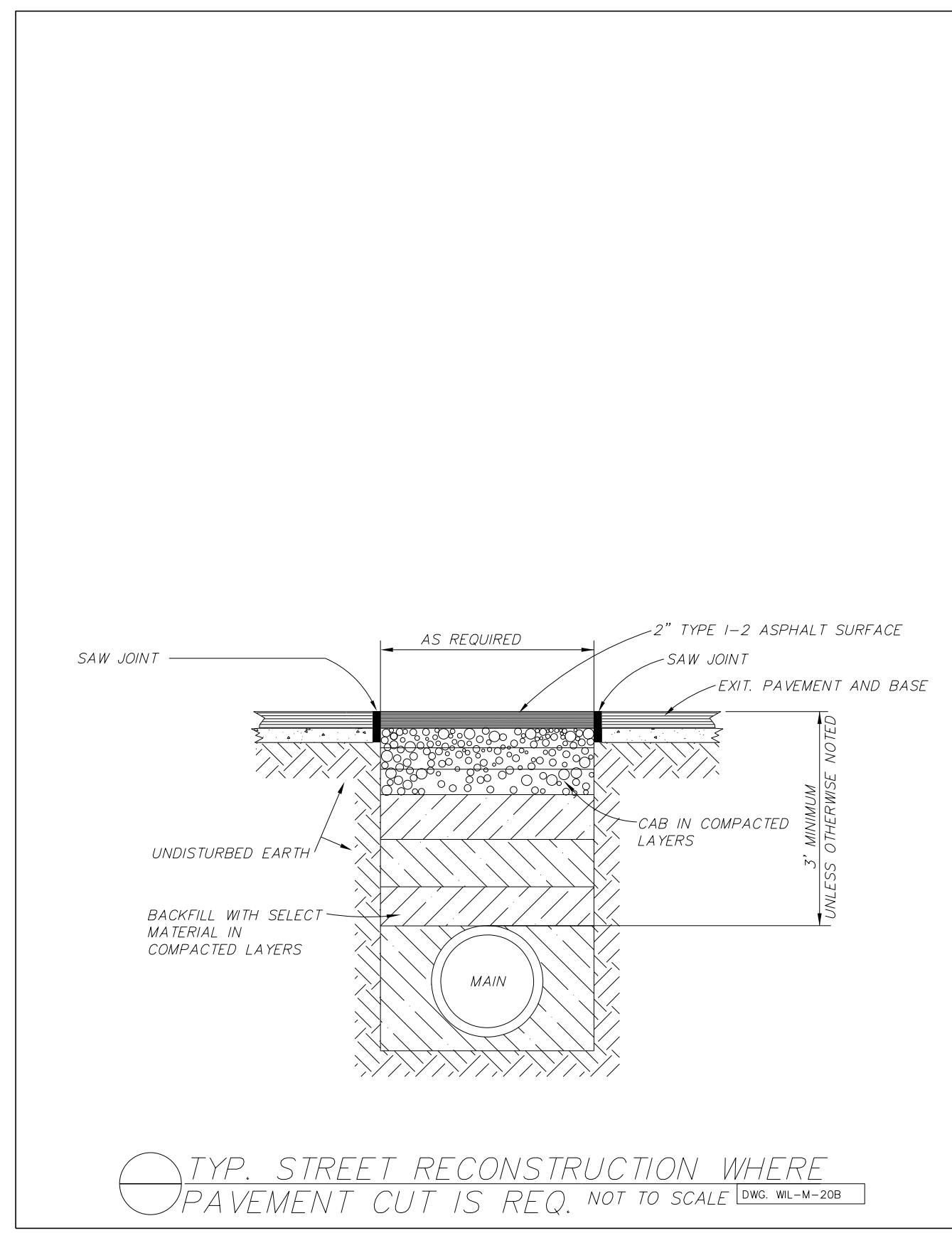
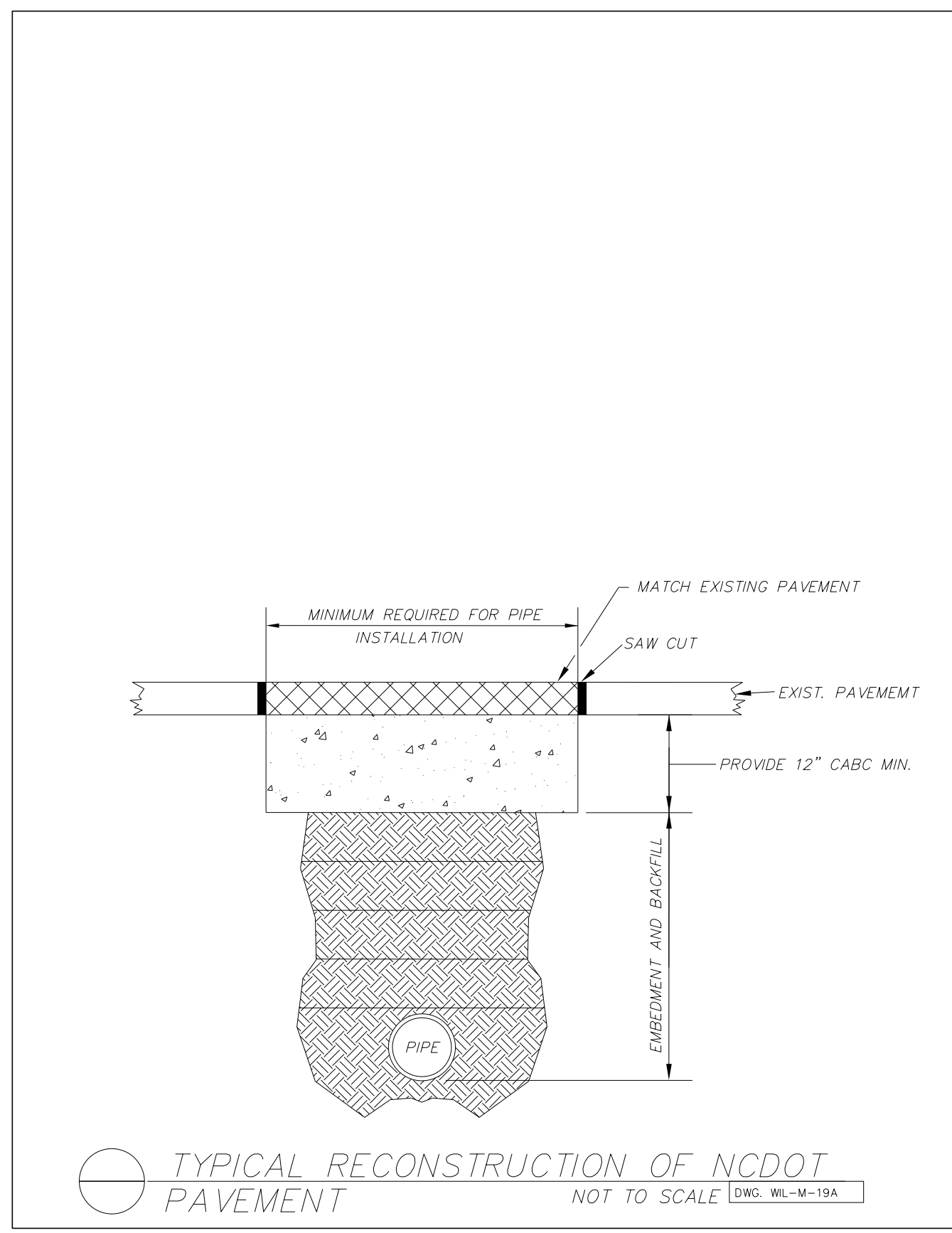
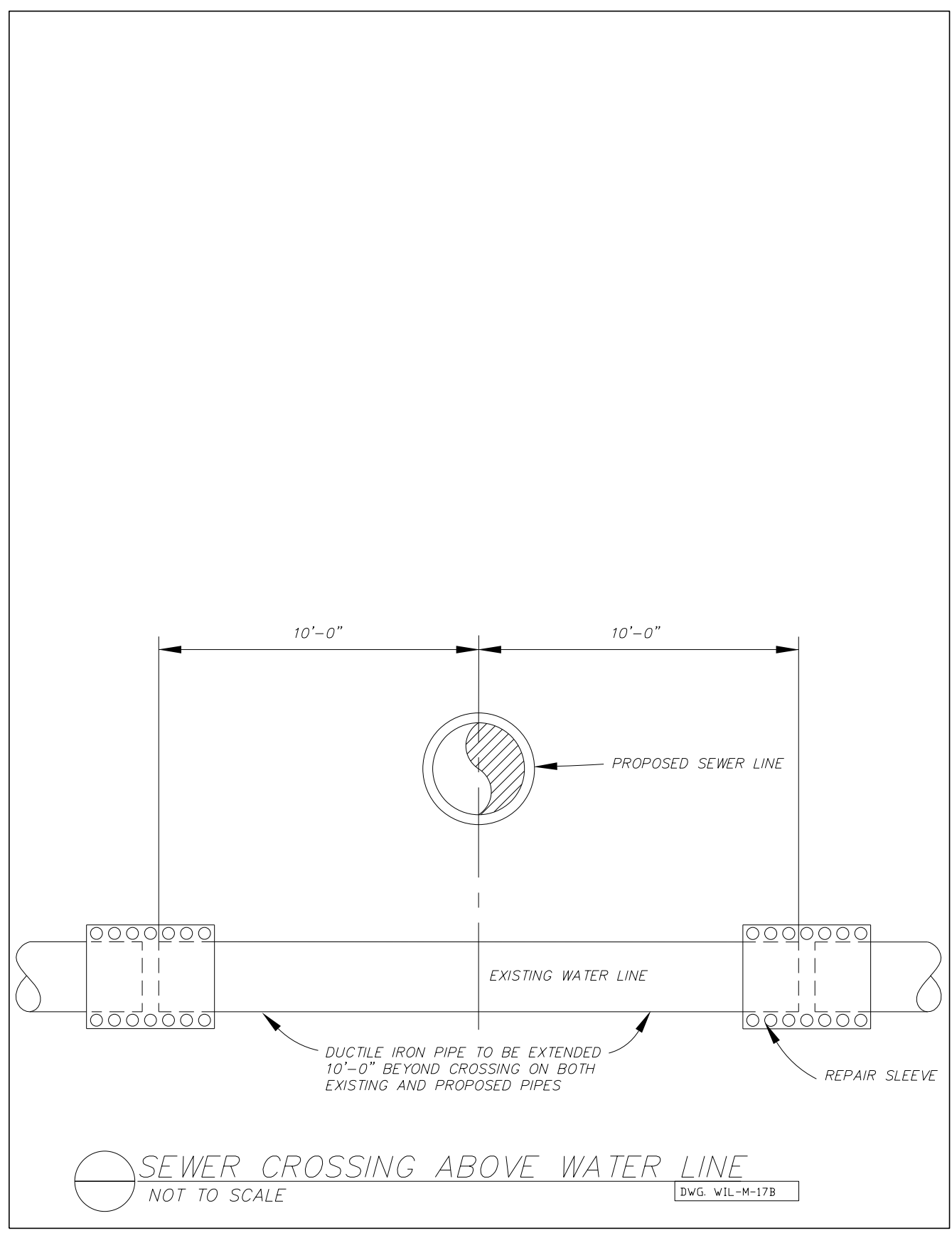
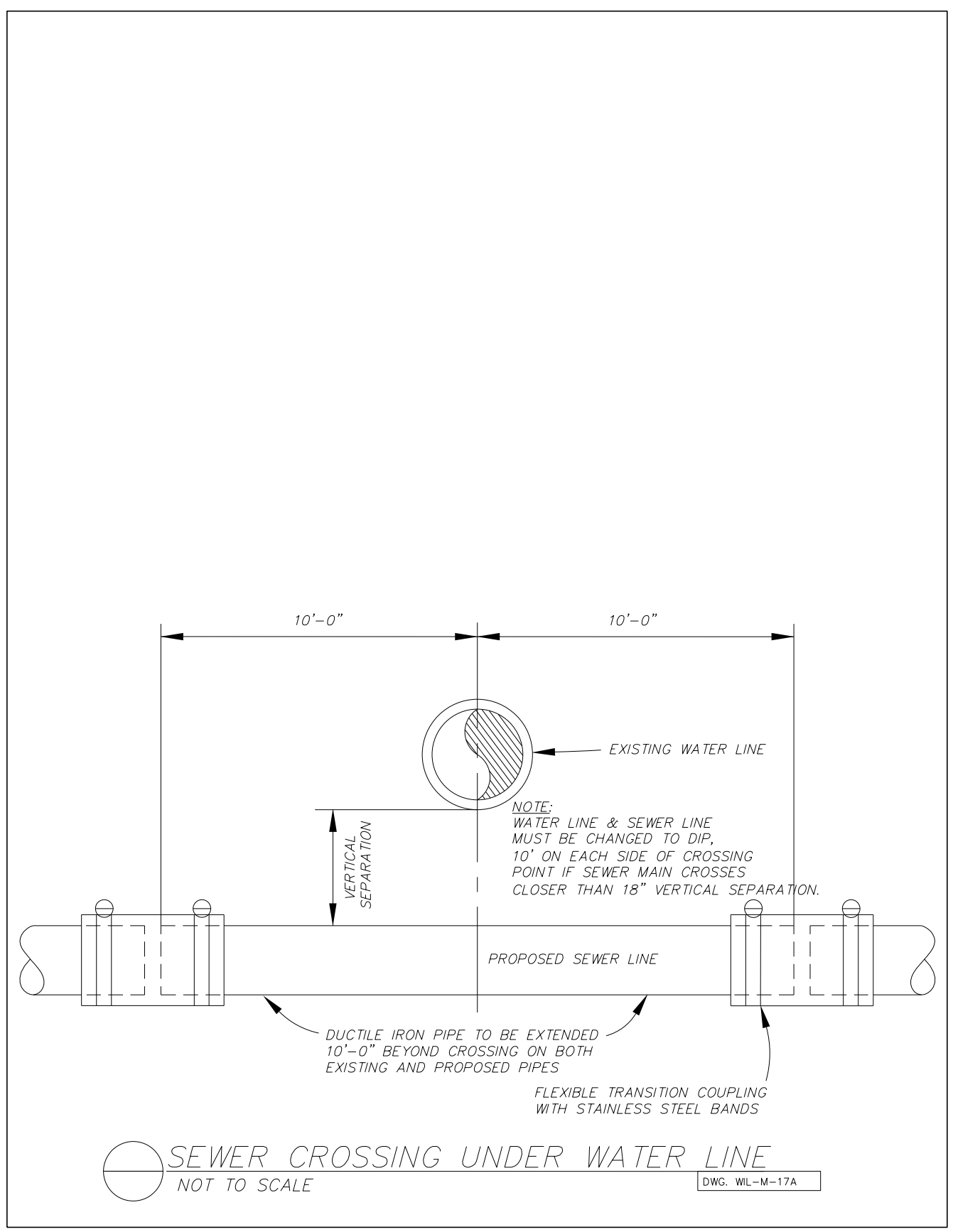
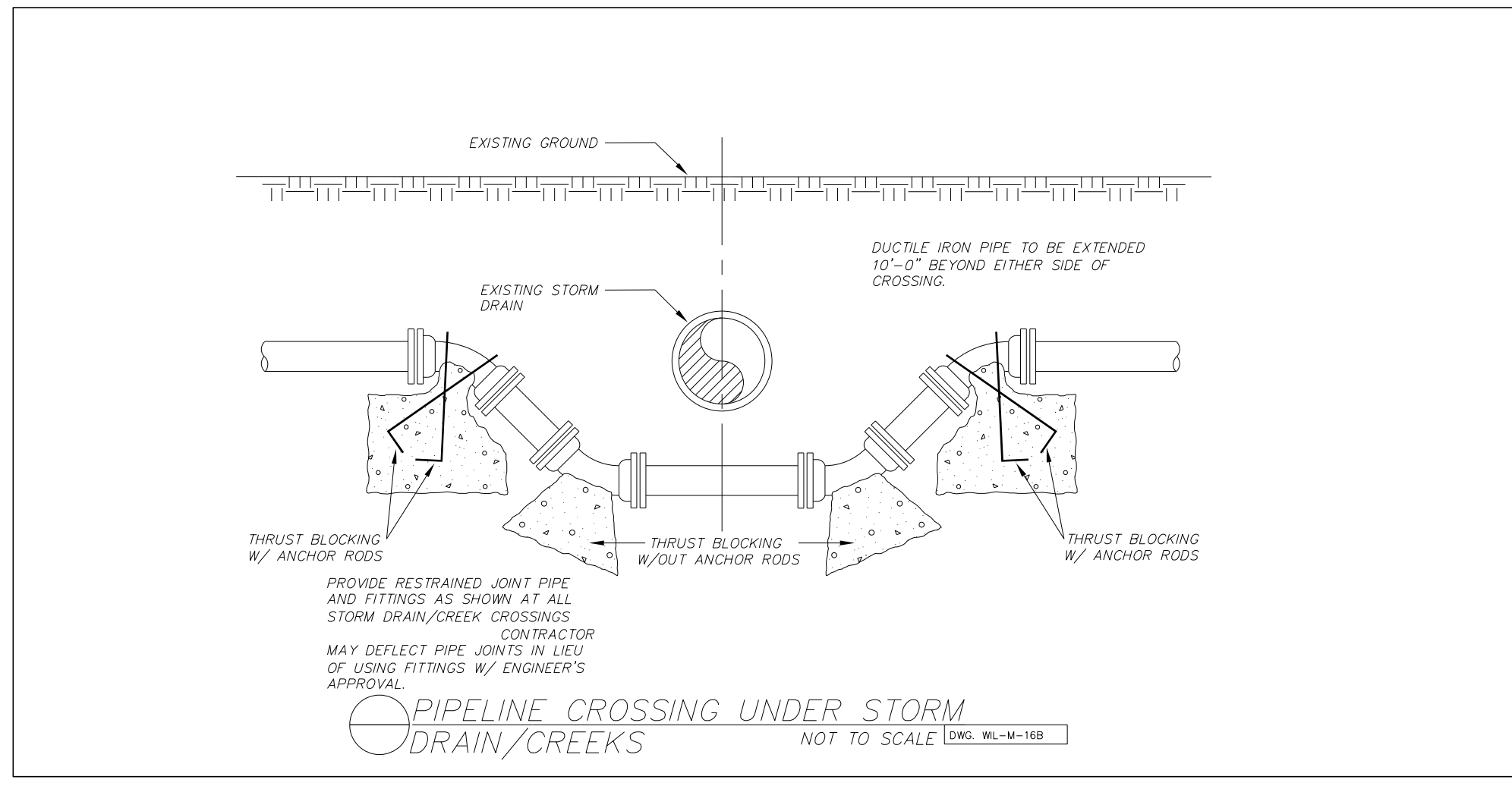
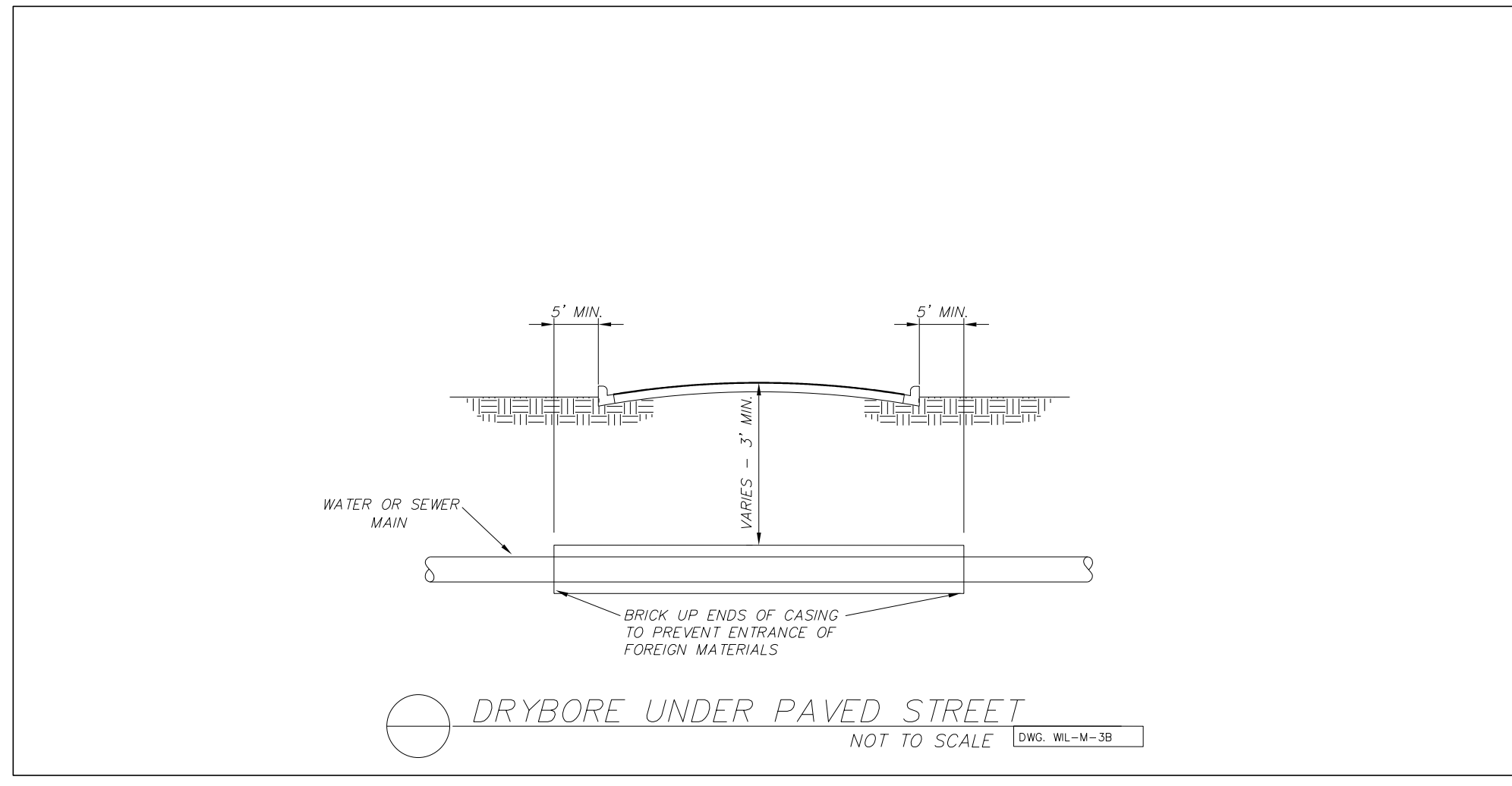
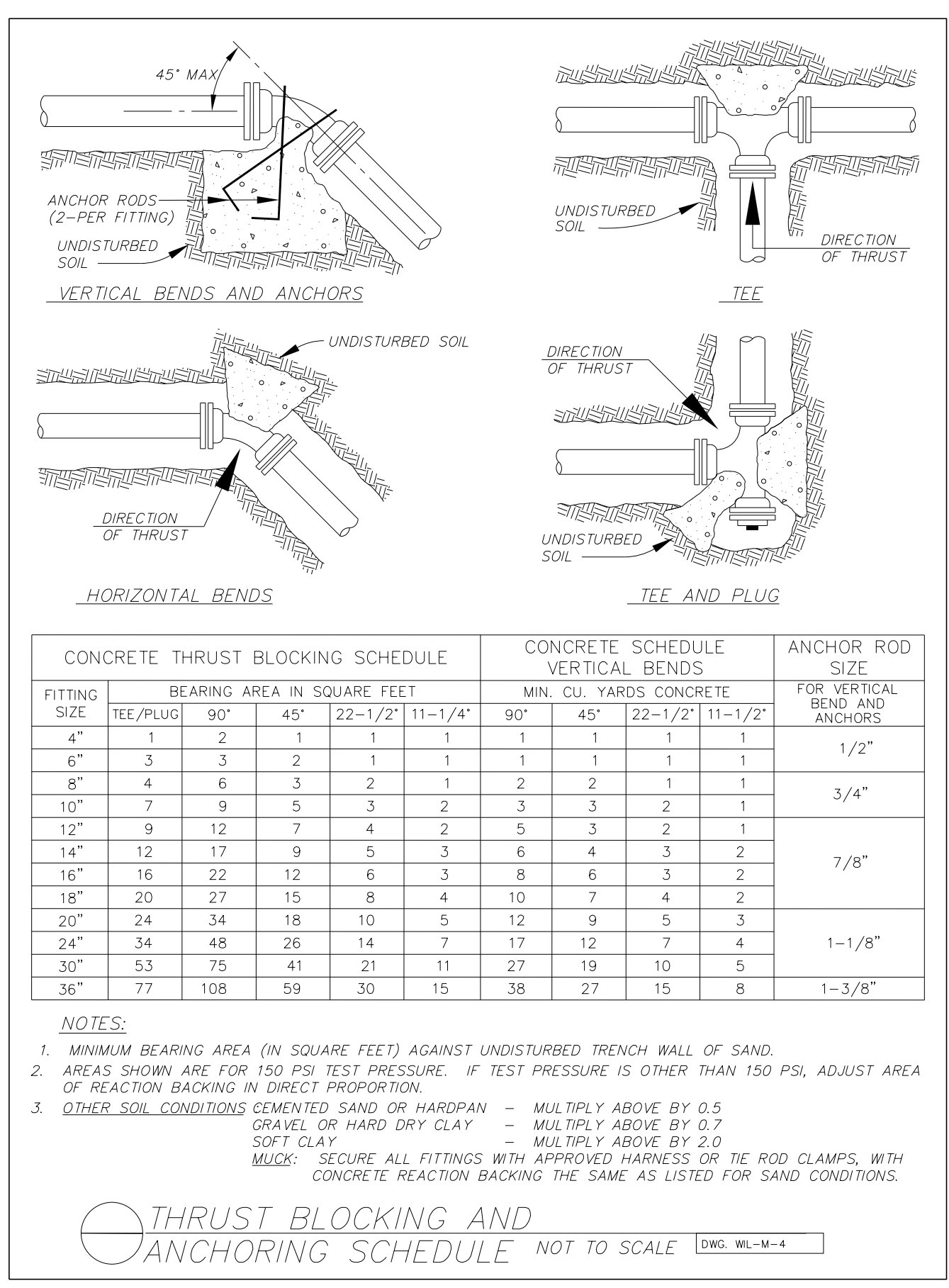
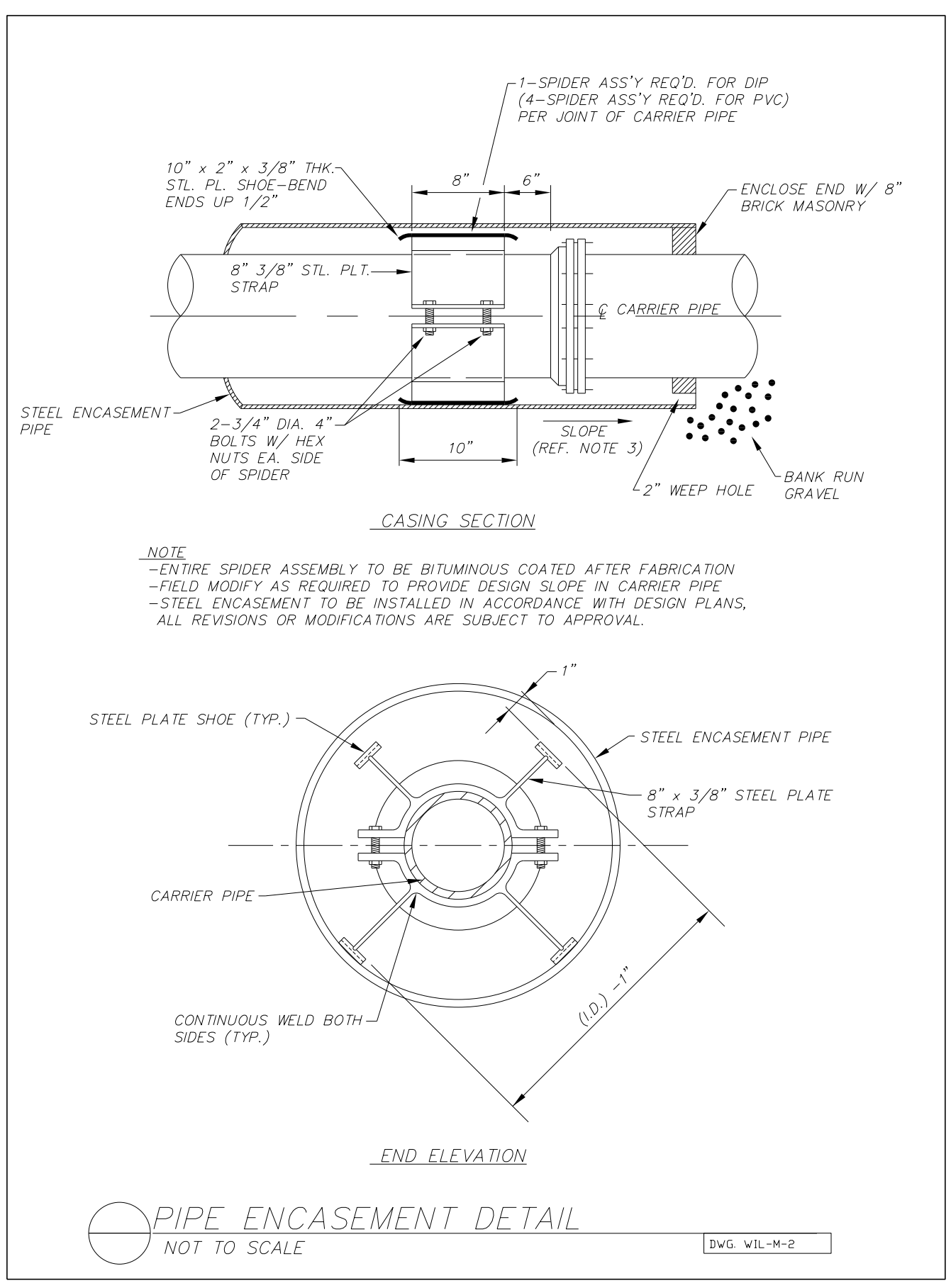

3/24/2012 10:47:05 AM UC40B-D-ps-h.dgn