

5/14/99

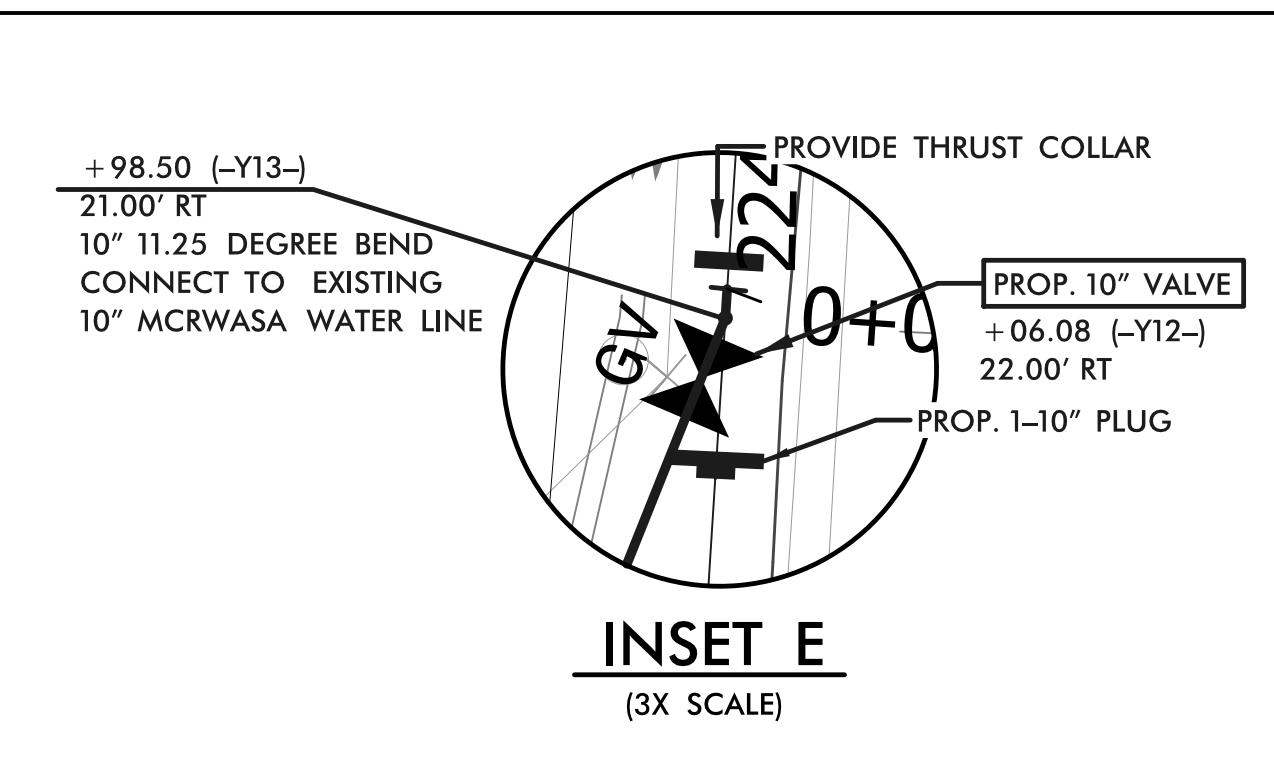
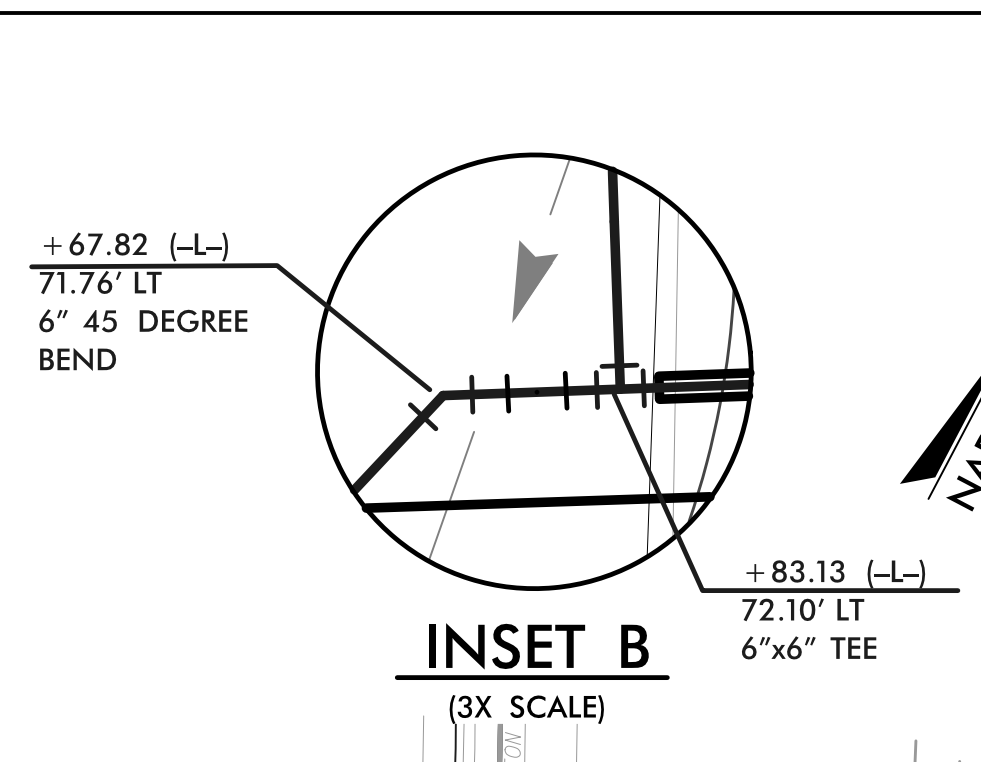
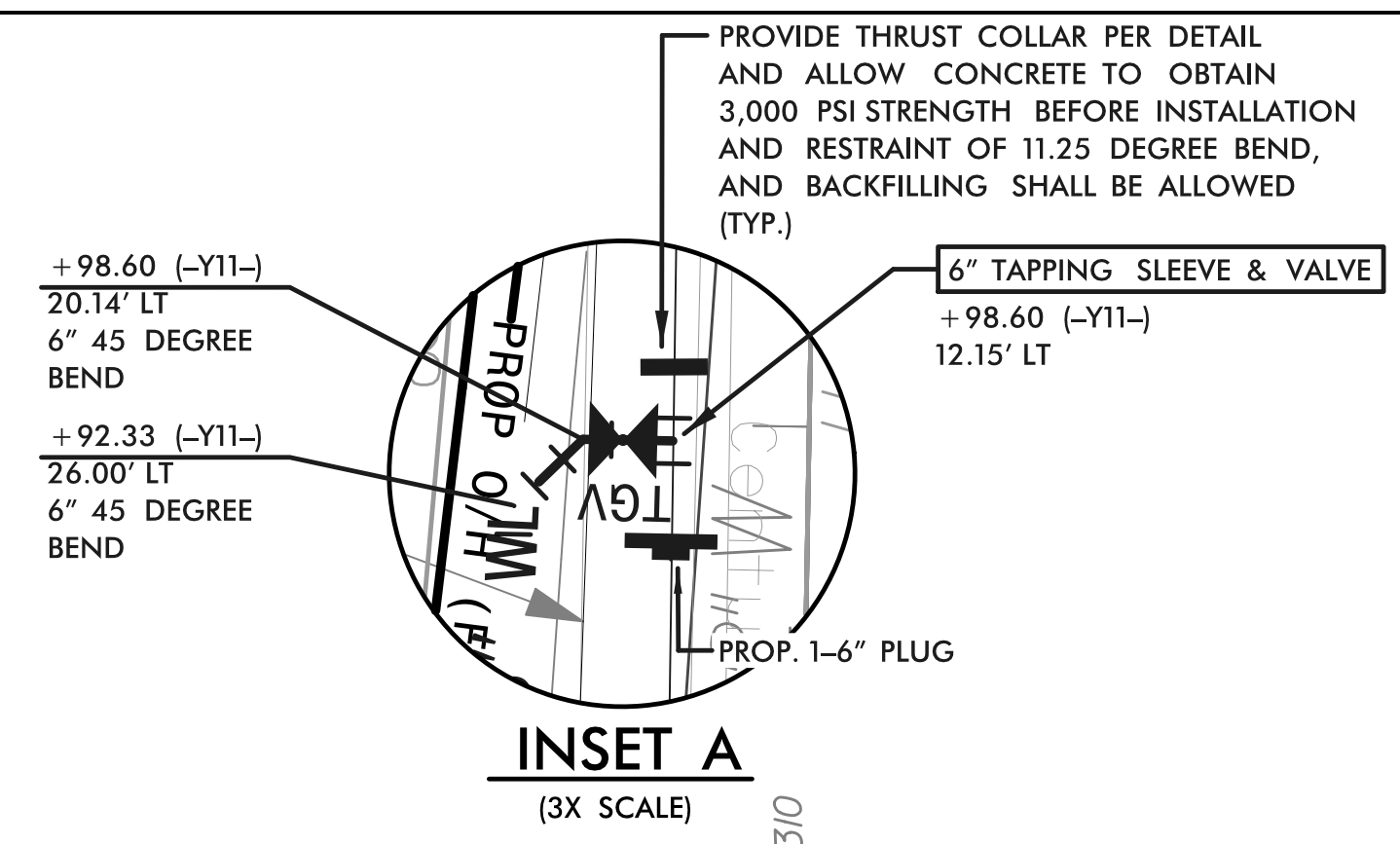

PREPARED IN THE OFFICE OF:

**THE WOOTEN COMPANY**  
301 West 14th Street, Greenville, NC 27834  
252.732.0096 Fax 252.732.3221  
Licenses: 1-4025

PROJECT REFERENCE NO.	SHEET NO.
R-4705	UC-21

DESIGNED BY: DCS  
DRAWN BY: TK8TH  
CHECKED BY: DCS  
APPROVED BY: DCS  
REVISED: 3-18-2022

**NORTH CAROLINA DEPARTMENT OF TRANSPORTATION**

UTILITIES ENGINEERING SEC.  
PHONE: (919) 707-6690  
FAX: (919) 250-4151

Document Not Considered Final Unless All Signatures Completed  
UTILITY CONSTRUCTION PLANS ONLY

**FINAL PLANS**  
RELEASED FOR CONSTRUCTION

**UTILITY CONSTRUCTION**

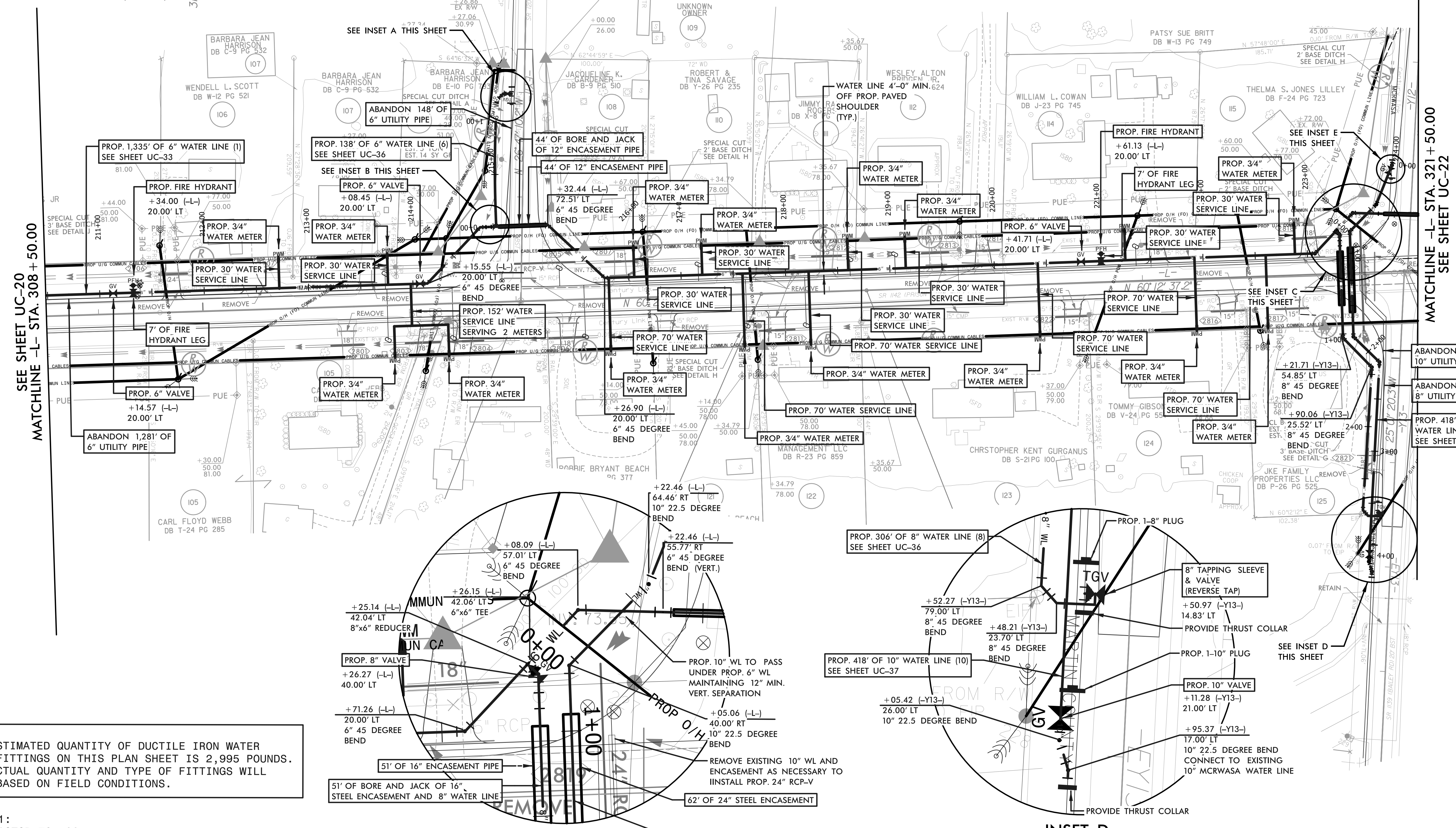

SEE SHEET UC-20  
MATCHLINE -L- STA. 308 + 50.00

MATCHLINE -L- STA. 321 + 50.00  
SEE SHEET UC-22

**NOTE:**  
THE ESTIMATED QUANTITY OF DUCTILE IRON WATER PIPE FITTINGS ON THIS PLAN SHEET IS 2,995 POUNDS. THE ACTUAL QUANTITY AND TYPE OF FITTINGS WILL VARY BASED ON FIELD CONDITIONS.

**NOTE 1:**  
CONTRACTOR TO LOCATE, VERIFY AND REPLACE ALL WATER METER SERVICES.

