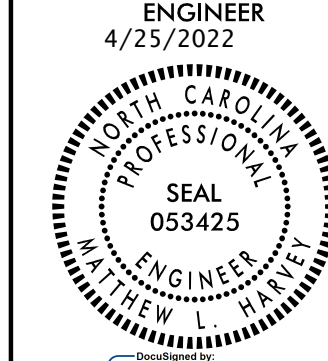

# DRAINAGE DETAILS

(NOT TO SCALE)

**WETHERILL ENGINEERING**  
 1223 Jones Franklin Rd.  
 Raleigh, N.C. 27606  
 License No. F-0377  
 Bus: 919 851 8077  
 Fax: 919 851 8107

TRANSPORTATION PLANNING/DESIGN - BRIDGE/STRUCTURE DESIGN  
 CIVIL/SITE DESIGN - GIS/GPS - CONSTRUCTION OBSERVATION

PROJECT REFERENCE NO. <b>R-4705</b>	SHEET NO. <b>2D-1</b>
HYDRAULICS ENGINEER 4/25/2022	
	

**DOCUMENT NOT CONSIDERED FINAL  
UNLESS ALL SIGNATURES COMPLETED**

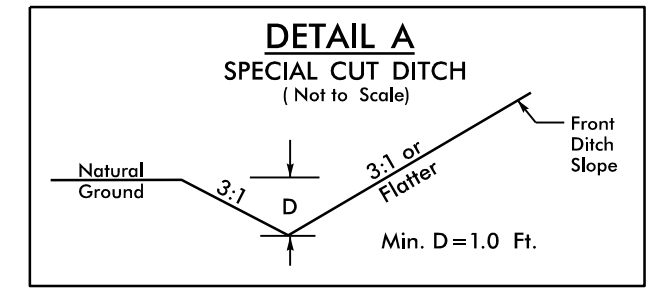

- FROM STA. 12+35 TO STA. 13+50 -Y1- LT
- FROM STA. 11+00 TO STA. 15+24 -L- RT
- FROM STA. 31+82 TO STA. 32+42 -L- RT
- FROM STA. 32+20 TO STA. 32+50 -L- LT
- FROM STA. 54+80 TO STA. 58+00 -L- LT
- FROM STA. 55+50 TO STA. 56+50 -L- RT
- FROM STA. 58+00 TO STA. 62+00 -L- LT
- FROM STA. 58+50 TO STA. 62+50 -L- RT
- FROM STA. 64+08 TO STA. 67+00 -L- RT
- FROM STA. 93+35 TO STA. 97+00 -L- LT
- FROM STA. 93+50 TO STA. 99+50 -L- RT
- FROM STA. 110+50 TO STA. 114+05 -L- RT
- FROM STA. 123+25 TO STA. 124+75 -L- RT
- FROM STA. 124+80 TO STA. 126+00 -L- RT
- FROM STA. 124+70 TO STA. 125+00 -L- LT
- FROM STA. 134+50 TO STA. 136+50 -L- RT
- FROM STA. 133+50 TO STA. 137+50 -L- LT
- FROM STA. 137+50 TO STA. 138+96 -L- LT
- FROM STA. 11+00 TO STA. 13+00 -Y3- LT
- FROM STA. 11+00 TO STA. 13+00 -Y3- RT
- FROM STA. 146+00 TO STA. 148+50 -L- LT
- FROM STA. 161+00 TO STA. 165+75 -L- RT
- FROM STA. 178+50 TO STA. 179+65 -L- RT
- FROM STA. 12+50 TO STA. 13+50 -Y5- RT
- FROM STA. 12+40 TO STA. 14+85 -Y6- LT
- FROM STA. 12+40 TO STA. 14+85 -Y6- RT
- FROM STA. 10+45 TO STA. 12+50 -Y7- LT
- FROM STA. 207+50 TO STA. 212+99 -L- RT
- FROM STA. 210+50 TO STA. 212+99 -L- LT
- FROM STA. 226+50 TO STA. 233+40 -L- RT
- FROM STA. 233+00 TO STA. 235+33 -L- LT
- FROM STA. 240+00 TO STA. 241+37 -L- RT
- FROM STA. 240+50 TO STA. 241+37 -L- LT
- FROM STA. 249+00 TO STA. 257+01 -L- RT
- FROM STA. 13+00 TO STA. 14+50 -Y9- RT
- FROM STA. 265+00 TO STA. 268+50 -L- RT
- FROM STA. 10+50 TO STA. 12+00 -Y10- LT
- FROM STA. 10+39 TO STA. 12+41 -Y11- RT
- FROM STA. 10+34 TO STA. 12+38 -Y11- LT
- FROM STA. 353+25 TO STA. 354+50 -L- LT
- FROM STA. 355+00 TO STA. 356+00 -L- RT
- FROM STA. 358+50 TO STA. 359+50 -L- LT
- FROM STA. 358+50 TO STA. 359+75 -L- RT
- FROM STA. 378+00 TO STA. 380+00 -L- LT
- FROM STA. 377+00 TO STA. 384+50 -L- RT
- FROM STA. 390+50 TO STA. 393+40 -L- RT
- FROM STA. 393+45 TO STA. 397+00 -L- RT
- FROM STA. 406+25 TO STA. 409+00 -L- RT
- FROM STA. 406+25 TO STA. 406+88 -L- LT
- FROM STA. 10+50 TO STA. 11+00 -Y18- LT
- FROM STA. 10+48 TO STA. 11+50 -Y26- LT
- FROM STA. 12+71 TO STA. 15+25 -Y19- LT
- FROM STA. 469+67 TO STA. 470+25 -L- RT.

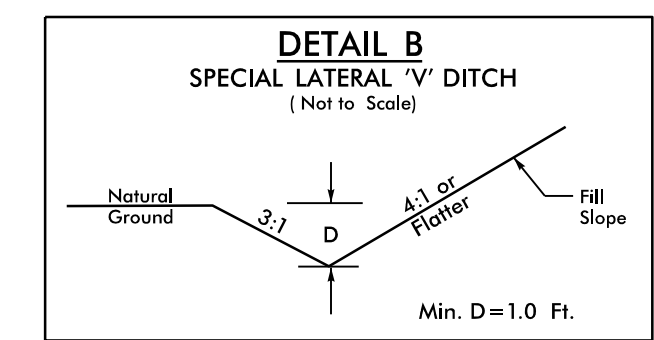

- FROM STA. 18+00 TO STA. 20+00 -Y1- RT
- FROM STA. 20+12 TO STA. 21+50 -Y1- RT
- FROM STA. 22+25 TO STA. 25+00 -Y1- RT
- FROM STA. 21+50 TO STA. 25+50 -L- RT
- FROM STA. 26+20 TO STA. 31+50 -L- RT
- FROM STA. 73+00 TO STA. 74+50 -L- LT
- FROM STA. 103+00 TO STA. 105+30 -L- RT
- FROM STA. 109+65 TO STA. 114+05 -L- LT
- FROM STA. 11+75 TO STA. 14+50 -Y2- RT
- FROM STA. 13+00 TO STA. 14+50 -Y2- LT
- FROM STA. 194+55 TO STA. 197+00 -L- LT
- FROM STA. 257+01 TO STA. 262+00 -L- RT

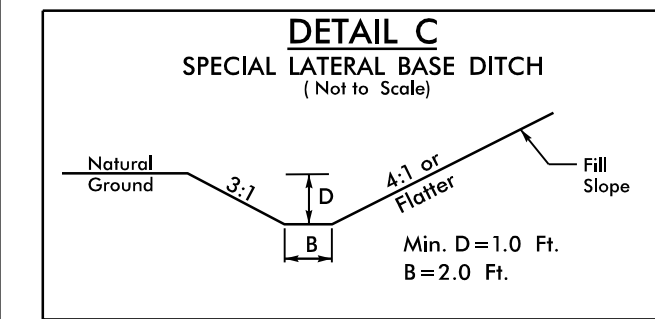

- FROM STA. 12+35 TO STA. 17+00 -Y1- RT
- FROM STA. 10+50 TO STA. 19+00 -L- LT
- FROM STA. 21+65 TO STA. 31+80 -L- LT
- FROM STA. 105+70 TO STA. 108+00 -L- LT
- FROM STA. 138+96 TO STA. 144+50 -L- RT
- FROM STA. 448+85 TO STA. 451+00 -L- RT

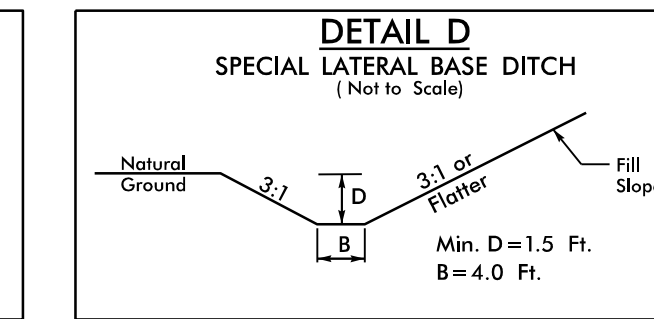

- FROM STA. 15+24 TO STA. 21+48 -L- RT

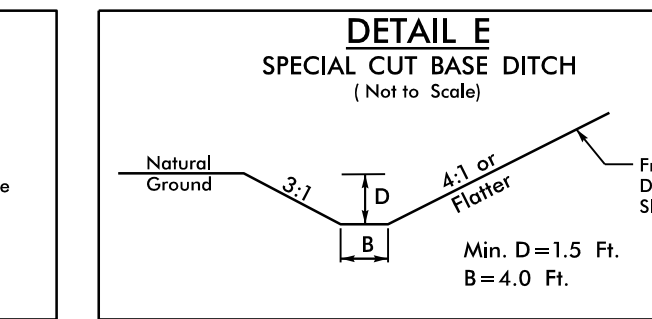

- FROM STA. 62+50 TO STA. 64+02 -L- RT
- FROM STA. 165+80 TO STA. 167+65 -L- RT

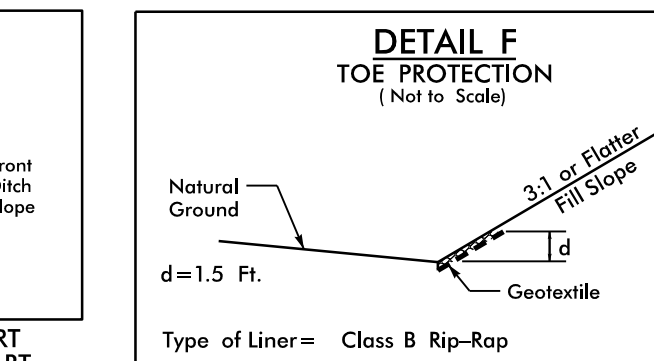

- FROM STA. 73+18 TO STA. 83+00 -L- RT
- FROM STA. 74+80 TO STA. 77+80 -L- LT
- FROM STA. 78+25 TO STA. 83+50 -L- LT

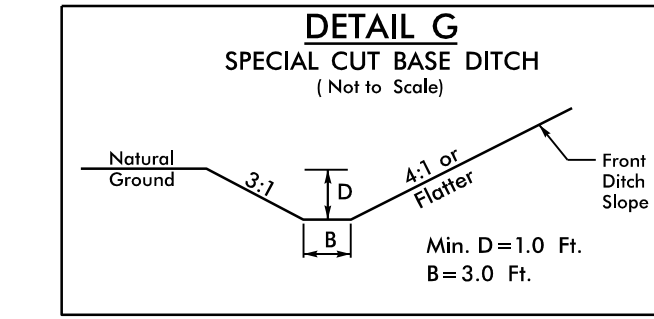

- FROM STA. 62+00 TO STA. 62+50 -L- LT
- FROM STA. 62+50 TO STA. 63+85 -L- LT
- FROM STA. 64+15 TO STA. 71+00 -L- LT
- FROM STA. 113+88 TO STA. 115+00 -L- LT
- FROM STA. 179+65 TO STA. 188+05 -L- RT
- FROM STA. 179+50 TO STA. 185+40 -L- LT
- FROM STA. 13+50 TO STA. 15+25 -Y13- LT

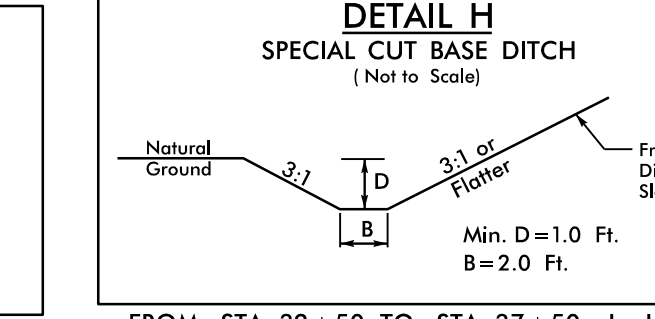

- FROM STA. 32+50 TO STA. 37+50 -L- LT
- FROM STA. 32+42 TO STA. 39+20 -L- RT
- FROM STA. 40+50 TO STA. 51+80 -L- LT
- FROM STA. 40+00 TO STA. 52+30 -L- RT
- FROM STA. 100+50 TO STA. 105+70 -L- LT
- FROM STA. 114+05 -L- RT DRIVEWAY
- FROM STA. 115+05 TO STA. 124+35 -L- LT
- FROM STA. 138+96 TO STA. 145+50 -L- RT
- FROM STA. 148+60 TO STA. 160+00 -L- LT
- FROM STA. 153+87 TO STA. 161+00 -L- LT
- FROM STA. 160+00 TO STA. 165+75 -L- LT
- FROM STA. 165+80 TO STA. 174+65 -L- LT
- FROM STA. 167+65 TO STA. 174+65 -L- RT
- FROM STA. 188+05 TO STA. 192+10 -L- RT
- FROM STA. 186+25 TO STA. 192+50 -L- LT
- FROM STA. 197+03 TO STA. 207+00 -L- LT
- FROM STA. 194+00 TO STA. 220+20 -L- RT
- FROM STA. 212+99 TO STA. 223+25 -L- LT
- FROM STA. 212+99 TO STA. 222+00 -L- RT
- FROM STA. 223+50 TO STA. 232+50 -L- LT
- FROM STA. 227+55 TO STA. 239+50 -L- RT
- FROM STA. 235+33 TO STA. 240+00 -L- LT
- FROM STA. 241+37 TO STA. 245+30 -L- LT
- FROM STA. 247+00 TO STA. 252+90 -L- LT
- FROM STA. 253+00 TO STA. 262+00 -L- LT
- FROM STA. 267+15 TO STA. 274+40 -L- LT
- FROM STA. 275+50 TO STA. 303+80 -L- LT
- FROM STA. 276+00 TO STA. 317+00 -L- RT
- FROM STA. 312+26 TO STA. 313+00 -L- RT
- FROM STA. 315+80 TO STA. 317+00 -L- RT
- FROM STA. 10+39 TO STA. 12+41 -Y11- RT
- FROM STA. 10+40 TO STA. 12+00 -Y12- LT
- FROM STA. 313+67 TO STA. 316+50 -L- LT
- FROM STA. 332+00 TO STA. 338+00 -L- LT
- FROM STA. 324+95 TO STA. 338+75 -L- RT
- FROM STA. 338+00 TO STA. 353+23 -L- LT
- FROM STA. 339+08 TO STA. 352+69 -L- RT
- FROM STA. 367+00 TO STA. 372+00 -L- RT
- FROM STA. 393+65 TO STA. 406+00 -L- LT
- FROM STA. 406+88 TO STA. 414+50 -L- LT

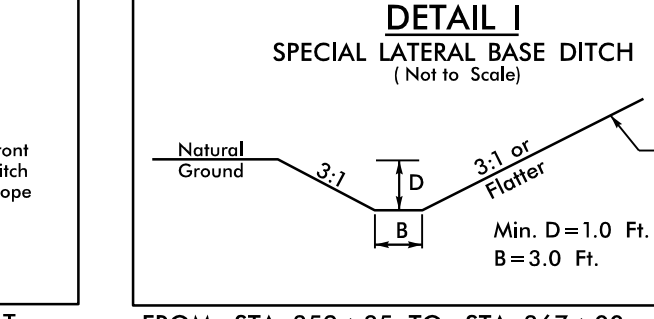

- FROM STA. 359+85 TO STA. 367+00 -L- RT
- FROM STA. 359+75 TO STA. 368+40 -L- LT
- FROM STA. 390+50 TO STA. 393+59 -L- LT
- FROM STA. 476+00 TO STA. 480+00 -L- LT

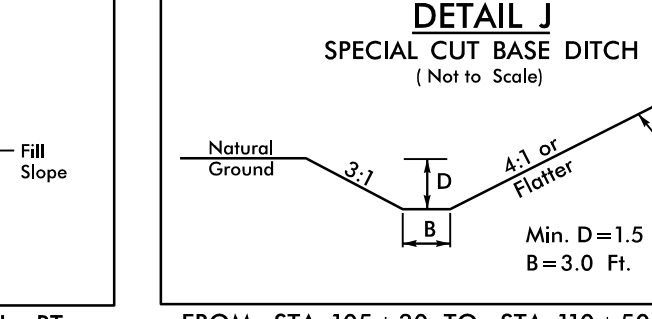

- FROM STA. 105+30 TO STA. 110+50 -L- RT
- FROM STA. 146+00 TO STA. 148+00 -L- RT
- FROM STA. 148+60 TO STA. 152+80 -L- RT
- FROM STA. 241+37 TO STA. 249+00 -L- RT
- FROM STA. 262+50 TO STA. 267+15 -L- LT
- FROM STA. 303+80 TO STA. 312+50 -L- LT
- FROM STA. 12+62 TO STA. 14+50 -Y19- RT

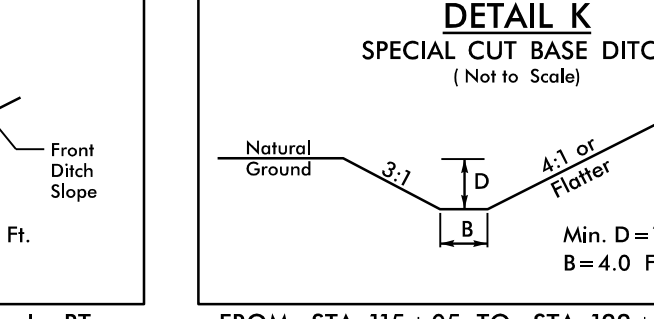

- FROM STA. 115+05 TO STA. 122+94 -L- RT

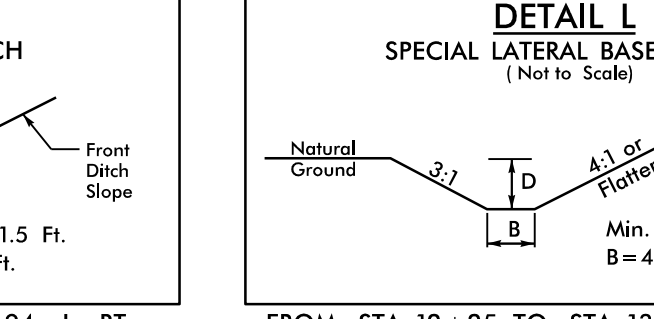

- FROM STA. 12+25 TO STA. 13+00 -Y2- LT
- FROM STA. 325+00 TO STA. 332+00 -L- LT

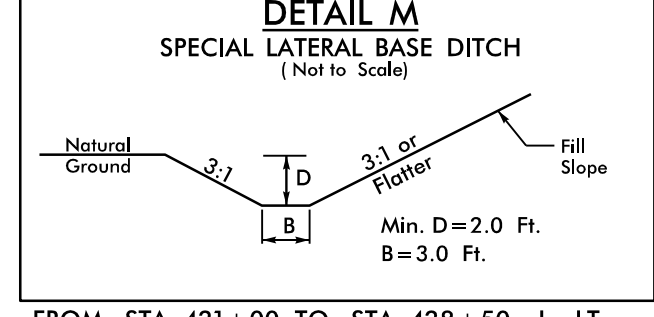

- FROM STA. 421+00 TO STA. 428+50 -L- LT
- FROM STA. 480+00 TO STA. 490+66 -L- LT

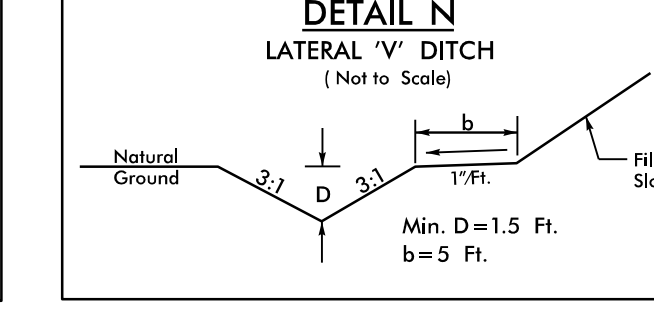

- FROM STA. 452+00 TO STA. 455+88 -L- LT

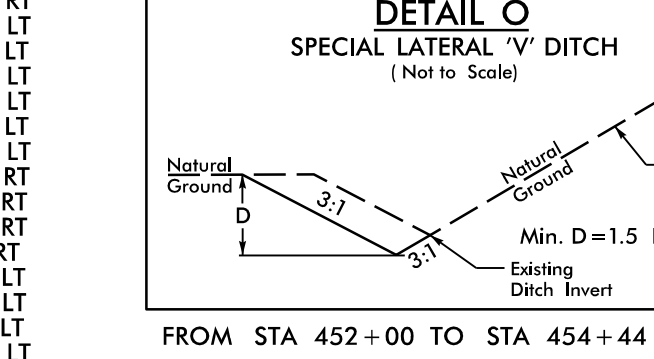

- FROM STA. 452+00 TO STA. 454+44 -L- RT

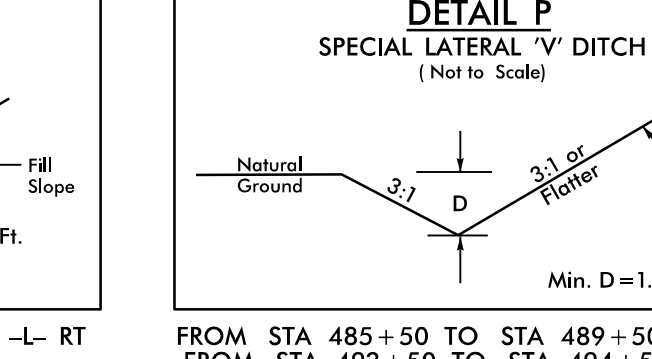

- FROM STA. 485+50 TO STA. 489+50 -L- RT
- FROM STA. 492+50 TO STA. 494+50 -L- LT
- FROM STA. 498+75 TO STA. 503+40 -L- RT
- FROM STA. 504+00 TO STA. 506+00 -L- RT
- FROM STA. 507+00 TO STA. 507+50 -L- RT
- FROM STA. 509+00 TO STA. 513+00 -L- RT
- FROM STA. 510+00 TO STA. 512+50 -L- LT

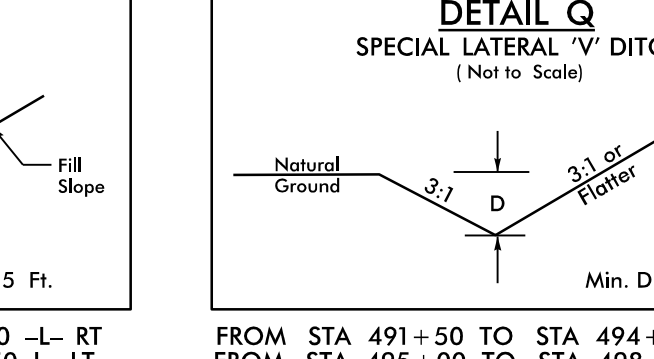

- FROM STA. 491+50 TO STA. 494+00 -L- RT
- FROM STA. 495+00 TO STA. 498+65 -L- RT
- FROM STA. 513+58 TO STA. 516+50 -L- RT

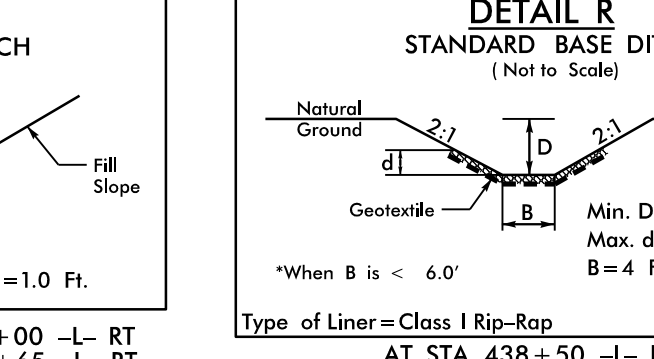

- AT STA. 438+50 -L- RT.

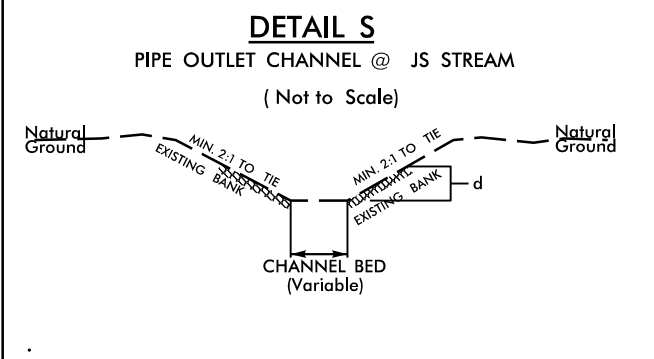

- STA. 22+00 -Y1- LT; L=14'; d=3.0'
- STA. 21+47 -L- RT; L=14'; d=3.0'
- STA. 115+05 -L- RT; L=12'; d=2.0'
- STA. 124+71 -L- LT; L=14'; d=3.0'
- STA. 148+56 -L- LT; L=14'; d=3.0'
- STA. 324+92 -L- RT; L=16'; d=2.5'
- STA. 359+80 -L- RT; L=20'; d=4.0'
- STA. 379+43 -L- RT; L=16'; d=4.0'
- STA. 393+45 -L- RT; L=20'; d=4.0'
- STA. 498+69 -L- RT; L=12'; d=4.0'
- STA. 513+45 -L- RT; L=14'; d=3.5'