

8/17/99

PAVEMENT SCHEDULE (FINAL PAVEMENT DESIGN, MEMO DATED 1/31/2018)	
C1	PROP. APPROX. 1½" ASPHALT CONCRETE SURFACE COURSE, TYPE S9.5B, AT AN AVERAGE RATE OF 165 LBS. PER SQ. YD.
C2	PROP. APPROX. 3" ASPHALT CONCRETE SURFACE COURSE, TYPE S9.5B, AT AN AVERAGE RATE OF 165 LBS. PER SQ. YD. IN EACH OF TWO LAYERS.
C3	PROP. VAR. DEPTH ASPHALT CONCRETE SURFACE COURSE, TYPE S9.5B, AT AN AVERAGE RATE OF 110 LBS. PER SQ. YD. PER 1" DEPTH. TO BE PLACED IN LAYERS NOT TO EXCEED 1½" IN DEPTH.
D1	PROP. APPROX. 2½" ASPHALT CONCRETE INTERMEDIATE COURSE, TYPE I19.0C, AT AN AVERAGE RATE OF 285 LBS. PER SQ. YD.
D2	PROP. VAR. DEPTH ASPHALT CONCRETE INTERMEDIATE COURSE, TYPE I19.0C, AT AN AVERAGE RATE OF 114 LBS. PER SQ. YD. PER 1" DEPTH. TO BE PLACED IN LAYERS NOT LESS THAN 2½" IN DEPTH OR GREATER THAN 4" IN DEPTH.
E1	PROP. APPROX. 4" ASPHALT CONCRETE BASE COURSE, TYPE B25.0C, AT AN AVERAGE RATE OF 456 LBS. PER SQ. YD.
E2	PROP. APPROX. 5" ASPHALT CONCRETE BASE COURSE, TYPE B25.0C, AT AN AVERAGE RATE OF 570 LBS. PER SQ. YD.
E3	PROP. APPROX. 8" ASPHALT CONCRETE BASE COURSE, TYPE B25.0C, AT AN AVERAGE RATE OF 456 LBS. PER SQ. YD. IN EACH OF TWO LAYERS.
E4	PROP. VAR. DEPTH ASPHALT CONCRETE BASE COURSE, TYPE B25.0C, AT AN AVERAGE RATE OF 114 LBS. PER SQ. YD. PER 1" DEPTH. TO BE PLACED IN LAYERS NOT LESS THAN 3" IN DEPTH OR GREATER THAN 5½" IN DEPTH.
R1	EXIST. CONCRETE CURB
R2	EXIST. CONCRETE ISLAND
R3	2'-6" CONCRETE CURB & GUTTER
R4	EXPRESSWAY GUTTER
R5	SHOULDER BERM GUTTER
T	EARTH MATERIAL
U	EXISTING PAVEMENT
V	MILLING ASPHALT PAVEMENT, 1½" DEPTH
W	VARIABLE DEPTH ASPHALT PAVEMENT (SEE WEDGING DETAIL.)

NOTE: PAVEMENT EDGE SLOPES ARE 1:1 UNLESS SHOWN OTHERWISE.

WETHERILL ENGINEERING
 1223 Jones Franklin Rd.
 Raleigh, N.C. 27606
 License No. F-0377
 Bus: 919 851 8077
 Fax: 919 851 8107

TRANSPORTATION PLANNING/DESIGN - BRIDGE/STRUCTURE DESIGN
 CIVIL/SITE DESIGN - GIS/GPS - CONSTRUCTION OBSERVATION

DOCUMENT NOT CONSIDERED FINAL UNLESS ALL SIGNATURES COMPLETED

PROJECT REFERENCE NO. R-4705	SHEET NO. 2A-1
ROADWAY DESIGN ENGINEER 4/7/2022 	PAVEMENT DESIGN ENGINEER 4/8/2022

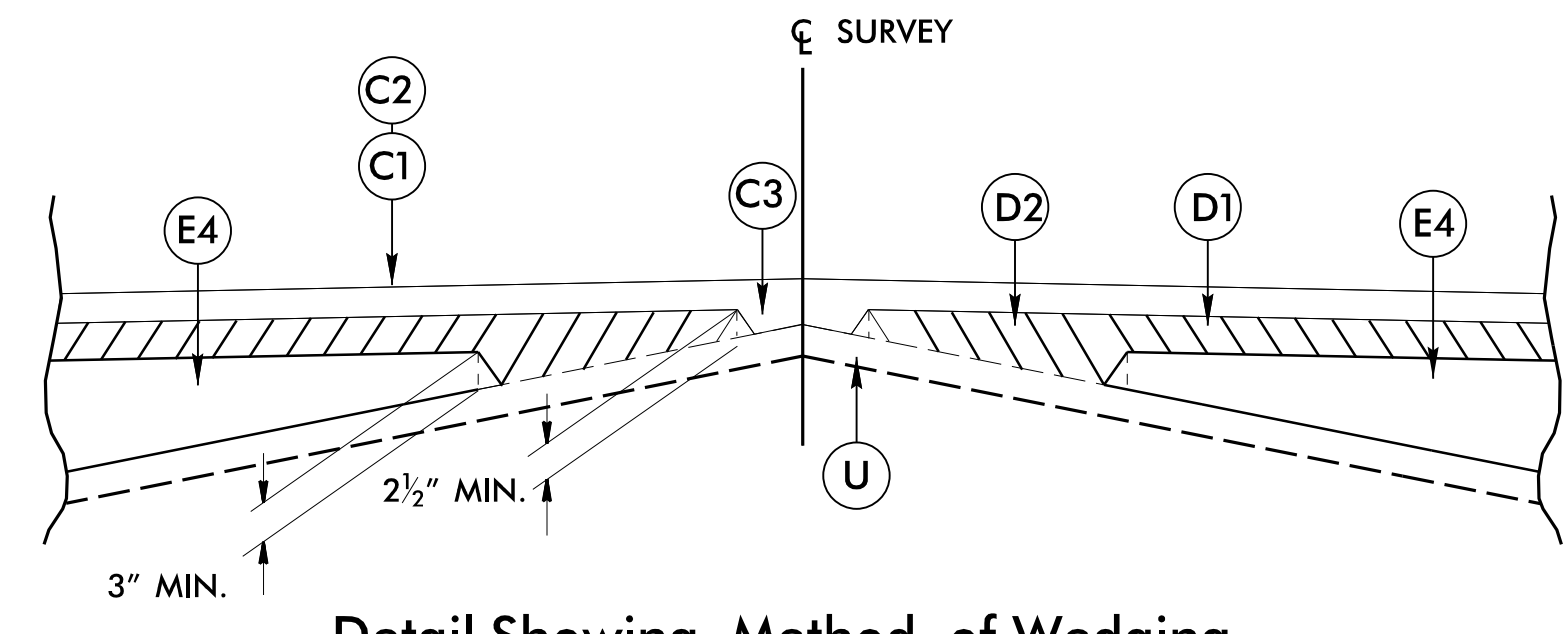

Detail Showing Method of Wedging

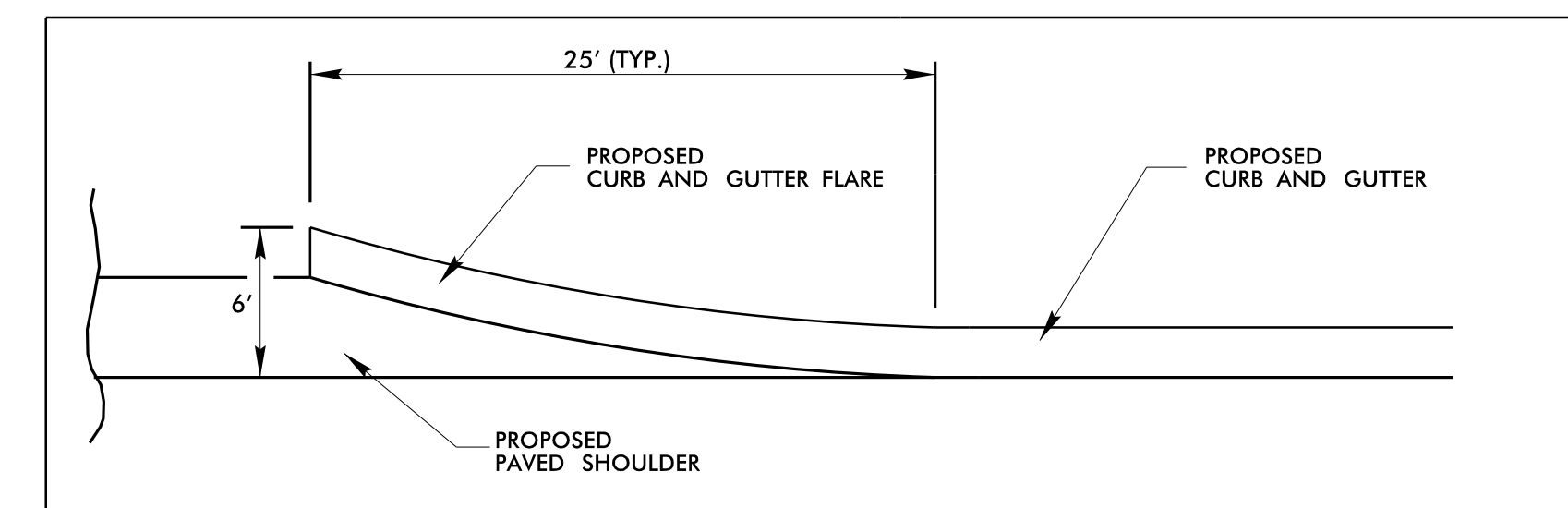

Detail Showing Approach Flare of Curb and Gutter

NOTE: DRAWING NOT TO SCALE

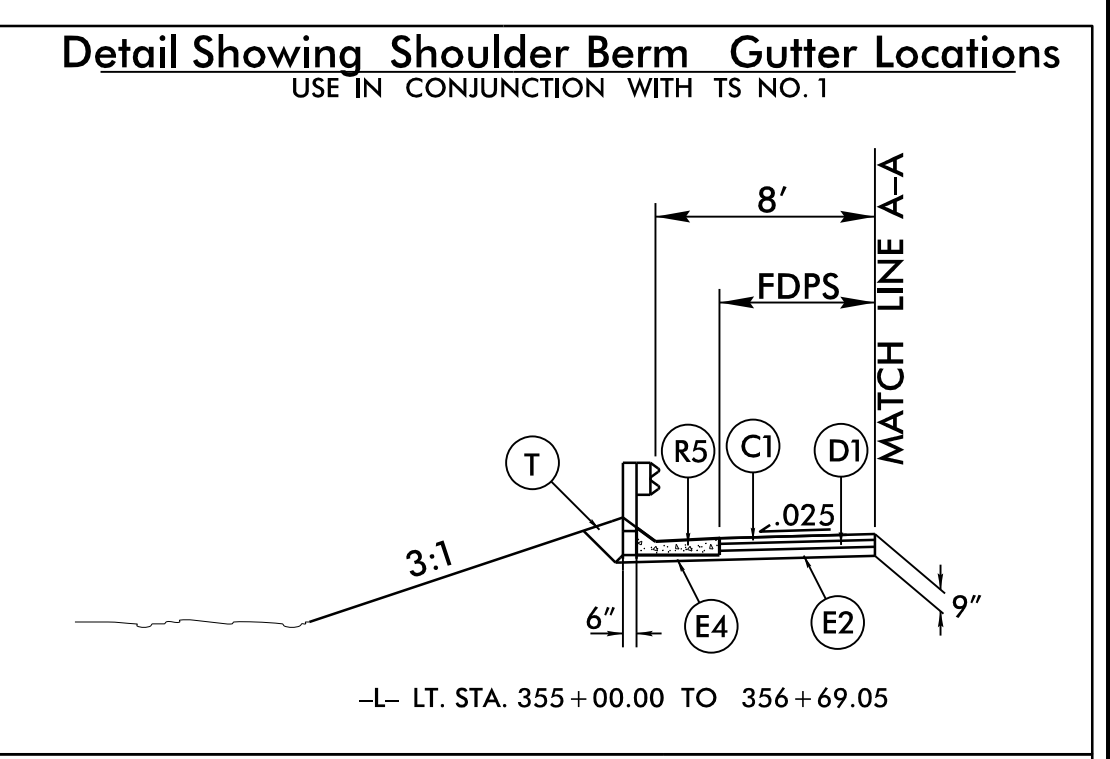
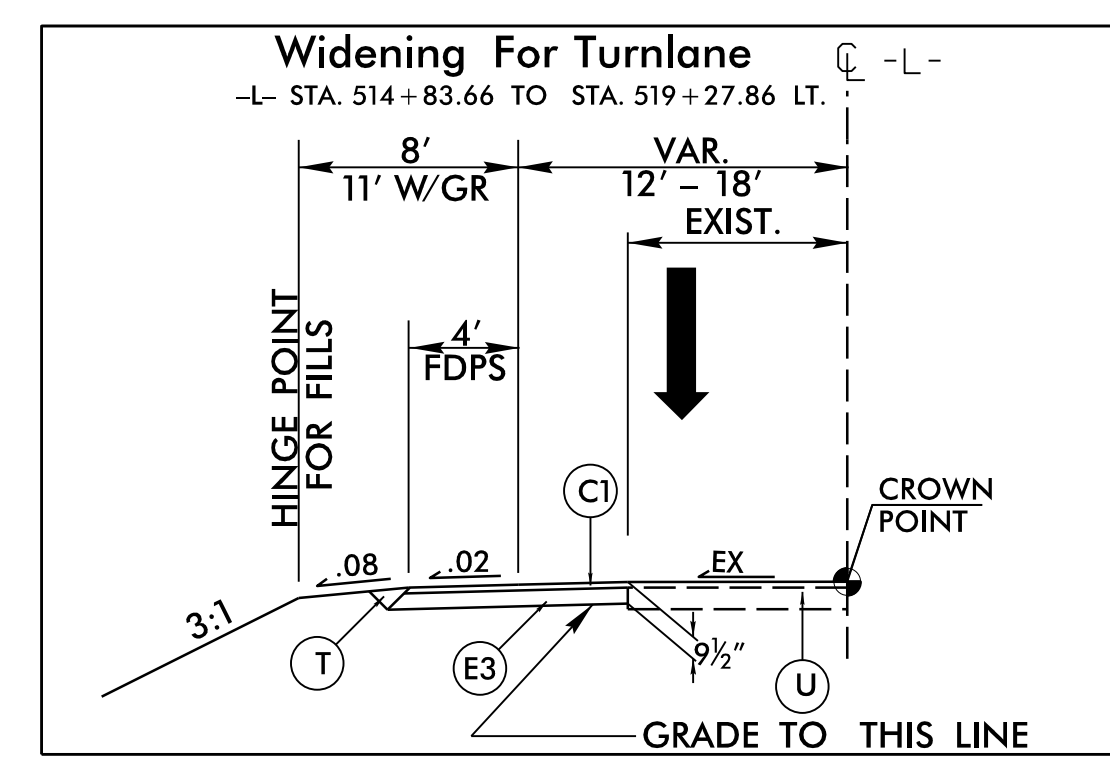

Detail Showing Shoulder Berm Gutter Locations

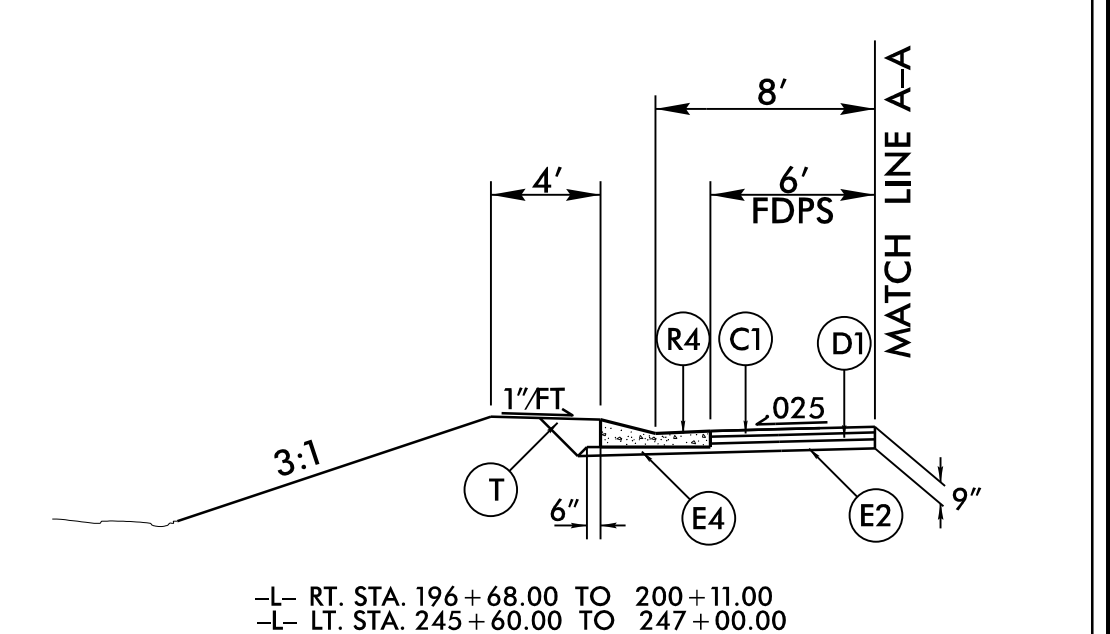

Detail Showing Expressway Gutter Locations

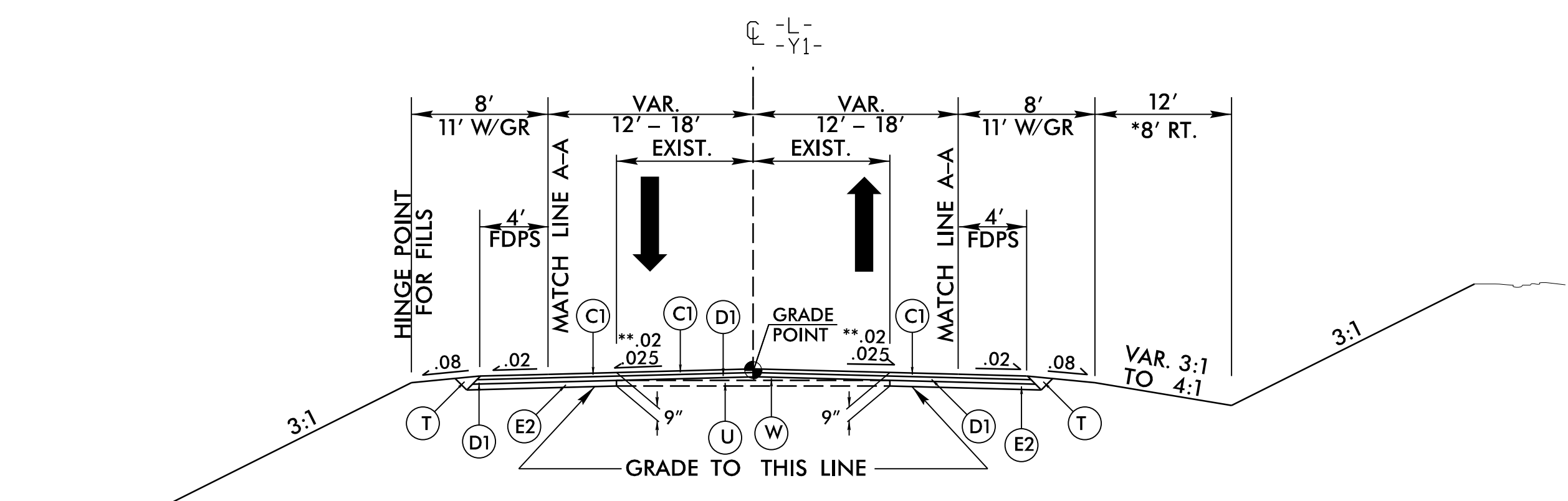

TYPICAL SECTION NO. 1

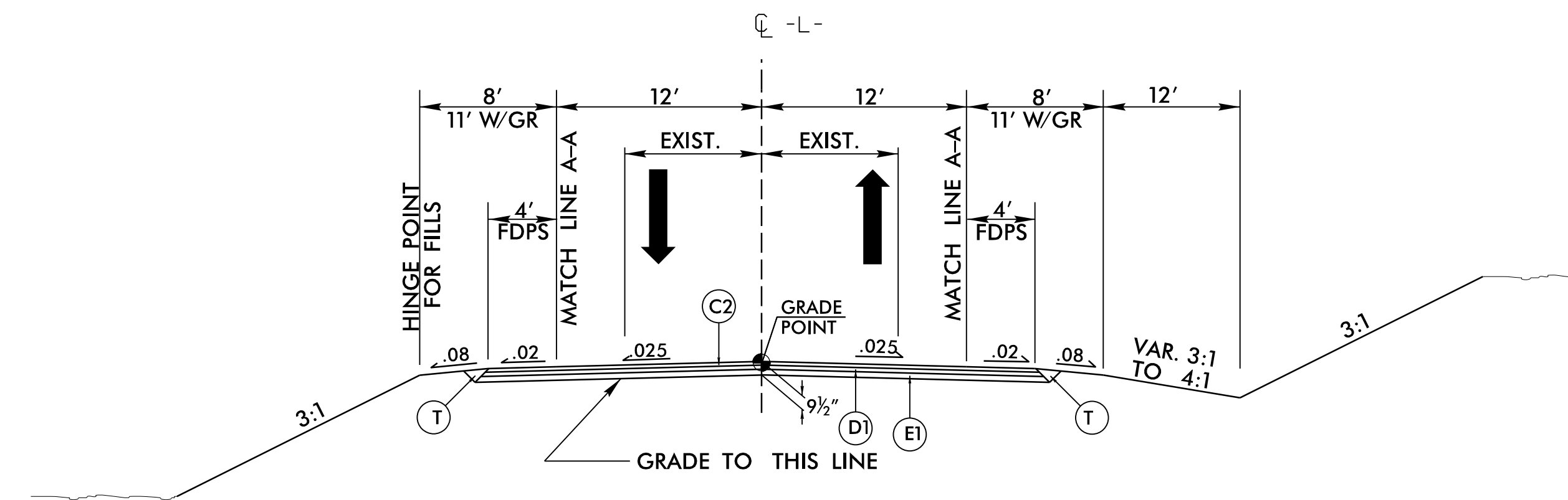

TYPICAL SECTION NO. 2

- USE TYPICAL SECTION NO. 1
- L- STA. 10+18.13 TO STA. 53+44.00
 - L- STA. 53+97.00 TO STA. 68+00.00
 - L- STA. 75+50.00 TO STA. 84+01.97
 - L- STA. 91+47.97 TO STA. 108+00.00
 - L- STA. 110+50.00 TO STA. 200+00.00
 - L- STA. 200+00.00 TO STA. 222+00.00
 - L- STA. 222+00.00 TO STA. 325+00.00
 - L- STA. 325+00.00 TO STA. 359+50.00
 - L- STA. 359+89.00 TO STA. 393+35.00
 - L- STA. 393+35.00 TO STA. 411+79.77
 - Y1- STA. 12+34.37 TO STA. 24+84.37
 - L- STA. 455+5363 TO STA. 459+73.25 (BEG. EXIST. BRIDGE)
 - L- STA. 461+97.14 (END EXIST. BRIDGE) TO STA. 471+00.00

NOTE: MILL EXISTING PAVEMENT 1½" AND RESURFACE WITH 1½" S9.5B -L- STA. 84+01.97 TO 91+41.97

- USE TYPICAL SECTION NO. 2
- L- STA. 53+44.00 TO STA. 53+97.00
 - L- STA. 68+00.00 TO STA. 75+50.00
 - L- STA. 108+00.00 TO STA. 110+50.00
 - L- STA. 359+50.00 TO STA. 359+89.00
 - L- STA. 393+35.00 TO STA. 393+73.00

REVISIONS

3/24/2022
 14705_Pd.dwg - 02a - 1.dgn
 TISSERAND