

**This electronic collection of documents is provided  
for the convenience of the user  
and is Not a Certified Document –**

**The documents contained herein were originally issued  
and sealed by the individuals whose names and license  
numbers appear on each page, on the dates appearing  
with their signature on that page.**

**This file or an individual page  
shall not be considered a certified document.**

**TIP PROJECT: I-5915B**

**CONTRACT: C204719**

STATE OF NORTH CAROLINA

DIVISION OF HIGHWAYS

# CATAWBA & IREDELL COUNTIES

STATE	STATE PROJECT REFERENCE NO.	SHEET NO.	TOTAL SHEETS
N.C.	I-5915B	1	214
STATE PROJ. NO.	F.A. PROJ. NO.	DESCRIPTION	
45919.1.1	0040102	P.E.	
45919.3.3	0040102	CONST.	

**LOCATION: BRIDGES 170171, 170172, 170177, 170178, 480006, 480007, 480051, 480054, 480065, 480066, 480072, 480073, 480096, 480102, 480104, 480109, 480123, 480124 ON THE I-40 CORRIDOR BETWEEN HICKORY AND STATESVILLE**

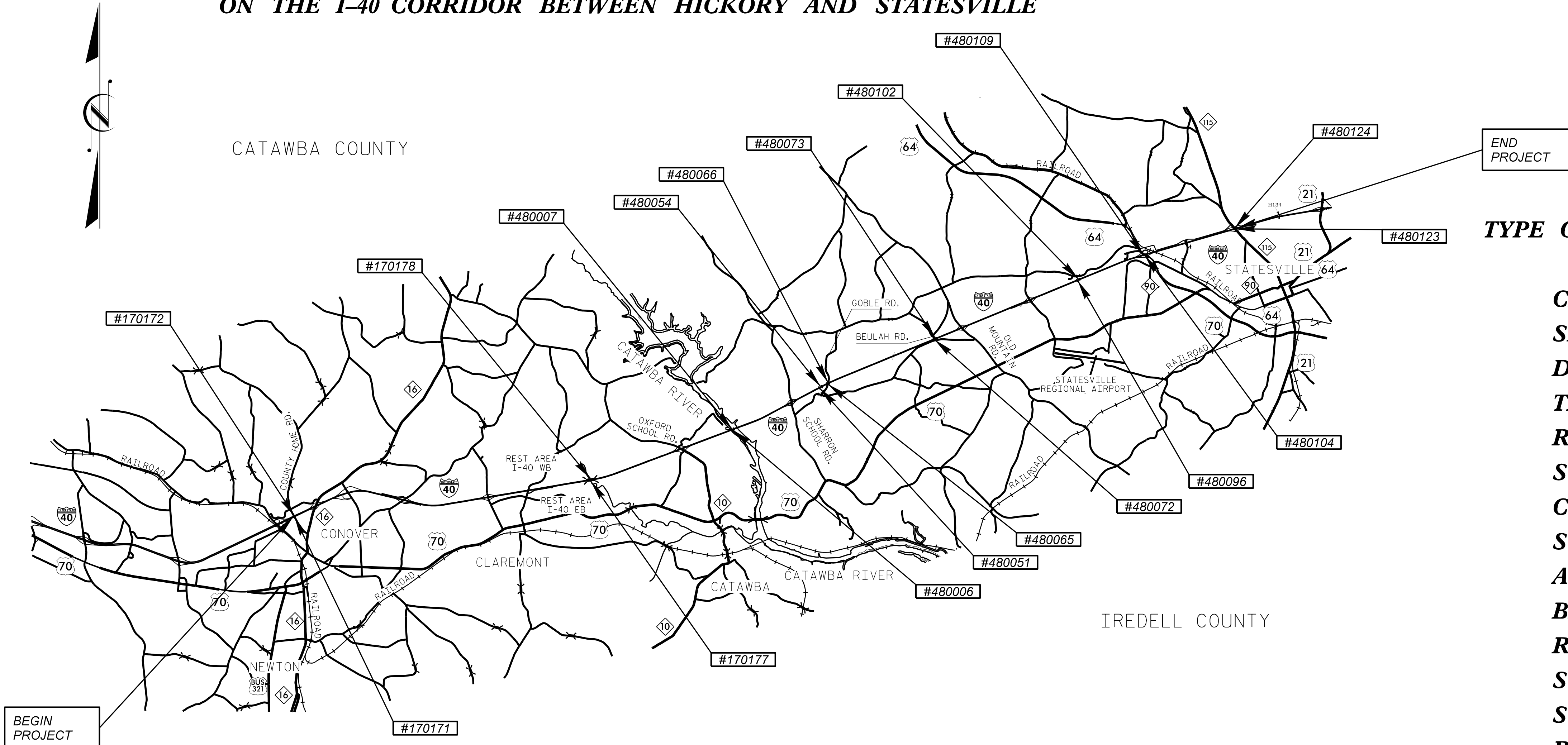

**TYPE OF WORK: BRIDGE PRESERVATION**

**CLEANING DEBRIS FROM SHOULDERS, SLOPES, AND SUBSTRUCTURE; DECK REPAIRS; SILANE DECK TREATMENT; JOINT REPAIRS / REPLACEMENT; ADD ASPHALT WEARING SURFACE (AWS); LATEX MODIFIED CONCRETE OVERLAY - VERY EARLY STRENGTH; BRIDGE JACKING, CLEANING AND PAINTING EXISTING STEEL BEARINGS AND GIRDER ENDS; BEARING REPAIR; EPOXY RESIN INJECTION; SUPERSTRUCTURE REPAIRS; SUBSTRUCTURE REPAIRS, EROSION REMEDIATION, APPROACH ROADWAY MILLING AND RESURFACING**

## STRUCTURES

**DESIGN DATA & PROJECT LENGTH**

BRIDGE #170171	ADT	2017	=	30,000	LENGTH	=	0.026 MI.	BRIDGE #480072	ADT	2013	=	20,250	LENGTH	=	0.023 MI.
BRIDGE #170172	ADT	2017	=	30,000	LENGTH	=	0.030 MI.	BRIDGE #480073	ADT	2013	=	20,250	LENGTH	=	0.023 MI.
BRIDGE #170177	ADT	2019	=	21,000	LENGTH	=	0.034 MI.	BRIDGE #480096	ADT	2013	=	21,500	LENGTH	=	0.034 MI.
BRIDGE #170178	ADT	2019	=	21,000	LENGTH	=	0.034 MI.	BRIDGE #480102	ADT	2013	=	21,500	LENGTH	=	0.034 MI.
BRIDGE #480006	ADT	2013	=	19,500	LENGTH	=	0.172 MI.	BRIDGE #480104	ADT	2013	=	24,000	LENGTH	=	0.045 MI.
BRIDGE #480007	ADT	2013	=	19,500	LENGTH	=	0.173 MI.	BRIDGE #480109	ADT	2013	=	22,750	LENGTH	=	0.045 MI.
BRIDGE #480051	ADT	2013	=	19,500	LENGTH	=	0.034 MI.	BRIDGE #480123	ADT	2013	=	25,250	LENGTH	=	0.025 MI.
BRIDGE #480054	ADT	2013	=	19,500	LENGTH	=	0.034 MI.	BRIDGE #480124	ADT	2013	=	26,500	LENGTH	=	0.025 MI.
BRIDGE #480065	ADT	2013	=	19,500	LENGTH	=	0.035 MI.								
BRIDGE #480066	ADT	2013	=	19,500	LENGTH	=	0.035 MI.								

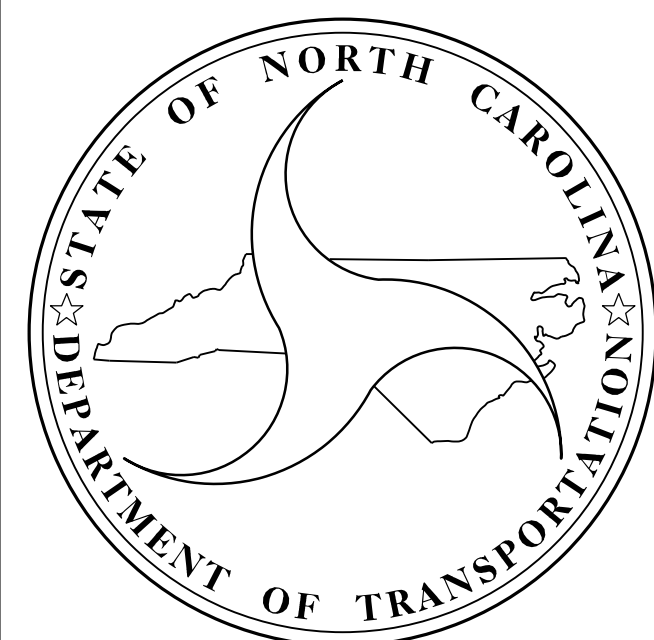

Prepared for the Office of:  
**DIVISION OF HIGHWAYS**  
 STRUCTURES MANAGEMENT UNIT  
 1000 BIRCH RIDGE DR.  
 RALEIGH, N.C. 27610

2018 STANDARD SPECIFICATIONS

LETTING DATE :

JUNE 21, 2022

**DIEGO A. AGUIRRE, PhD, PE**  
 PROJECT ENGINEER

**FIDEL L. FLORES, E.I.**  
 PROJECT DESIGN ENGINEER

STATE	STATE PROJECT REFERENCE NO.	SHEET NO.	TOTAL SHEETS
N.C.	I-5915B	1A	214
STATE PROJ. NO.	F. A. PROJ. NO.	DESCRIPTION	
45919.1.1	0040102	P.E.	
45919.3.3	0040102	CONST.	

# INDEX OF SHEETS

1 TITLE SHEET  
 1A INDEX OF SHEETS  
 S2 TOTAL BILL OF MATERIAL  
 S3 GENERAL DRAWING - BRIDGE LOCATION SKETCHES  
 S4 GENERAL NOTES

## 170171 (S1)

S1-1 GENERAL DRAWING 170171  
 S1-2 TYPICAL SECTION  
 S1-3 PLAN OF SPANS  
 S1-4 APPROACH ROADWAY  
 S1-5 SUBSTRUCTURE REPAIRS - END BENTS 1 AND 2  
 S1-6 SUBSTRUCTURE REPAIRS - BENT 1  
 S1-7 SUBSTRUCTURE REPAIRS - BENT 2

## 170172 (S2)

S2-1 GENERAL DRAWING 170172  
 S2-2 TYPICAL SECTION  
 S2-3 APPROACH ROADWAY  
 S2-4 SUBSTRUCTURE REPAIRS - END BENTS 1 AND 2  
 S2-5 SUBSTRUCTURE REPAIRS - BENT 1  
 S2-6 SUBSTRUCTURE REPAIRS - BENT 2

## 170177 (S3)

S3-1 GENERAL DRAWING 170177  
 S3-2 TYPICAL SECTION  
 S3-3 PLAN OF SPANS  
 S3-4 PLAN OF SPANS  
 S3-5 JOINT DETAILS  
 S3-6 APPROACH ROADWAY  
 S3-7 SUPERSTRUCTURE REPAIRS  
 S3-8 SUBSTRUCTURE REPAIRS - END BENTS 1 AND 2  
 S3-9 SUBSTRUCTURE REPAIRS - BENT 1  
 S3-10 SUBSTRUCTURE REPAIRS - BENT 2  
 S3-11 SUBSTRUCTURE REPAIRS - BENT 3

## 170178 (S4)

S4-1 GENERAL DRAWING 170178  
 S4-2 TYPICAL SECTION  
 S4-3 PLAN OF SPANS  
 S4-4 PLAN OF SPANS  
 S4-5 JOINT DETAILS  
 S4-6 APPROACH ROADWAY  
 S4-7 SUPERSTRUCTURE REPAIRS  
 S4-8 SUBSTRUCTURE REPAIRS - END BENTS 1 AND 2  
 S4-9 SUBSTRUCTURE REPAIRS - BENT 1  
 S4-10 SUBSTRUCTURE REPAIRS - BENT 2  
 S4-11 SUBSTRUCTURE REPAIRS - BENT 3

## 480006 (S5)

S5-1 GENERAL DRAWING 480006  
 S5-2 TYPICAL SECTION  
 S5-3 PLAN OF SPANS  
 S5-4 PLAN OF SPANS  
 S5-5 PLAN OF SPANS  
 S5-6 PLAN OF SPANS  
 S5-7 JOINT DETAILS  
 S5-8 APPROACH ROADWAY  
 S5-9 SUPERSTRUCTURE REPAIRS  
 S5-10 SUPERSTRUCTURE REPAIRS  
 S5-11 SUPERSTRUCTURE REPAIRS  
 S5-12 SUPERSTRUCTURE REPAIRS  
 S5-13 BEARING REPAIRS  
 S5-14 SUBSTRUCTURE REPAIRS - END BENTS 1 AND 2  
 S5-15 SUBSTRUCTURE REPAIRS - BENT 1  
 S5-16 SUBSTRUCTURE REPAIRS - BENT 2  
 S5-17 SUBSTRUCTURE REPAIRS - BENT 3  
 S5-18 SUBSTRUCTURE REPAIRS - BENT 4  
 S5-19 SUBSTRUCTURE REPAIRS - BENT 5  
 S5-20 SUBSTRUCTURE REPAIRS - BENT 6  
 S5-21 SUBSTRUCTURE REPAIRS - BENT 7  
 S5-22 SUBSTRUCTURE REPAIRS - BENT 8  
 S5-23 SUBSTRUCTURE REPAIRS - BENT 9  
 S5-24 SUBSTRUCTURE REPAIRS - BENT 10

## 480007 (S6)

S6-1 GENERAL DRAWING 480007  
 S6-2 TYPICAL SECTION  
 S6-3 PLAN OF SPANS  
 S6-4 PLAN OF SPANS  
 S6-5 PLAN OF SPANS  
 S6-6 PLAN OF SPANS  
 S6-7 JOINT DETAILS  
 S6-8 APPROACH ROADWAY  
 S6-9 SUPERSTRUCTURE REPAIRS  
 S6-10 SUPERSTRUCTURE REPAIRS  
 S6-11 SUPERSTRUCTURE REPAIRS  
 S6-12 SUPERSTRUCTURE REPAIRS  
 S6-13 BEARING REPAIRS  
 S6-14 SUBSTRUCTURE REPAIRS - END BENTS 1 AND 2  
 S6-15 SUBSTRUCTURE REPAIRS - BENT 1  
 S6-16 SUBSTRUCTURE REPAIRS - BENT 2  
 S6-17 SUBSTRUCTURE REPAIRS - BENT 3  
 S6-18 SUBSTRUCTURE REPAIRS - BENT 4  
 S6-19 SUBSTRUCTURE REPAIRS - BENT 5  
 S6-20 SUBSTRUCTURE REPAIRS - BENT 6  
 S6-21 SUBSTRUCTURE REPAIRS - BENT 7  
 S6-22 SUBSTRUCTURE REPAIRS - BENT 8  
 S6-23 SUBSTRUCTURE REPAIRS - BENT 9  
 S6-24 SUBSTRUCTURE REPAIRS - BENT 10

## 480051 (S7)

S7-1 GENERAL DRAWING 480051  
 S7-2 TYPICAL SECTION  
 S7-3 PLAN OF SPANS  
 S7-4 PLAN OF SPANS  
 S7-5 JOINT DETAILS  
 S7-6 APPROACH ROADWAY  
 S7-7 SUPERSTRUCTURE REPAIRS  
 S7-8 SUBSTRUCTURE REPAIRS - END BENTS 1 AND 2  
 S7-9 SUBSTRUCTURE REPAIRS - BENT 1  
 S7-10 SUBSTRUCTURE REPAIRS - BENT 2  
 S7-11 SUBSTRUCTURE REPAIRS - BENT 3  
 S7-12 EROSION REMEDIATION

## 480054 (S8)

S8-1 GENERAL DRAWING 480054  
 S8-2 TYPICAL SECTION  
 S8-3 PLAN OF SPANS  
 S8-4 PLAN OF SPANS  
 S8-5 JOINT DETAILS  
 S8-6 APPROACH ROADWAY  
 S8-7 SUPERSTRUCTURE REPAIRS  
 S8-8 SUBSTRUCTURE REPAIRS - END BENTS 1 AND 2  
 S8-9 SUBSTRUCTURE REPAIRS - BENT 1  
 S8-10 SUBSTRUCTURE REPAIRS - BENT 2  
 S8-11 SUBSTRUCTURE REPAIRS - BENT 3  
 S8-12 EROSION REMEDIATION

## 480065 (S9)

S9-1 GENERAL DRAWING 480065  
 S9-2 TYPICAL SECTION  
 S9-3 PLAN OF SPANS  
 S9-4 PLAN OF SPANS  
 S9-5 JOINT DETAILS  
 S9-6 APPROACH ROADWAY  
 S9-7 SUPERSTRUCTURE REPAIRS  
 S9-8 SUBSTRUCTURE REPAIRS - END BENTS 1 AND 2  
 S9-9 SUBSTRUCTURE REPAIRS - BENT 1  
 S9-10 SUBSTRUCTURE REPAIRS - BENT 2  
 S9-11 SUBSTRUCTURE REPAIRS - BENT 3  
 S9-12 EROSION REMEDIATION

## 480066 (S10)

S10-1 GENERAL DRAWING 480066  
 S10-2 TYPICAL SECTION  
 S10-3 PLAN OF SPANS  
 S10-4 PLAN OF SPANS  
 S10-5 JOINT DETAILS  
 S10-6 APPROACH ROADWAY  
 S10-7 SUPERSTRUCTURE REPAIRS  
 S10-8 SUBSTRUCTURE REPAIRS - END BENTS 1 AND 2  
 S10-9 SUBSTRUCTURE REPAIRS - BENT 1  
 S10-10 SUBSTRUCTURE REPAIRS - BENT 2  
 S10-11 SUBSTRUCTURE REPAIRS - BENT 3  
 S10-12 EROSION REMEDIATION

## 480072 (S11)

S11-1 GENERAL DRAWING 480072  
 S11-2 TYPICAL SECTION  
 S11-3 PLAN OF SPANS  
 S11-4 PLAN OF SPANS  
 S11-5 JOINT DETAILS  
 S11-6 APPROACH ROADWAY  
 S11-7 SUPERSTRUCTURE REPAIRS  
 S11-8 SUBSTRUCTURE REPAIRS - END BENTS 1 AND 2  
 S11-9 SUBSTRUCTURE REPAIRS - BENT 1  
 S11-10 SUBSTRUCTURE REPAIRS - BENT 2

## 480073 (S12)

S12-1 GENERAL DRAWING 480073  
 S12-2 TYPICAL SECTION  
 S12-3 PLAN OF SPANS  
 S12-4 PLAN OF SPANS  
 S12-5 JOINT DETAILS  
 S12-6 APPROACH ROADWAY  
 S12-7 SUPERSTRUCTURE REPAIRS  
 S12-8 SUBSTRUCTURE REPAIRS - END BENTS 1 AND 2  
 S12-9 SUBSTRUCTURE REPAIRS - BENT 1  
 S12-10 SUBSTRUCTURE REPAIRS - BENT 2

## 480096 (S13)

S13-1 GENERAL DRAWING 480096  
 S13-2 TYPICAL SECTION  
 S13-3 PLAN OF SPANS  
 S13-4 JOINT DETAILS  
 S13-5 APPROACH ROADWAY  
 S13-6 SUPERSTRUCTURE REPAIRS  
 S13-7 SUBSTRUCTURE REPAIRS - END BENTS 1 AND 2  
 S13-8 SUBSTRUCTURE REPAIRS - BENT 1  
 S13-9 SUBSTRUCTURE REPAIRS - BENT 2

## 480102 (S14)

S14-1 GENERAL DRAWING 480102  
 S14-2 TYPICAL SECTION  
 S14-3 PLAN OF SPANS  
 S14-4 JOINT DETAILS  
 S14-5 APPROACH ROADWAY  
 S14-6 SUPERSTRUCTURE REPAIRS  
 S14-7 SUBSTRUCTURE REPAIRS - END BENTS 1 AND 2  
 S14-8 SUBSTRUCTURE REPAIRS - BENT 1  
 S14-9 SUBSTRUCTURE REPAIRS - BENT 2

## 480104 (S15)

S15-1 GENERAL DRAWING 480104  
 S15-2 TYPICAL SECTION  
 S15-3 PLAN OF SPANS  
 S15-4 JOINT DETAILS  
 S15-5 SUPERSTRUCTURE REPAIRS  
 S15-6 SUBSTRUCTURE REPAIRS - END BENTS 1 AND 2  
 S15-7 SUBSTRUCTURE REPAIRS - BENT 1  
 S15-8 SUBSTRUCTURE REPAIRS - BENT 2  
 S15-9 SUBSTRUCTURE REPAIRS - BENT 3

## 480109 (S16)

S16-1 GENERAL DRAWING 480109  
 S16-2 TYPICAL SECTION  
 S16-3 PLAN OF SPANS  
 S16-4 JOINT DETAILS  
 S16-5 SUPERSTRUCTURE REPAIRS  
 S16-6 SUBSTRUCTURE REPAIRS - END BENTS 1 AND 2  
 S16-7 SUBSTRUCTURE REPAIRS - BENT 1  
 S16-8 SUBSTRUCTURE REPAIRS - BENT 2  
 S16-9 SUBSTRUCTURE REPAIRS - BENT 3

## 480123 (S17)

S17-1 GENERAL DRAWING 480123  
 S17-2 TYPICAL SECTION  
 S17-3 PLAN OF SPANS  
 S17-4 JOINT DETAILS  
 S17-5 SUPERSTRUCTURE REPAIRS  
 S17-6 SUBSTRUCTURE REPAIRS - END BENTS 1 AND 2  
 S17-7 SUBSTRUCTURE REPAIRS - BENT 1  
 S17-8 SUBSTRUCTURE REPAIRS - BENT 2

## 480124 (S18)

S18-1 GENERAL DRAWING 480124  
 S18-2 TYPICAL SECTION  
 S18-3 PLAN OF SPANS  
 S18-4 JOINT DETAILS  
 S18-5 SUPERSTRUCTURE REPAIRS  
 S18-6 SUBSTRUCTURE REPAIRS - END BENTS 1 AND 2  
 S18-7 SUBSTRUCTURE REPAIRS - BENT 1  
 S18-8 SUBSTRUCTURE REPAIRS - BENT 2

S5 DECK REPAIR DETAILS  
 S6 CONCRETE RESTORATION DETAILS  
 S7 CONCRETE RESTORATION DETAILS  
 S8 BRIDGE JACKING DETAILS  
 S9 MISCELLANEOUS DETAILS  
 STANDARD NOTES



# STRUCTURES

## TOTAL BILL OF MATERIAL

DESCRIPTION	BORROW EXCAVATION	INCIDENTAL MILLING	ASPHALT CONCRETE SURFACE COURSE, TYPES 9, 5C	ASPHALT BINDER FOR PLANT MIX	FLOWABLE FILL	GROOVING BRIDGE FLOORS	POLLUTION CONTROL	CLASS II, SURFACE PREPARATION	CLASS III, SURFACE PREPARATION	CONCRETE REPAIRS	SHOTCRETE REPAIRS	EPOXY RESIN INJECTION	ZONE PAINTING OF EXISTING STRUCTURE	PAINTING CONTAINMENT FOR BRIDGE *	PAINTING CONTAINMENT FOR ZONE PAINTING
BRIDGE NO.	CU. YD.	SQ. YD.	TON	TON	CU. YD.	SQ. FT.	LUMP SUM	SQ. YD.	SQ. YD.	CU. FT.	CU. FT.	LIN. FT.	LUMP SUM	LUMP SUM	LUMP SUM
170171	-	490	41	2.5	-	-	-	0.1	-	2	8.6	135	-	-	-
170172	-	490	41	2.5	-	-	-	-	-	5.9	4.1	104.7	-	-	-
170177	-	1402	261	15.9	-	-	LUMP SUM	39.2	0	41.3	20.8	10.1	-	LUMP SUM	-
170178	-	1377	257	15.6	-	-	LUMP SUM	82.2	0.8	4.5	9.1	31	-	LUMP SUM	-
480006	-	1565	641	39.1	-	-	LUMP SUM	0	0	0.9	19.9	24	LUMP SUM	LUMP SUM	LUMP SUM
480007	-	1529	603	36.8	-	-	LUMP SUM	12.7	0	5.7	36	12.5	LUMP SUM	LUMP SUM	LUMP SUM
480051	4.1	1538	280	17	1.9	-	LUMP SUM	8.6	5.8	25.2	17.5	9.5	LUMP SUM	LUMP SUM	LUMP SUM
480054	2.4	1498	274	16.6	1.1	-	LUMP SUM	3.1	4.5	7.1	43.8	9	LUMP SUM	LUMP SUM	LUMP SUM
480065	8.5	1545	284	17.2	4.9	-	LUMP SUM	1.7	3	2.2	9.6	10.3	LUMP SUM	LUMP SUM	LUMP SUM
480066	8.5	1518	280	16.9	4.5	-	LUMP SUM	0.1	15.1	6.2	42.1	28.5	LUMP SUM	LUMP SUM	LUMP SUM
480072	-	311	26	1.6	-	3360	LUMP SUM	18	38.3	3.4	55.6	21	LUMP SUM	LUMP SUM	LUMP SUM
480073	-	331	28	1.7	-	3360	LUMP SUM	10.7	77.2	21.5	46.7	12	LUMP SUM	LUMP SUM	LUMP SUM
480096	-	314	27	1.6	-	-	LUMP SUM	0	0	0.7	20.5	13	LUMP SUM	LUMP SUM	LUMP SUM
480102	-	318	27	1.6	-	-	LUMP SUM	3.6	12.9	7.6	15.3	0	LUMP SUM	LUMP SUM	LUMP SUM
480104	-	-	-	-	-	-	LUMP SUM	0	0	17.1	32.1	151	-	LUMP SUM	-
480109	-	-	-	-	-	-	LUMP SUM	3.9	0	0	5.5	1	-	LUMP SUM	-
480123	-	-	-	-	-	-	-	0	4.5	21.1	13.6	4.2	-	-	-
480124	-	-	-	-	-	-	-	0	0	26.4	8.8	31	-	-	-
TOTALS	23.5	14226	3070	186.6	12.4	6720	LUMP SUM	183.9	162.1	198.8	409.6	607.8	LUMP SUM	LUMP SUM	LUMP SUM

NOTES:

- THE ROADWAY PAY ITEMS LISTED HEREIN COINCIDE WITH THE BRIDGE PRESERVATION WORK ONLY. FOR COMPLETE LIST OF ROADWAY PAY ITEMS, NOTES AND PROVISIONS, SEE ROADWAY PLANS.

# STRUCTURES

## TOTAL BILL OF MATERIAL - CONT.

DESCRIPTION	VOLUMETRIC MIXER	UNCLASSIFIED STRUCTURE EXCAVATION AT BRIDGE *	ASPHALT JOINT REPAIR/REPLACEMENT	FOAM JOINT SEALS FOR PRESERVATION	ELASTOMERIC CONCRETE FOR PRESERVATION	BRIDGE JOINT DEMOLITION	HYDRO-DEMOLITION OF BRIDGE DECK	LATEX MODIFIED CONCRETE OVERLAY- VERY EARLY STRENGTH	PLACING AND FINISHING LATEX MODIFIED CONCRETE OVERLAY- VERY EARLY STRENGTH	SCARIFYING BRIDGE DECK	SHOTBLASTING BRIDGE DECK	SILANE DECK TREATMENT	BEARING REPAIRS	CLEANING AND PAINTING EXISTING BEARINGS WITH HRSCA	TYPE I BRIDGE JACKING FOR BRIDGE *
BRIDGE NO.	LUMP SUM	LUMP SUM	LIN. FT.	LIN. FT.	CU. FT.	SQ. FT.	SQ. YD.	CU. YD.	SQ. YD.	SQ. YD.	SQ. YD.	SQ. YD.	EA	EA	EA
170171	LUMP SUM	-	-	-	-	-	-	-	-	-	-	-	-	-	2
170172	LUMP SUM	-	-	-	-	-	-	-	-	-	-	-	-	-	3
170177	LUMP SUM	-	156.4	-	-	-	-	-	-	-	560	560	-	24	-
170178	LUMP SUM	-	156.4	-	-	-	-	-	-	-	-	-	-	24	-
480006	LUMP SUM	-	101.5	101.5	-	-	-	-	-	-	2841	2841	1	20	1
480007	LUMP SUM	-	101.5	101.5	-	-	-	-	-	-	2834	2834	7	20	7
480051	LUMP SUM	LUMP SUM	169.2	-	-	-	-	-	-	560	-	-	-	24	-
480054	LUMP SUM	LUMP SUM	169.2	-	-	-	-	-	-	560	-	-	-	24	-
480065	LUMP SUM	LUMP SUM	188.7	-	-	-	-	-	-	576	-	-	-	24	-
480066	LUMP SUM	LUMP SUM	188.7	-	-	-	-	-	-	576	-	-	-	24	1
480072	LUMP SUM	-	-	128	30.4	121.3	375	21	375	375	-	-	-	16	-
480073	LUMP SUM	-	-	128	30.4	121.3	375	21	375	375	-	-	-	16	-
480096	LUMP SUM	-	-	118	35.2	140	-	-	-	-	-	-	-	16	-
480102	LUMP SUM	-	-	118	32.8	130.7	-	-	-	-	561	561	-	16	-
480104	LUMP SUM	-	-	202	49	194.1	-	-	-	-	-	-	-	24	-
480109	LUMP SUM	-	-	286	70	278.4	-	-	-	-	-	-	-	36	-
480123	LUMP SUM	-	-	184	44.8	177.6	-	-	-	-	-	-	-	-	4
480124	LUMP SUM	-	-	131	31.2	124.4	-	-	-	-	-	-	-	-	-
TOTALS	LUMP SUM	LUMP SUM	1231.6	1498	323.8	1287.8	750	42	750	3022	6796	6796	8	308	18

BRIDGES: 170171, 170172, 170177, 170178  
 480006, 480007, 480051, 480054  
 480065, 480066, 480072, 480073  
 480096, 480102, 480104, 480109  
 480123, 480124

PROJECT NO. I-5915B  
 CATAWBA/IREDELL COUNTY  
 BRIDGE NO. MULTIPLE



STATE OF NORTH CAROLINA  
 DEPARTMENT OF TRANSPORTATION  
 RALEIGH

### TOTAL BILL OF MATERIAL

REVISIONS						SHEET NO.
NO.	BY:	DATE:	NO.	BY:	DATE:	TOTAL SHEETS
1			3			9
2			4			

DRAWN BY : DIEGO A. AGUIRRE DATE : 01/2022  
 CHECKED BY : JACOB H. DUKE DATE : 01/2022  
 DESIGN ENGINEER OF RECORD: DIEGO A. AGUIRRE DATE : 01/2022

DOCUMENT NOT CONSIDERED FINAL UNLESS ALL SIGNATURES COMPLETED



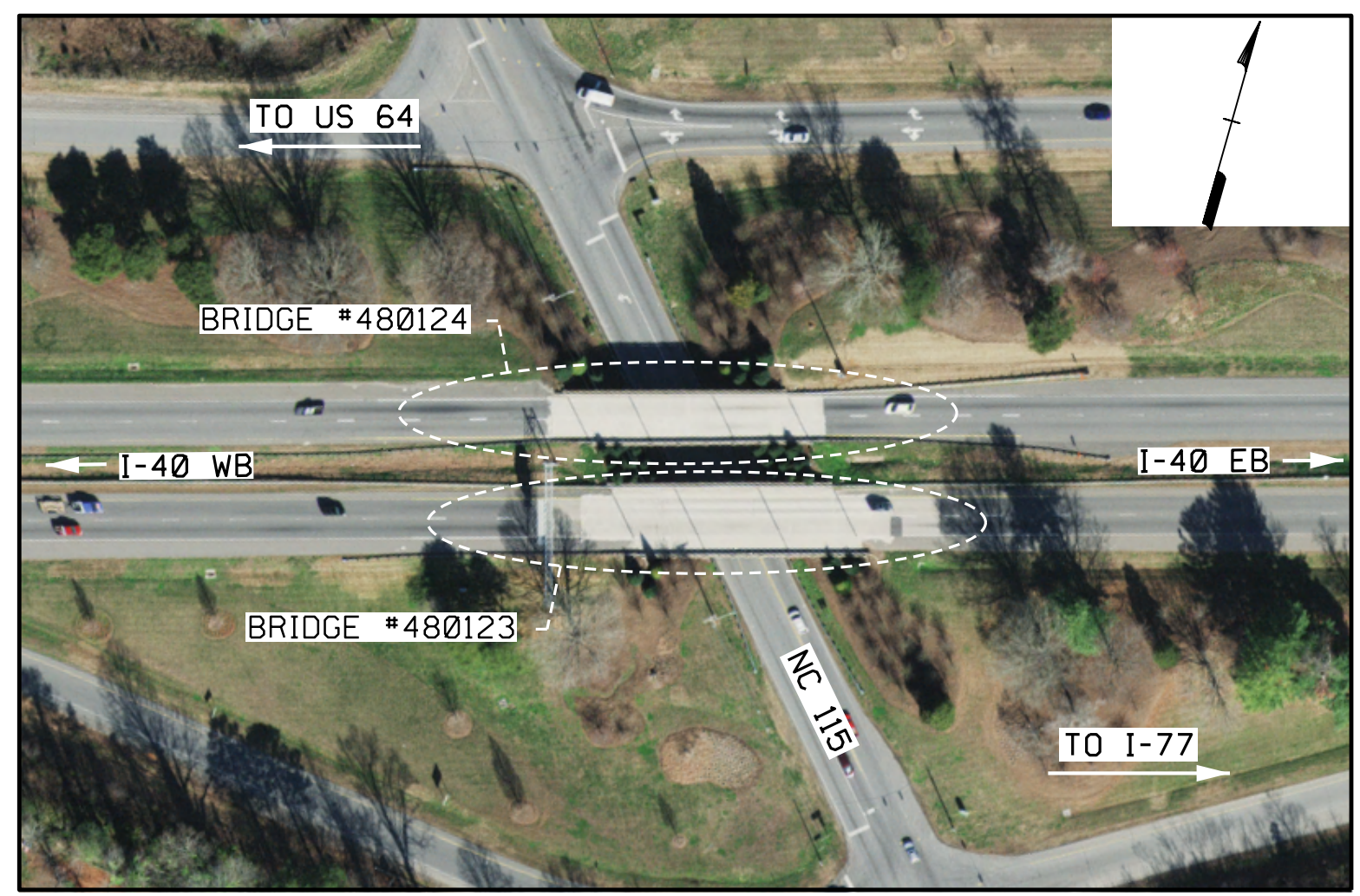
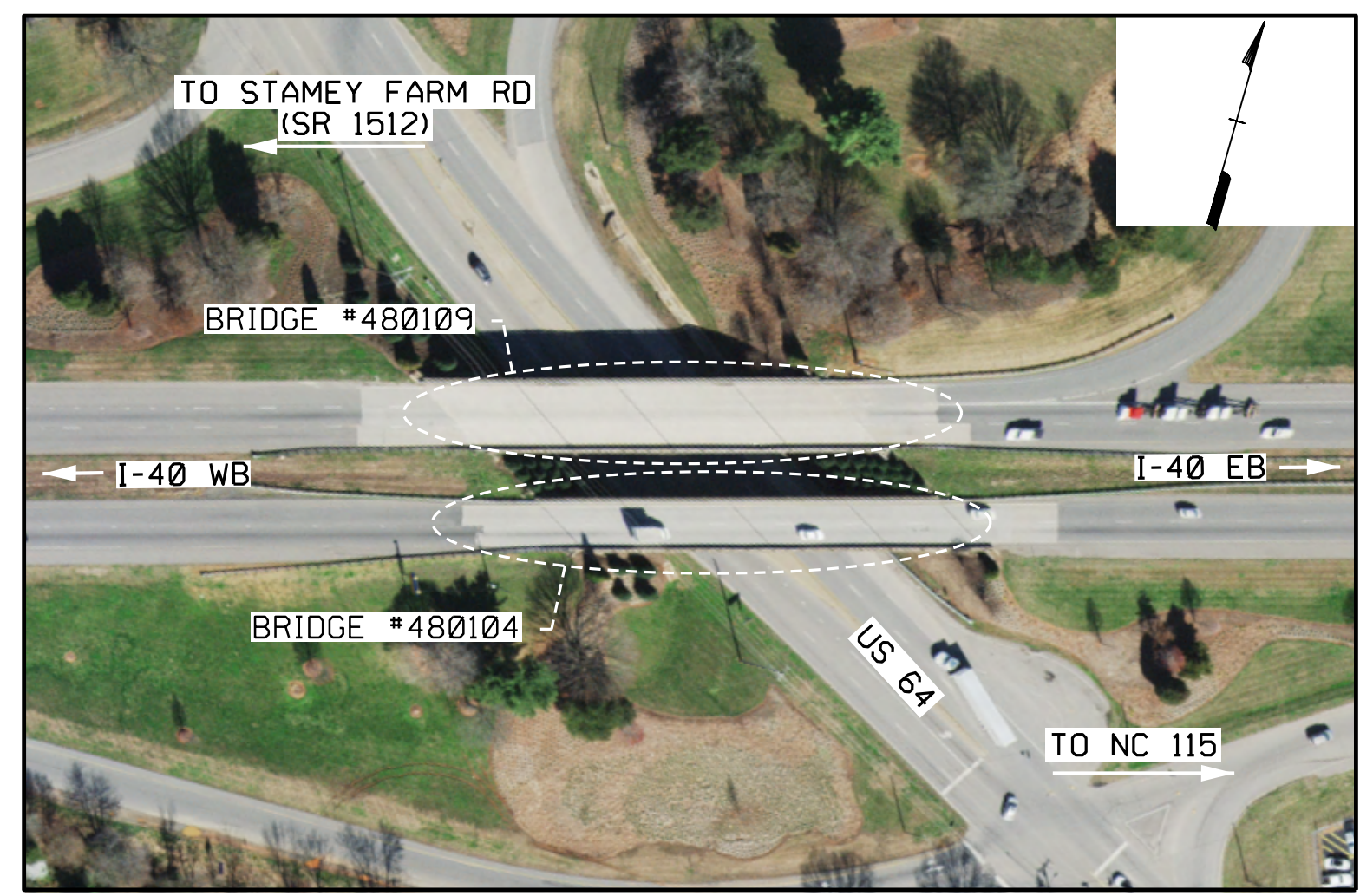
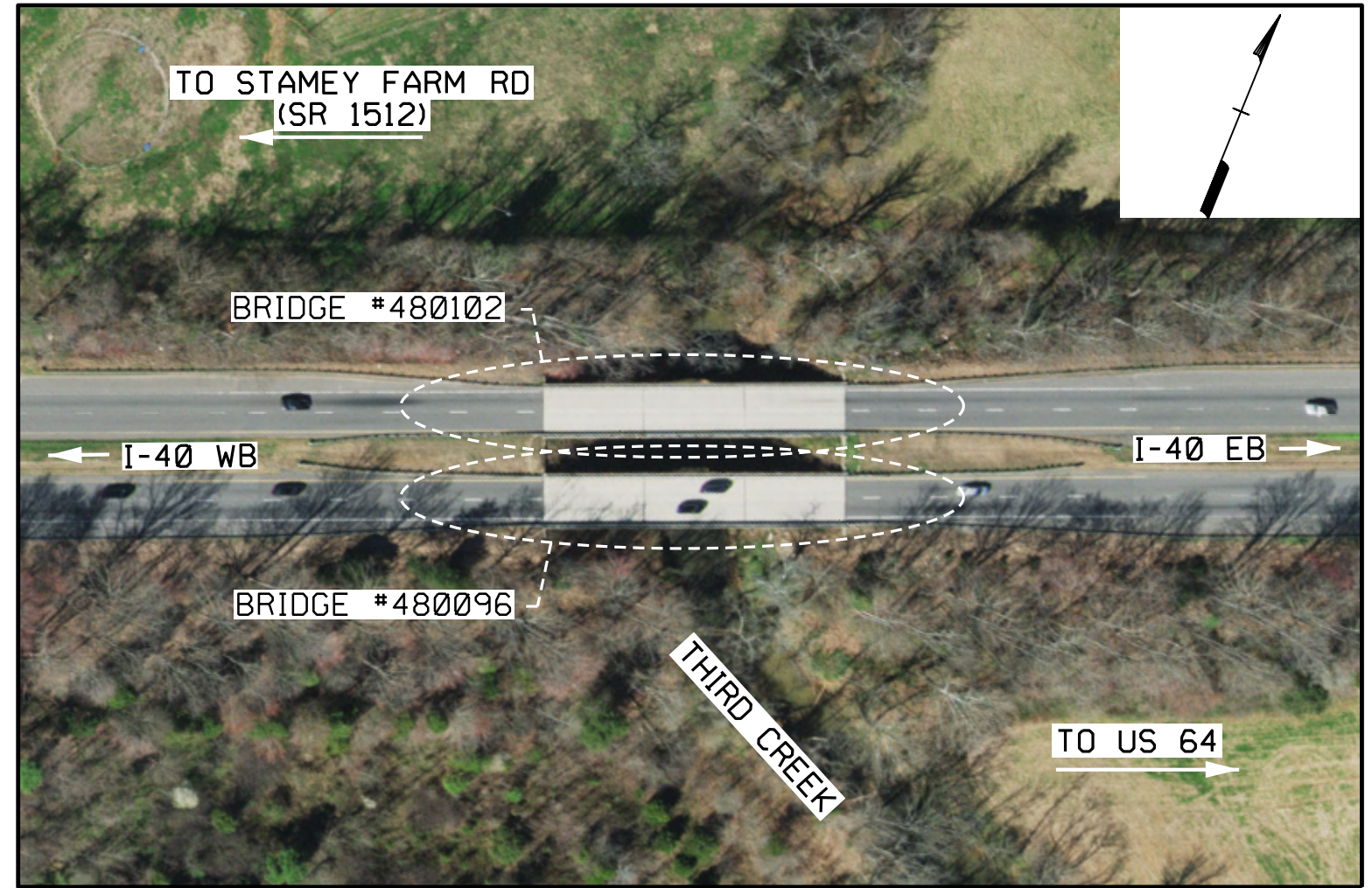
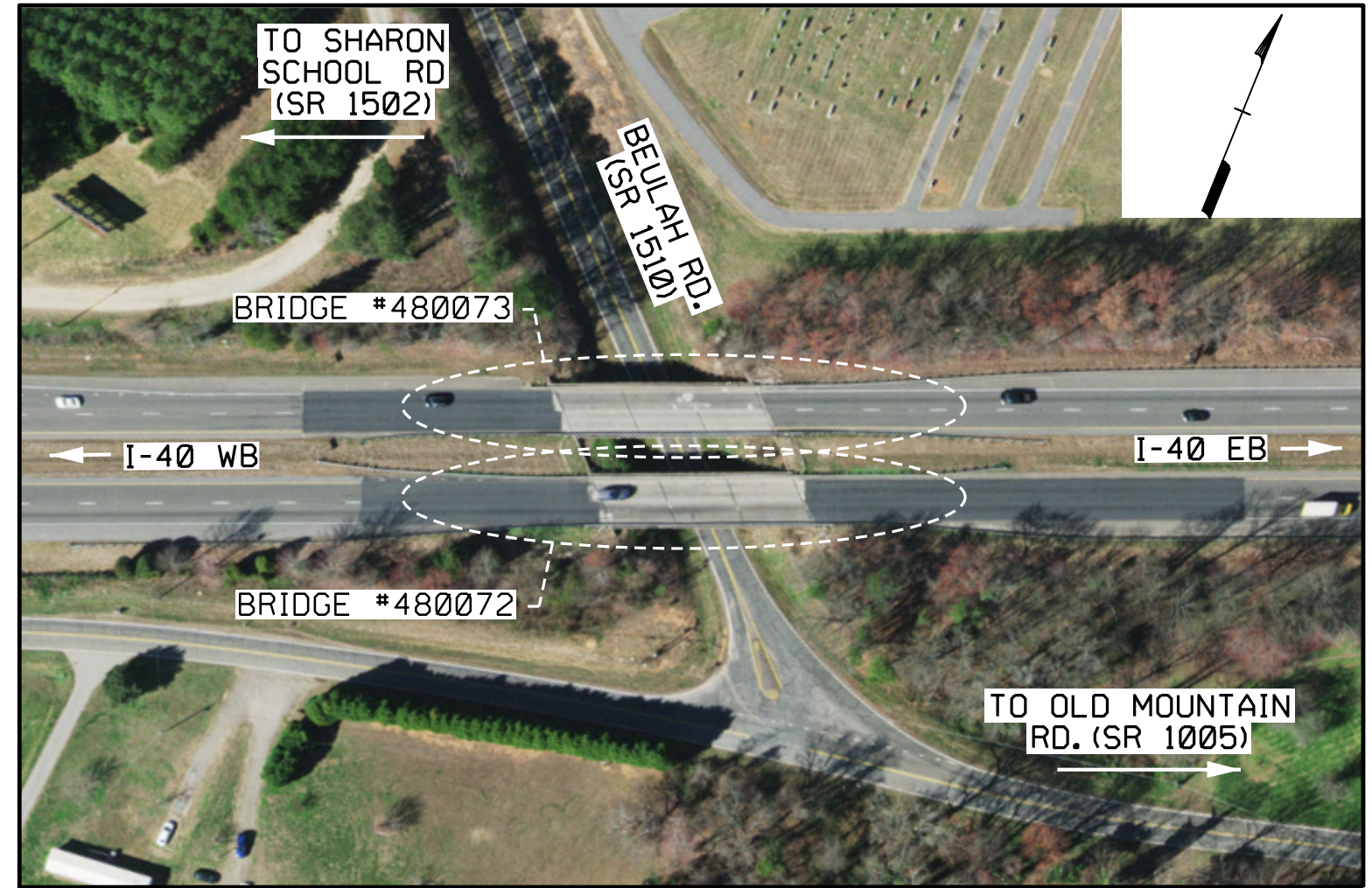
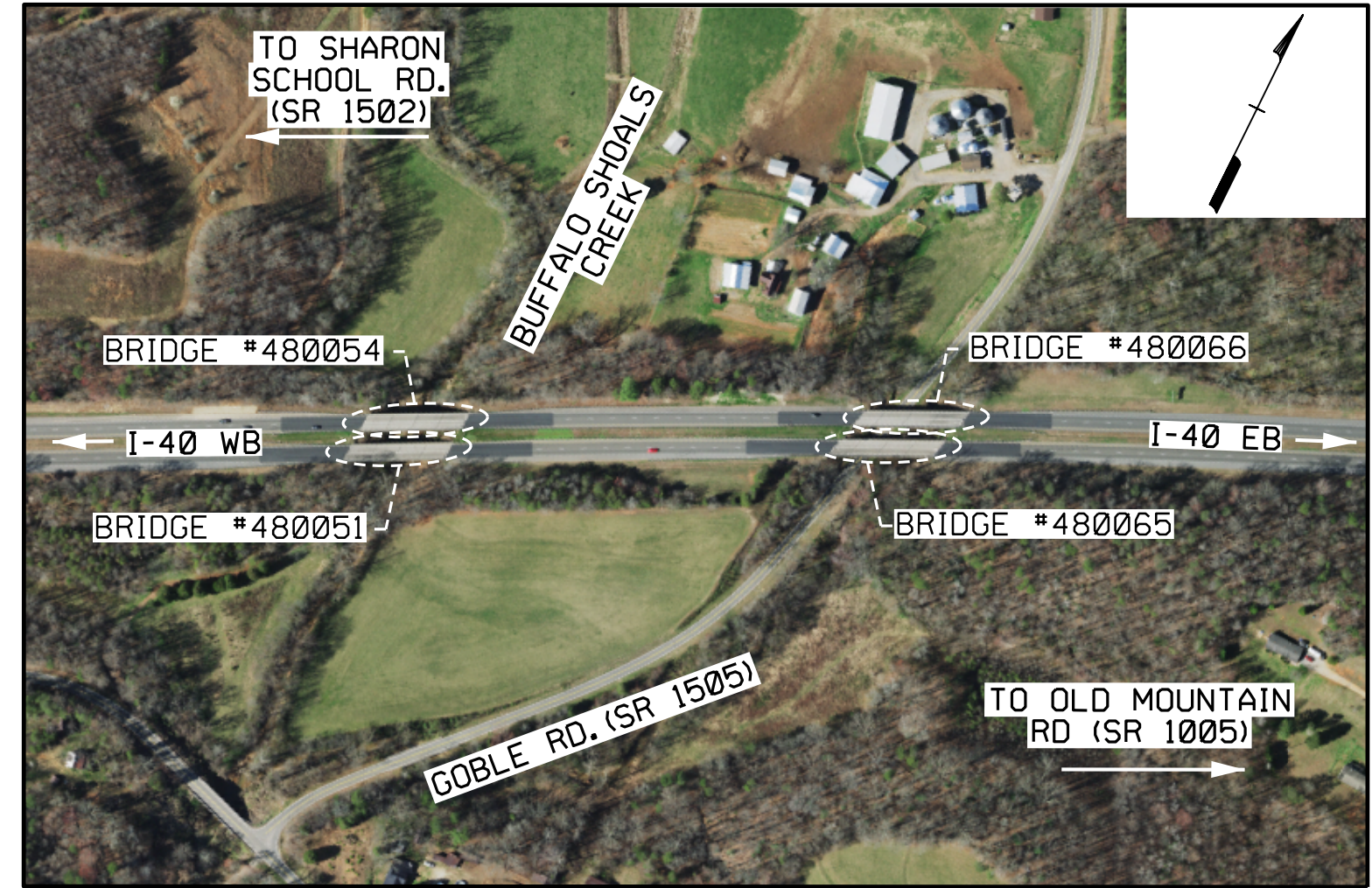
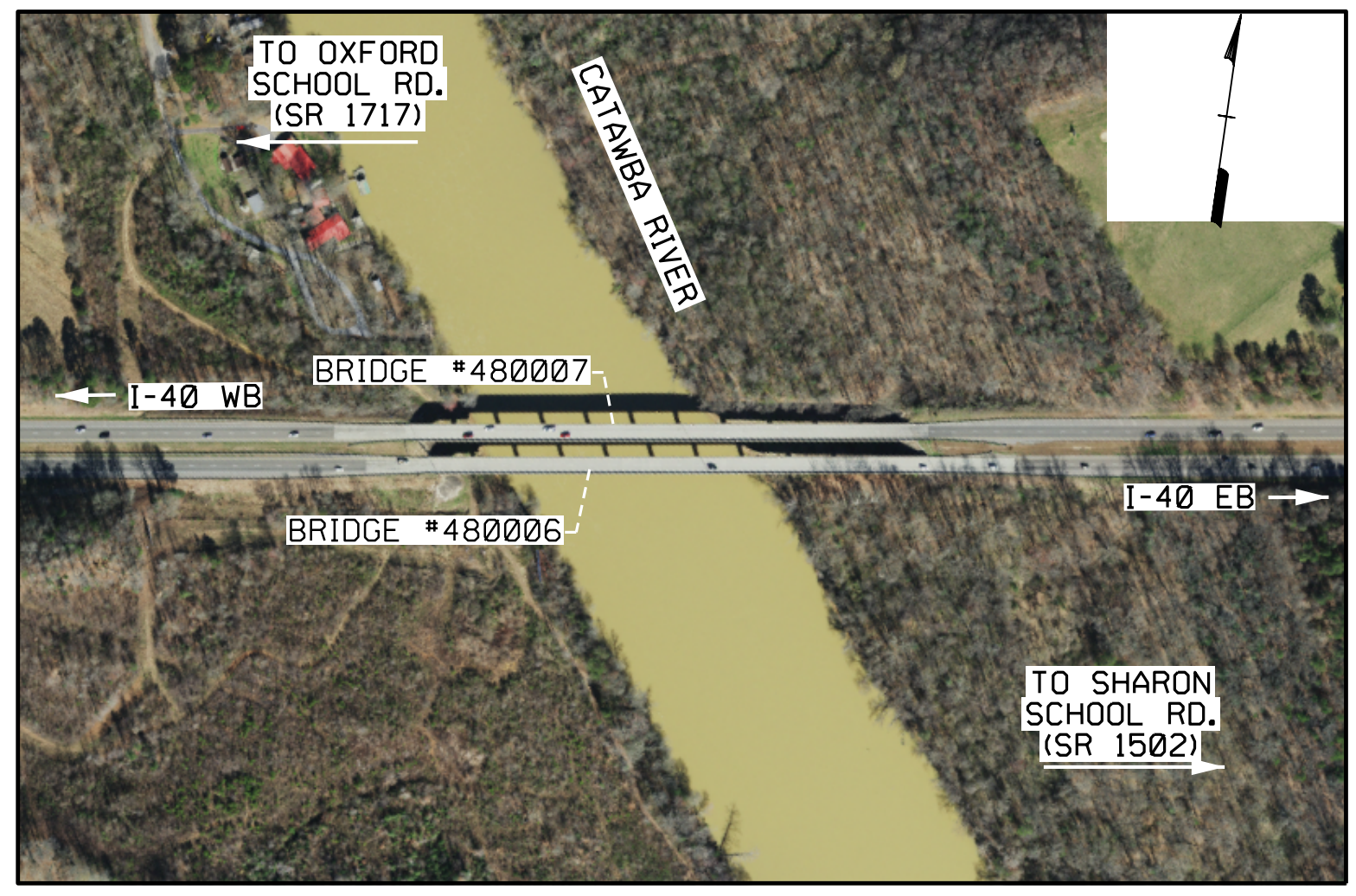
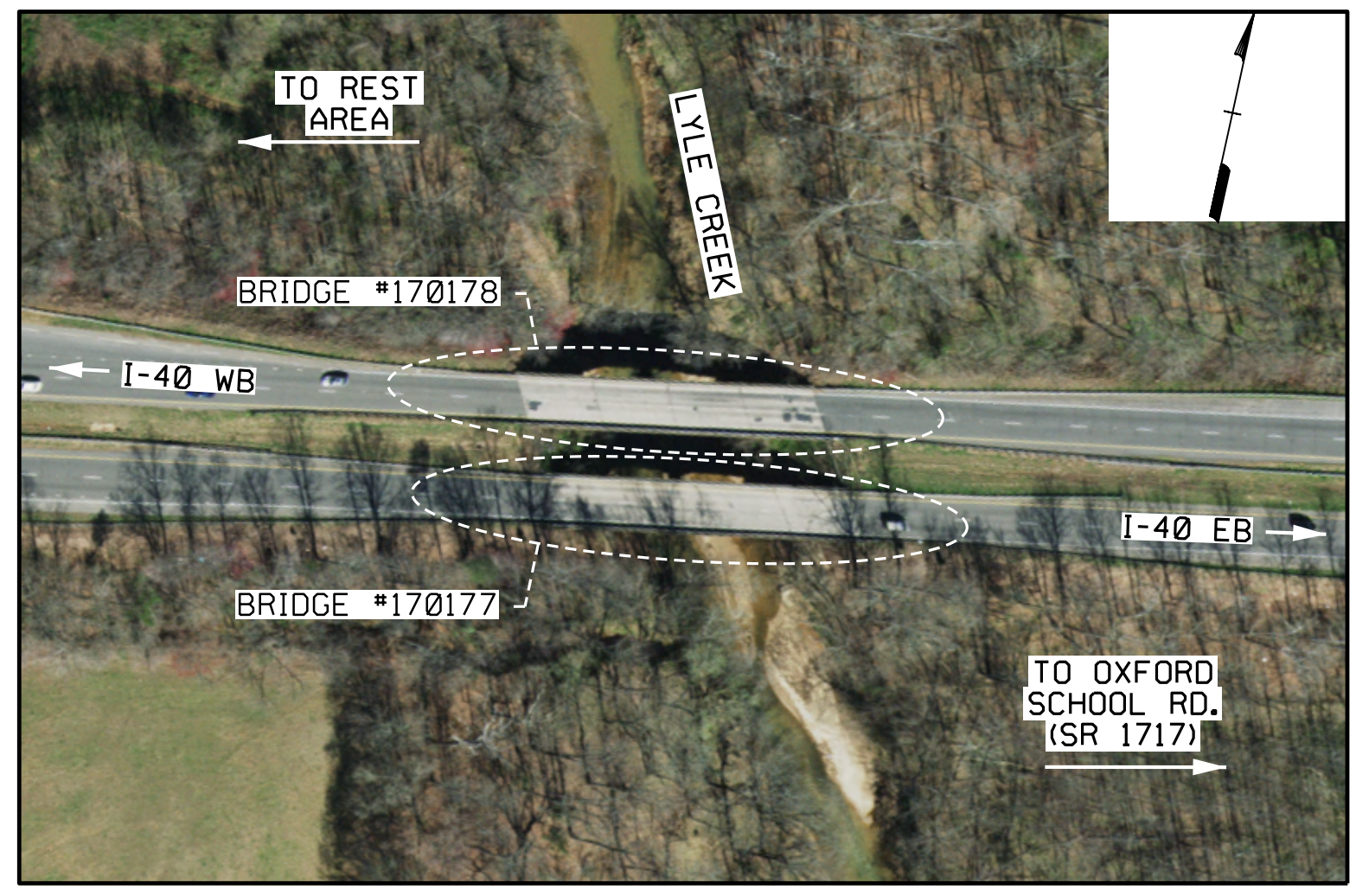
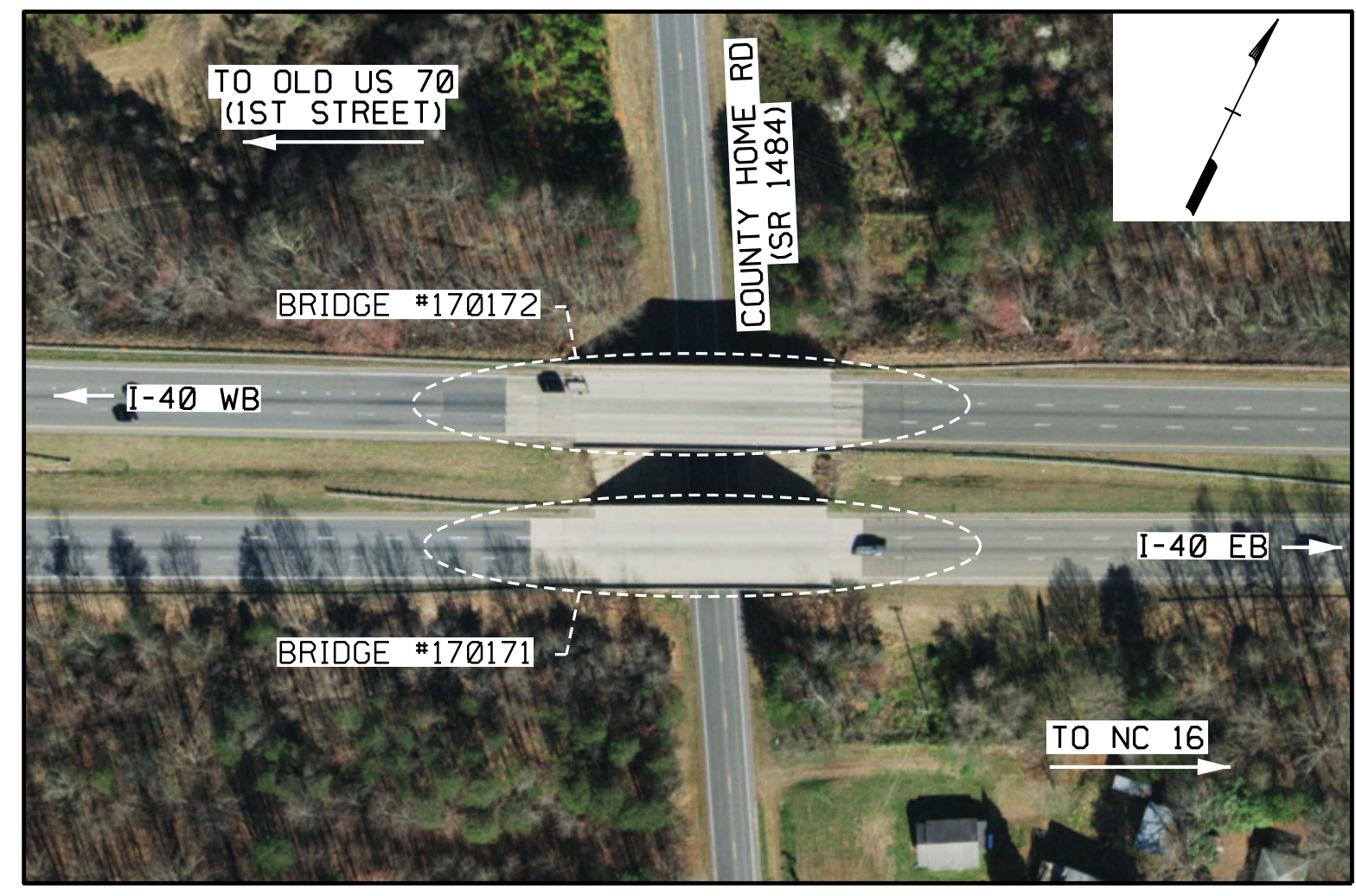

BRIDGES: 170171, 170172, 170177, 170178  
 480006, 480007, 480051, 480054  
 480065, 480066, 480072, 480073  
 480096, 480102, 480104, 480109  
 480123, 480124

PROJECT NO. I-5915B  
 CATAWBA/IREDELL COUNTY  
 BRIDGE NO. MULTIPLE



**KCA**  
**KISINGER CAMPO & ASSOCIATES**  
 301 FAYETTEVILLE ST., SUITE 1500  
 RALEIGH, NC 27601 (919) 882-7839  
 NC FIRM LICENSE: C-1506

STATE OF NORTH CAROLINA DEPARTMENT OF TRANSPORTATION RALEIGH					
GENERAL DRAWING BRIDGE LOCATION SKETCHES					
REVISIONS					
NO.	BY:	DATE:	NO.	BY:	DATE:
1			3		
2			4		
					SHEET NO. S3
					TOTAL SHEETS 9

LOCATION SKETCHES

INFORMATION INDICATED ON THE LOCATION SKETCH SHALL BE CONSIDERED GENERAL INFORMATION ONLY. THE CONTRACTOR SHALL CONFIRM, THROUGH OTHER SOURCES, SPECIFIC INFORMATION REGARDING BRIDGES, ROADWAYS, UTILITIES, THE SURROUNDING AREA, AND ANY OTHER ASPECTS THAT MAY BE NECESSARY TO PERFORM AND COMPLETE THE PROJECT.

DRAWN BY : DIEGO A. AGUIRRE DATE : 01/2022  
 CHECKED BY : JACOB H. DUKE DATE : 01/2022  
 DESIGN ENGINEER OF RECORD: DIEGO A. AGUIRRE DATE : 01/2022

DOCUMENT NOT CONSIDERED  
 FINAL UNLESS ALL  
 SIGNATURES COMPLETED



# GENERAL NOTES

ASSUMED LIVE LOAD FOR REPAIRS = HL93

GENERAL DRAWING INFORMATION IS TAKEN FROM THE ORIGINAL PLANS AND THE MOST UP TO DATE ROUTINE INSPECTION REPORTS.

BRIDGE ORIENTATION CONFORMS TO THE EXISTING BRIDGE PLANS/ ROUTINE INSPECTION.

THE CONTRACTOR'S ATTENTION IS CALLED TO THE FACT THAT DUE TO THE NATURE OF THE PRESERVATION PROJECTS, THE EXTENT OF WORK CANNOT ALWAYS BE ACCURATELY DETERMINED PRIOR TO COMMENCEMENT OF WORK. REPAIR LOCATIONS AND ESTIMATES OF QUANTITIES ARE GIVEN WITH THE BEST INFORMATION AVAILABLE. IF ADDITIONAL REPAIRS NOT SHOWN ON THE DRAWINGS ARE DEEMED NECESSARY BY THE ENGINEER, THE ENGINEER SHALL NOTE ON THE DRAWINGS THE APPROXIMATE LOCATION AND DESCRIPTION OF THE REPAIRS.

THE EXISTING DIMENSIONS AND BRIDGE CONDITION ARE FROM THE BEST INFORMATION AVAILABLE. THE CONTRACTOR SHALL FIELD VERIFY THE INFORMATION SHOWN ON THE PLANS AND NOTIFY THE ENGINEER IF ACTUAL DIMENSIONS AND CONDITIONS DIFFER.

THE CONTRACTOR SHALL HAVE NO CLAIM WHATSOEVER AGAINST THE DEPARTMENT FOR ANY DELAYS OF ADDITIONAL COST INCURRED BASED ON DIFFERENCES BETWEEN WHAT IS SHOWN ON THE PLANS AND THE ACTUAL CONDITIONS AT THE PROJECT SITE.

IT IS THE CONTRACTOR'S RESPONSIBILITY TO FOLLOW ALL STATE AND FEDERAL SAFETY REQUIREMENTS.

WORK ON THE BRIDGE(S) SHALL BE PERFORMED SO AS NOT TO ALLOW DEBRIS TO FALL BELOW, EXCEPT WHERE THE CONTRACTOR'S PLANS USE PLATFORMS, NETS, SCREENS OR OTHER PROTECTIVE DEVICES TO CATCH THE MATERIAL. THE CONTRACTOR SHALL SUBMIT PLANS FOR CONSTRUCTION IN ACCORDANCE WITH ARTICLE 402-2 OF THE STANDARD SPECIFICATIONS.

THE CONTRACTOR SHALL PERFORM ALL WORK WITH CARE SO THAT THE EXISTING STRUCTURE WHICH IS TO REMAIN IN PLACE WILL NOT BE DAMAGED. IF THE CONTRACTOR DAMAGES ANY PART OF THE EXISTING STRUCTURE WHICH IS TO REMAIN IN PLACE, THE DAMAGED AREA SHALL BE REPAIRED AND REPLACED IN A MANNER SATISFACTORY TO THE ENGINEER AT NO ADDITIONAL COST TO THE DEPARTMENT.

ANY DAMAGE TO EXISTING REINFORCING STEEL DURING CONTRACTOR'S OPERATIONS SHALL BE REPAIRED AS DIRECTED BY THE ENGINEER AND PERFORMED AT NO ADDITIONAL COST TO THE DEPARTMENT.

FOR CONTROL OF TRAFFIC AND LIMITS ON PHASING OF CONSTRUCTION, SEE TRANSPORTATION MANAGEMENT PLANS.

PRIOR TO BEGINNING WORK, THE CONTRACTOR SHALL SUBMIT FOR REVIEW AND APPROVAL A COMPLETE SEQUENCE OF TASKS FOR EACH OPERATION AFFECTING THE BRIDGE SURFACE AND/OR TRAFFIC.

FOR OTHER DESIGN DATA AND GENERAL NOTES, SEE SHEET SN.

REMOVING VEGETATION AND DEBRIS TO IMPROVE DRAINAGE FROM THE BRIDGE CORNERS, AND/OR TO CLEAR THE SUBSTRUCTURE OR SLOPES, SHALL BE CONSIDERED INCIDENTAL TO THE VARIOUS PAY ITEMS FOR THIS PROJECT. THE ENGINEER SHALL DIRECT VEGETATION REMOVAL AND NOTE ON THE DRAWINGS THE APPROXIMATE LOCATION AND DESCRIPTION OF THE REPAIRS.

ALL PAVEMENT MARKINGS WILL BE IN ACCORDANCE WITH THESE PLANS.

EXISTING JOINTS AND DECK DRAINS SHALL BE SEALED PRIOR TO BEGINNING SURFACE PREPARATIONS OF THE BRIDGE. THE CONTRACTOR SHALL TAKE CARE THAT ANY CONSTRUCTION DEBRIS THAT COLLECTS IN THE DRAINS IS CONTAINED. DRAINS IN SHOULDERS OF ADJACENT TRAVEL LANE(S) SHALL BE KEPT FREE AND CLEAR OF DEBRIS.

FOR ANY BRIDGE(S) WHERE AN ASPHALT WEARING SURFACE (AWS) OVERLAY IS TO BE PLACED OVER THE EXISTING DECK SURFACE, THE CONTRACTOR SHALL TAKE CARE THAT THE DECK DRAINS ARE NOT BLOCKED OUT WITH ASPHALT.

LONGITUDINAL CONSTRUCTION JOINTS OF OVERLAYS SHALL BE LOCATED ALONG THE CENTERLINE OR EDGE OF TRAVEL LANES.

INFORMATION INDICATED ON THE LOCATION SKETCH SHALL BE CONSIDERED GENERAL INFORMATION ONLY. THE CONTRACTOR SHALL CONFIRM SKETCHES THROUGH OTHER SOURCES, SPECIFIC INFORMATION REGARDING BRIDGES, ROADWAYS, UTILITIES, THE SURROUNDING AREA, AND ANY OTHER ASPECTS THAT MAY BE NECESSARY TO PERFORM AND COMPLETE THE PROJECT.

FOR PAINTING CONTAINMENT AND POLLUTION CONTROL, SEE CLEANING AND PAINTING EXISTING EXISTING BEARINGS WITH HRCSA SPECIAL PROVISION.

FOR PAINTING CONTAINMENT FOR ZONE PAINTING AND POLLUTION CONTROL, SEE ZONE PAINTING OF EXISTING STRUCTURE SPECIAL PROVISION.

FOR SUBMITTAL OF WORKING DRAWINGS, FALSEWORK AND FORMWORK, SEE SPECIAL PROVISIONS.

FOR CRANE SAFETY, SEE SPECIAL PROVISIONS.

FOR FALSEWORK AND FORMWORK, SEE SPECIAL PROVISIONS.

FOR GROUT FOR STRUCTURES, SEE SPECIAL PROVISIONS.

FOR VOLUMETRIC MIXER, SEE SPECIAL PROVISIONS.

FOR FOAM JOINT SEALS FOR PRESERVATION, SEE SPECIAL PROVISIONS.

FOR ELASTOMERIC CONCRETE FOR PRESERVATION, SEE SPECIAL PROVISIONS.

FOR BRIDGE JOINT DEMOLITION, SEE SPECIAL PROVISIONS.

FOR SCARIFYING BRIDGE DECKS, HYDRODEMOLITION OF BRIDGE DECKS AND PLACING AND FINISHING LATEX MODIFIED CONCRETE OVERLAYS - VERY EARLY STRENGTH, SEE SPECIAL PROVISIONS.

FOR SHOTBLASTING BRIDGE DECKS AND SILANE DECK TREATMENTS, SEE SPECIAL PROVISIONS.

FOR CLEANING AND PAINTING EXISTING BEARINGS WITH HRCSA, SEE SPECIAL PROVISIONS.

FOR ZONE PAINTING OF EXISTING STRUCTURE, SEE SPECIAL PROVISIONS.

FOR TYPE I BRIDGE JACKING, SEE SPECIAL PROVISIONS.

IN AS MUCH AS THE PAINT SYSTEM ON THE THE EXISTING STRUCTURAL STEEL CONTAINS LEAD, THE CONTRACTORS ATTENTION IS DIRECTED TO ARTICLE 107-1 OF THE STANDARD SPECIFICATIONS. ANY COSTS RESULTING FROM COMPLIANCE WITH APPLICABLE STATE OR FEDERAL REGULATIONS PERTAINING TO HANDLING OF MATERIALS CONTAINING LEAD BASED PAINT SHALL BE INCLUDED IN THE BID PRICE FOR ITEMS ASSOCIATED WITH THE CLEANING AND REPAINTING OF THE FOLLOWING BRIDGES:

- 170171
- 170172
- 480006
- 480007
- 480051
- 480054
- 480065
- 480066
- 480072
- 480073
- 480096
- 480102
- 480104
- 480109
- 480123

THE CONTRACTOR SHALL SCHEDULE CLEANING AND REPAINTING OPERATIONS SUCH THAT THE STEEL REPAIR IS PERFORMED AFTER THE STEEL HAS BEEN CLEANED AND PRIMED. AFTER STEEL REPAIRS HAVE BEEN COMPLETED, THE REPAIR AREAS AND THE REMAINING STEEL SHALL BE PROPERLY PREPARED AND PAINTED ACCORDING TO THE SPECIAL PROVISIONS.

THE CONTRACTOR SHALL PROVIDE INDEPENDENT ASSURANCE SAMPLES OF REINFORCING STEEL AS FOLLOWS: FOR PROJECTS REQUIRING UP TO 400 TONS OF REINFORCING STEEL, ONE 30 INCH SAMPLE OF EACH SIZE BAR USED, AND FOR PROJECTS REQUIRING OVER 400 TONS OF REINFORCING STEEL, TWO 30 INCH SAMPLES OF EACH SIZE BAR USED. THE SAMPLE BARS SHOULD COME FROM STEEL ACTUALLY USED IN THE PROJECT AND THE SAMPLE BARS SHOULD BE REPLACED BY SPLICED BARS AS SPECIFIED IN THE SAMPLE BAR REPLACEMENT CHART. PAYMENT FOR THE SAMPLE BARS AND REPLACEMENT REINFORCING STEEL SHALL BE CONSIDERED INCIDENTAL TO VARIOUS PAY ITEMS.

THE CONTRACTOR'S ATTENTION IS CALLED TO THE FACT THAT REINFORCING STEEL BARS MAY HAVE BEEN REMOVED IN PRIOR DECK REPAIRS, PARTICULARLY IN FULL DEPTH DECK REPAIRS. THESE REPAIRS CAN BE IDENTIFIED BY FORMWORK THAT HAS BEEN LEFT IN PLACE UNDER THE DECK. THE CONTRACTOR SHALL FIELD VERIFY SUCH PRIOR REPAIRS, THAT ARE NOT ALREADY SHOWN IN THESE PLANS, AND NOTIFY THE ENGINEER. THE CONTRACTOR SHALL PERFORM REPAIRS AS SHOWN IN THE "DECK REPAIR DETAILS" SHEET, AND AS DESCRIBED IN THE "OVERLAY SURFACE PREPARATION" SPECIAL PROVISIONS. MISSING REINFORCING STEEL THAT IS DETERMINED BY THE ENGINEER TO BE SUPPLIED, SHALL BE PROVIDED IN KIND TO A POINT WHERE EXISTING REINFORCING STEEL IS FOUND AND IT IS SOUND, THIS MAY REQUIRE EXTENSION OF PRIOR REPAIRS. UNSOUND REINFORCING STEEL THAT IS DETERMINED BY THE ENGINEER TO BE REPLACED, SHALL BE REMOVED TO A POINT WHERE IT IS SOUND. THE PATCH SHALL EXTEND A SUFFICIENT DISTANCE BEYOND THIS POINT TO DEVELOP A SPLICED LENGTH AS SPECIFIED IN THE "DECK REPAIR DETAILS" SHEET. THE CONTRACTOR AND/OR THE DEPARTMENT SHALL HAVE NO CLAIM WHATSOEVER AGAINST DESIGNER FIRM OR THE ENGINEER OF RECORD IF SUCH PRIOR DECK REPAIRS FAIL OR BECOME UNSOUND, OR IF NEW REPAIRS ARE NOT IN ACCORDANCE WITH THESE PLANS AND THE PROJECT SPECIAL PROVISIONS.

BRIDGE COORDINATES		
	LATITUDE	LONGITUDE
170171	35°42' 58.63"N	81°13' 23.66" W
170172	35°42' 59.33"N	81°13' 24.17" W
170177	35°43' 41.53"N	81°7' 22.73" W
170178	35°43' 42.08"N	81°7' 23.01" W
480006	35°44' 35.09"N	81°4' 28.94" W
480007	35°44' 35.49"N	81°4' 29.67" W
480051	35°45' 18.89"N	81°2' 43.06" W
480054	35°45' 19.51"N	81°2' 43.05" W
480065	35°45' 22.86"N	81°2' 34.02" W
480066	35°45' 23.54"N	81°2' 33.78" W
480072	35°46' 9.72"N	81°0' 23.56" W
480073	35°46' 10.10"N	81°0' 24.07" W
480096	35°47' 11.37"N	80°57' 29.77" W
480102	35°47' 11.85"N	80°57' 30.04" W
480104	35°47' 37.63"N	80°56' 9.35" W
480109	35°47' 38.07"N	80°56' 10.32" W
480123	35°48' 5.53"N	80°54' 18.79" W
480124	35°48' 5.99"N	80°54' 19.31" W

SAMPLE BAR REPLACEMENT	
SIZE	LENGTH
#3	6'-2"
#4	7'-4"
#5	8'-6"
#6	9'-8"
#7	10'-10"
#8	12'-0"
#9	13'-2"
#10	14'-6"
#11	15'-10"

BRIDGES: 170171, 170172, 170177, 170178  
480006, 480007, 480051, 480054  
480065, 480066, 480072, 480073  
480096, 480102, 480104, 480109  
480123, 480124

NOTE:  
SAMPLE BAR REPLACEMENT LENGTHS BASED ON 30" (SAMPLE LENGTH) PLUS TWO SPLICE LENGTHS AND f<sub>y</sub> = 60ksi.

PROJECT NO. I-5915B  
CATAWBA/IREDELL COUNTY  
BRIDGE NO. MULTIPLE

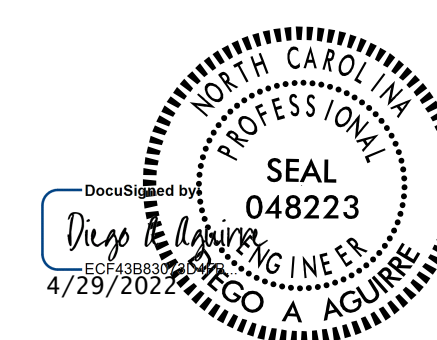

STATE OF NORTH CAROLINA DEPARTMENT OF TRANSPORTATION RALEIGH					
GENERAL NOTES					
REVISIONS					SHEET NO.
NO.	BY:	DATE:	NO.	BY:	DATE:
1			3		
2			4		
					S4
					TOTAL SHEETS 9

DRAWN BY : FIDEL L. FLORES	DATE : 01/2022
CHECKED BY : JACOB H. DUKE	DATE : 01/2022
DESIGN ENGINEER OF RECORD: DIEGO A. AGUIRRE	DATE : 01/2022

DOCUMENT NOT CONSIDERED  
FINAL UNLESS ALL  
SIGNATURES COMPLETED



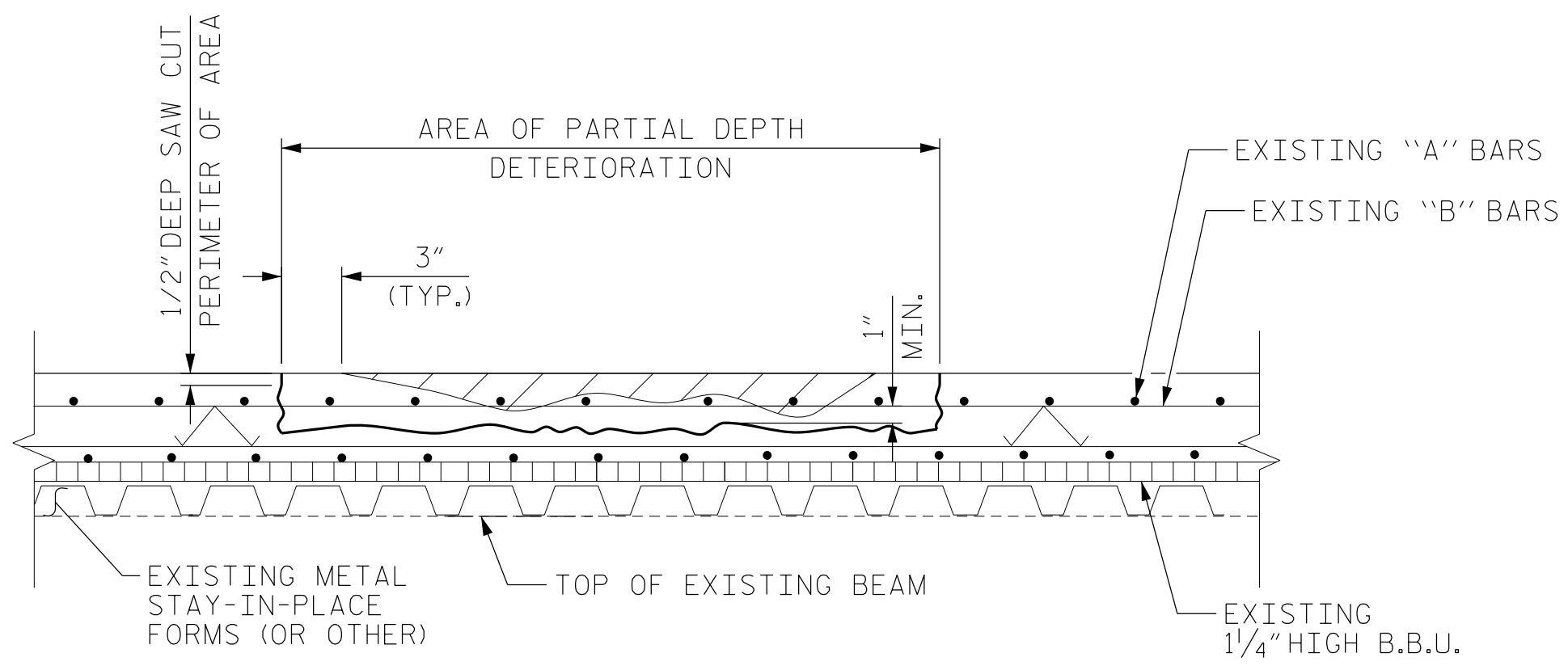

**CLASS II (PARTIAL DEPTH) REPAIR**

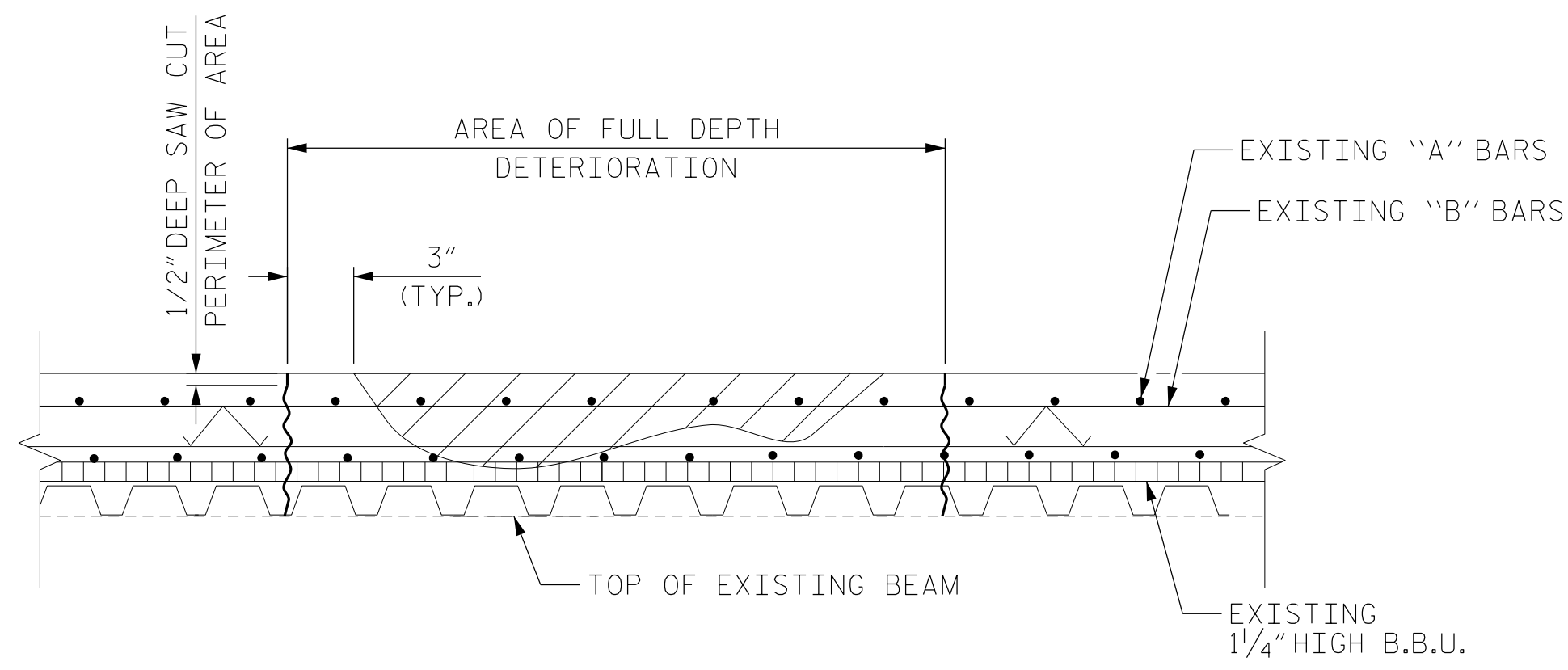

**CLASS III (FULL DEPTH) REPAIR**

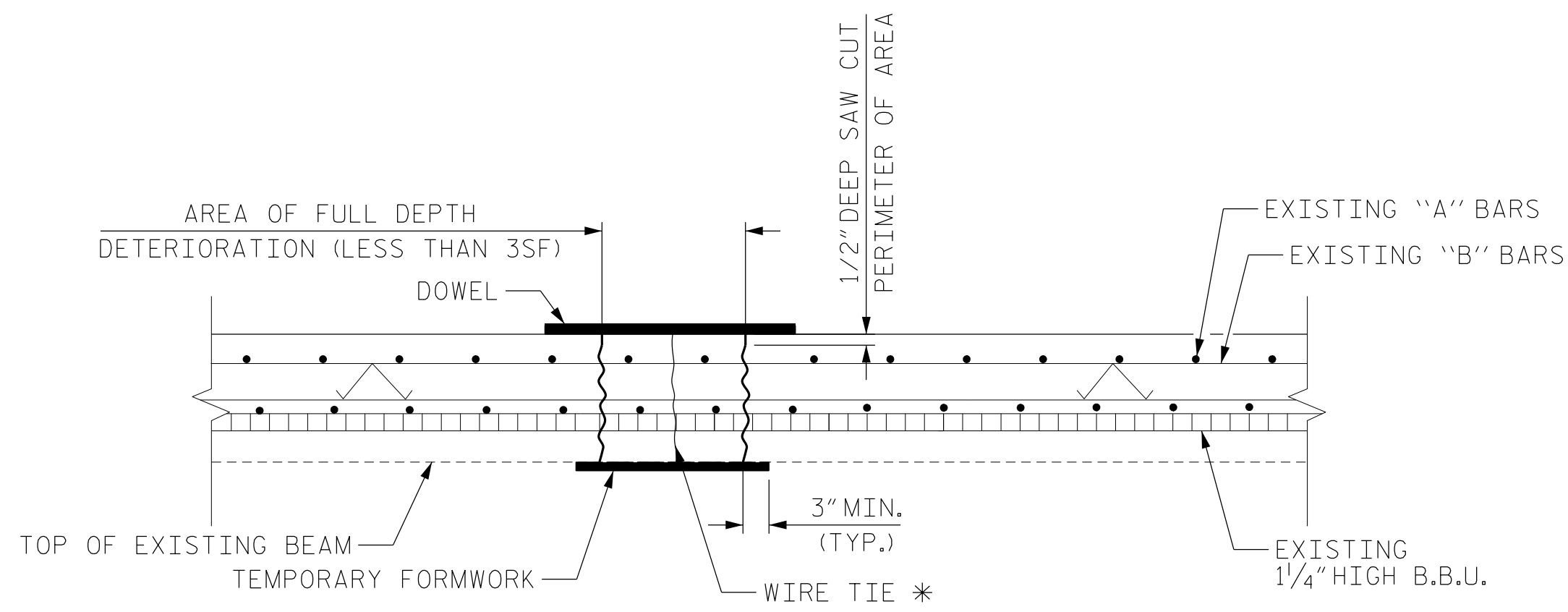

**FULL DEPTH REPAIR WITH TEMPORARY FORMWORK**

(FOR AREAS OF DETERIORATION EQUAL TO OR LESS THAN 3SF)

\* WIRE TIE TO BE KNOTTED BELOW TEMPORARY FORMWORK AND ATTACHED TO DOWEL THAT IS WIDER THAN FORMED FULL DEPTH HOLE. ROTATE DOWEL TO TIGHTEN FORMWORK AGAINST BOTTOM OF DECK.

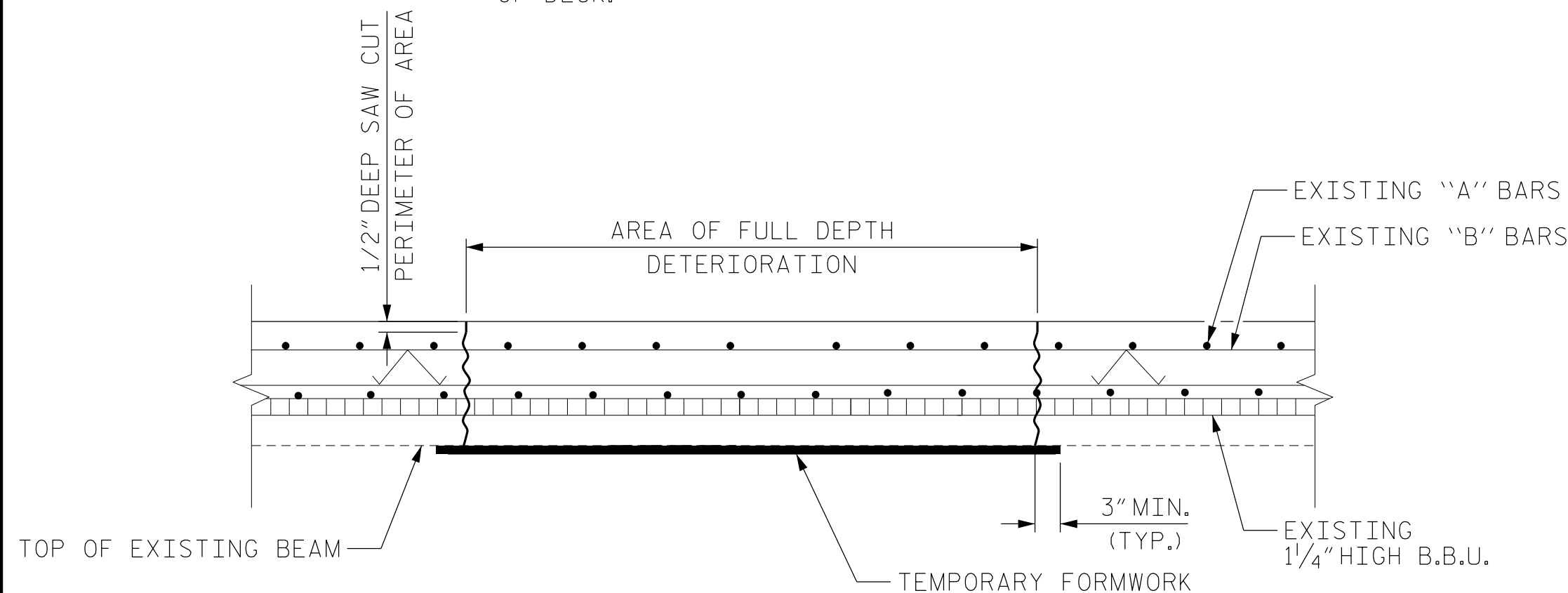

**FULL DEPTH REPAIR WITH TEMPORARY FORMWORK**

(FOR AREAS OF DETERIORATION GREATER THAN 3SF)

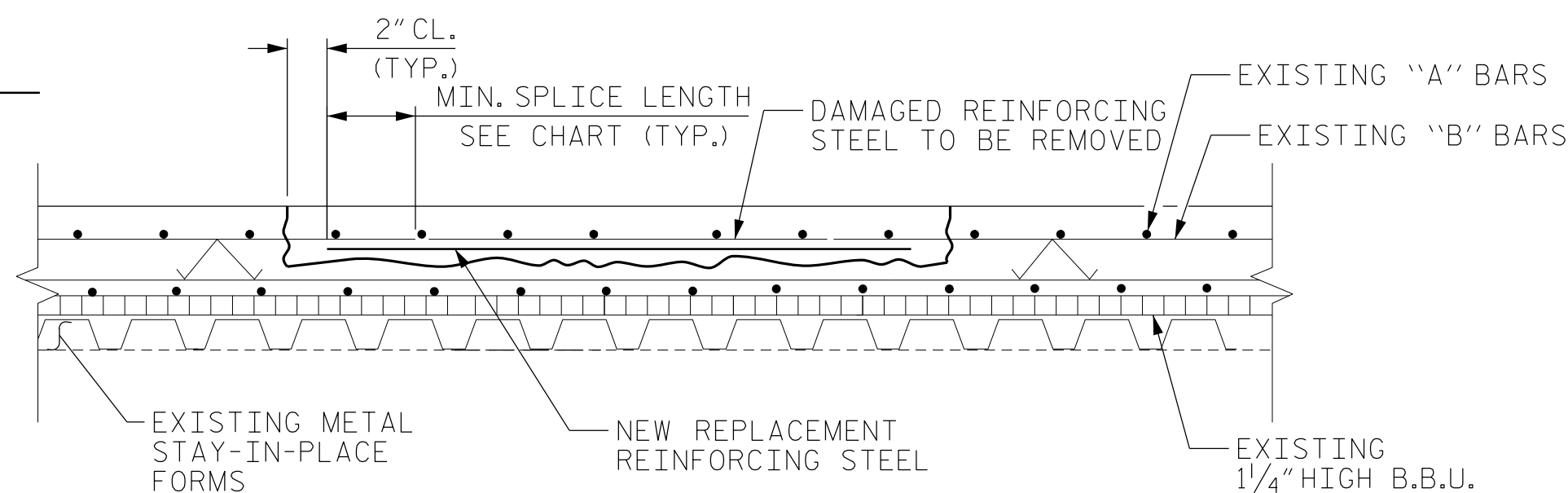

**REINFORCING STEEL REPAIR**

**NOTES**

- FOR AREAS TO BE REPAIRED, SEE "PLAN OF SPANS" SHEETS.
- ALL DECK REPAIRS SHALL BE COMPLETED PRIOR TO PLACEMENT OF OVERLAY.
- FOR CLASS II AND CLASS III SURFACE PREPARATION, SEE OVERLAY SURFACE PREPARATIONS SPECIAL PROVISION.
- FOR CONCRETE FOR DECK REPAIR, SEE SPECIAL PROVISIONS.
- FOR SHOTCRETE REPAIR, SEE SPECIAL PROVISIONS.
- THE CONTRACTOR SHALL SUBMIT WORKING DRAWINGS TO THE ENGINEER FOR APPROVAL PRIOR TO STARTING WORK FOR TEMPORARY FORMWORK. FOR SUBMITTALS OF WORKING DRAWINGS, SEE SPECIAL PROVISIONS.
- UPON REMOVAL OF TEMPORARY FORMWORK, ALL VOIDS AND HONEYCOMBS ON THE UNDERSIDE OF DECK SURFACE SHALL BE FILLED WITH THE SAME MATERIAL AS USED FOR THE PATCH, AND FINISHED TO CONFORM TO THE SURROUNDING CONCRETE SURFACE.
- NO FORMWORK SHALL BE LEFT IN PLACE.
- FOR ADDITIONAL "CONCRETE REPAIR NOTES", SEE "CONCRETE RESTORATION DETAILS" SHEET.

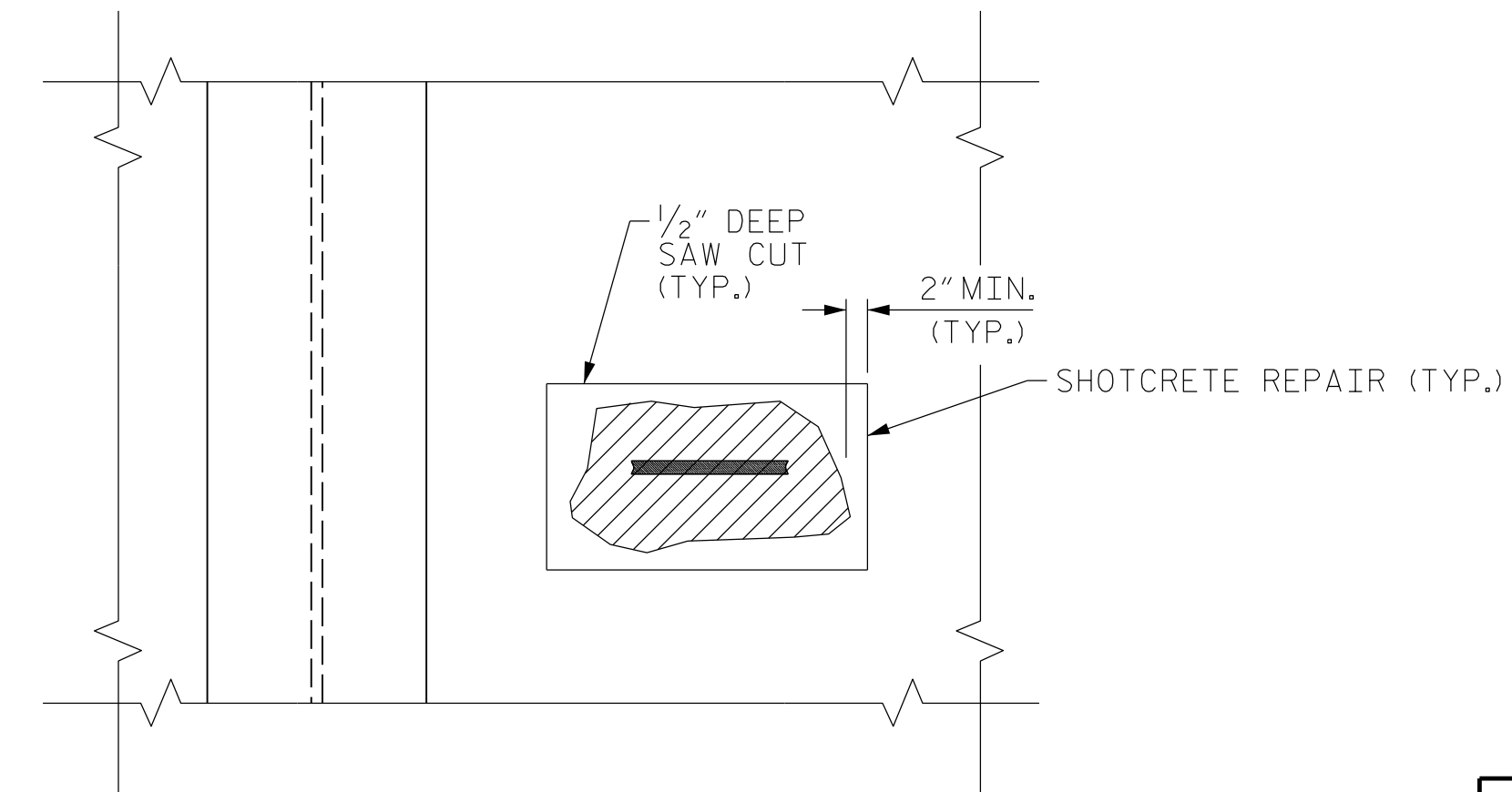

**SECTION D-D**

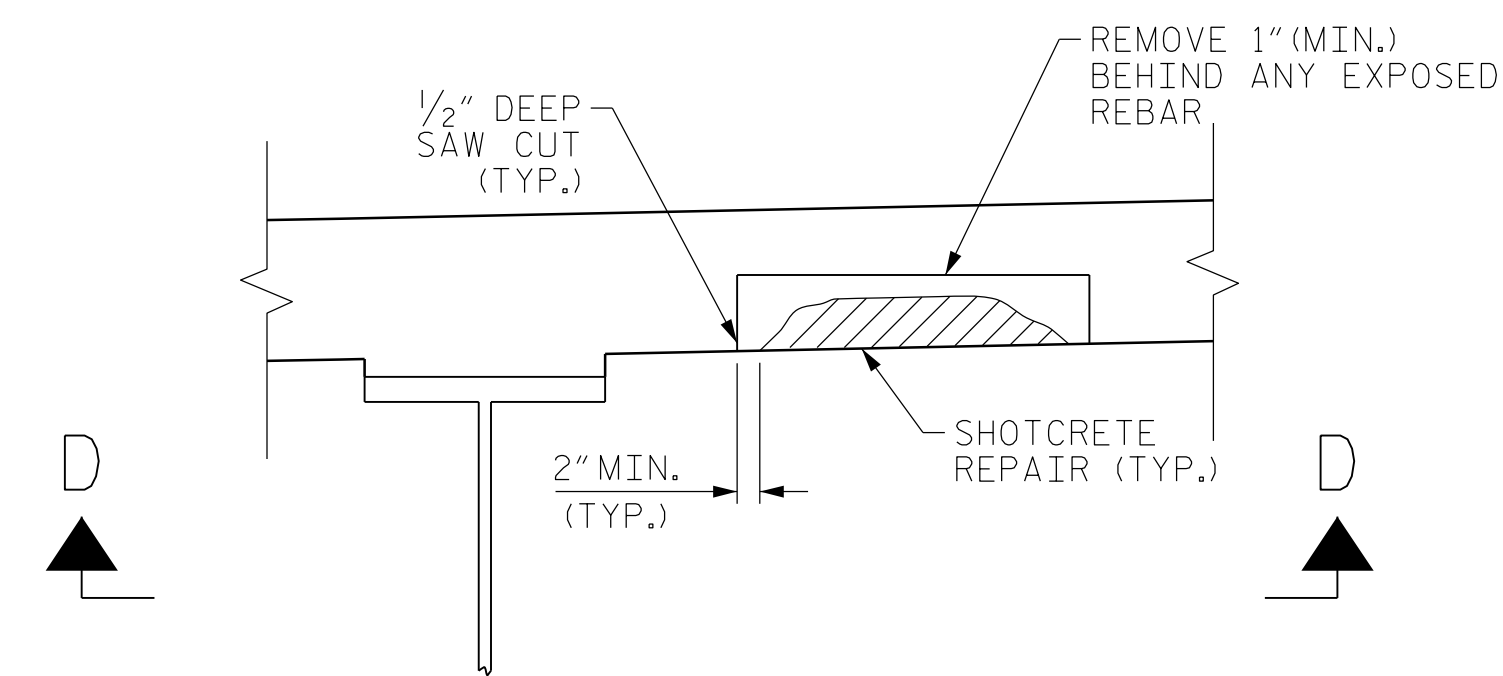

**TYPICAL SECTION**

**UNDERSIDE OF DECK REPAIR**

BAR SIZE	SUPERSTRUCTURE REINFORCING STEEL LENGTHS ARE BASED ON THE FOLLOWING MINIMUM SPLICE LENGTHS				
	SUPERSTRUCTURE EXCEPT APPROACH SLABS, PARAPET, AND BARRIER RAIL		APPROACH SLABS		PARAPET AND BARRIER RAIL
	EPOXY COATED	UNCOATED	EPOXY COATED	UNCOATED	
#4	2'-0"	1'-9"	2'-0"	1'-9"	2'-9"
#5	2'-6"	2'-2"	2'-6"	2'-2"	3'-5"
#6	3'-0"	2'-7"	3'-10"	2'-7"	4'-4"
#7	5'-3"	3'-6"			
#8	6'-10"	4'-7"			

BRIDGES: 170171, 170172, 170177, 170178  
 480006, 480007, 480051, 480054  
 480065, 480066, 480072, 480073  
 480096, 480102, 480104, 480109  
 480123, 480124

PROJECT NO. I-5915B  
 COUNTY \_\_\_\_\_  
 BRIDGE NO. MULTIPLE

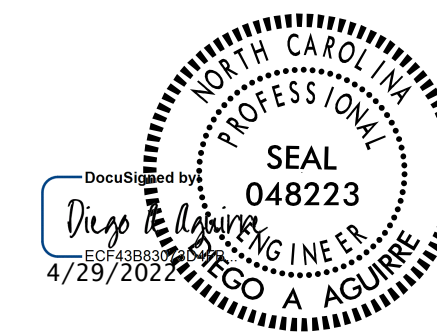

301 FAYETTEVILLE ST., SUITE 1500  
 RALEIGH, NC 27601 (919) 882-7839  
 NC FIRM LICENSE: C-1506

STATE OF NORTH CAROLINA DEPARTMENT OF TRANSPORTATION RALEIGH STANDARD					
DECK REPAIR DETAILS					
REVISIONS					SHEET NO.
NO.	BY:	DATE:	NO.	BY:	DATE:
1			3		
2			4		
					S5
					TOTAL SHEETS 9

DRAWN BY : DIEGO A. AGUIRRE DATE : 01/2022  
 CHECKED BY : FIDEL L. FLORES DATE : 01/2022  
 DESIGN ENGINEER OF RECORD: DIEGO A. AGUIRRE DATE : 01/2022

DOCUMENT NOT CONSIDERED  
 FINAL UNLESS ALL  
 SIGNATURES COMPLETED



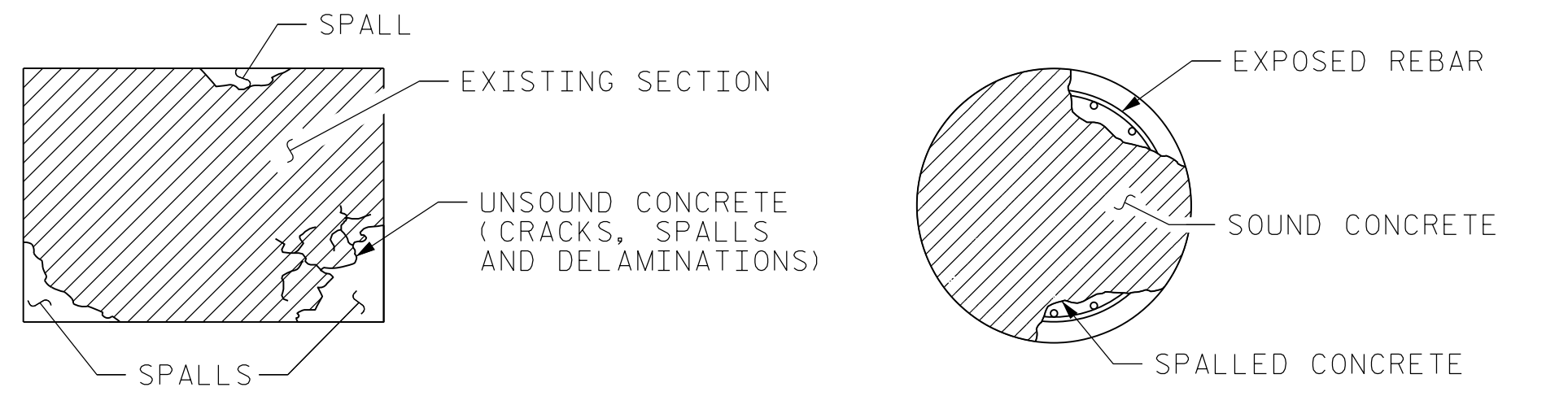

TYPICAL DELAMINATIONS AND SPALLS

TYPICAL SPALL WITH EXPOSED REBAR

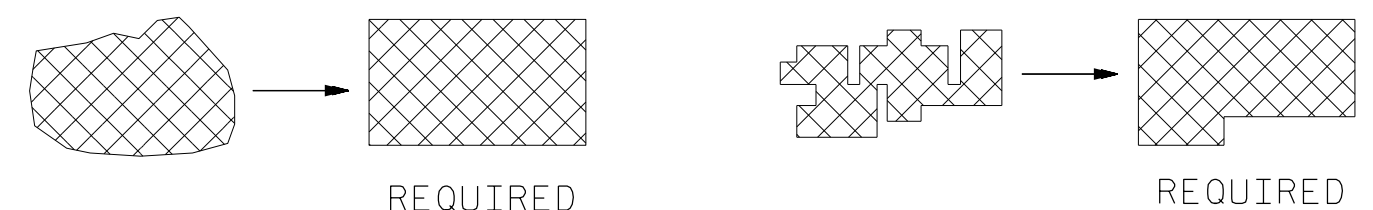

SIMPLE PATCH CONFIGURATION

AT CORNER LOCATIONS PROVIDE RIGHT ANGLE CUTS. PATCH CONFIGURATION SHALL BE KEPT AS SIMPLE AS POSSIBLE. INDIVIDUAL REPAIR AREAS WITHIN 2 FEET SHALL BE JOINED AT THE DIRECTION OF THE ENGINEER.

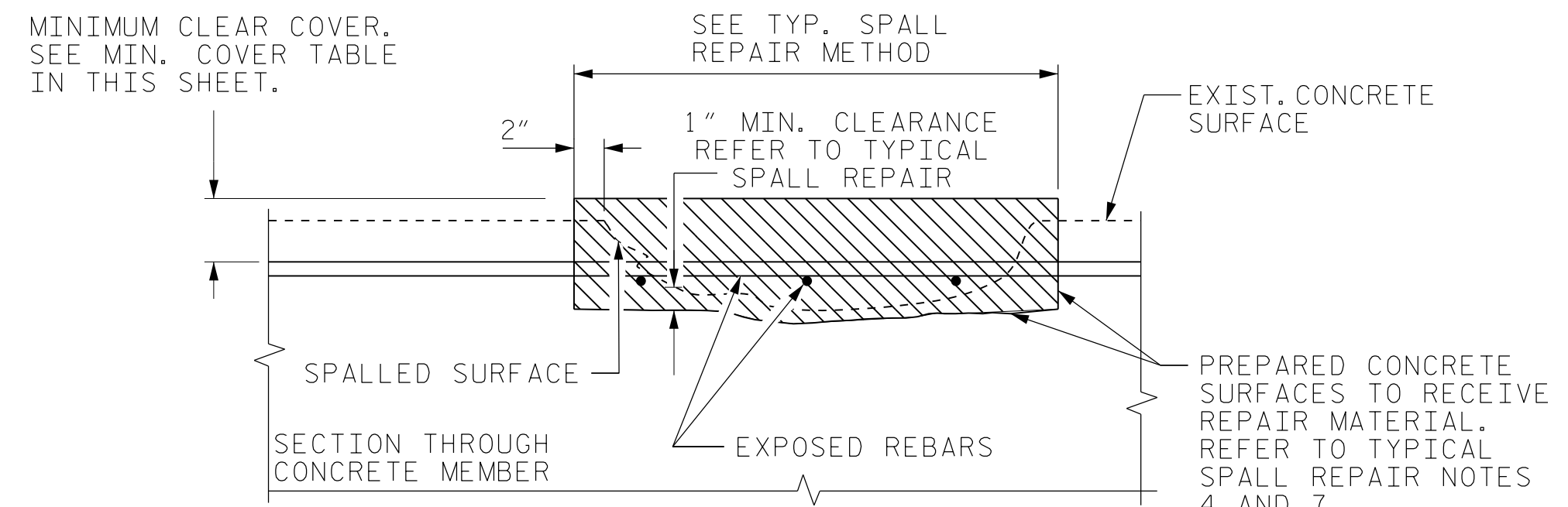

EXPOSING AND UNDERCUTTING REINFORCING STEEL

APPLICABLE TO HORIZONTAL, VERTICAL, AND OVERHEAD LOCATIONS

MIN. CONCRETE COVER TABLE		
STRUCTURE ELEMENT	COVER	
	ALL OTHER SITES	CORROSIVE SITES
Bridge Deck to top of slab to bottom of slab	2 1/2" (65mm)	2 1/2" (65mm)
	1 1/4" (32mm)	1 1/4" (32mm)*
Footings and Pile Caps to top face to all other faces	2" (50mm)	4" (100mm)
	3" (75mm)	4" (100mm)
Bent Caps to bottom of cap to ends of cap to top of cap to sides of cap	3" (75mm)	4" (100mm)
	2" (50mm)	3" (75mm)
	2" (50mm)	3" (75mm)
	2" (50mm)	3" (75mm)
Columns (spiral)	2" (50mm)	3" (75mm)
Drilled Piers (spiral)	5" (125mm)**	6" (150mm)**
Culverts to bottom of bottom slabs and footings to all other faces	3" (75mm)	3" (75mm)
	2" (50mm)	2" (50mm)
Approach Slabs	2" (50mm)	2" (50mm)

\* WHEN USING REMOVEABLE FORMS, COVER SHALL BE INCREASED TO 2 1/2"  
 \*\* IN THE EVENT THE DRILLED PIER EXTENDS INTO A BENT CAP OR PILE CAP, THE COVER MAY BE REDUCED TO 4"

### TYPICAL SPALL REPAIR

- FOR CONCRETE RESTORATION, REMOVE AND REPAIR UNSOUND CONCRETE FROM AREAS TO BE REPAIRED IN ACCORDANCE WITH THIS SHEET AND THE PROJECT SPECIAL PROVISIONS. AREAS WELL ADHERED TO EXISTING STRAND OR REINFORCEMENT SHALL REMAIN.
- ALL UNSOUND CONCRETE MUST BE REMOVED, HOWEVER, PRESTRESSED STRANDS SHOULD NOT BE DISTURBED UNLESS ABSOLUTELY NECESSARY. USE EXTREME CARE TO NOT DAMAGE STRANDS.
- ALL REPAIRS SHALL BE MARKED FOR APPROVAL OF APPROXIMATE PERIMETER PRIOR TO INITIATION OF WORK.
- THE CONTRACTOR SHALL SUBMIT A PLAN FOR CONTROL AND DISPOSAL OF DEBRIS TO THE ENGINEER FOR APPROVAL.
- ANY REINFORCEMENT WHICH IS LOOSE SHALL BE SECURED IN PLACE BY TYING TO OTHER SECURED BARS OR BY OTHER APPROVED METHODS. LAP SPLICES SHALL BE INSTALLED IN ACCORDANCE WITH THE TABLE BELOW. REFER TO GENERAL NOTES FOR DOWEL DETAIL (IF NECESSARY).
- CLEAN EXPOSED REBARS AND ANY LOOSE CONCRETE OR ABRASIVES BY SANDBLASTING OR APPROVED ALTERNATE. CLEANED STEEL SHALL NOT BE LEFT EXPOSED FOR MORE THAN 72 HOURS PRIOR TO ENCAPSULATION OF CONCRETE.
- AN APPROVED CEMENTITIOUS BASED BONDING AGENT SHALL BE USED ON ALL EXPOSED CONCRETE SURFACES IN ACCORDANCE WITH MANUFACTURER'S RECOMMENDATIONS BEFORE THE REPAIR MATERIAL IS APPLIED.
- FILL VOIDS WITH REPAIR MATERIAL IN ACCORDANCE WITH THE PROJECT SPECIAL PROVISIONS AND NCDOT SPECIFICATIONS. NOTE THAT ANY REPAIR MATERIAL APPLIED TO OVERHEAD LOCATIONS SHALL BE SPECIFICALLY DESIGNATED FOR OVERHEAD USE BY THE MANUFACTURER'S SPECIFICATIONS.

### TYPICAL CRACK REPAIR

- OBTAIN ENGINEER'S APPROVAL TO CARRY OUT CRACK REPAIR (IN LIEU OF SPALL REPAIR) FOR CASES WHERE ADJACENT CONCRETE IS OTHERWISE SOUND AND CRACKING IS NOT A RESULT OF CORRODING REINFORCEMENT.
- ADDRESS CRACKS IN NEW CONSTRUCTION IN ACCORDANCE WITH PROJECT SPECIAL PROVISIONS. ADDRESS EXISTING CRACKS IN ACCORDANCE WITH THIS SHEET AND PROJECT SPECIAL PROVISIONS.
- REMOVE UNSOUND CONCRETE FROM CRACK AREA.
- THE CONTRACTOR SHALL SUBMIT A PLAN FOR CONTROL AND DISPOSAL OF DEBRIS TO THE ENGINEER FOR APPROVAL.
- FOR CRACKS UP TO 1/8" USE AN EPOXY RESIN WITH MINIMUMS OF VISCOSITY OF 325 CPS, 28 DAY COMPRESSIVE STRENGTH OF 13000 PSI. FOR CRACKS 1/8" TO 1/4", USE AN INJECTION GEL OR EQUAL NON-SAG PASTE WITH 28 DAY COMPRESSIVE STRENGTH OF 10000 PSI.
- TO SEAL CRACK SURFACES PRIOR TO CRACK INJECTION, USE INJECTION GEL WITH MINIMUM 28 DAY COMPRESSIVE STRENGTH OF 12000 PSI.
- ENGINEER TO APPROVE CRACK AND CAP SEAL MATERIAL PRIOR TO BEGINNING OF CONSTRUCTION.
- APPLY CLASS II FINISH AT COMPLETION OF CRACK REPAIR TO REMOVE FINS OR KNOBS.

### DOWEL DETAILS & NOTES

DOWEL DIMENSIONS (UNLESS OTHERWISE NOTED)			
DOWEL SIZE	HOLE DIAMETER	EMBEDMENT LENGTH	MIN LAP LENGTH
4	5/8"	8"	1'-9"
5	3/4"	9"	2'-2"
6	7/8"	11"	2'-7"
8	1 1/8"	1'-4"	4'-6"

NOTES: ANY REQUIRED DOWEL HOLES SHALL BE DRILLED INTO EXISTING CONCRETE ACCORDING TO THE DETAIL AND NCDOT SPECIFICATIONS.

NOTIFY THE ENGINEER OF ANY BROKEN BARS OR BARS WHICH ARE DETERMINED TO HAVE A SECTION LOSS OF 25% OR GREATER.

INSTALL DOWELS IN ACCORDANCE WITH NCDOT SPECIFICATIONS.

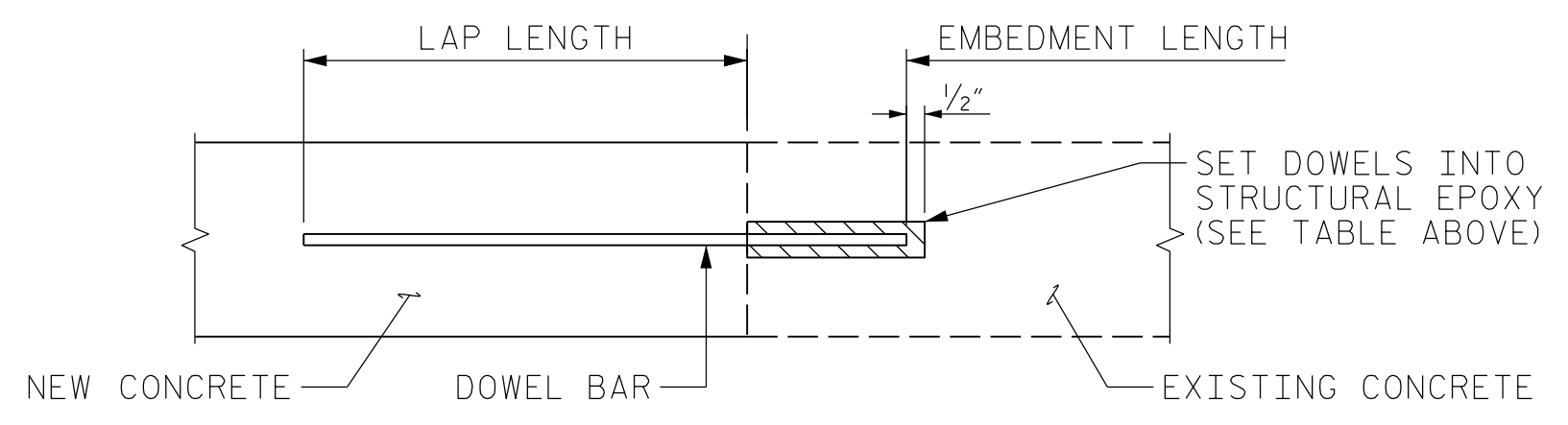

### CONCRETE REPAIR NOTES

- PERFORM A SOUNDING SURVEY IN THE PRESENCE OF THE ENGINEER TO IDENTIFY ALL LOCATIONS IN NEED OF CONCRETE REPAIR.
- GAIN CONCURRENCE ON ALL REPAIR AREAS AT EACH LOCATION PRIOR TO COMMENCING WORK AT THE BENT.
- THE DETERIORATED AREAS SHOWN ON OTHER SHEETS ARE BASED ON THE BRIDGE INSPECTION REPORT, AND PARTIAL FIELD REVIEWS OF THE STRUCTURE. AS SUCH, THEY ARE FOR INFORMATIONAL PURPOSES, SUBJECT TO CHANGE BASED ON CONTINUING DETERIORATION.
- GENERALLY EXTEND REPAIR AREAS 2"-3" INTO SOUND CONCRETE BEYOND EDGE OF SPALLS AND SQUARE OFF AREAS IN ACCORDANCE WITH DETAILS ON THIS SHEET.
- THE METHOD USED TO DELINEATE THE AREAS OF UNSOUND CONCRETE TO BE REPAIRED SHALL NOT PERMANENTLY MARK THE CONCRETE, LEAVE ANY RESIDUE AFTER REMOVAL, OR REQUIRE HARSH CHEMICALS TO REMOVE.
- THE CONTRACTOR SHALL REMOVE THE DETERIORATED CONCRETE IN ACCORDANCE WITH THE GUIDELINES SET IN THESE NOTES, IN THE PROJECT SPECIAL PROVISIONS, AND THE STANDARD SPECIFICATIONS.
- REMOVE UNSOUND CONCRETE TO THE EXTENT NECESSARY. MINIMUM OF 1" BEHIND REBAR AND MINIMUM OF 2" CLEARANCE TO SAWCUT.
- REINFORCING STEEL, WHICH IS DETERMINED BY THE ENGINEER TO BE REPLACED, SHALL BE REMOVED TO A POINT WHERE IT IS SOUND. THE PATCH SHALL EXTEND A SUFFICIENT DISTANCE BEYOND THIS POINT TO DEVELOP A SPLICE LENGTH SPECIFIED IN THE TABLE ON THIS SHEET.
- FOR REPAIRS OVER TRAFFIC AND SHALLOW REPAIRS THAT DO NOT ENGAGE REINFORCEMENT, ANCHOR PATCH MATERIAL USING 1/4" GALVANIZED BOLTS, EPOXY ANCHORED WITH 2" EMBEDMENT. PLACE BOLTS IN A 6" GRID. USE A LATEX OR EPOXY PATCH MATERIAL FOR IMPROVED BOND.
- CONCRETE COVER SHOWN IN THE PLANS DOES NOT INCLUDE PLACEMENT OR FABRICATION TOLERANCES UNLESS SHOWN AS "MINIMUM COVER". SEE NCDOT SPECIFICATIONS FOR ALLOWABLE REINFORCEMENT PLACEMENT TOLERANCES.
- WHEN PROPOSED CONCRETE REPAIRS (OR DETERMINED LOCATIONS) ARE ADJACENT TO A CORNER, REPAIR ON THE ADJACENT EDGE SHOULD BE ANTICIPATED IN ADDITION TO THE AREA SHOWN ON SUBSTRUCTURE CONCRETE REPAIR SHEETS. THE CONTRACTOR IS RESPONSIBLE FOR THIS REPAIR AT ALL LOCATIONS REGARDLESS OF CALL-OUT(S) ON RESPECTIVE SHEET(S).
- FINISH CONCRETE SURFACES IN ACCORDANCE WITH THE LATEST NCDOT SPECIFICATIONS. MATCH EXISTING FINISH ON ALL EXPOSED EDGES UNLESS OTHERWISE NOTED. A CLASS 5 FINISH COATING SHALL BE APPLIED TO THE BEAM ENDS WHERE CONCRETE REPAIRS HAVE BEEN PERFORMED, MATCHING THE COLOR OF SURROUNDING CONCRETE.
- ALL REINFORCING STEEL SHALL BE ASTM A615-96, GRADE 60. REINFORCEMENT DETAIL DIMENSIONS ARE OUT-TO-OUT OF BARS. ALL DIMENSIONS PERTAINING TO LOCATION OF REINFORCEMENT ARE TO CENTERLINE OF BARS EXCEPT WHERE THE CLEAR DIMENSION IS SHOWN TO FACE OF CONCRETE. ANY DAMAGE TO EXISTING REINFORCING STEEL, DURING CONTRACTOR'S OPERATIONS, SHALL BE REPAIRED AS DIRECTED BY THE ENGINEER AND PERFORMED AT NO ADDITIONAL COST TO THE DEPARTMENT.
- FOR ADHESIVELY ANCHORED DOWELS OR ANCHOR BOLTS, SEE STANDARD SPECIFICATIONS.
- FOR SHOTCRETE REPAIRS, SEE SPECIAL PROVISIONS.
- FOR CONCRETE REPAIRS, SEE SPECIAL PROVISIONS.
- FOR EPOXY RESIN INJECTION (ERT), SEE SPECIAL PROVISIONS.

LAP SPLICE TABLE	
BAR SIZE	LAP SPLICE LENGTH
4	1'-9"
5	2'-2"
6	2'-7"
7	3'-6"
8	4'-6"
9	5'-10"
10	7'-4"

BRIDGES: 170171, 170172, 170177, 170178  
 480006, 480007, 480051, 480054  
 480065, 480066, 480072, 480073  
 480096, 480102, 480104, 480109  
 480123, 480124

PROJECT NO. I-5915B  
 COUNTY \_\_\_\_\_  
 BRIDGE NO. MULTIPLE

SHEET 1 OF 2



STATE OF NORTH CAROLINA  
 DEPARTMENT OF TRANSPORTATION  
 RALEIGH  
**CONCRETE RESTORATION DETAILS**

DRAWN BY : DIEGO A. AGUIRRE DATE : 01/2022  
 CHECKED BY : JACOB H. DUKE DATE : 01/2022  
 DESIGN ENGINEER OF RECORD: DIEGO A. AGUIRRE DATE : 01/2022

DOCUMENT NOT CONSIDERED FINAL UNLESS ALL SIGNATURES COMPLETED

REVISIONS						SHEET NO.
NO.	BY:	DATE:	NO.	BY:	DATE:	
1			3			S6
2			4			TOTAL SHEETS 9



SPALLED, DELAMINATED OR CRACKED CONCRETE (REMOVE UNTIL SOUND CONCRETE IS FOUND AND 1" MIN. BEHIND ANY EXPOSED REBAR (TYP.))

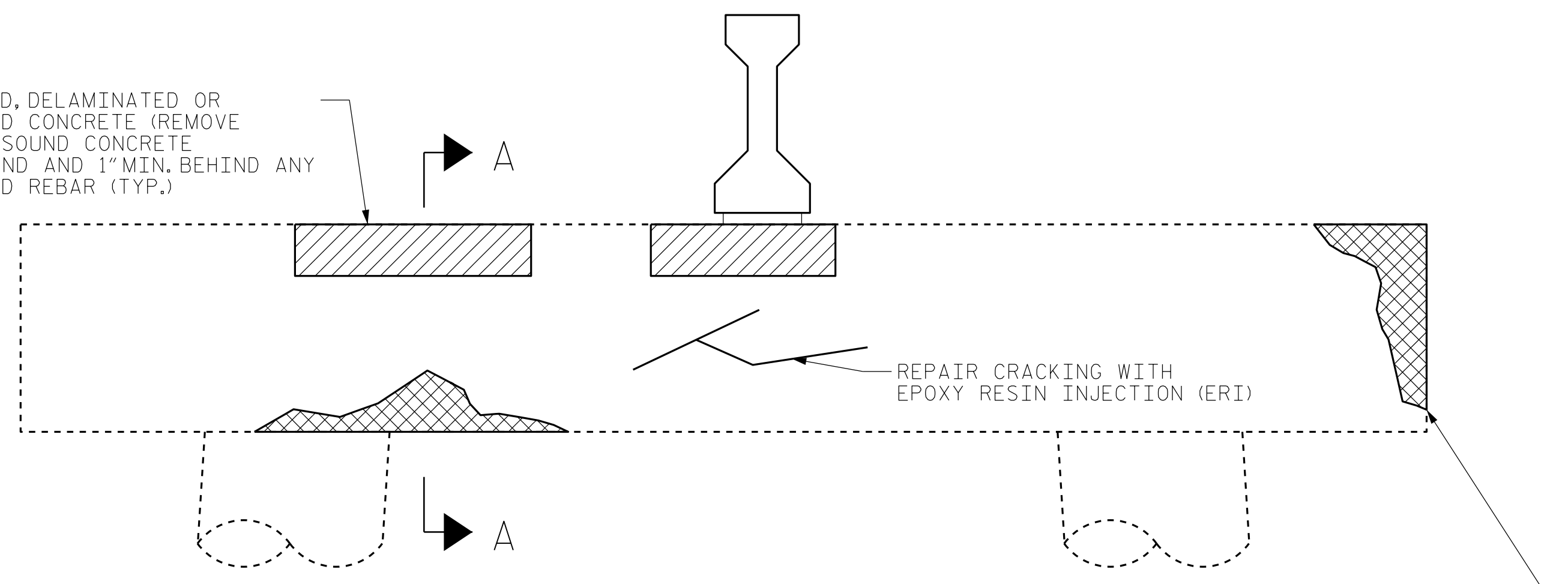

**CAP REPAIRS**

(COLUMN BENT SHOWN PILE BENTS SIMILAR)

REPAIR ALL SPALLED, DELAMINATED OR CRACKED CONCRETE AREAS NOT OCCURRING AT BEAM BEARING AREAS PER PLANS AND PER THE ENGINEER USING SHOTCRETE OR "FORM AND POUR" AT THE CONTRACTOR'S OPTION (SEE NOTES)

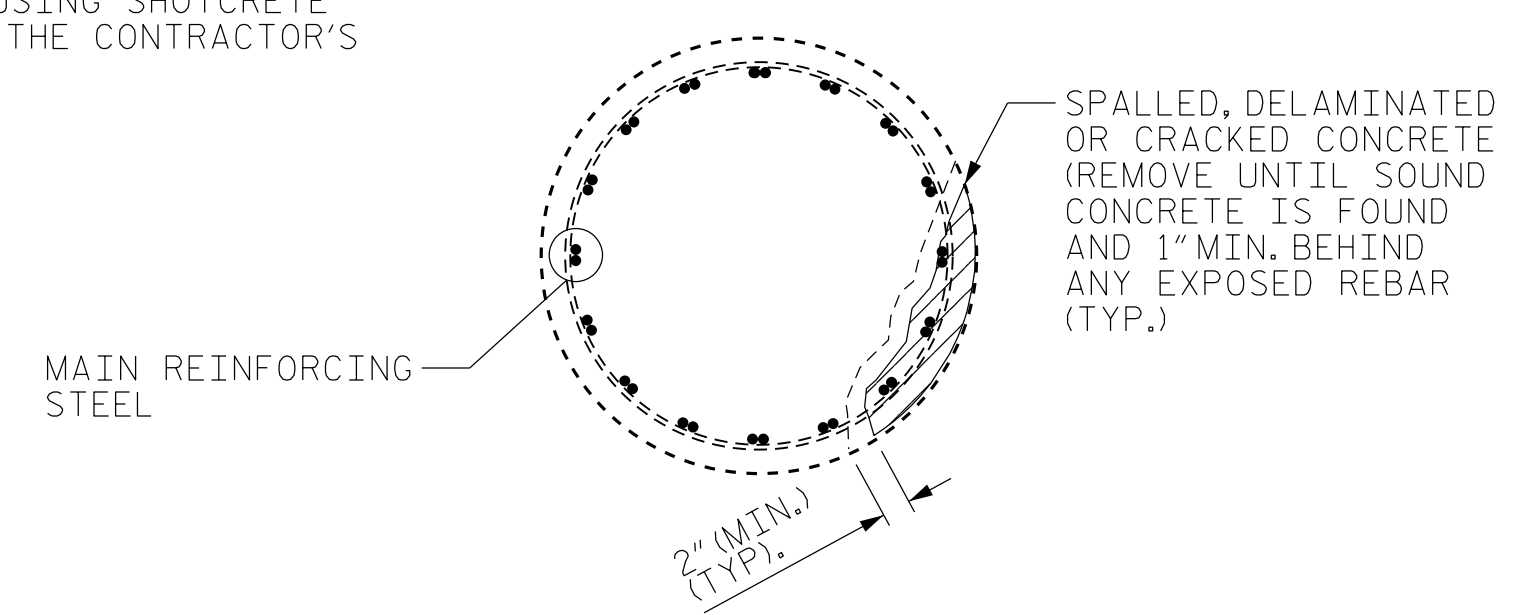

**PLAN OF CIRCULAR COLUMN**

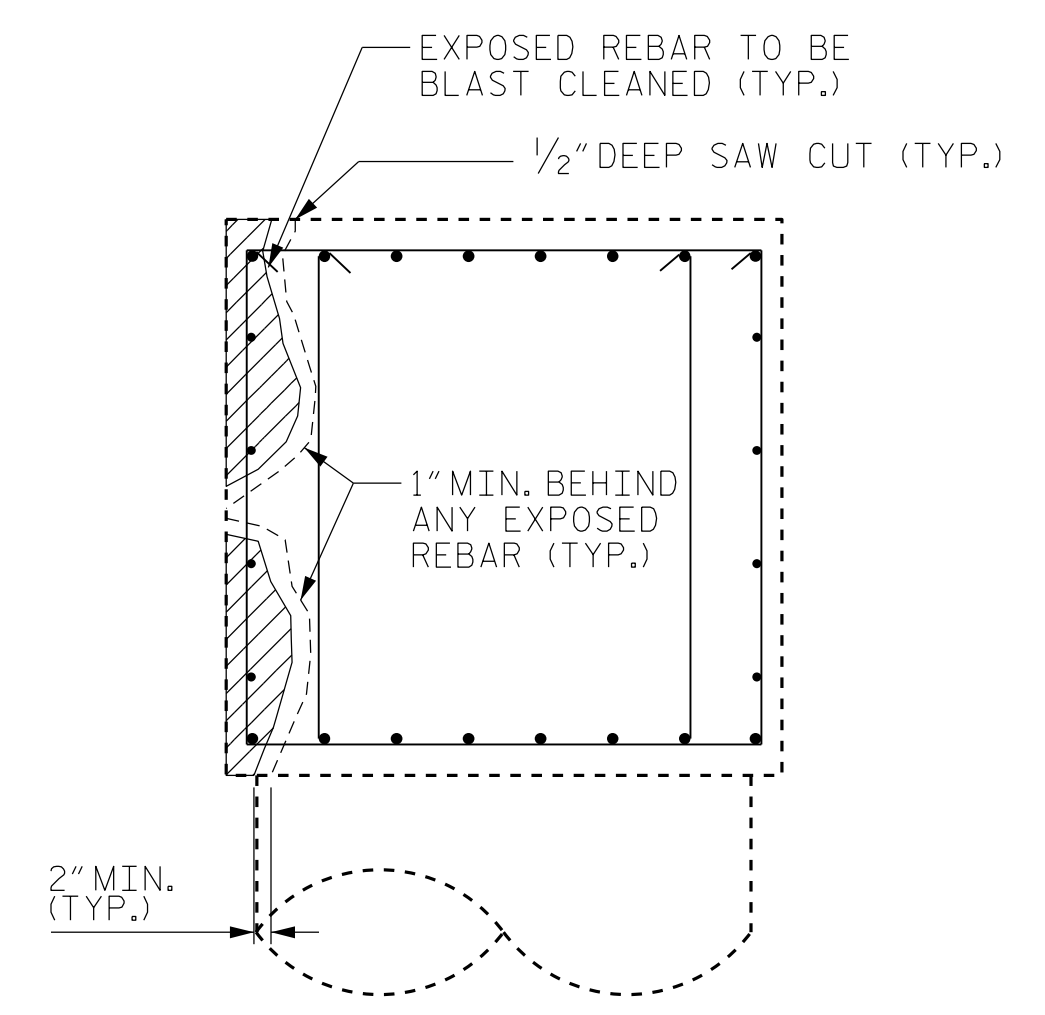

**SECTION A-A**

**BENT CAP REPAIRS**

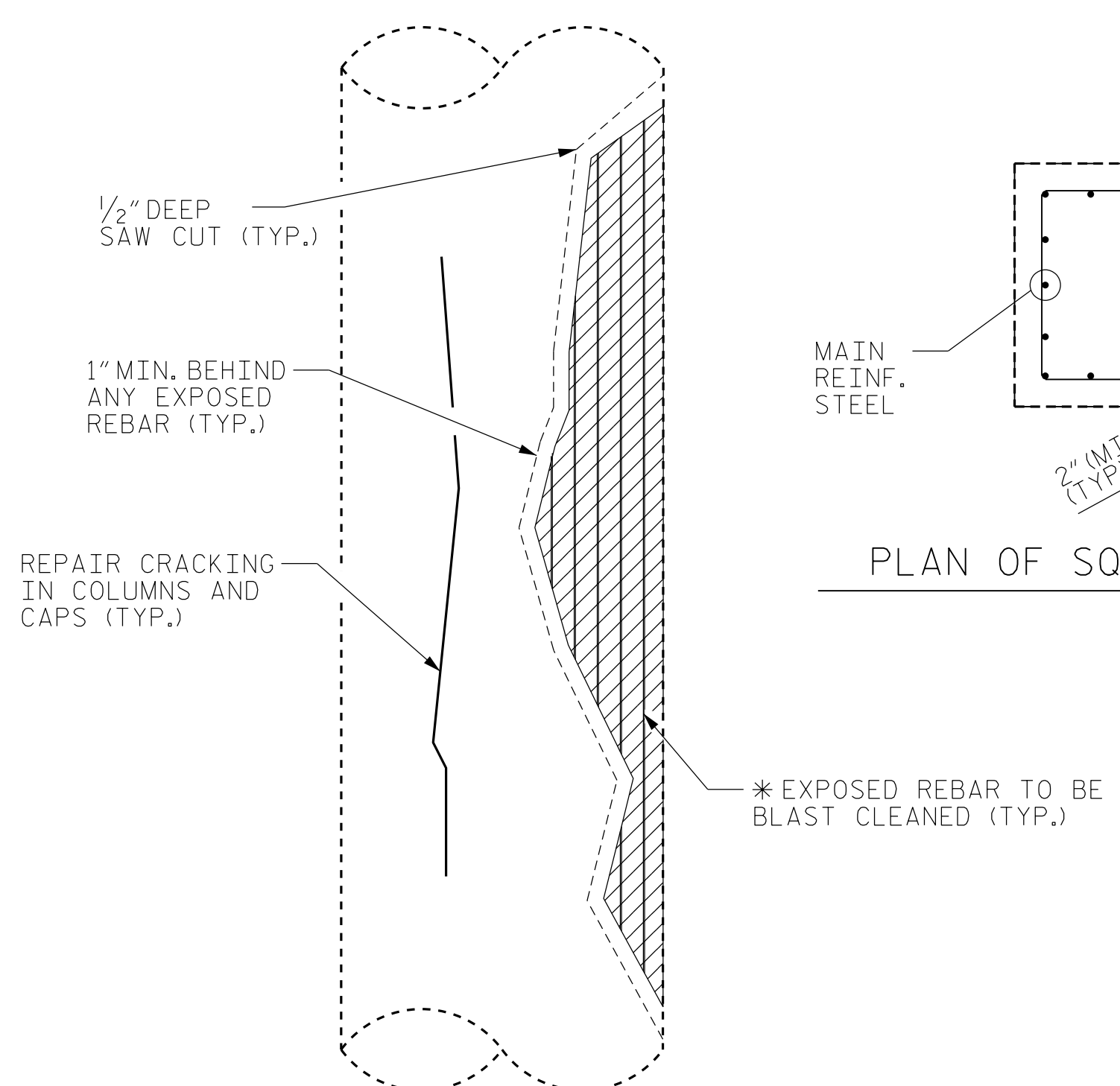

**ELEVATION OF COLUMN (SQUARE COLUMNS SIMILAR)**

\* REPAIR LENGTH SHALL NOT EXCEED 10 VERTICAL FEET AT ONCE OR 1/2 COLUMN DIAMETER.

**COLUMN REPAIRS**

**SUBSTRUCTURE REPAIR NOTES:**

1. WORK THIS SHEET WITH REPAIR METHODS AND CONCRETE REPAIR NOTES IN "CONCRETE RESTORATION DETAILS" SHEET 1.
2. TYPICAL BENT CAP REPAIRS ARE SHOWN IN THIS SHEET. REPAIR DETAILS SIMILAR FOR END BENT CAPS.
3. THE METHOD USED TO DELINEATE THE AREAS OF UNSOUND CONCRETE TO BE REPAIRED SHALL NOT PERMANENTLY MARK THE CONCRETE, LEAVE ANY RESIDUE AFTER REMOVAL, OR REQUIRE HARSH CHEMICALS TO REMOVE.
4. THE CONTRACTOR SHALL REMOVE THE DETERIORATED CONCRETE IN ACCORDANCE WITH THE GUIDELINES SET IN THESE NOTES, IN THE SPECIAL PROVISIONS, AND THE STANDARD SPECIFICATIONS.
5. REMOVE UNSOUND CONCRETE TO THE EXTENT NECESSARY, A MINIMUM OF 1" BEHIND REBAR AND MINIMUM CLEARANCE OF 2" TO SAWCUT.
6. REINFORCING STEEL WHICH IS DETERMINED BY THE ENGINEER TO BE REPLACED, SHALL BE REMOVED TO A POINT WHERE IT IS SOUND. THE PATCH SHALL EXTEND A SUFFICIENT DISTANCE BEYOND THIS POINT TO DEVELOP A SPLICE LENGTH SPECIFIED IN THE TABLE ON THIS SHEET.
7. IF ANY AREA IS DETERMINED TO BE UNSTABLE DURING THE REPAIR PROCESS AS DETERMINED BY THE ENGINEER, STOP THE CURRENT REPAIR PROCEDURE, SHORE THE AREA AND PERFORM A "FORM AND POUR" CONCRETE REPAIR.
8. NO MORE THAN 1/3 OF THE CAP OR PILE CROSS SECTIONAL AREA SHALL BE REMOVED AT ONE TIME. SHOULD IT BECOME NECESSARY TO REMOVE MORE THAN 30% OF THE CROSS SECTIONAL AREA, NOTIFY THE ENGINEER PRIOR TO PROCEEDING.
9. SIMULTANEOUS REMOVAL OF UNSOUND CONCRETE MAY BE PERMITTED ON MORE THAN ONE FACE OF A CAP AND/OR PILE, BUT NO MORE THAN 1/3 OF THE CIRCUMFERENCE SHALL BE REMOVED AT A TIME. IF REMOVAL EXTENDS MORE THAN 1-1/2" BEHIND THE MAIN REINFORCING BARS, NOTIFY THE ENGINEER PRIOR TO PROCEEDING.
10. REPAIRS TO THE BENT CAPS MAY REQUIRE BRIDGE JACKING. FOR BRIDGE JACKING, SEE SPECIAL PROVISIONS.
11. FOR SUBSTRUCTURE REPAIRS, SEE "SUBSTRUCTURE REPAIRS" SHEETS.

LEGEND	
	CONCRETE REPAIR AREA
	SHOTCRETE REPAIR AREA
	EPOXY RESIN INJECTION (ERI)

BRIDGES: 170171, 170172, 170177, 170178  
 480006, 480007, 480051, 480054  
 480065, 480066, 480072, 480073  
 480096, 480102, 480104, 480109  
 480123, 480124

PROJECT NO. I-5915B  
 COUNTY \_\_\_\_\_  
 BRIDGE NO. MULTIPLE

SHEET 2 OF 2



STATE OF NORTH CAROLINA  
 DEPARTMENT OF TRANSPORTATION  
 RALEIGH  
**CONCRETE RESTORATION  
 DETAILS**  
 SUBSTRUCTURE

DRAWN BY : JACOB H. DUKE DATE : 01/2022  
 CHECKED BY : DIEGO A. AGUIRRE DATE : 01/2022  
 DESIGN ENGINEER OF RECORD: DIEGO A. AGUIRRE DATE : 01/2022

DOCUMENT NOT CONSIDERED  
 FINAL UNLESS ALL  
 SIGNATURES COMPLETED

REVISIONS						SHEET NO.
NO.	BY:	DATE:	NO.	BY:	DATE:	TOTAL SHEETS
1			3			9
2			4			

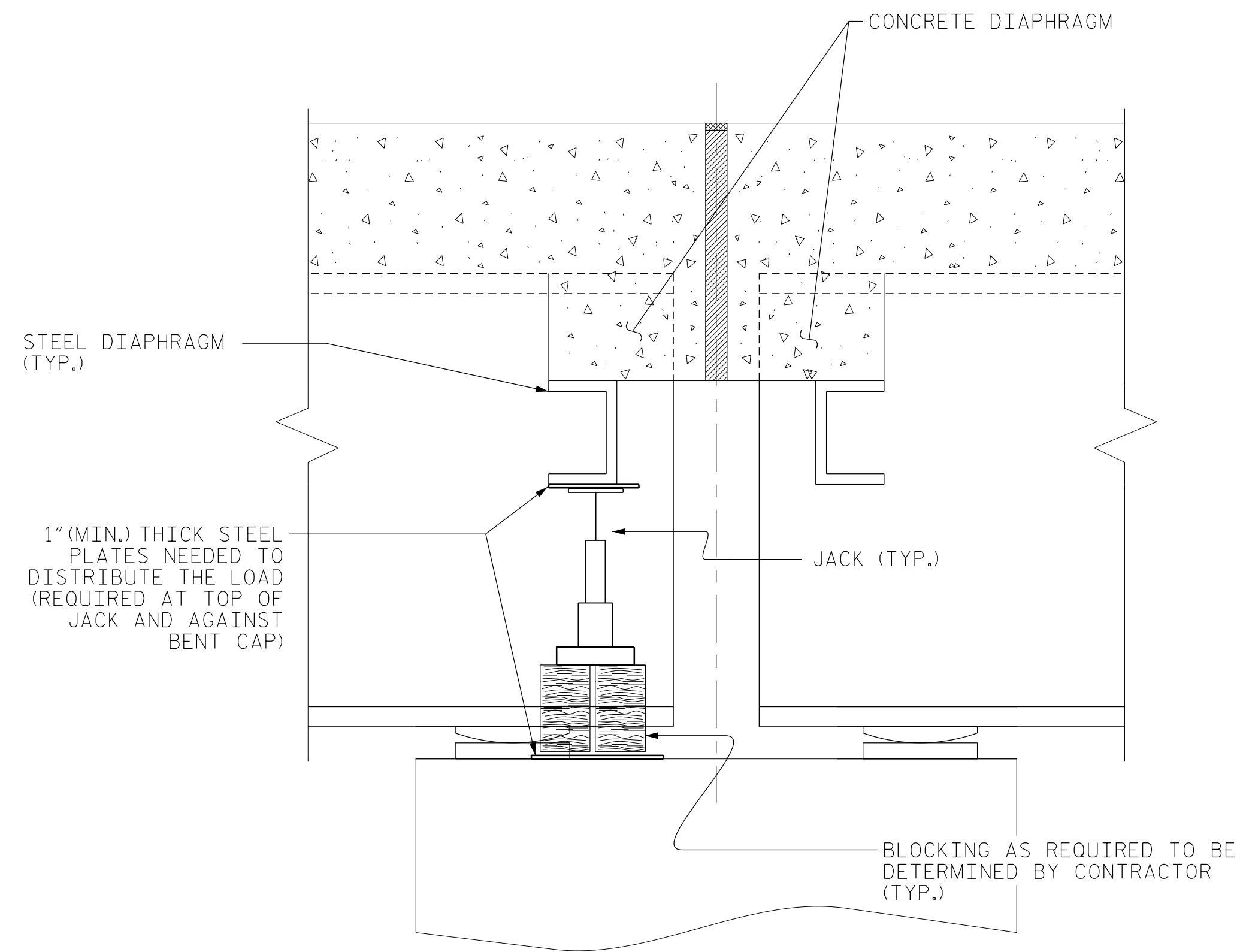

SECTION THRU DIAPHRAGM

**BRIDGE JACKING NOTES:**

THIS DETAIL IS A GENERIC EXAMPLE OF A JACKING SCHEME AND DOES NOT NECESSARILY REPRESENT SPECIFIC CONDITIONS AT A PARTICULAR BRIDGE. ACTUAL BRIDGE GEOMETRIES, DIMENSIONS, AND CONDITIONS MAY DIFFER FROM THIS DETAIL. PRIOR TO BEGINNING WORK, THE CONTRACTOR SHALL INVESTIGATE THE BRIDGES ON THE PROJECT AND DEVELOP A JACKING PLAN TO BE SUBMITTED FOR REVIEW AND APPROVAL. SEE BRIDGE JACKING SPECIAL PROVISION.

PRIOR TO BRIDGE JACKING OPERATIONS, THE ENGINEER AND CONTRACTOR SHALL INSPECT THE STRUCTURE FOR ANY NOTABLE DEFECTS TO THE PRIMARY AND SECONDARY STRUCTURAL MEMBERS. ALL NOTABLE DEFECTS SHALL BE DOCUMENTED AND REPORTED TO THE AREA BRIDGE MAINTENANCE ENGINEER PRIOR TO COMMENCEMENT OF ANY BRIDGE JACKING. THE CONTRACTOR SHALL PROVIDE SAFE AND SUFFICIENT ACCESS TO ALL STRUCTURAL MEMBERS FOR THE ENGINEER TO ESTABLISH PROPER DOCUMENTATION.

PRIOR TO JACKING, THE CONTRACTOR SHALL ENSURE THERE ARE NO OBSTACLES PREVENTING THE BEAM FROM BEING LIFTED.

THE BEAM SHALL BE LIFTED ENOUGH SUCH THAT THE BEAM CLEARS THE BEARINGS AND ALL LOAD IS SUPPORTED BY THE JACKS. AFTER JACKING IS COMPLETE, THE CONTRACTOR SHALL PROVIDE FOR A METHOD TO REMOVE THE JACKS AND SUPPORT THE BEAM FOR DEAD AND LIVE LOAD DURING THE REPAIR OPERATIONS. IF THE JACKS REMAIN IN PLACE DURING THE ENTIRE JACKING AND REPAIR OPERATION, THEY SHALL HAVE MECHANICAL LOCK OFF CAPABILITIES.

IF, DURING THE JACKING PROCESS, OR WHILE THE BEAM IS BEING SUPPORTED, THE BEAM SHIFTS FROM ITS ORIGINAL POSITION, ALL WORK SHALL CEASE AND THE ENGINEER SHALL BE NOTIFIED IMMEDIATELY.

BEARINGS ADJACENT TO THE BEAM BEING JACKED MAY BE LOOSENED TO DECREASE THE RESISTANCE OF THE DECK SLAB DURING JACKING. ALL BEARINGS LOOSENED SHALL BE TIGHTENED BACK AFTER REPAIR OPERATIONS ARE COMPLETED AND THE JACKS AND BLOCKING HAVE BEEN REMOVED.

THE MAXIMUM DIFFERENTIAL BETWEEN ADJACENT BEAMS THAT ARE BEING JACKED IS 1/8".

LOADS PROVIDED IN THE "BRIDGE JACKING TABLE" ARE SHOWN FOR INFORMATIONAL PURPOSES ONLY. THE CONTRACTOR'S ENGINEER SHALL DETERMINE THE EXPECTED LOADS TO BE LIFTED DURING THE BRIDGE JACKING OPERATIONS.

THE CONTRACTOR SHALL SUBMIT WORKING DRAWINGS AND CALCULATIONS OF THE JACKING PROCEDURE(S) SEALED BY A PROFESSIONAL ENGINEER IN THE STATE OF NORTH CAROLINA TO THE ENGINEER FOR APPROVAL PRIOR TO BRIDGE JACKING OPERATIONS.

FOR TYPE I OR TYPE II BRIDGE JACKING, SEE SPECIAL PROVISIONS.

FOR WORKING DRAWING SUBMITTALS, SEE SPECIAL PROVISIONS.

ANY STEEL THAT HAS BEEN WELDED TO THE EXISTING STRUCTURE SHALL REMAIN IN PLACE.

TYPE II BRIDGE JACKING SHALL BE DONE WITH A HYDRUALIC JACKING SYSTEM THAT LIFTS EACH BEAM ALONG ENTIRE SPAN END WITH EQUAL FORCE AND AT AN EQUAL RATE.

THE CONTRACTOR SHALL BE RESPONSIBLE FOR REPAIRING ANY DAMAGE CAUSED TO THE EXISTING STRUCTURE BY BRIDGE JACKING OPERATIONS AT NO ADDITIONAL COST TO THE DEPARTMENT.

BRIDGES: 170171, 170172, 170177, 480006, 480007, 480123, 480124

PROJECT NO. I-5915B

CATAWBA/IREDELL COUNTY

BRIDGE NO. MULTIPLE

<b>BRIDGE NO: 170171</b>					
<b>BRIDGE JACKING TABLE</b>					
SPAN	BEAM(S)	BRIDGE JACKING TYPE	DEAD LOAD (DC+DW) (KIPS)	LL & DL (IMPACT) (DC+DW) (KIPS)	MINIMUM JACK CAPACITY (LL & DL) (TONS)
1&3	INTERIOR	TYPE I	21.8	140.0	100
1&3	EXTERIOR	TYPE I	18.9	88.0	75

<b>BRIDGE NO: 170172</b>					
<b>BRIDGE JACKING TABLE</b>					
SPAN	BEAM(S)	BRIDGE JACKING TYPE	DEAD LOAD (DC+DW) (KIPS)	LL & DL (IMPACT) (DC+DW) (KIPS)	MINIMUM JACK CAPACITY (LL & DL) (TONS)
1&3	INTERIOR	TYPE I	27.1	159.0	100
1&3	EXTERIOR	TYPE I	23.9	101.8	75

<b>BRIDGE NO: 480006</b>					
<b>BRIDGE JACKING TABLE</b>					
SPAN	BEAM(S)	BRIDGE JACKING TYPE	DEAD LOAD (DC+DW) (KIPS)	LL & DL (IMPACT) (DC+DW) (KIPS)	MINIMUM JACK CAPACITY (LL & DL) (TONS)
1-6	INTERIOR	TYPE I	56.5	290.0	165
1-6	EXTERIOR	TYPE I	47.8	229.6	135

<b>BRIDGE NO: 480007</b>					
<b>BRIDGE JACKING TABLE</b>					
SPAN	BEAM(S)	BRIDGE JACKING TYPE	DEAD LOAD (DC+DW) (KIPS)	LL & DL (IMPACT) (DC+DW) (KIPS)	MINIMUM JACK CAPACITY (LL & DL) (TONS)
1&6	INTERIOR	TYPE I	56.5	290.0	165
1&6	EXTERIOR	TYPE I	47.8	229.6	135

<b>BRIDGE NO: 480066</b>					
<b>BRIDGE JACKING TABLE</b>					
SPAN	BEAM(S)	BRIDGE JACKING TYPE	DEAD LOAD (DC+DW) (KIPS)	LL & DL (IMPACT) (DC+DW) (KIPS)	MINIMUM JACK CAPACITY (LL & DL) (TONS)
1&3	INTERIOR	TYPE I	20.6	116.2	80
1&3	EXTERIOR	TYPE I	17.0	89.5	65

<b>BRIDGE NO: 480123</b>					
<b>BRIDGE JACKING TABLE</b>					
SPAN	BEAM(S)	BRIDGE JACKING TYPE	DEAD LOAD (DC+DW) (KIPS)	LL & DL (IMPACT) (DC+DW) (KIPS)	MINIMUM JACK CAPACITY (LL & DL) (TONS)
1&3	INTERIOR	TYPE I	20.6	112.4	75
1&3	EXTERIOR	TYPE I	16.1	86.2	65

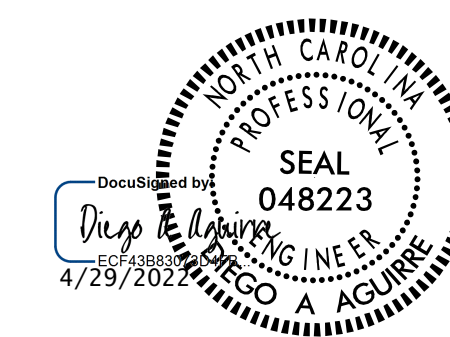

STATE OF NORTH CAROLINA DEPARTMENT OF TRANSPORTATION RALEIGH					
BRIDGE JACKING DETAILS					
REVISIONS					SHEET NO.
NO.	BY:	DATE:	NO.	BY:	DATE:
1			3		
2			4		
					S8
					TOTAL SHEETS 9

DRAWN BY : DIEGO A. AGUIRRE DATE : 01/2022  
 CHECKED BY : JACOB H. DUKE DATE : 01/2022  
 DESIGN ENGINEER OF RECORD: DIEGO A. AGUIRRE DATE : 01/2022

4/21/2022  
I5915B\_SMU\_UK01.dgn  
daquirre

DOCUMENT NOT CONSIDERED FINAL UNLESS ALL SIGNATURES COMPLETED



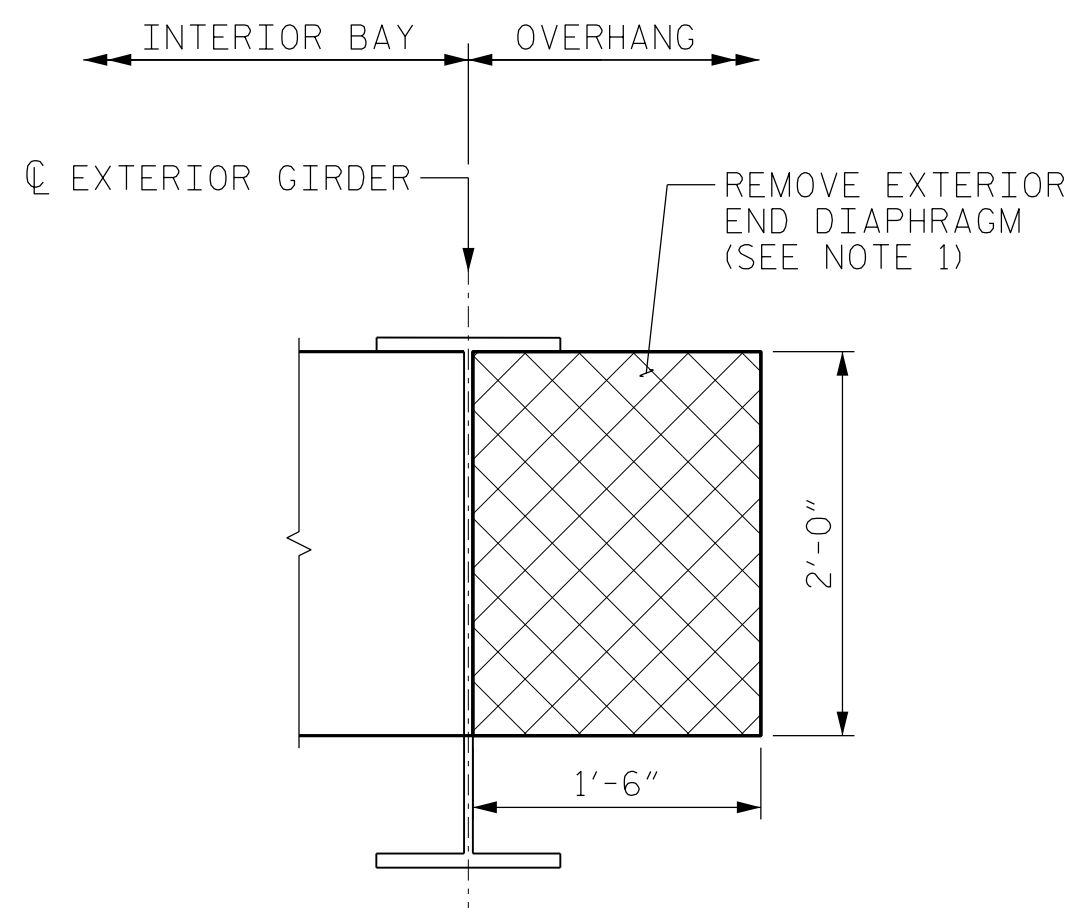

DETAIL "RD"  
REMOVE DIAPHRAGMS  
(APPLIES TO END DIAPHRAGMS AT OVERHANGS)  
(DECK NOT SHOWN FOR CLARITY)

CONCRETE DIAPHRAGM REPAIRS

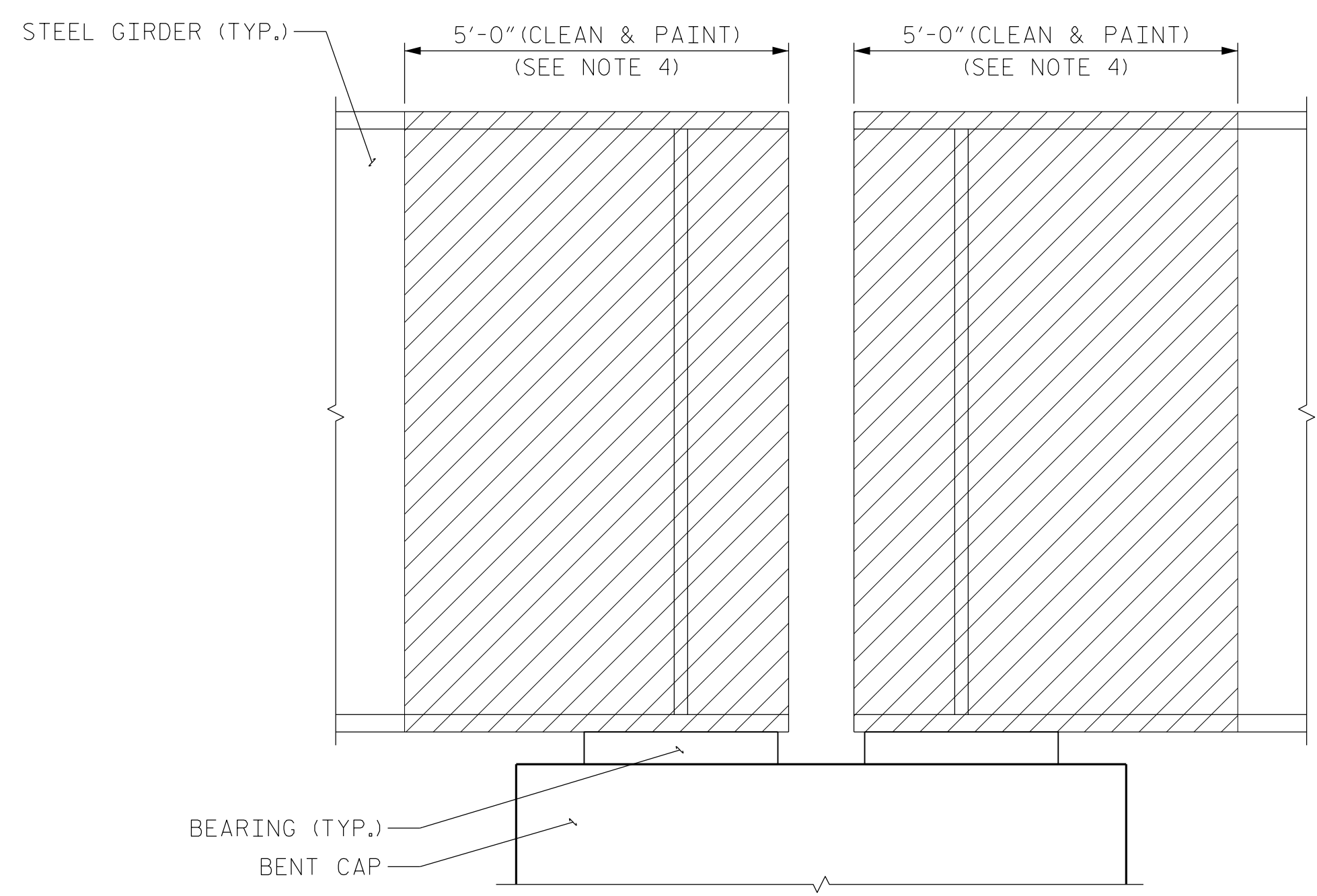

CLEAN AND PAINT GIRDER ENDS  
(GIRDERS AT INTERMEDIATE BENTS SHOWN, SIMILAR AT END BENTS)  
(DECK NOT SHOWN FOR CLARITY)

NOTES:

1. AFTER REMOVAL OF EXTERIOR END DIAPHRAGMS CUT ANY EXPOSED REBAR FLUSH WITH THE DECK. COAT THE REMAINING EXPOSED REBAR WITH EPOXY.
2. ALL LABOR, TOOLS, AND MATERIALS REQUIRED FOR THE REMOVAL OF END DIAPHRAGMS SHALL BE INCIDENTAL TO THE PAY ITEM OF "CONCRETE REPAIRS". NO ADDITIONAL PAYMENTS WILL BE MADE FOR THIS WORK.
3. INTERIOR END DIAPHRAGM REPAIRS ARE CONSIDERED "CONCRETE REPAIRS". QUANTITIES ARE INCLUDED IN THE "SUPERSTRUCTURE REPAIRS" SHEETS.
4. CLEAN AND PAINT EXISTING GIRDER ENDS TO THE LIMITS SHOWN HEREIN AND IN ACCORDANCE WITH THE SPECIAL PROVISIONS FOR ZONE PAINTING OF EXISTING STRUCTURE.
5. FOR ZONE PAINTING OF EXISTING STRUCTURE, SEE SPECIAL PROVISIONS.

BRIDGES: 480006, 480007, 480051, 480054  
480065, 480066, 480072, 480073  
480096, 480102.

PROJECT NO. I-5915B  
CATAWBA & IREDELL COUNTY  
BRIDGE NO. MULTIPLE

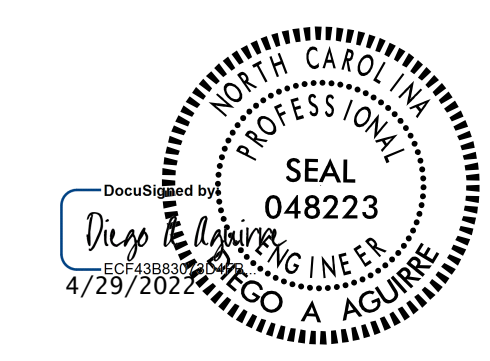

STATE OF NORTH CAROLINA DEPARTMENT OF TRANSPORTATION RALEIGH						SHEET NO.
MISCELLANEOUS REPAIRS						S9
REVISIONS						TOTAL SHEETS
NO.	BY:	DATE:	NO.	BY:	DATE:	9
1			3			
2			4			

DRAWN BY : DIEGO A. AGUIRRE DATE : 01/2022  
CHECKED BY : SAMUEL L. CULLUM DATE : 01/2022  
DESIGN ENGINEER OF RECORD: DIEGO A. AGUIRRE DATE : 01/2022

DOCUMENT NOT CONSIDERED  
FINAL UNLESS ALL  
SIGNATURES COMPLETED

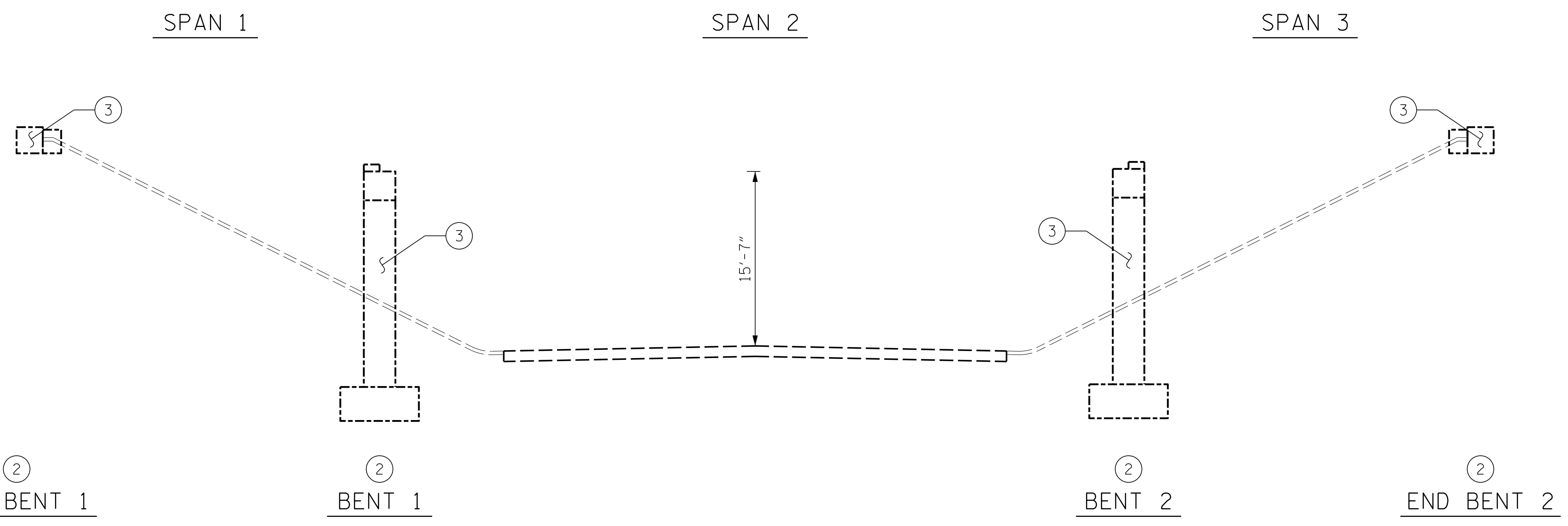

- SCOPE LEGEND:**
- ① CLEAR SHOULDERS OF DEBRIS AND VEGETATION
  - ② SUBSTRUCTURE CONCRETE REPAIRS
  - ③ SUBSTRUCTURE EPOXY RESIN INJECTION
  - ④ APPROACH ROADWAY MILLING AND RESURFACING
  - ⑤ DECK REPAIRS

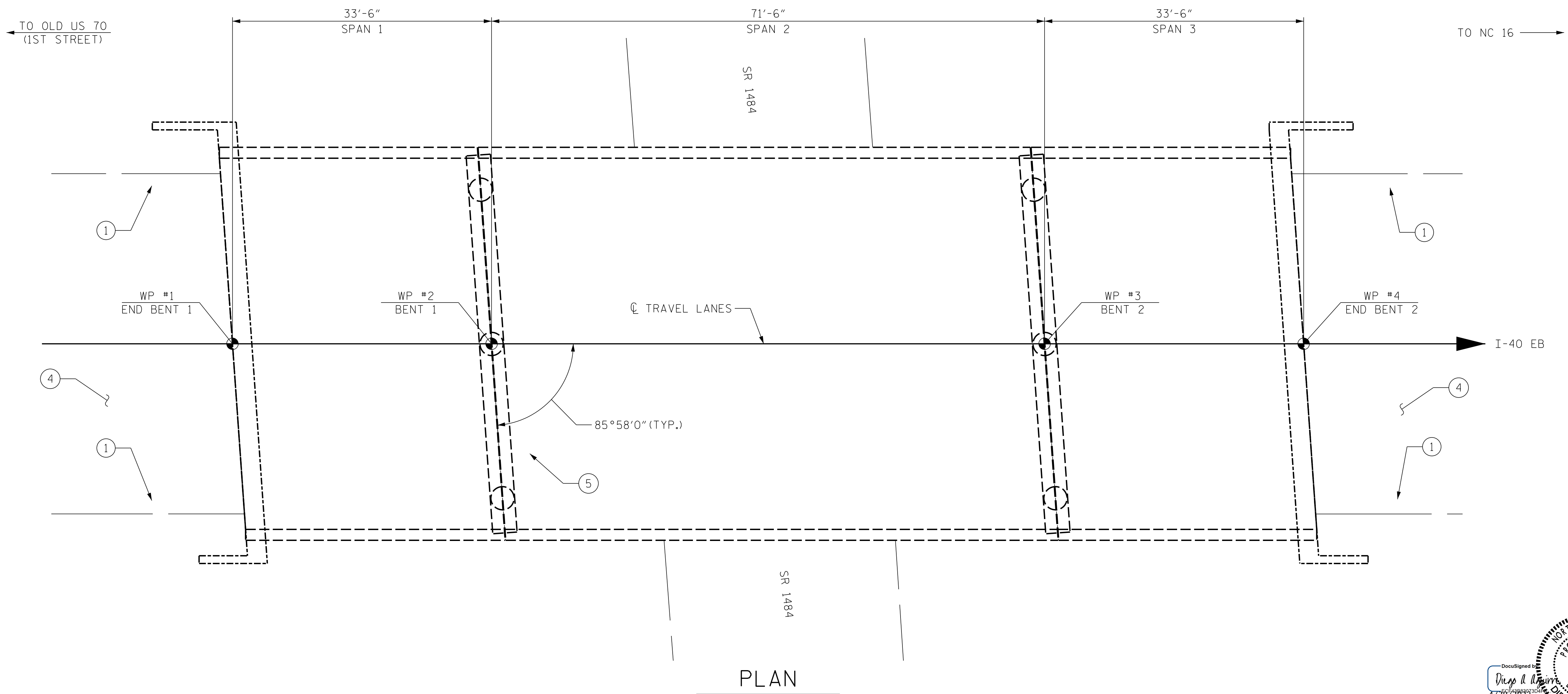

I HEREBY CERTIFY THAT THIS STRUCTURE WAS REHABILITATED ACCORDING TO THESE PLANS OR AS NOTED THEREIN.

RESIDENT ENGINEER \_\_\_\_\_ DATE \_\_\_\_\_

PROJECT NO. I-5915B  
CATAWBA COUNTY  
 BRIDGE NO. 170171

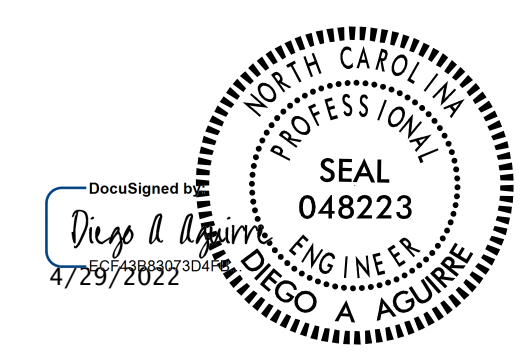

**KCA**  
**KISINGER CAMPO & ASSOCIATES**  
 301 FAYETTEVILLE ST., SUITE 1500  
 RALEIGH, NC 27601 (919) 882-7839  
 NC FIRM LICENSE: C-1506

STATE OF NORTH CAROLINA  
 DEPARTMENT OF TRANSPORTATION  
 RALEIGH  
**GENERAL DRAWING**  
 FOR BRIDGE ON I-40 EB  
 OVER SR 1484

**NOTES:**

GENERAL DRAWING INFORMATION IS TAKEN FROM THE ORIGINAL PLANS AND THE MOST UP TO DATE ROUTINE INSPECTION REPORT DATED 04/16/2021.

DRAWN BY : DIEGO A. AGUIRRE DATE : 01/2022  
 CHECKED BY : FIDEL L. FLORES DATE : 01/2022  
 DESIGN ENGINEER OF RECORD: DIEGO A. AGUIRRE DATE : 01/2022

DOCUMENT NOT CONSIDERED FINAL UNLESS ALL SIGNATURES COMPLETED

REVISIONS						SHEET NO.
NO.	BY:	DATE:	NO.	BY:	DATE:	
1			3			S1-1
2			4			TOTAL SHEETS 7

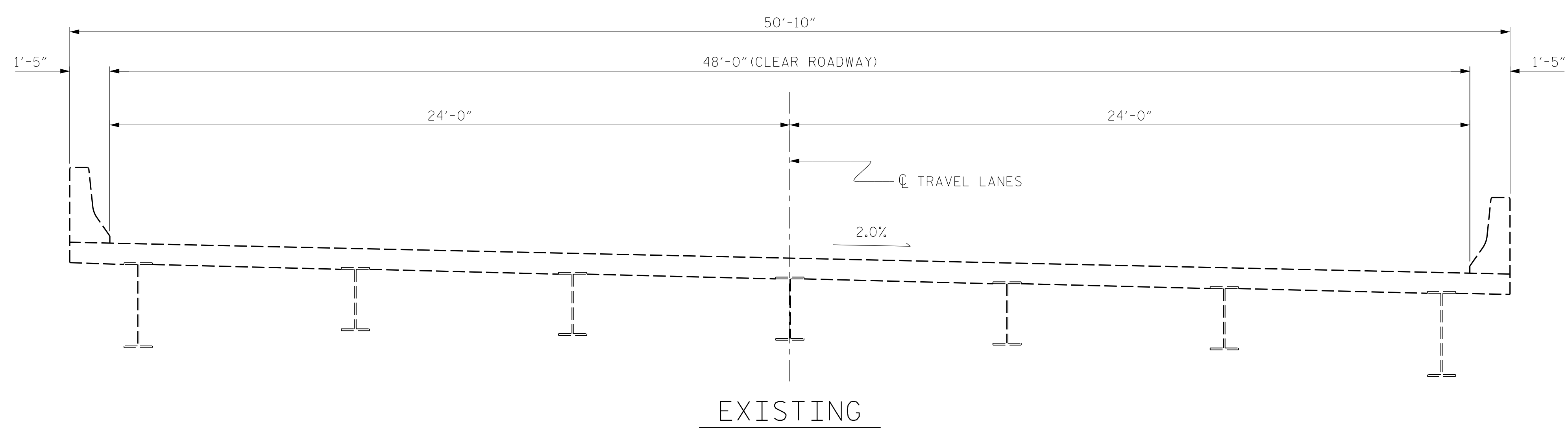

PROJECT NO. I-5915B  
CATAWBA COUNTY  
 BRIDGE NO. 170171

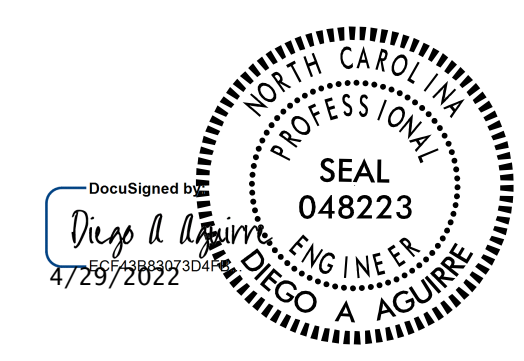

STATE OF NORTH CAROLINA DEPARTMENT OF TRANSPORTATION RALEIGH						SHEET NO.
TYPICAL SECTION						S1-2
REVISIONS						TOTAL SHEETS
NO.	BY:	DATE:	NO.	BY:	DATE:	7
1			3			
2			4			

DRAWN BY : DIEGO A. AGUIRRE DATE : 01/2022  
 CHECKED BY : FIDEL L. FLORES DATE : 01/2022  
 DESIGN ENGINEER OF RECORD: DIEGO A. AGUIRRE DATE : 01/2022

DOCUMENT NOT CONSIDERED  
 FINAL UNLESS ALL  
 SIGNATURES COMPLETED



# AS-BUILT REPAIR QUANTITY TABLE

## SUPERSTRUCTURE REPAIRS

	SPAN 1				SPAN 2				SPAN 3			
	ESTIMATE		ACTUAL		ESTIMATE		ACTUAL		ESTIMATE		ACTUAL	
	AREA	VOLUME	AREA	VOLUME	AREA	VOLUME	AREA	VOLUME	AREA	VOLUME	AREA	VOLUME
SHOTCRETE REPAIR AREA (SCR)	-- SF	-- CF			-- SF	-- CF			1.9 SF	0.7 CF		
	ESTIMATE		ACTUAL		ESTIMATE		ACTUAL		ESTIMATE		ACTUAL	
CLASS II REPAIR	-- SY				0.1 SY				-- SY			

**LEGEND:** \_\_\_\_\_

SCR SHOTCRETE REPAIR AREA

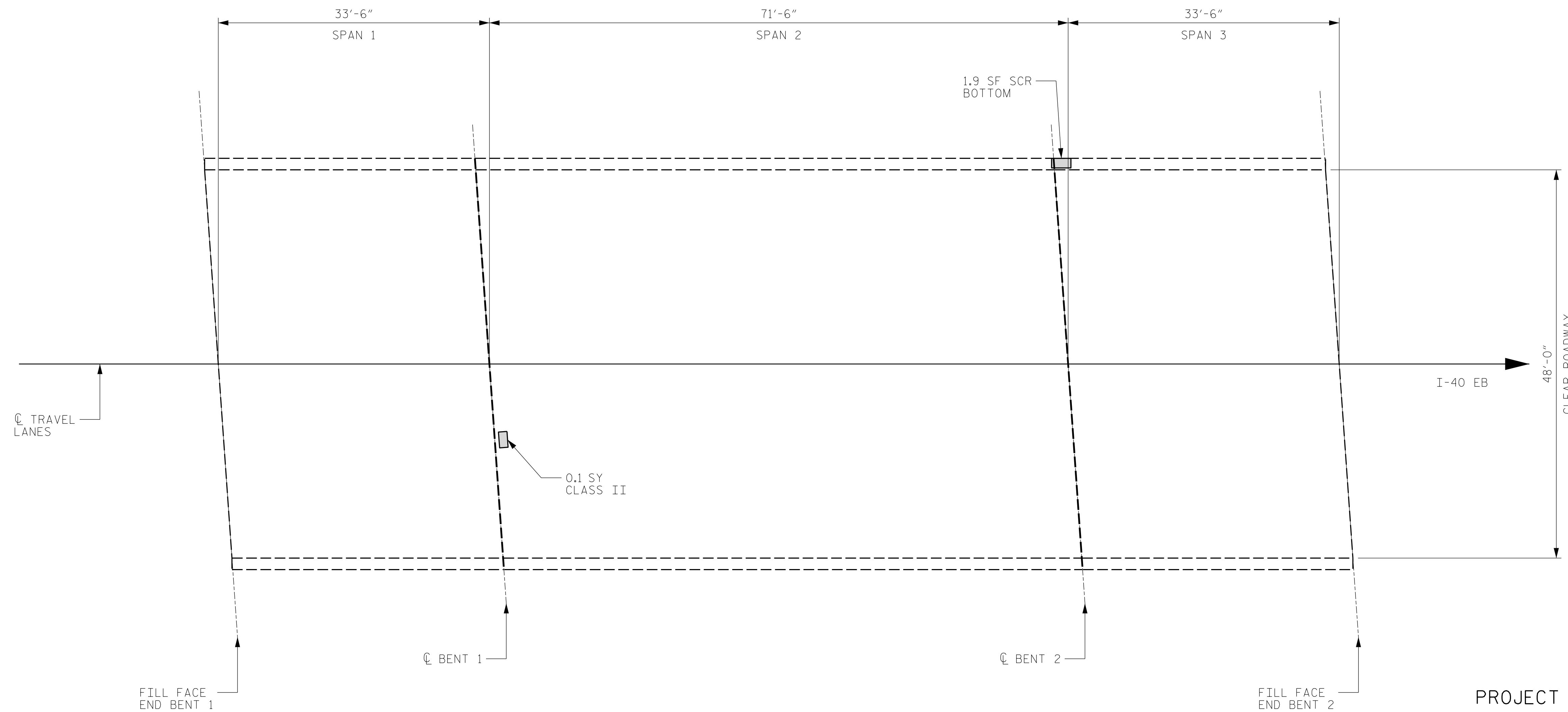

PLAN

PROJECT NO. I-5915B  
CATAWBA COUNTY  
 BRIDGE NO. 170171

**NOTES:**

PRIOR TO SURFACE PREPARATION, REMOVE ALL LOOSE, DISINTEGRATED, UNSOUND OR CONTAMINATED CONCRETE FROM THE BRIDGE DECK. FOR CONCRETE FOR DECK REPAIR, SEE SPECIAL PROVISIONS.

FOR SCARIFYING BRIDGE DECK, SEE OVERLAY SURFACE PREPARATION SPECIAL PROVISION.

REPAIR LOCATIONS AND ESTIMATED QUANTITIES ARE GIVEN WITH THE BEST INFORMATION AVAILABLE. IF ADDITIONAL REPAIRS NOT SHOWN ON THE DRAWINGS ARE DEEMED NECESSARY BY THE ENGINEER, THE ENGINEER WILL NOTE ON THE DRAWINGS THE APPROXIMATE LOCATIONS AND DESCRIPTION OF THE REPAIRS AND ADJUST THE ACTUAL QUANTITIES ENTERED INTO THE AS-BUILT REPAIR QUANTITY TABLE.

DEFECTS (SEE PLAN CALLOUT FOR DETAILS)

DRAWN BY : ALLEN J. MCSWAIN DATE : 01/2022  
 CHECKED BY : FIDEL L. FLORES DATE : 01/2022  
 DESIGN ENGINEER OF RECORD: DIEGO A. AGUIRRE DATE : 01/2022

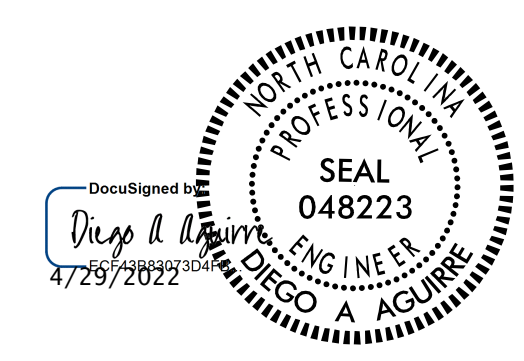

STATE OF NORTH CAROLINA  
 DEPARTMENT OF TRANSPORTATION  
 RALEIGH

**PLAN OF SPANS  
 DECK REPAIRS**

REVISIONS						SHEET NO.
NO.	BY:	DATE:	NO.	BY:	DATE:	
1			3			S1-3
2			4			TOTAL SHEETS 7

DOCUMENT NOT CONSIDERED FINAL UNLESS ALL SIGNATURES COMPLETED

# AS-BUILT REPAIR QUANTITY TABLE

	ESTIMATE	ACTUAL
INCIDENTAL MILLING	490 SY	
ASPHALT CONCRETE SURFACE COURSE, TYPE S9.5C	41 TON	
ASPHALT BINDER FOR PLANT MIX	2.5 TON	

## NOTES:

INCIDENTAL MILLING - EXISTING APPROACH ASPHALT PAVEMENT TO BE MILLED AS NECESSARY TO ATTAIN MINIMUM 1/2" DEPTH OF NEW ASPHALT PAVEMENT. NEW ASPHALT PAVEMENT SHALL BE OF THICKNESS NECESSARY TO PROVIDE A SMOOTH TRANSITION BETWEEN THE ROADWAY AND THE BRIDGE DECK. THE NEW ASPHALT PAVEMENT THICKNESS MAY EXCEED 1/2" DUE TO SETTLEMENT OF THE EXISTING APPROACH.

FOR NEW ASPHALT PLACEMENT, SEE STANDARD SPECIFICATIONS.

GRADE MAY BE ADJUSTED BY THE ENGINEER TO ENSURE PROPER TIE-IN AT THE END BENTS.

**C1** PROPOSED VARIABLE DEPTH ASPHALT CONCRETE SURFACE COURSE, TYPE S9.5C AT AN AVERAGE RATE OF 112 LBS. PER SQ. YD. PER 1" DEPTH. TO BE PLACED IN LAYERS NOT LESS THAN 1" OR GREATER THAN 2" IN DEPTH.

INCIDENTAL MILLING

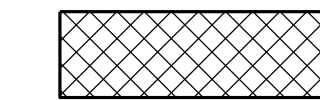

ASPHALT CONCRETE SURFACE COURSE, TYPE S9.5C (C1)

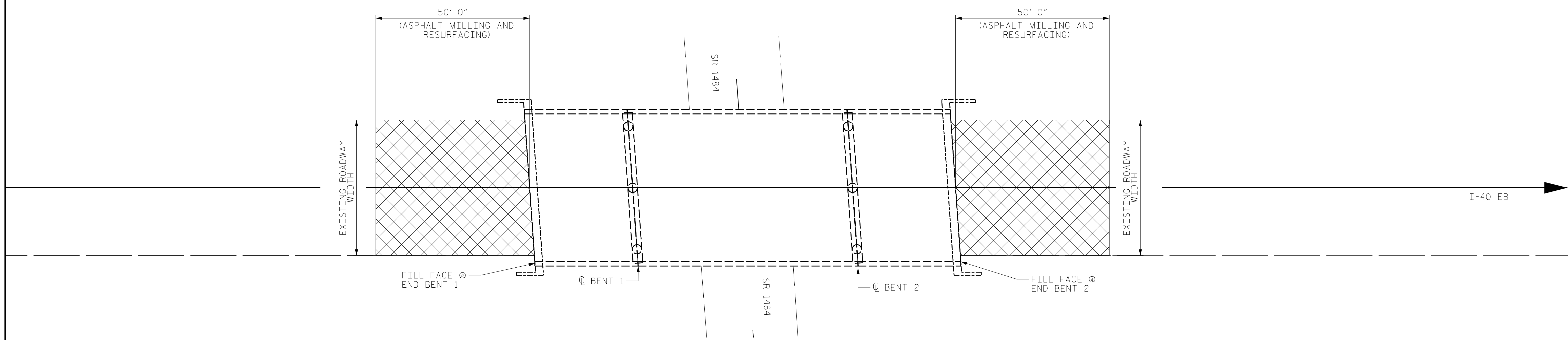
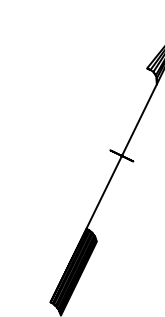

PLAN

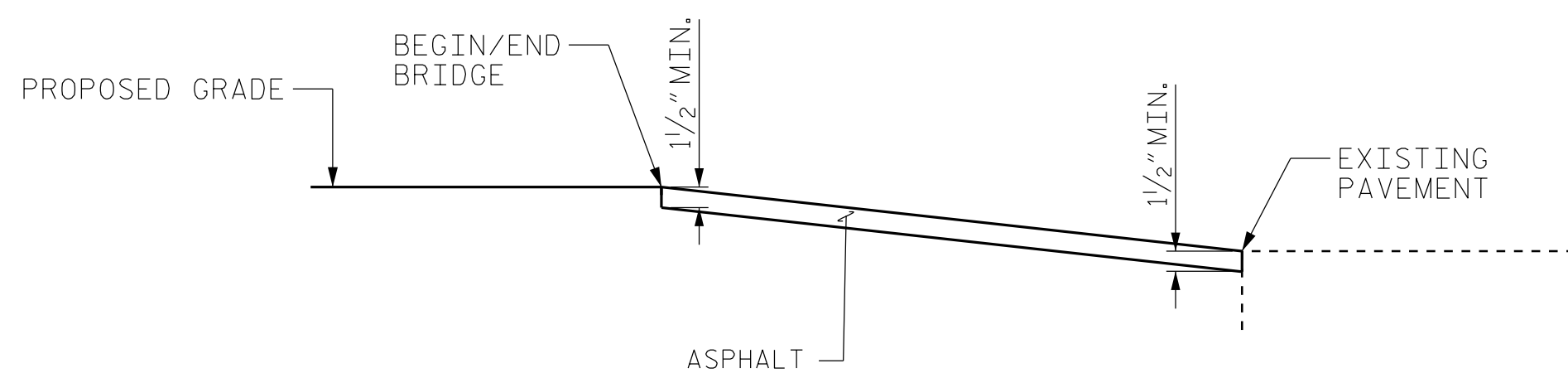

PAVEMENT KEY-IN DETAIL FOR BOTH END BENTS

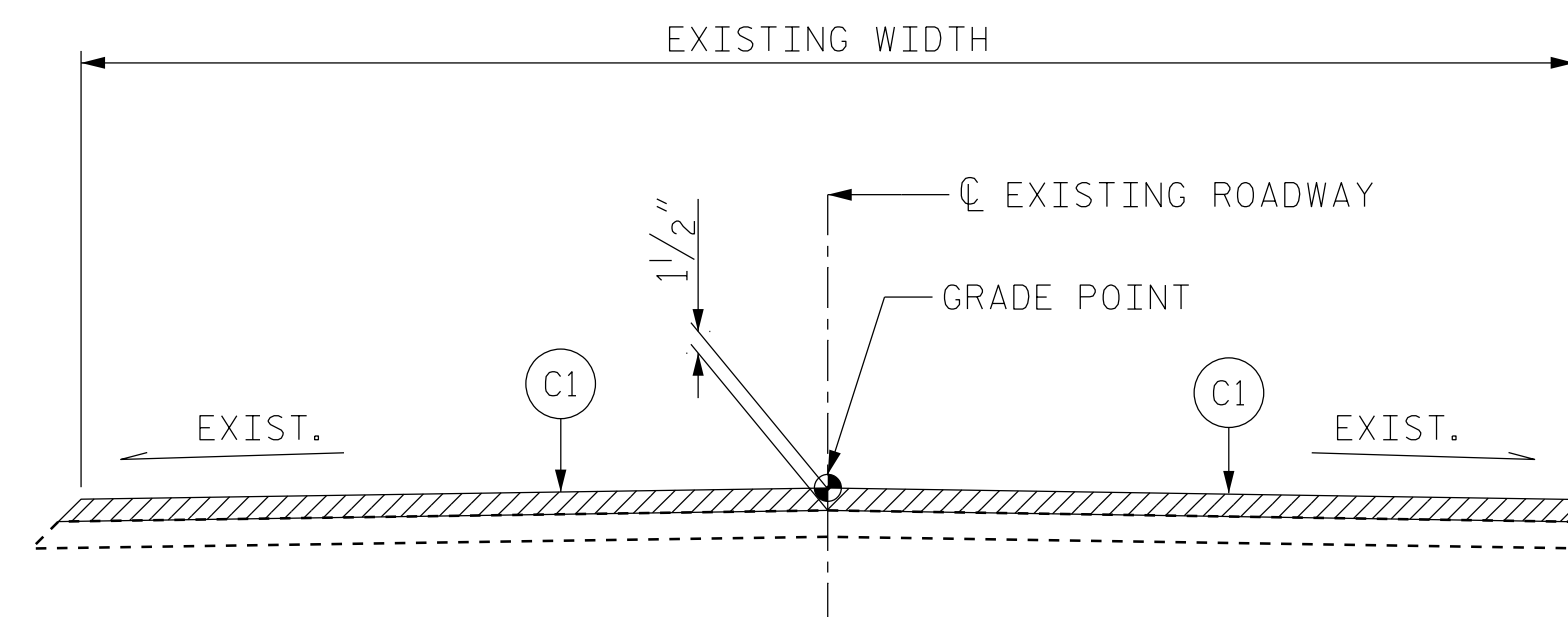

ROADWAY SECTION  
BEGIN/END BRIDGE

PROJECT NO. I-5915B  
CATAWBA COUNTY  
 BRIDGE NO. 170171



**KCA**  
**KISINGER CAMPO & ASSOCIATES**  
 301 FAYETTEVILLE ST., SUITE 1500  
 RALEIGH, NC 27601 (919) 882-7839  
 NC FIRM LICENSE: C-1506



STATE OF NORTH CAROLINA  
 DEPARTMENT OF TRANSPORTATION  
 RALEIGH  
**APPROACH ROADWAY  
 MILLING AND RESURFACING**

DRAWN BY : FIDEL L. FLORES DATE : 01/2022  
 CHECKED BY : JACOB H. DUKE DATE : 01/2022  
 DESIGN ENGINEER OF RECORD: DIEGO A. AGUIRRE DATE : 01/2022

4/21/2022  
 I5915B\_SMU\_AR01.170171.dgn  
 daquirre

DOCUMENT NOT CONSIDERED  
 FINAL UNLESS ALL  
 SIGNATURES COMPLETED

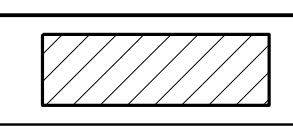
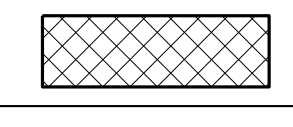
REVISIONS						SHEET NO.
NO.	BY:	DATE:	NO.	BY:	DATE:	
1			3			S1-4
2			4			TOTAL SHEETS 7

LEGEND	
	CONCRETE REPAIR AREA (CR)
	SHOTCRETE REPAIR AREA (SCR)
	EPOXY RESIN INJECTION (ERI)

	AS-BUILT REPAIR QUANTITY TABLE			
	ESTIMATE		ACTUAL	
SHOTCRETE REPAIRS	AREA SQ. FT.	VOLUME CU. FT.	AREA SQ. FT.	VOLUME CU. FT.
	CAP/BACKWALL	-	-	
COLUMN/PILE	-	-		
CONCRETE REPAIRS	AREA SQ. FT.	VOLUME CU. FT.	AREA SQ. FT.	VOLUME CU. FT.
	CAP	-	-	
EPOXY RESIN INJECTION	LIN. FT.		LIN. FT.	
	CAP/BACKWALL	105.5		
COLUMN/PILE	-			

VALUES IN CHART REPRESENT ESTIMATED REPAIR TOTALS AFTER REMOVAL OF UNSOUND CONCRETE. MINIMUM OF 1" BEHIND REBAR AND MINIMUM 2" CLEARANCE TO SAWCUT. FOR REPAIR DETAILS, SEE "CONCRETE RESTORATION DETAILS" SHEETS.

**NOTES:**  
 REPAIR LOCATIONS AND ESTIMATED QUANTITIES ARE GIVEN WITH THE BEST INFORMATION AVAILABLE. IF ADDITIONAL REPAIRS NOT SHOWN ON THE DRAWINGS ARE DEEMED NECESSARY BY THE ENGINEER, THE ENGINEER WILL NOTE ON THE DRAWINGS THE APPROXIMATE LOCATIONS AND DESCRIPTION OF THE REPAIRS AND ADJUST THE ACTUAL QUANTITIES ENTERED INTO THE TABLE ABOVE.

CRACKING LOCATIONS AND QUANTITIES FOR LOCATIONS DESCRIBED AS "SCATTERED THROUGHOUT" IN THE INSPECTION REPORT ARE BASED ON THE BEST INFORMATION AVAILABLE. THE ENGINEER AND CONTRACTOR SHALL IDENTIFY AND REPAIR ALL CRACKS  $\geq 1/16"$  AS DESCRIBED IN THE SPECIAL PROVISIONS AT EACH BENT.

AVERAGE CONCRETE COVER IS EXPECTED TO BE FROM 2" TO 3" ON THE CAP AND FROM 1 1/2" TO 2" ON THE PILES. ACTUAL CONCRETE COVER SHALL BE DETERMINED BY THE CONTRACTOR AND PRESENTED TO THE ENGINEER PRIOR TO BEGINNING EXCAVATION/ DEMOLITION.

FOR CONCRETE AND SHOTCRETE REPAIRS, SEE "CONCRETE RESTORATION DETAILS" SHEETS.

SHOTCRETE REPAIRS MAY BE REPLACED WITH CONCRETE REPAIRS WITH THE APPROVAL OF THE ENGINEER.

REPAIRS TO THE BENT CAP MAY REQUIRE BRIDGE JACKING. FOR BRIDGE JACKING, SEE SPECIAL PROVISIONS.

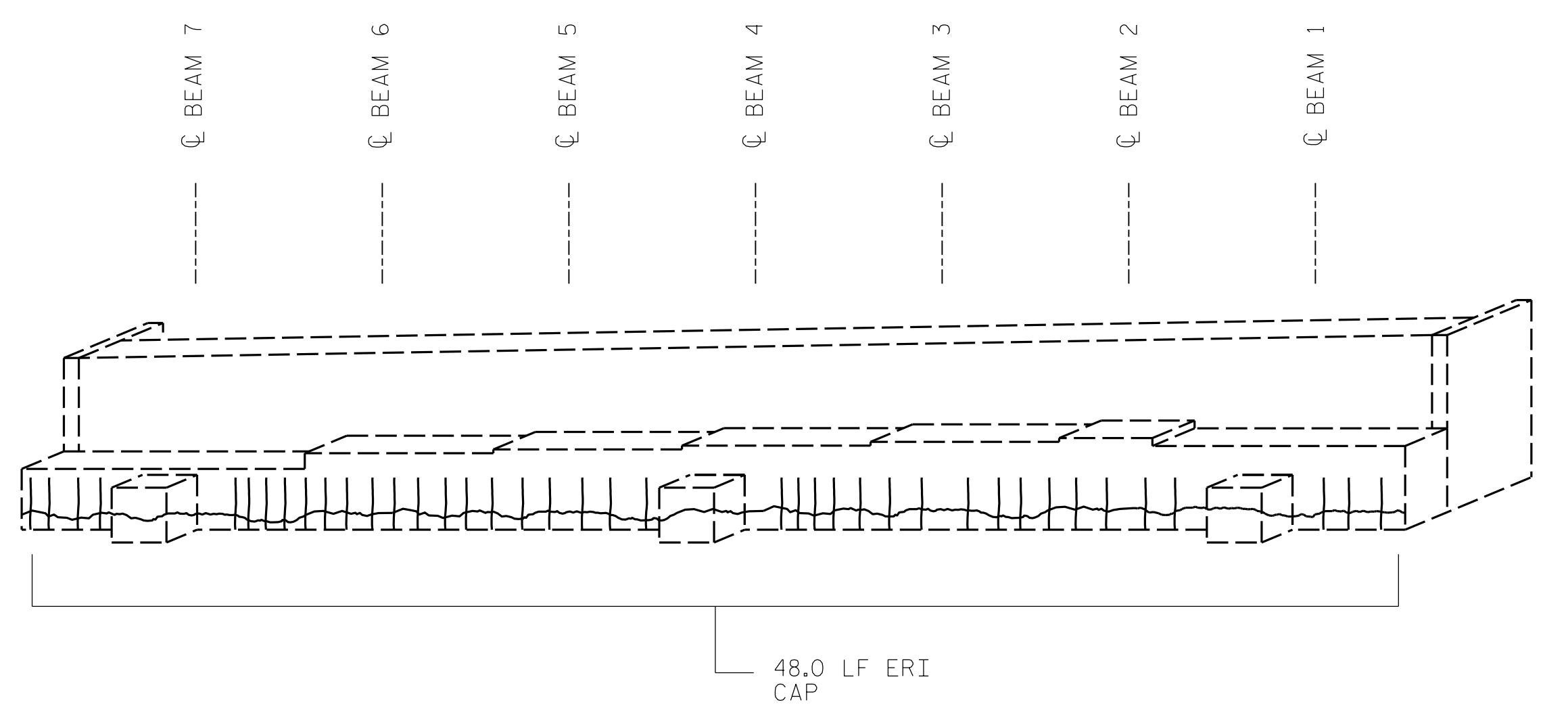

END BENT 1  
(EAST FACE)

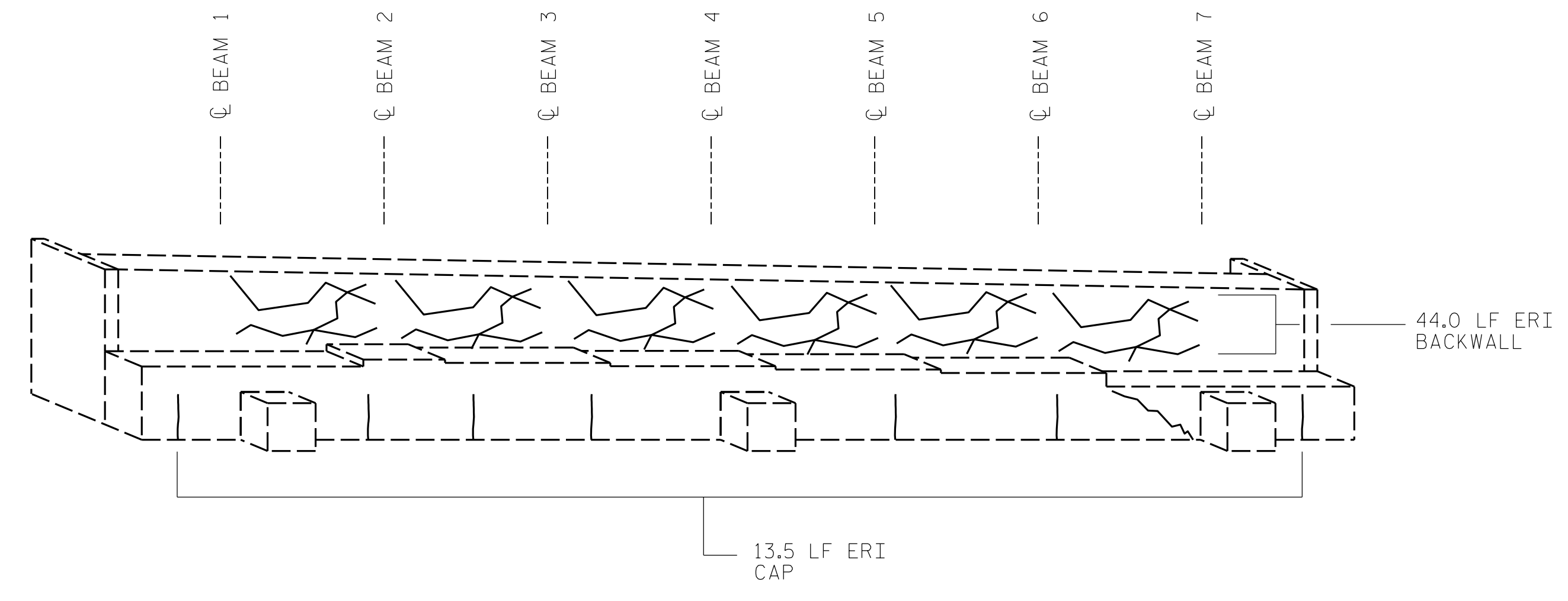

END BENT 2  
(WEST FACE)

PROJECT NO. I-5915B  
CATAWBA COUNTY  
 BRIDGE NO. 170171

SHEET 1 OF 3

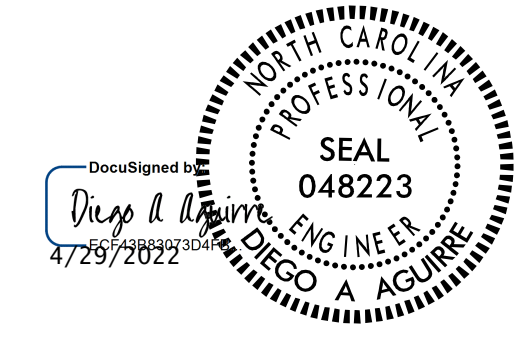

STATE OF NORTH CAROLINA DEPARTMENT OF TRANSPORTATION RALEIGH					
SUBSTRUCTURE REPAIRS					
END BENTS 1 & 2					
REVISIONS					SHEET NO.
NO.	BY:	DATE:	NO.	BY:	DATE:
1			3		
2			4		
					S1-5
					TOTAL SHEETS 7

DRAWN BY : ALLEN J. MCSWAIN DATE : 01/2022  
 CHECKED BY : FIDEL L. FLORES DATE : 01/2022  
 DESIGN ENGINEER OF RECORD: DIEGO A. AGUIRRE DATE : 01/2022

DOCUMENT NOT CONSIDERED FINAL UNLESS ALL SIGNATURES COMPLETED



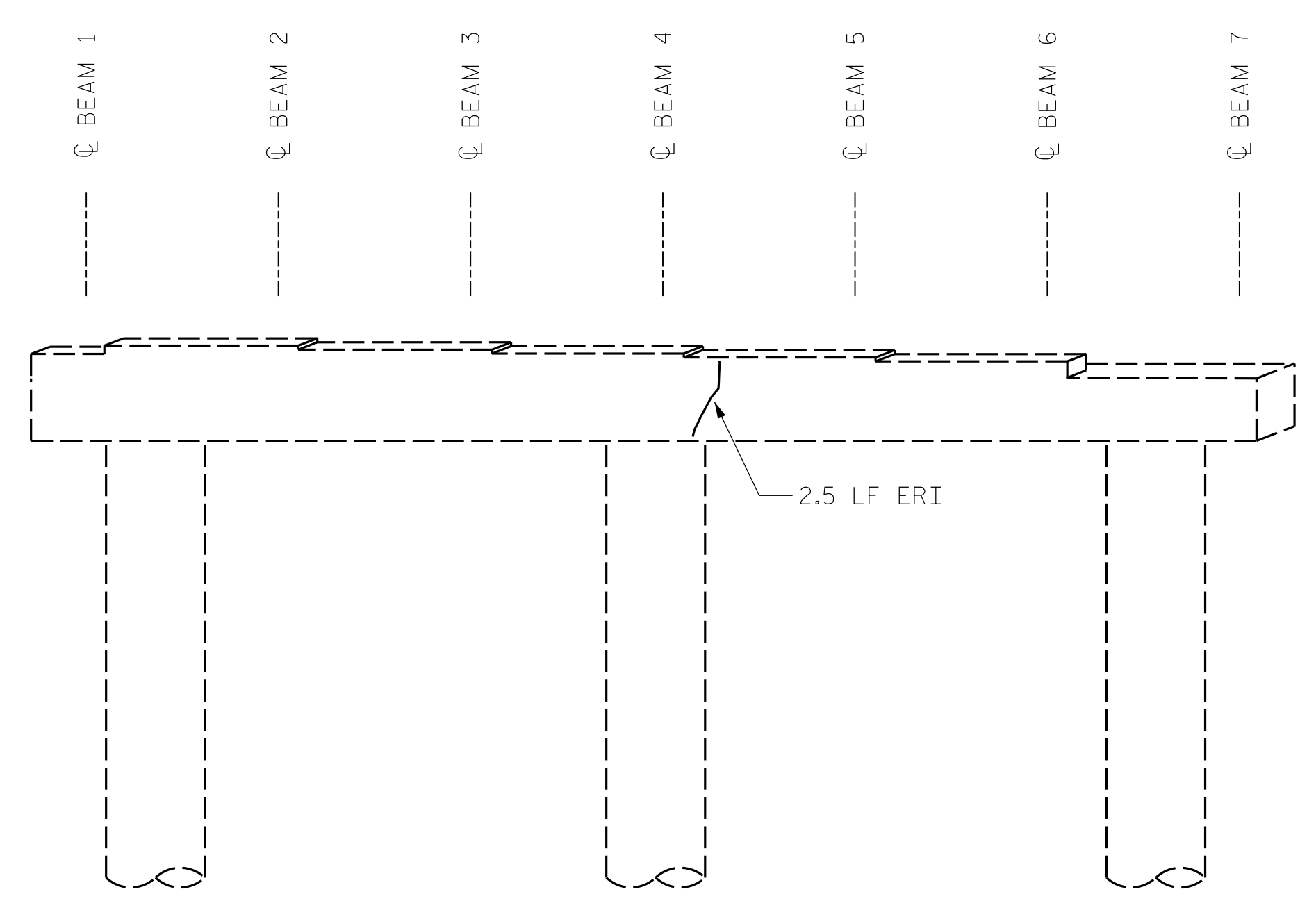

BENT 1  
(WEST FACE)

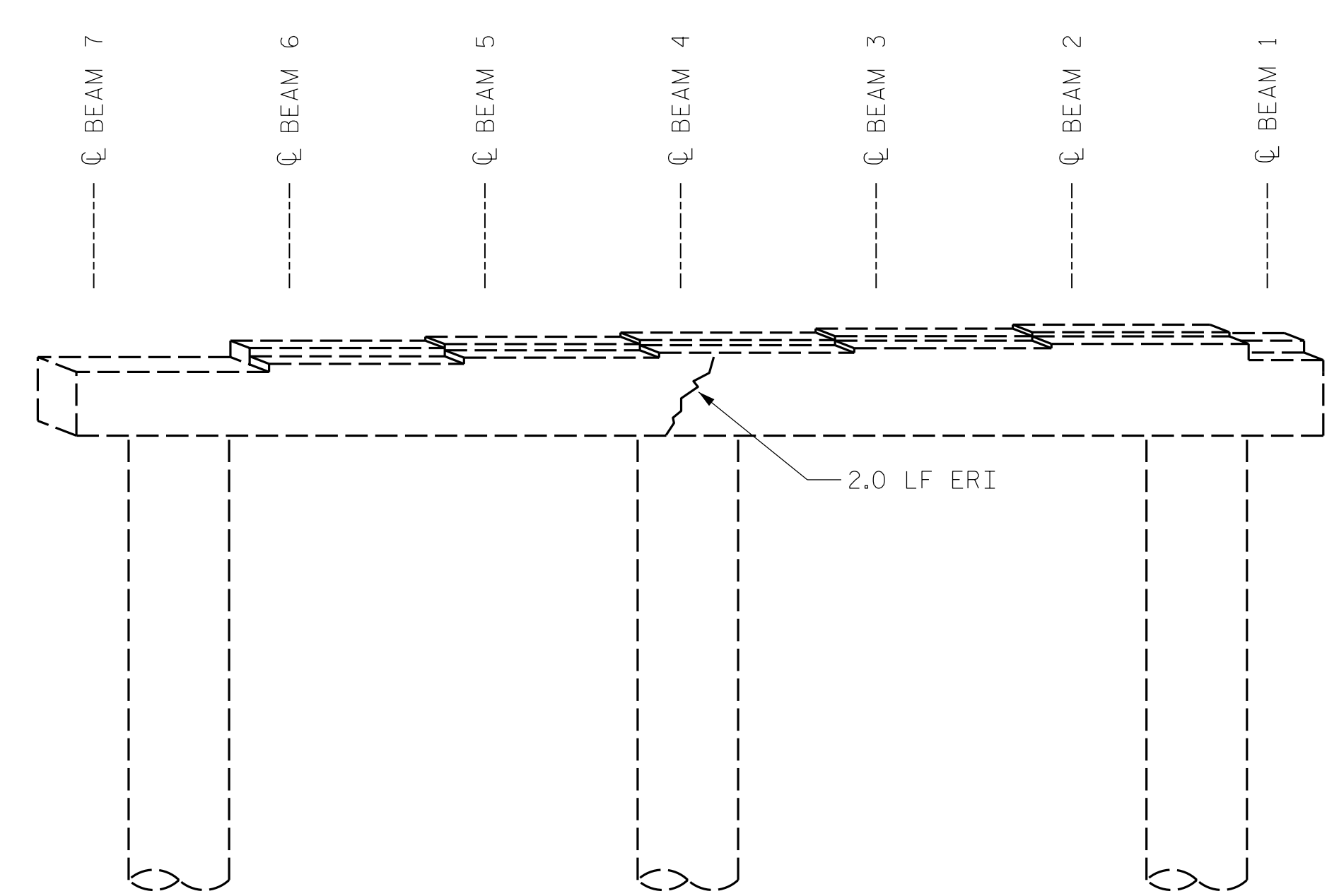

BENT 1  
(EAST FACE)

LEGEND	
	CONCRETE REPAIR AREA (CR)
	SHOTCRETE REPAIR AREA (SCR)
	EPOXY RESIN INJECTION (ERI)

	AS-BUILT REPAIR QUANTITY TABLE			
	ESTIMATE		ACTUAL	
SHOTCRETE REPAIRS	AREA SQ. FT.	VOLUME CU. FT.	AREA SQ. FT.	VOLUME CU. FT.
CAP/BACKWALL	-	-		
COLUMN/PILE	-	-		
CONCRETE REPAIRS	AREA SQ. FT.	VOLUME CU. FT.	AREA SQ. FT.	VOLUME CU. FT.
CAP	-	-		
EPOXY RESIN INJECTION	LIN. FT.		LIN. FT.	
CAP/BACKWALL	4.5			
COLUMN/PILE	-			

VALUES IN CHART REPRESENT ESTIMATED REPAIR TOTALS AFTER REMOVAL OF UNSOUND CONCRETE. MINIMUM OF 1" BEHIND REBAR AND MINIMUM 2" CLEARANCE TO SAWCUT. FOR REPAIR DETAILS, SEE "CONCRETE RESTORATION DETAILS" SHEETS.

**NOTES:**  
REPAIR LOCATIONS AND ESTIMATED QUANTITIES ARE GIVEN WITH THE BEST INFORMATION AVAILABLE. IF ADDITIONAL REPAIRS NOT SHOWN ON THE DRAWINGS ARE DEEMED NECESSARY BY THE ENGINEER, THE ENGINEER WILL NOTE ON THE DRAWINGS THE APPROXIMATE LOCATIONS AND DESCRIPTION OF THE REPAIRS AND ADJUST THE ACTUAL QUANTITIES ENTERED INTO THE TABLE ABOVE.

CRACKING LOCATIONS AND QUANTITIES FOR LOCATIONS DESCRIBED AS "SCATTERED THROUGHOUT" IN THE INSPECTION REPORT ARE BASED ON THE BEST INFORMATION AVAILABLE. THE ENGINEER AND CONTRACTOR SHALL IDENTIFY AND REPAIR ALL CRACKS  $\geq 1/16"$  AS DESCRIBED IN THE SPECIAL PROVISIONS AT EACH BENT.

AVERAGE CONCRETE COVER IS EXPECTED TO BE FROM 2" TO 3" ON THE CAP AND FROM 1 1/2" TO 2" ON THE PILES. ACTUAL CONCRETE COVER SHALL BE DETERMINED BY THE CONTRACTOR AND PRESENTED TO THE ENGINEER PRIOR TO BEGINNING EXCAVATION/ DEMOLITION.

FOR CONCRETE AND SHOTCRETE REPAIRS, SEE "CONCRETE RESTORATION DETAILS" SHEETS.

SHOTCRETE REPAIRS MAY BE REPLACED WITH CONCRETE REPAIRS WITH THE APPROVAL OF THE ENGINEER.

REPAIRS TO THE BENT CAP MAY REQUIRE BRIDGE JACKING. FOR BRIDGE JACKING, SEE SPECIAL PROVISIONS.

PROJECT NO. I-5915B  
CATAWBA COUNTY  
BRIDGE NO. 170171

SHEET 2 OF 3

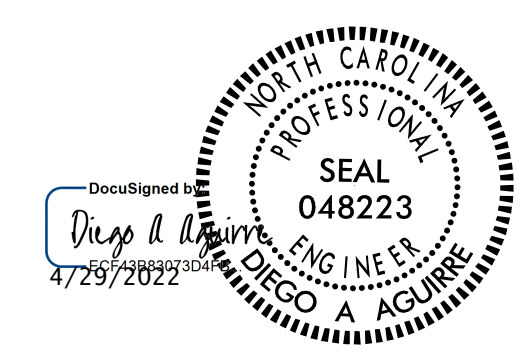

STATE OF NORTH CAROLINA  
DEPARTMENT OF TRANSPORTATION  
RALEIGH  
**SUBSTRUCTURE REPAIRS**  
BENT 1

DRAWN BY : ALLEN J. MCSWAIN DATE : 01/2022  
CHECKED BY : FIDEL L. FLORES DATE : 01/2022  
DESIGN ENGINEER OF RECORD: DIEGO A. AGUIRRE DATE : 01/2022

DOCUMENT NOT CONSIDERED FINAL UNLESS ALL SIGNATURES COMPLETED

REVISIONS						SHEET NO.
NO.	BY:	DATE:	NO.	BY:	DATE:	
1			3			S1-6
2			4			TOTAL SHEETS 7

LEGEND	
	CONCRETE REPAIR AREA (CR)
	SHOTCRETE REPAIR AREA (SCR)
	EPOXY RESIN INJECTION (ERI)

	AS-BUILT REPAIR QUANTITY TABLE			
	ESTIMATE		ACTUAL	
SHOTCRETE REPAIRS	AREA SQ. FT.	VOLUME CU. FT.	AREA SQ. FT.	VOLUME CU. FT.
	CAP/BACKWALL	3.2	1.2	
COLUMN/PILE	19.6	6.7		
CONCRETE REPAIRS	AREA SQ. FT.	VOLUME CU. FT.	AREA SQ. FT.	VOLUME CU. FT.
	CAP	5.6	2.0	
EPOXY RESIN INJECTION	LIN. FT.		LIN. FT.	
	CAP/BACKWALL	10.0		
COLUMN/PILE	15.0			

VALUES IN CHART REPRESENT ESTIMATED REPAIR TOTALS AFTER REMOVAL OF UNSOUND CONCRETE. MINIMUM OF 1" BEHIND REBAR AND MINIMUM 2" CLEARANCE TO SAWCUT. FOR REPAIR DETAILS, SEE "CONCRETE RESTORATION DETAILS" SHEETS.

**NOTES:**  
 REPAIR LOCATIONS AND ESTIMATED QUANTITIES ARE GIVEN WITH THE BEST INFORMATION AVAILABLE. IF ADDITIONAL REPAIRS NOT SHOWN ON THE DRAWINGS ARE DEEMED NECESSARY BY THE ENGINEER, THE ENGINEER WILL NOTE ON THE DRAWINGS THE APPROXIMATE LOCATIONS AND DESCRIPTION OF THE REPAIRS AND ADJUST THE ACTUAL QUANTITIES ENTERED INTO THE TABLE ABOVE.

CRACKING LOCATIONS AND QUANTITIES FOR LOCATIONS DESCRIBED AS "SCATTERED THROUGHOUT" IN THE INSPECTION REPORT ARE BASED ON THE BEST INFORMATION AVAILABLE. THE ENGINEER AND CONTRACTOR SHALL IDENTIFY AND REPAIR ALL CRACKS  $\geq 1/16"$  AS DESCRIBED IN THE SPECIAL PROVISIONS AT EACH BENT.

AVERAGE CONCRETE COVER IS EXPECTED TO BE FROM 2" TO 3" ON THE CAP AND FROM 1 1/2" TO 2" ON THE PILES. ACTUAL CONCRETE COVER SHALL BE DETERMINED BY THE CONTRACTOR AND PRESENTED TO THE ENGINEER PRIOR TO BEGINNING EXCAVATION/ DEMOLITION.

FOR CONCRETE AND SHOTCRETE REPAIRS, SEE "CONCRETE RESTORATION DETAILS" SHEETS.

SHOTCRETE REPAIRS MAY BE REPLACED WITH CONCRETE REPAIRS WITH THE APPROVAL OF THE ENGINEER.

REPAIRS TO THE BENT CAP MAY REQUIRE BRIDGE JACKING. FOR BRIDGE JACKING, SEE SPECIAL PROVISIONS.

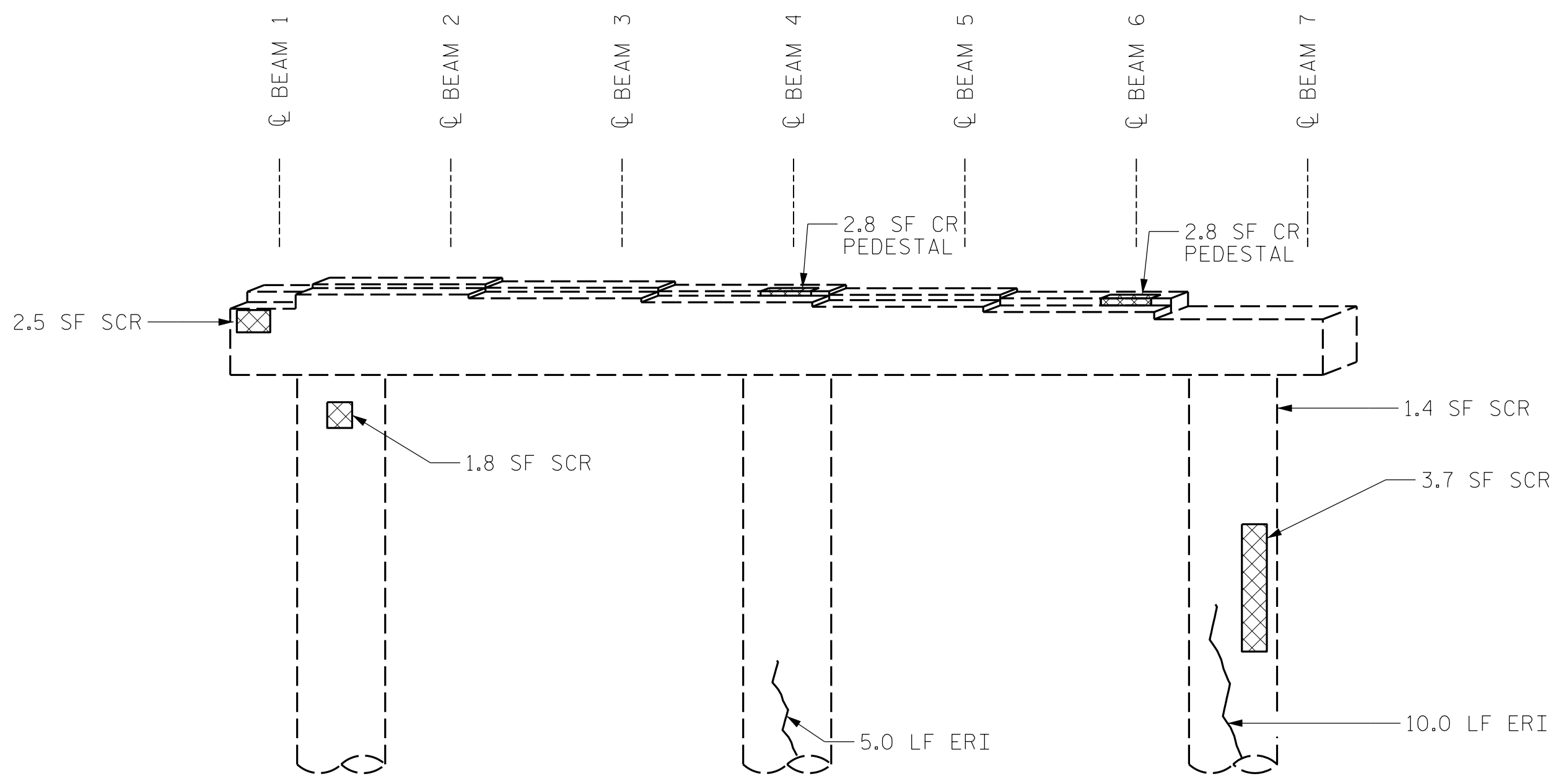

BENT 2  
(WEST FACE)

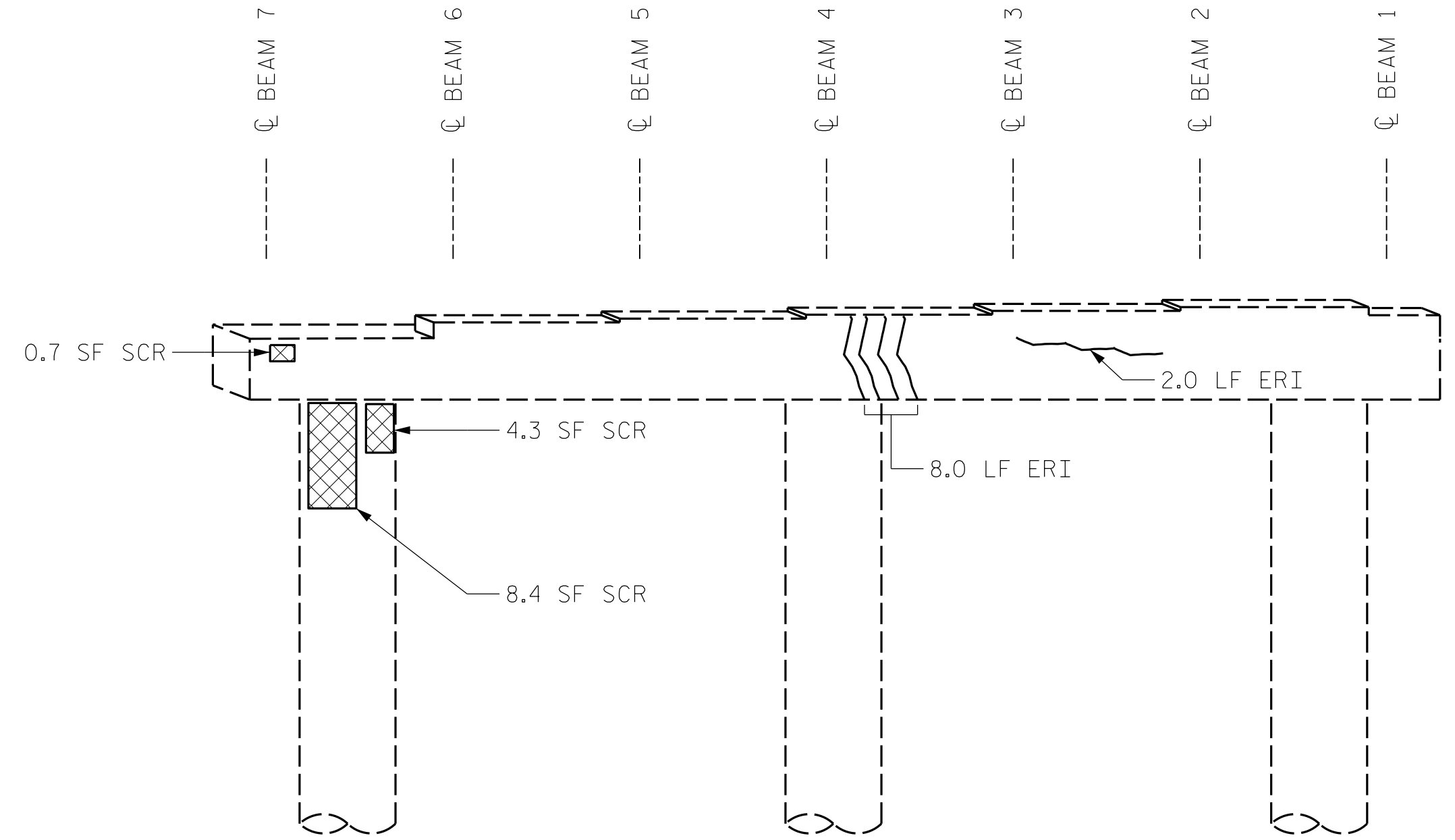

BENT 2  
(EAST FACE)

PROJECT NO. I-5915B  
CATAWBA COUNTY  
 BRIDGE NO. 170171

SHEET 3 OF 3

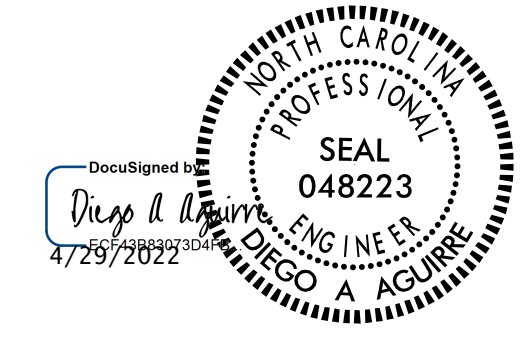

STATE OF NORTH CAROLINA  
 DEPARTMENT OF TRANSPORTATION  
 RALEIGH  
**SUBSTRUCTURE REPAIRS**  
 BENT 2



DRAWN BY : ALLEN J. MCSWAIN DATE : 01/2022  
 CHECKED BY : FIDEL L. FLORES DATE : 01/2022  
 DESIGN ENGINEER OF RECORD: DIEGO A. AGUIRRE DATE : 01/2022

DOCUMENT NOT CONSIDERED FINAL UNLESS ALL SIGNATURES COMPLETED

REVISIONS						SHEET NO.
NO.	BY:	DATE:	NO.	BY:	DATE:	
1			3			S1-7
2			4			TOTAL SHEETS 7

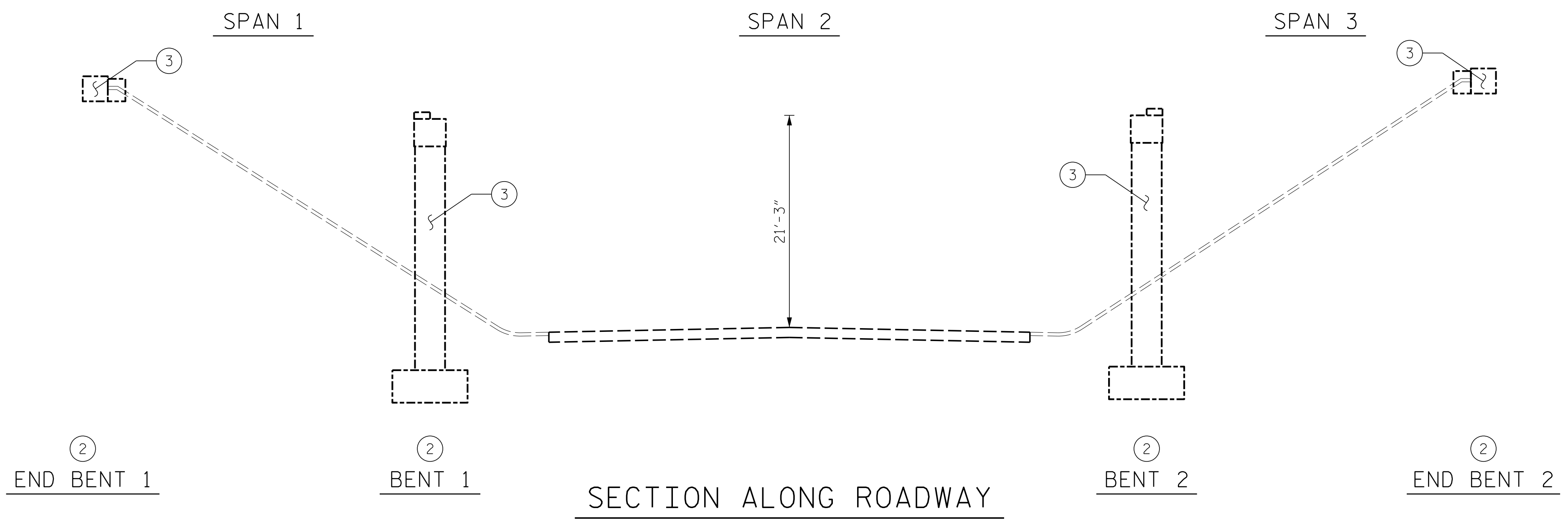

- SCOPE LEGEND:**
- ① CLEAR SHOULDERS OF DEBRIS AND VEGETATION
  - ② SUBSTRUCTURE CONCRETE REPAIRS
  - ③ SUBSTRUCTURE EPOXY RESIN INJECTION
  - ④ APPROACH ROADWAY MILLING AND RESURFACING

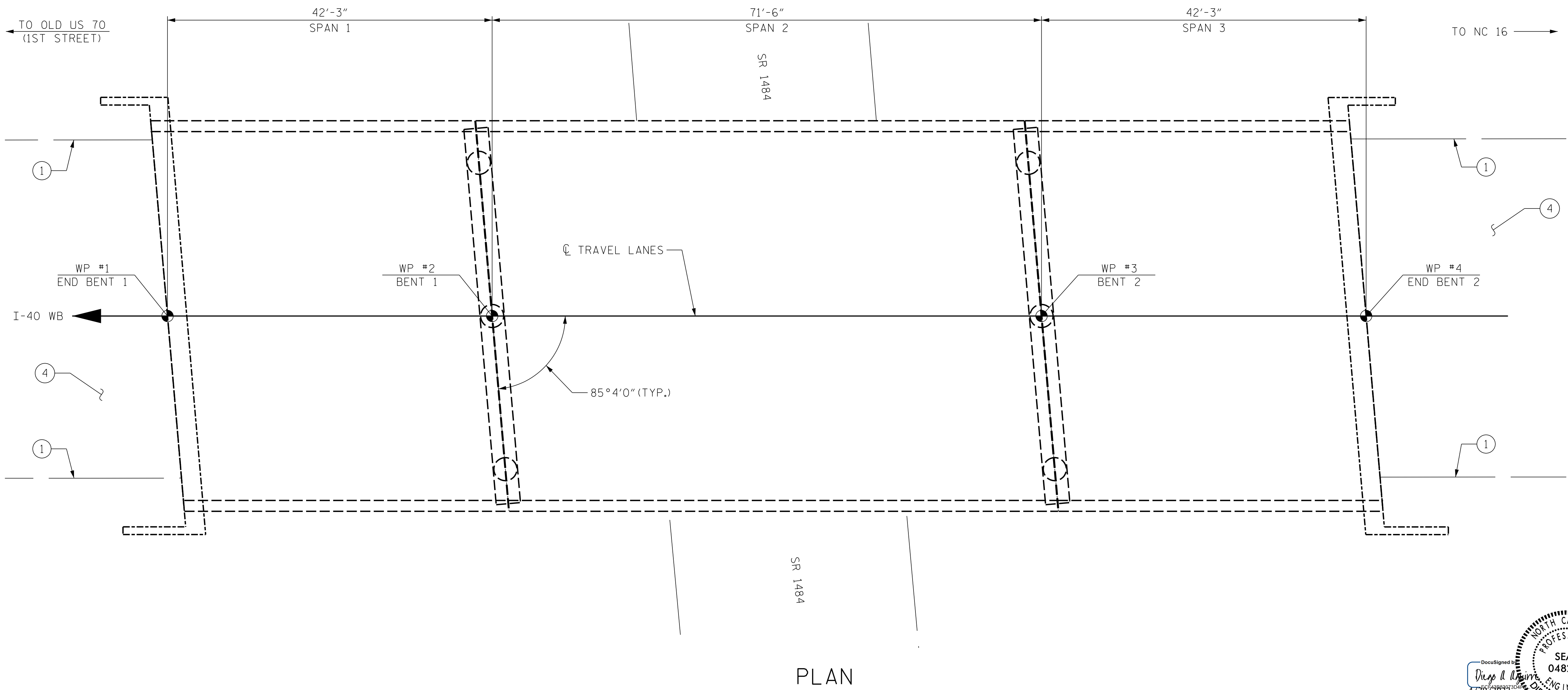

I HEREBY CERTIFY THAT THIS STRUCTURE WAS REHABILITATED ACCORDING TO THESE PLANS OR AS NOTED THEREIN.

RESIDENT ENGINEER \_\_\_\_\_ DATE \_\_\_\_\_

PROJECT NO. I-5915B  
CATAWBA COUNTY  
 BRIDGE NO. 170172

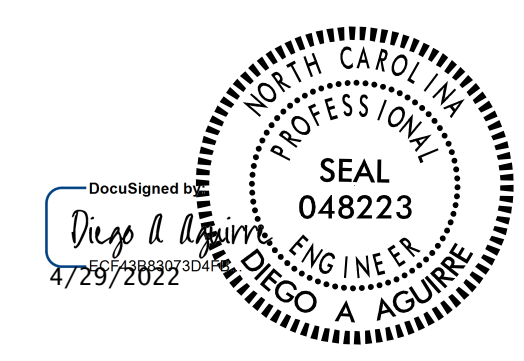

STATE OF NORTH CAROLINA  
 DEPARTMENT OF TRANSPORTATION  
 RALEIGH  
**GENERAL DRAWING**  
 FOR BRIDGE ON I-40 WB  
 OVER SR 1484

**NOTES:**

GENERAL DRAWING INFORMATION IS TAKEN FROM THE ORIGINAL PLANS AND THE MOST UP TO DATE ROUTINE INSPECTION REPORT DATED 04/15/2021

DRAWN BY : DIEGO A. AGUIRRE DATE : 01/2022  
 CHECKED BY : FIDEL L. FLORES DATE : 01/2022  
 DESIGN ENGINEER OF RECORD: DIEGO A. AGUIRRE DATE : 01/2022

DOCUMENT NOT CONSIDERED FINAL UNLESS ALL SIGNATURES COMPLETED

**KCA**  
 KISINGER CAMPO & ASSOCIATES  
 301 FAYETTEVILLE ST., SUITE 1500  
 RALEIGH, NC 27601 (919) 882-7839  
 NC FIRM LICENSE: C-1506

REVISIONS						SHEET NO.
NO.	BY:	DATE:	NO.	BY:	DATE:	
1			3			S2-1
2			4			TOTAL SHEETS 6



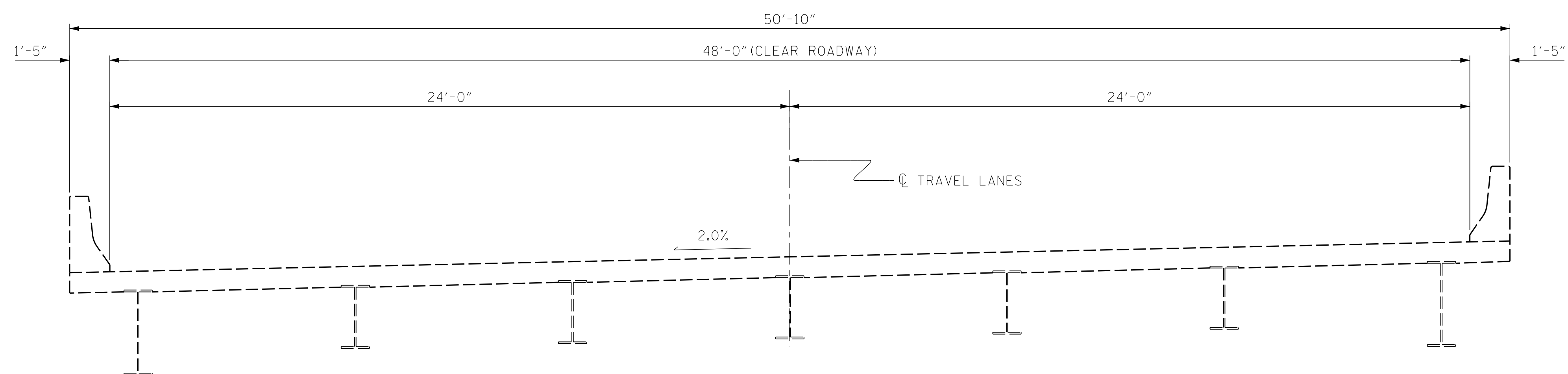

EXISTING

PROJECT NO. I-5915B  
CATAWBA COUNTY  
 BRIDGE NO. 170172

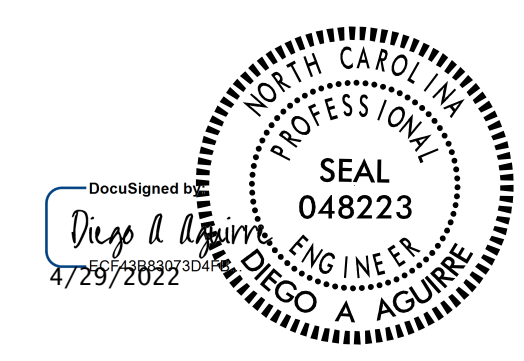

**KCA**  
**KISINGER CAMPO**  
**& ASSOCIATES**  
 301 FAYETTEVILLE ST., SUITE 1500  
 RALEIGH, NC 27601 (919) 882-7839  
 NC FIRM LICENSE: C-1506

STATE OF NORTH CAROLINA DEPARTMENT OF TRANSPORTATION RALEIGH						SHEET NO.
TYPICAL SECTION						S2-2
REVISIONS						TOTAL SHEETS
NO.	BY:	DATE:	NO.	BY:	DATE:	6
1			3			
2			4			

DRAWN BY : DIEGO A. AGUIRRE DATE : 01/2022  
 CHECKED BY : FIDEL L. FLORES DATE : 01/2022  
 DESIGN ENGINEER OF RECORD: DIEGO A. AGUIRRE DATE : 01/2022

DOCUMENT NOT CONSIDERED  
 FINAL UNLESS ALL  
 SIGNATURES COMPLETED

# AS-BUILT REPAIR QUANTITY TABLE

	ESTIMATE	ACTUAL
INCIDENTAL MILLING	490 SY	
ASPHALT CONCRETE SURFACE COURSE, TYPE S9.5C	41 TON	
ASPHALT BINDER FOR PLANT MIX	2.5 TON	

## NOTES:

INCIDENTAL MILLING - EXISTING APPROACH ASPHALT PAVEMENT TO BE MILLED AS NECESSARY TO ATTAIN MINIMUM 1/2" DEPTH OF NEW ASPHALT PAVEMENT. NEW ASPHALT PAVEMENT SHALL BE OF THICKNESS NECESSARY TO PROVIDE A SMOOTH TRANSITION BETWEEN THE ROADWAY AND THE BRIDGE DECK. THE NEW ASPHALT PAVEMENT THICKNESS MAY EXCEED 1/2" DUE TO SETTLEMENT OF THE EXISTING APPROACH.

FOR NEW ASPHALT PLACEMENT, SEE STANDARD SPECIFICATIONS.

GRADE MAY BE ADJUSTED BY THE ENGINEER TO ENSURE PROPER TIE-IN AT THE END BENTS.

C1	PROPOSED VARIABLE DEPTH ASPHALT CONCRETE SURFACE COURSE, TYPE S9.5C AT AN AVERAGE RATE OF 112 LBS. PER SQ. YD. PER 1" DEPTH. TO BE PLACED IN LAYERS NOT LESS THAN 1" OR GREATER THAN 2" IN DEPTH.
----	---

INCIDENTAL MILLING

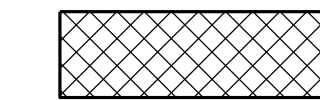

ASPHALT CONCRETE SURFACE COURSE, TYPE S9.5C (C1)

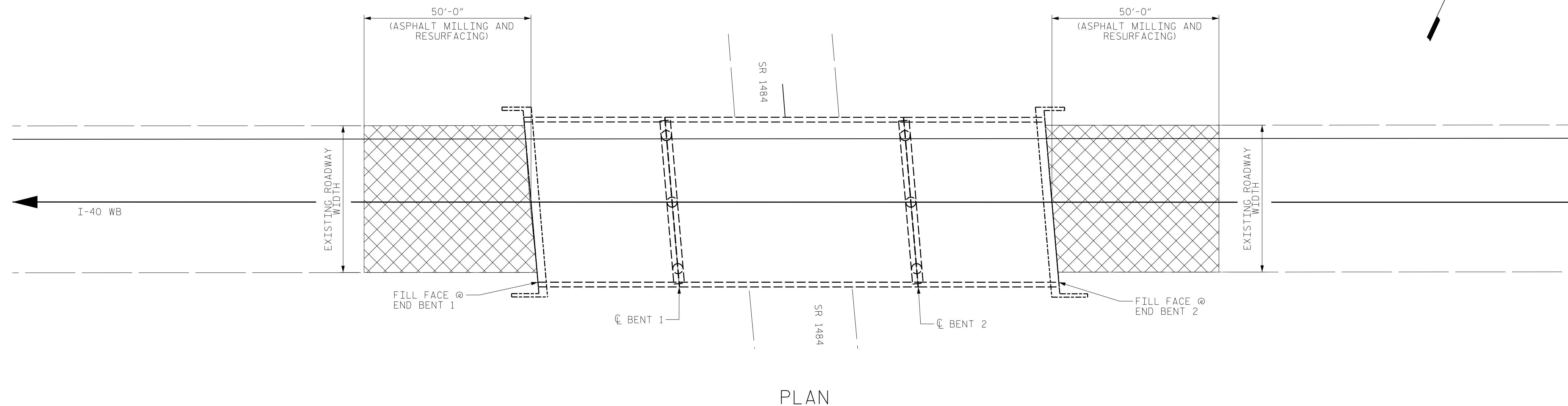

PLAN

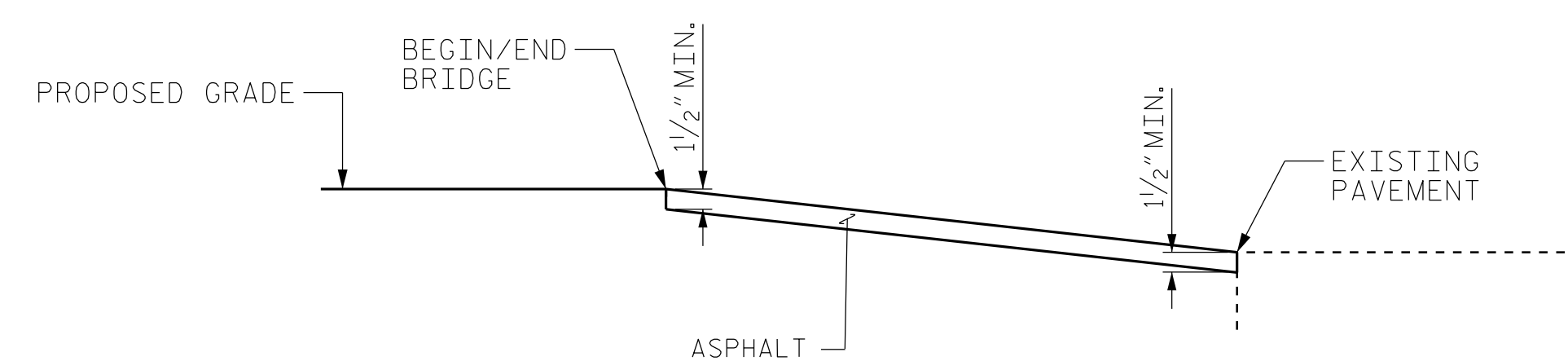

PAVEMENT KEY-IN DETAIL FOR BOTH END BENTS

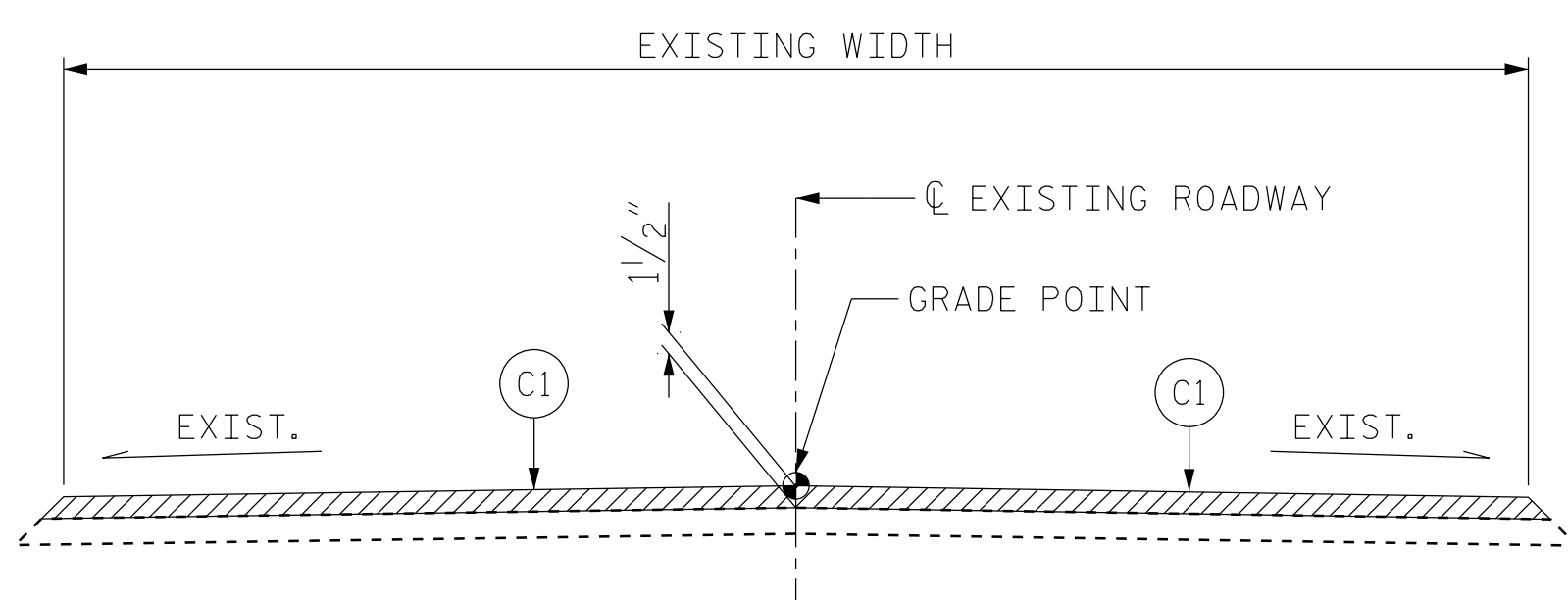

ROADWAY SECTION  
BEGIN/END BRIDGE

PROJECT NO. I-5915B  
CATAWBA COUNTY  
 BRIDGE NO. 170172

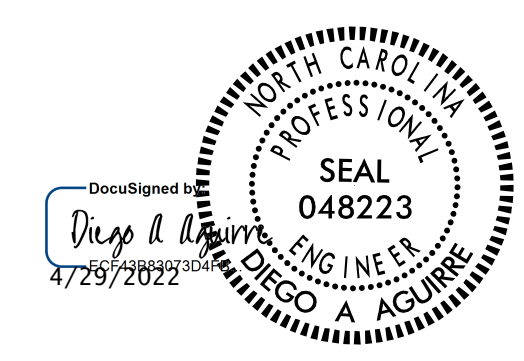

STATE OF NORTH CAROLINA  
 DEPARTMENT OF TRANSPORTATION  
 RALEIGH  
**APPROACH ROADWAY  
 MILLING AND RESURFACING**



DRAWN BY : FIDEL L. FLORES DATE : 01/2022  
 CHECKED BY : JACOB H. DUKE DATE : 01/2022  
 DESIGN ENGINEER OF RECORD: DIEGO A. AGUIRRE DATE : 01/2022

4/21/2022  
 I5915B.SMU.AR01.170172.dgn  
 daguirre

DOCUMENT NOT CONSIDERED  
 FINAL UNLESS ALL  
 SIGNATURES COMPLETED

REVISIONS						SHEET NO.
NO.	BY:	DATE:	NO.	BY:	DATE:	TOTAL SHEETS
1			3			6
2			4			

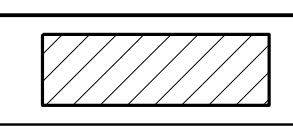
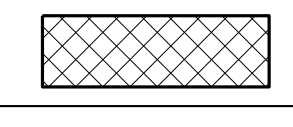
SHEET NO.  
**S2-3**

LEGEND	
	CONCRETE REPAIR AREA (CR)
	SHOTCRETE REPAIR AREA (SCR)
	EPOXY RESIN INJECTION (ERI)

	AS-BUILT REPAIR QUANTITY TABLE			
	ESTIMATE		ACTUAL	
SHOTCRETE REPAIRS	AREA SQ. FT.	VOLUME CU. FT.	AREA SQ. FT.	VOLUME CU. FT.
CAP/BACKWALL	-	-		
COLUMN/PILE	-	-		
CONCRETE REPAIRS	AREA SQ. FT.	VOLUME CU. FT.	AREA SQ. FT.	VOLUME CU. FT.
CAP	-	-		
EPOXY RESIN INJECTION	LIN. FT.		LIN. FT.	
CAP/BACKWALL	89.0			
COLUMN/PILE	-			

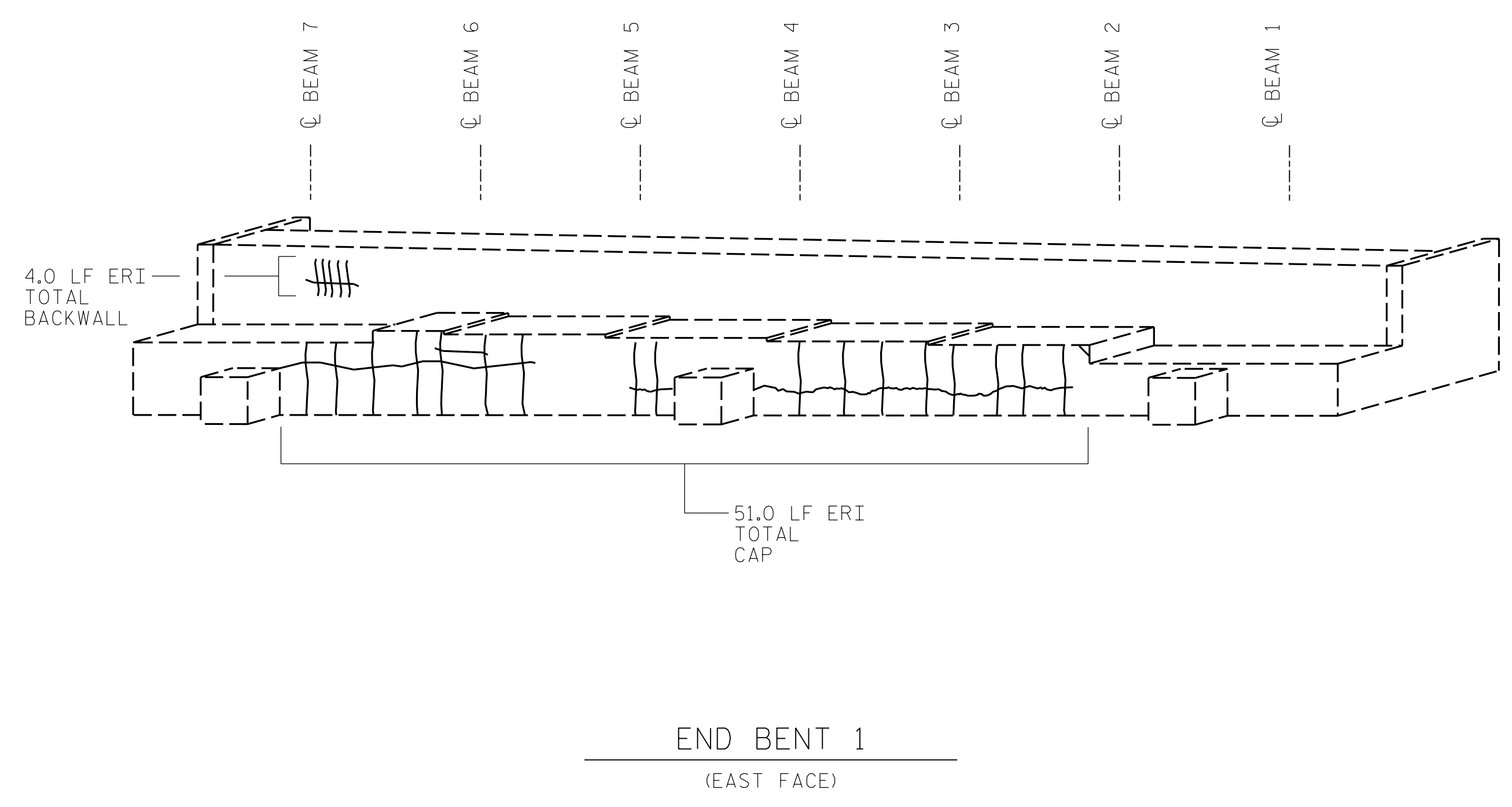

END BENT 1  
(EAST FACE)

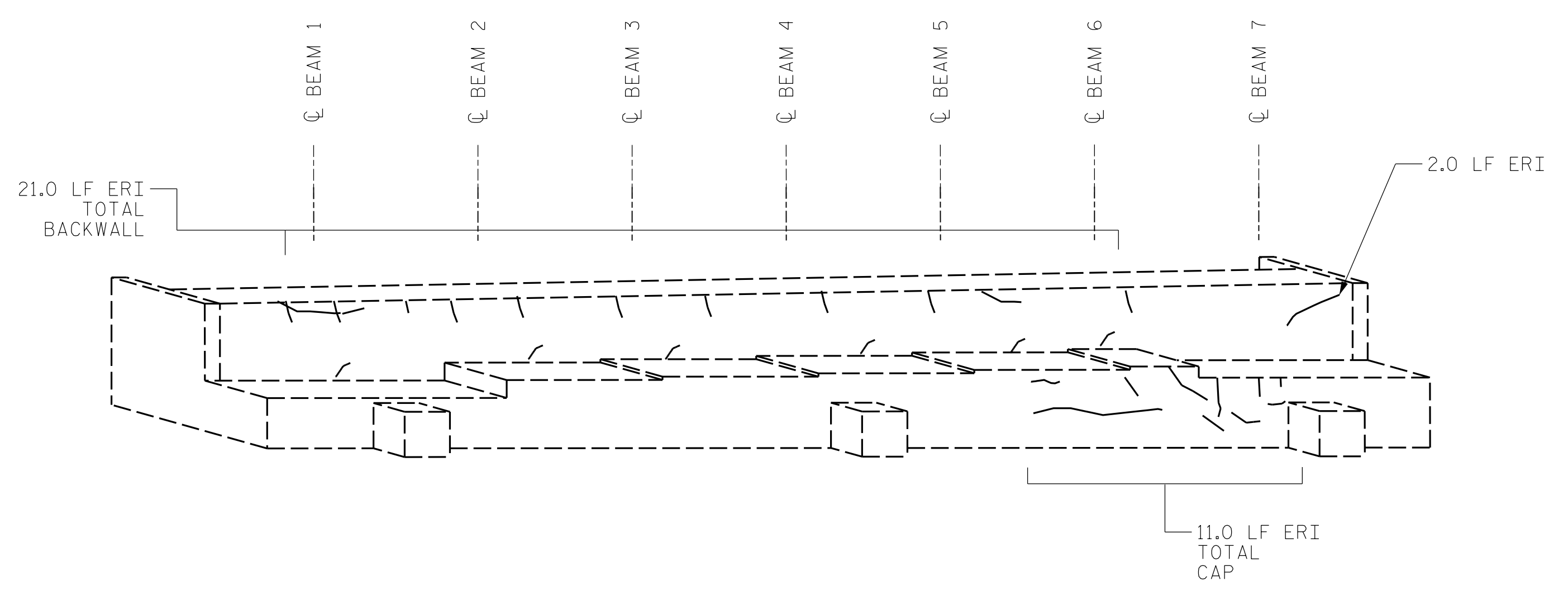

END BENT 2  
(WEST FACE)

VALUES IN CHART REPRESENT ESTIMATED REPAIR TOTALS AFTER REMOVAL OF UNSOUND CONCRETE. MINIMUM OF 1" BEHIND REBAR AND MINIMUM 2" CLEARANCE TO SAWCUT. FOR REPAIR DETAILS, SEE "CONCRETE RESTORATION DETAILS" SHEETS.

**NOTES:**  
REPAIR LOCATIONS AND ESTIMATED QUANTITIES ARE GIVEN WITH THE BEST INFORMATION AVAILABLE. IF ADDITIONAL REPAIRS NOT SHOWN ON THE DRAWINGS ARE DEEMED NECESSARY BY THE ENGINEER, THE ENGINEER WILL NOTE ON THE DRAWINGS THE APPROXIMATE LOCATIONS AND DESCRIPTION OF THE REPAIRS AND ADJUST THE ACTUAL QUANTITIES ENTERED INTO THE TABLE ABOVE.

CRACKING LOCATIONS AND QUANTITIES FOR LOCATIONS DESCRIBED AS "SCATTERED THROUGHOUT" IN THE INSPECTION REPORT ARE BASED ON THE BEST INFORMATION AVAILABLE. THE ENGINEER AND CONTRACTOR SHALL IDENTIFY AND REPAIR ALL CRACKS  $\geq 1/16"$  AS DESCRIBED IN THE SPECIAL PROVISIONS AT EACH BENT.

AVERAGE CONCRETE COVER IS EXPECTED TO BE FROM 2" TO 3" ON THE CAP AND FROM 1 1/2" TO 2" ON THE PILES. ACTUAL CONCRETE COVER SHALL BE DETERMINED BY THE CONTRACTOR AND PRESENTED TO THE ENGINEER PRIOR TO BEGINNING EXCAVATION/ DEMOLITION.

FOR CONCRETE AND SHOTCRETE REPAIRS, SEE "CONCRETE RESTORATION DETAILS" SHEETS.

SHOTCRETE REPAIRS MAY BE REPLACED WITH CONCRETE REPAIRS WITH THE APPROVAL OF THE ENGINEER.

REPAIRS TO THE BENT CAP MAY REQUIRE BRIDGE JACKING. FOR BRIDGE JACKING, SEE SPECIAL PROVISIONS.

PROJECT NO. I-5915B  
CATAWBA COUNTY  
BRIDGE NO. 170172

SHEET 1 OF 3

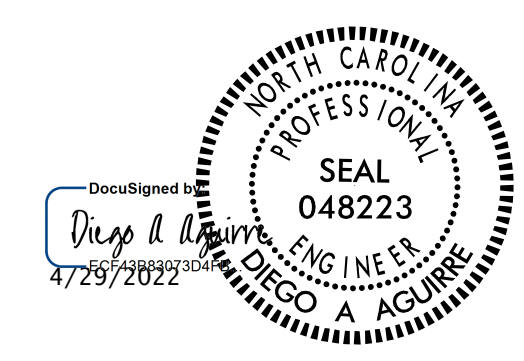

STATE OF NORTH CAROLINA  
DEPARTMENT OF TRANSPORTATION  
RALEIGH  
**SUBSTRUCTURE REPAIRS**  
END BENTS 1 & 2



DRAWN BY : ALLEN J. MCSWAIN DATE : 01/2022  
CHECKED BY : FIDEL L. FLORES DATE : 01/2022  
DESIGN ENGINEER OF RECORD: DIEGO A. AGUIRRE DATE : 01/2022

DOCUMENT NOT CONSIDERED FINAL UNLESS ALL SIGNATURES COMPLETED

REVISIONS						SHEET NO.
NO.	BY:	DATE:	NO.	BY:	DATE:	
1			3			S2-4
2			4			TOTAL SHEETS 6



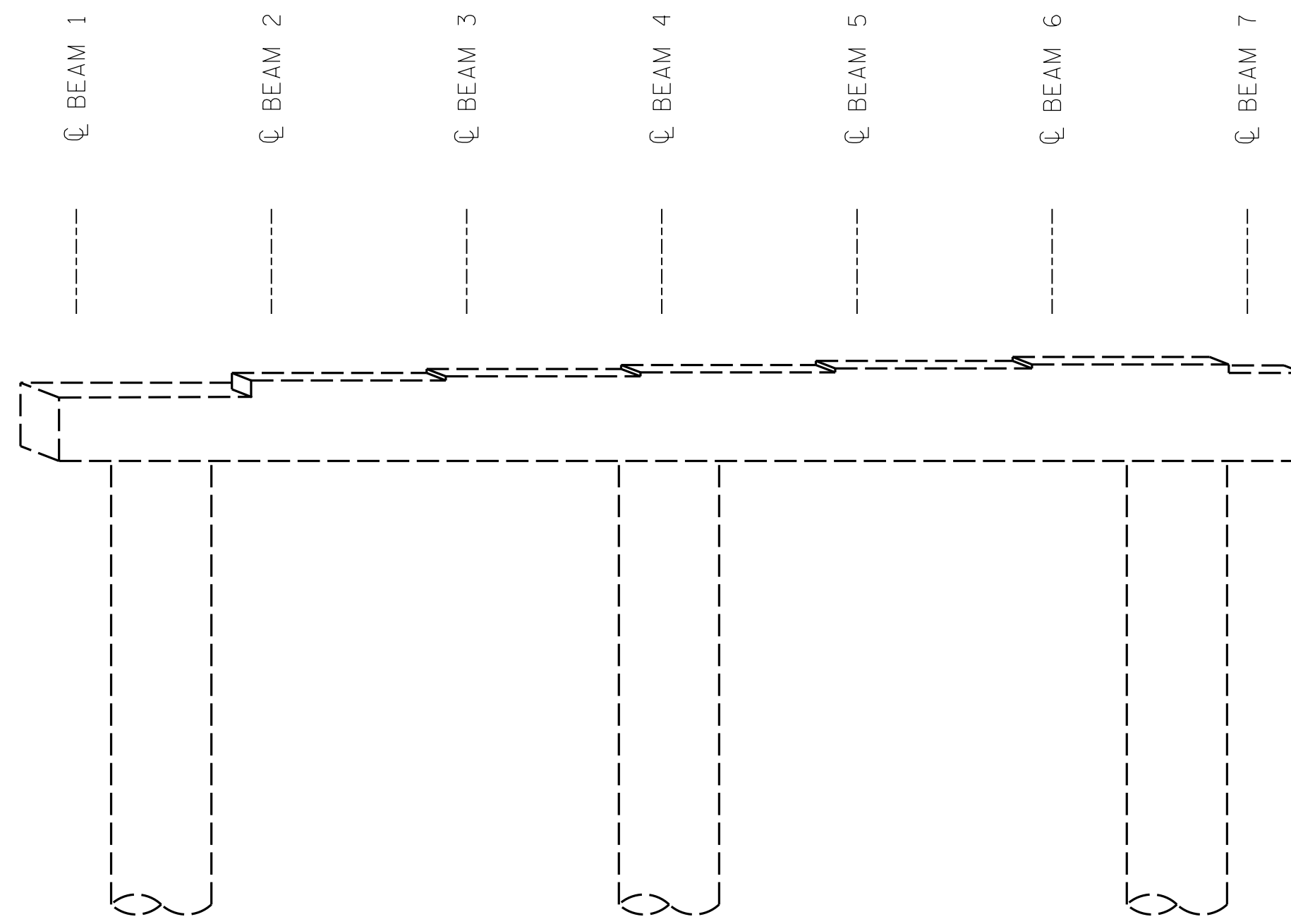

BENT 1  
(WEST FACE)

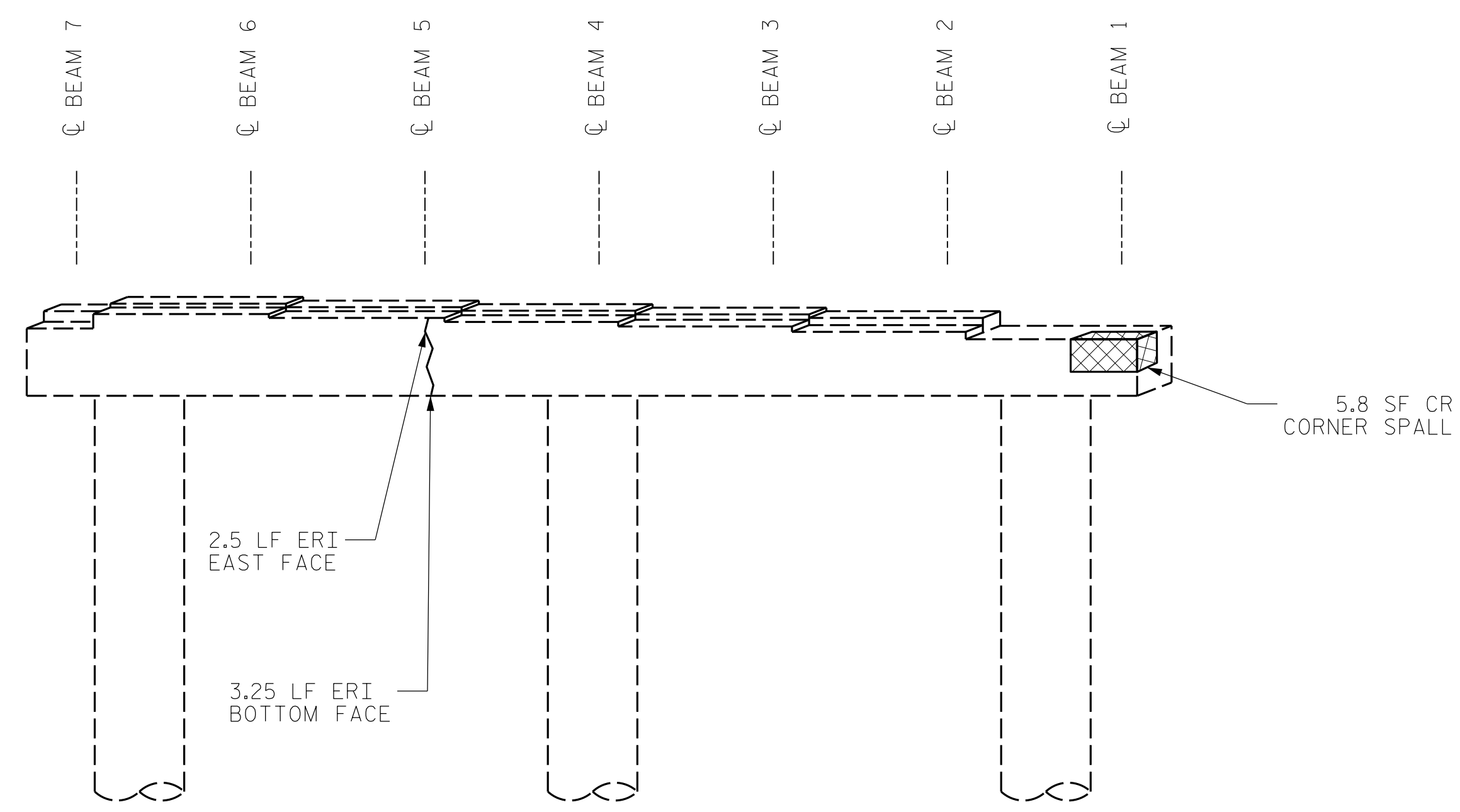

BENT 1  
(EAST FACE)

LEGEND	
	CONCRETE REPAIR AREA (CR)
	SHOTCRETE REPAIR AREA (SCR)
	EPOXY RESIN INJECTION (ERI)

		AS-BUILT REPAIR QUANTITY TABLE			
		ESTIMATE		ACTUAL	
SHOTCRETE REPAIRS		AREA SQ. FT.	VOLUME CU. FT.	AREA SQ. FT.	VOLUME CU. FT.
CAP/BACKWALL		-	-		
COLUMN/PILE		-	-		
CONCRETE REPAIRS		AREA SQ. FT.	VOLUME CU. FT.	AREA SQ. FT.	VOLUME CU. FT.
CAP		5.8	2.9		
EPOXY RESIN INJECTION		LIN. FT.		LIN. FT.	
CAP/BACKWALL		5.7			
COLUMN/PILE		-			

VALUES IN CHART REPRESENT ESTIMATED REPAIR TOTALS AFTER REMOVAL OF UNSOUND CONCRETE. MINIMUM OF 1" BEHIND REBAR AND MINIMUM 2" CLEARANCE TO SAWCUT. FOR REPAIR DETAILS, SEE "CONCRETE RESTORATION DETAILS" SHEETS.

**NOTES:**  
REPAIR LOCATIONS AND ESTIMATED QUANTITIES ARE GIVEN WITH THE BEST INFORMATION AVAILABLE. IF ADDITIONAL REPAIRS NOT SHOWN ON THE DRAWINGS ARE DEEMED NECESSARY BY THE ENGINEER, THE ENGINEER WILL NOTE ON THE DRAWINGS THE APPROXIMATE LOCATIONS AND DESCRIPTION OF THE REPAIRS AND ADJUST THE ACTUAL QUANTITIES ENTERED INTO THE TABLE ABOVE.

CRACKING LOCATIONS AND QUANTITIES FOR LOCATIONS DESCRIBED AS "SCATTERED THROUGHOUT" IN THE INSPECTION REPORT ARE BASED ON THE BEST INFORMATION AVAILABLE. THE ENGINEER AND CONTRACTOR SHALL IDENTIFY AND REPAIR ALL CRACKS  $\geq 1/16"$  AS DESCRIBED IN THE SPECIAL PROVISIONS AT EACH BENT.

AVERAGE CONCRETE COVER IS EXPECTED TO BE FROM 2" TO 3" ON THE CAP AND FROM 1 1/2" TO 2" ON THE PILES. ACTUAL CONCRETE COVER SHALL BE DETERMINED BY THE CONTRACTOR AND PRESENTED TO THE ENGINEER PRIOR TO BEGINNING EXCAVATION/ DEMOLITION.

FOR CONCRETE AND SHOTCRETE REPAIRS, SEE "CONCRETE RESTORATION DETAILS" SHEETS.

SHOTCRETE REPAIRS MAY BE REPLACED WITH CONCRETE REPAIRS WITH THE APPROVAL OF THE ENGINEER.

REPAIRS TO THE BENT CAP MAY REQUIRE BRIDGE JACKING. FOR BRIDGE JACKING, SEE SPECIAL PROVISIONS.

PROJECT NO. I-5915B  
CATAWBA COUNTY  
 BRIDGE NO. 170172

SHEET 2 OF 3

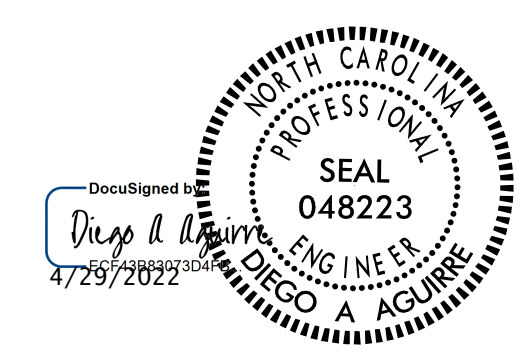

STATE OF NORTH CAROLINA  
 DEPARTMENT OF TRANSPORTATION  
 RALEIGH  
**SUBSTRUCTURE REPAIRS**  
 BENT 1



DRAWN BY : ALLEN J. MCSWAIN DATE : 01/2022  
 CHECKED BY : FIDEL L. FLORES DATE : 01/2022  
 DESIGN ENGINEER OF RECORD: DIEGO A. AGUIRRE DATE : 01/2022

DOCUMENT NOT CONSIDERED FINAL UNLESS ALL SIGNATURES COMPLETED

REVISIONS						SHEET NO.
NO.	BY:	DATE:	NO.	BY:	DATE:	
1			3			S2-5
2			4			TOTAL SHEETS 6

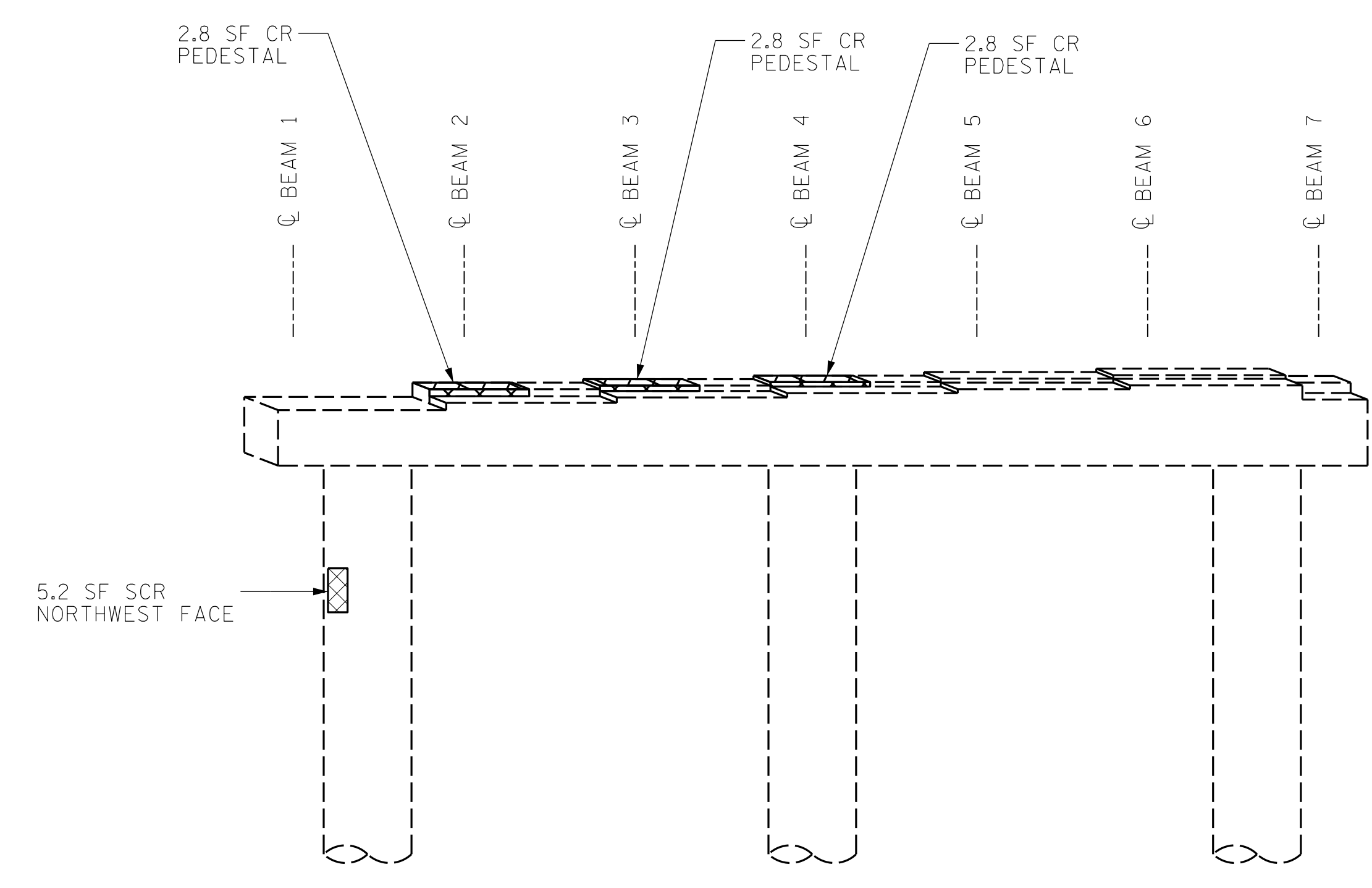

BENT 2  
(WEST FACE)

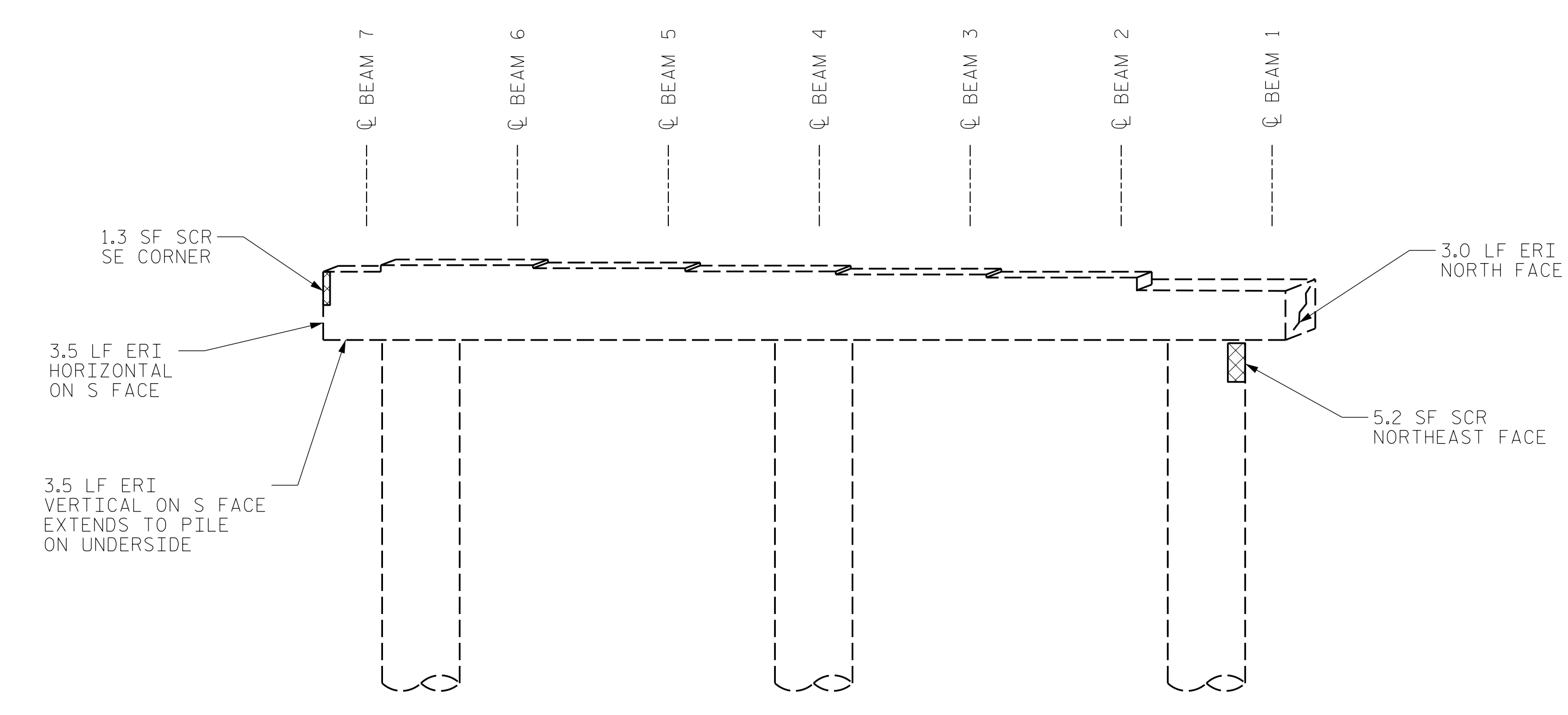

BENT 2  
(EAST FACE)

LEGEND	
	CONCRETE REPAIR AREA (CR)
	SHOTCRETE REPAIR AREA (SCR)
	EPOXY RESIN INJECTION (ERI)

	AS-BUILT REPAIR QUANTITY TABLE			
	ESTIMATE		ACTUAL	
SHOTCRETE REPAIRS	AREA SQ. FT.	VOLUME CU. FT.	AREA SQ. FT.	VOLUME CU. FT.
CAP/BACKWALL	1.3	0.5		
COLUMN/PILE	10.4	3.6		
CONCRETE REPAIRS	AREA SQ. FT.	VOLUME CU. FT.	AREA SQ. FT.	VOLUME CU. FT.
CAP	8.4	3.0		
EPOXY RESIN INJECTION	LIN. FT.		LIN. FT.	
CAP/BACKWALL	10.0			
COLUMN/PILE	-			

VALUES IN CHART REPRESENT ESTIMATED REPAIR TOTALS AFTER REMOVAL OF UNSOUND CONCRETE. MINIMUM OF 1" BEHIND REBAR AND MINIMUM 2" CLEARANCE TO SAWCUT. FOR REPAIR DETAILS, SEE "CONCRETE RESTORATION DETAILS" SHEETS.

**NOTES:**  
REPAIR LOCATIONS AND ESTIMATED QUANTITIES ARE GIVEN WITH THE BEST INFORMATION AVAILABLE. IF ADDITIONAL REPAIRS NOT SHOWN ON THE DRAWINGS ARE DEEMED NECESSARY BY THE ENGINEER, THE ENGINEER WILL NOTE ON THE DRAWINGS THE APPROXIMATE LOCATIONS AND DESCRIPTION OF THE REPAIRS AND ADJUST THE ACTUAL QUANTITIES ENTERED INTO THE TABLE ABOVE.

CRACKING LOCATIONS AND QUANTITIES FOR LOCATIONS DESCRIBED AS "SCATTERED THROUGHOUT" IN THE INSPECTION REPORT ARE BASED ON THE BEST INFORMATION AVAILABLE. THE ENGINEER AND CONTRACTOR SHALL IDENTIFY AND REPAIR ALL CRACKS  $\geq 1/16"$  AS DESCRIBED IN THE SPECIAL PROVISIONS AT EACH BENT.

AVERAGE CONCRETE COVER IS EXPECTED TO BE FROM 2" TO 3" ON THE CAP AND FROM 1 1/2" TO 2" ON THE PILES. ACTUAL CONCRETE COVER SHALL BE DETERMINED BY THE CONTRACTOR AND PRESENTED TO THE ENGINEER PRIOR TO BEGINNING EXCAVATION/ DEMOLITION.

FOR CONCRETE AND SHOTCRETE REPAIRS, SEE "CONCRETE RESTORATION DETAILS" SHEETS.

SHOTCRETE REPAIRS MAY BE REPLACED WITH CONCRETE REPAIRS WITH THE APPROVAL OF THE ENGINEER.

REPAIRS TO THE BENT CAP MAY REQUIRE BRIDGE JACKING. FOR BRIDGE JACKING, SEE SPECIAL PROVISIONS.

PROJECT NO. I-5915B  
CATAWBA COUNTY  
 BRIDGE NO. 170172

SHEET 3 OF 3

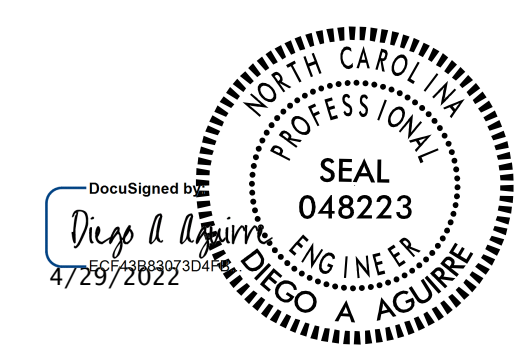

STATE OF NORTH CAROLINA  
 DEPARTMENT OF TRANSPORTATION  
 RALEIGH  
**SUBSTRUCTURE REPAIRS**  
 BENT 2

DRAWN BY : ALLEN J. MCSWAIN DATE : 01/2022  
 CHECKED BY : FIDEL L. FLORES DATE : 01/2022  
 DESIGN ENGINEER OF RECORD: DIEGO A. AGUIRRE DATE : 01/2022

DOCUMENT NOT CONSIDERED FINAL UNLESS ALL SIGNATURES COMPLETED

REVISIONS						SHEET NO.
NO.	BY:	DATE:	NO.	BY:	DATE:	
1			3			S2-6
2			4			TOTAL SHEETS 6

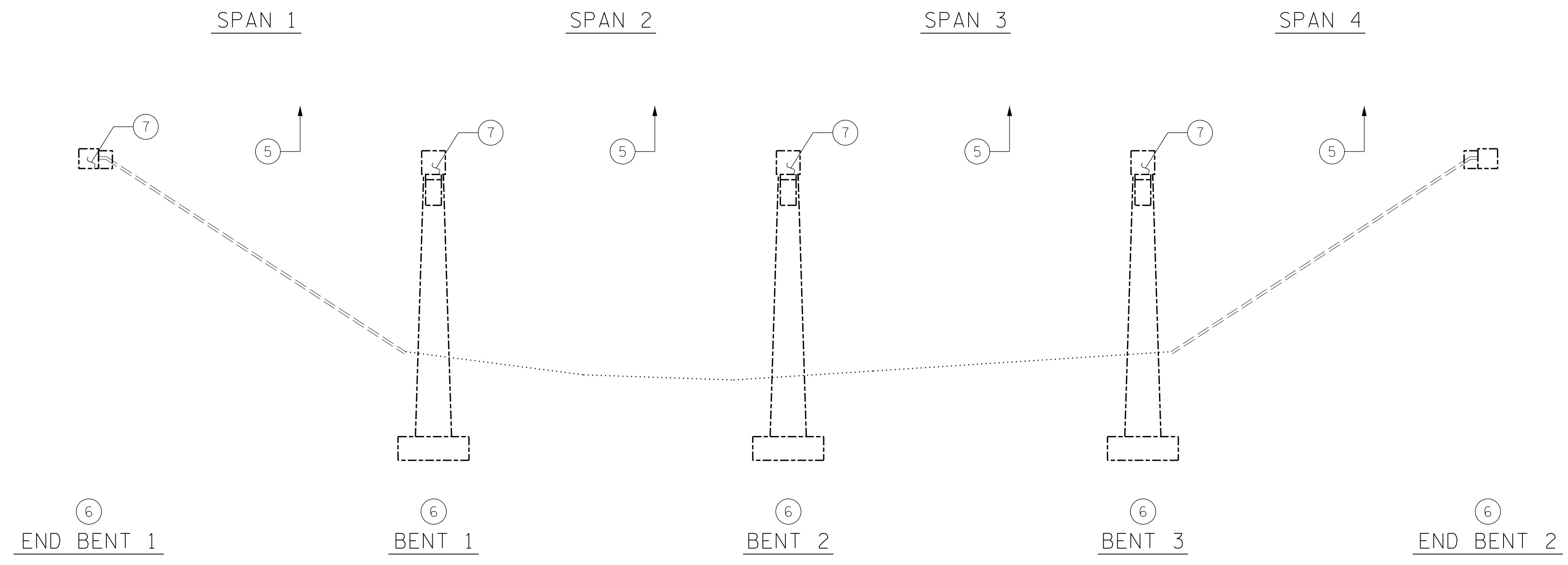

- SCOPE LEGEND:**
- ① CLEAR SHOULDERS OF DEBRIS AND VEGETATION
  - ② CONCRETE DECK REPAIRS AND SILANE DECK TREATMENT
  - ③ ASPHALT JOINT REPAIR/REPLACEMENT
  - ④ ADD ASPHALT WEARING SURFACE
  - ⑤ REINFORCED CONCRETE GIRDER REPAIRS
  - ⑥ SUBSTRUCTURE CONCRETE REPAIRS
  - ⑦ SUBSTRUCTURE EPOXY RESIN INJECTION
  - ⑧ APPROACH ROADWAY MILLING AND RESURFACING
  - ⑨ CLEAN AND PAINT EXISTING BEARINGS WITH HRCSA

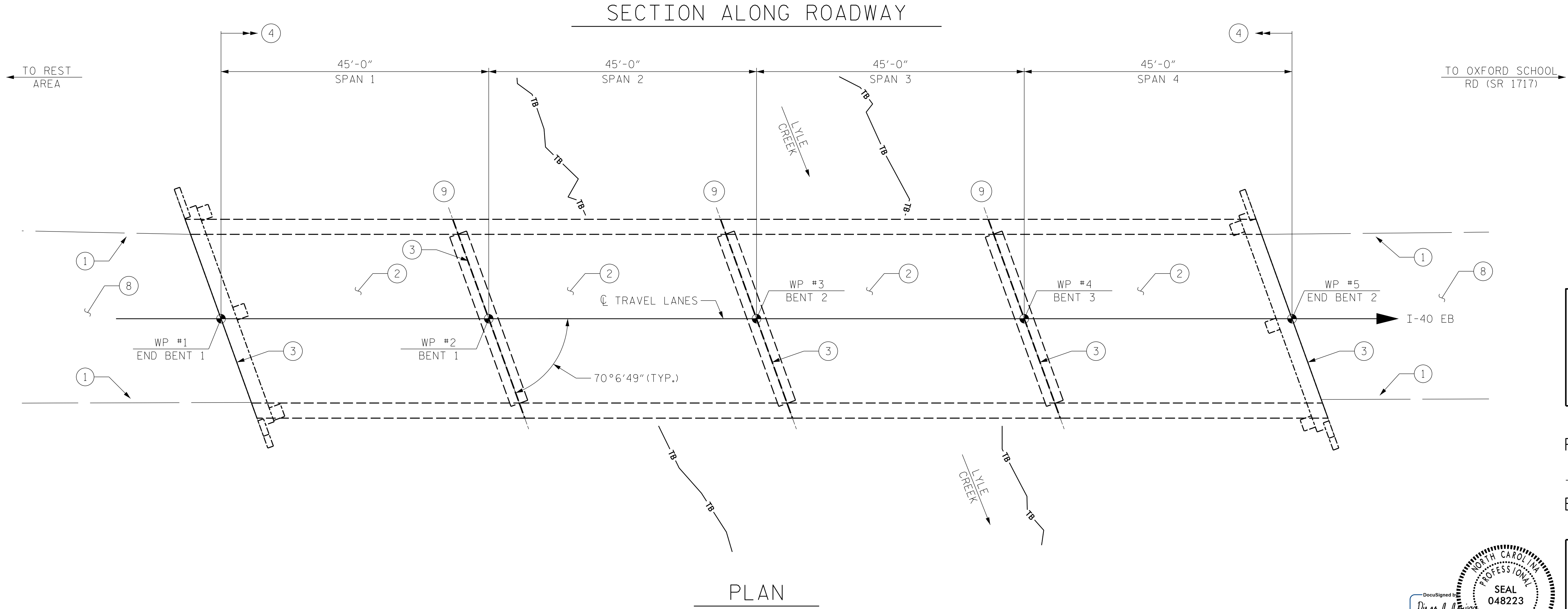

I HEREBY CERTIFY THAT THIS STRUCTURE WAS REHABILITATED ACCORDING TO THESE PLANS OR AS NOTED THEREIN.

RESIDENT ENGINEER \_\_\_\_\_ DATE \_\_\_\_\_

PROJECT NO. I-5915B  
CATAWBA COUNTY  
 BRIDGE NO. 170177

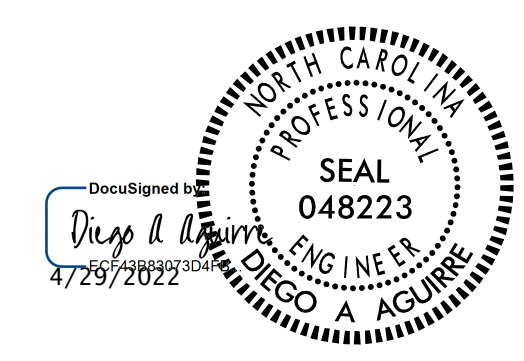

STATE OF NORTH CAROLINA  
 DEPARTMENT OF TRANSPORTATION  
 RALEIGH

**GENERAL DRAWING**

FOR BRIDGE ON I-40 EB  
 OVER LYLE CREEK

**NOTES:**

GENERAL DRAWING INFORMATION IS TAKEN FROM THE ORIGINAL PLANS AND THE MOST UP TO DATE ROUTINE INSPECTION REPORT DATED 03/20/2021.

DRAWN BY : DIEGO A. AGUIRRE DATE : 01/2022  
 CHECKED BY : FIDEL L. FLORES DATE : 01/2022  
 DESIGN ENGINEER OF RECORD: DIEGO A. AGUIRRE DATE : 01/2022

DOCUMENT NOT CONSIDERED FINAL UNLESS ALL SIGNATURES COMPLETED



REVISIONS						SHEET NO.	
NO.	BY:	DATE:	NO.	BY:	DATE:	TOTAL SHEETS	
1			3			3	11
2			4				



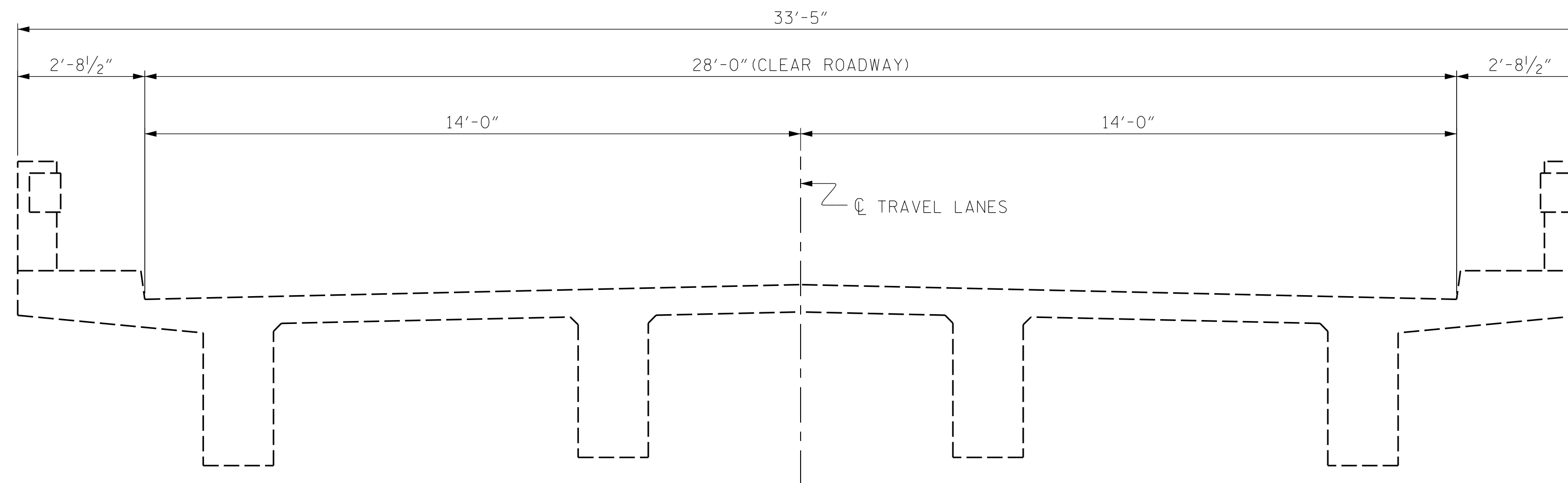

EXISTING

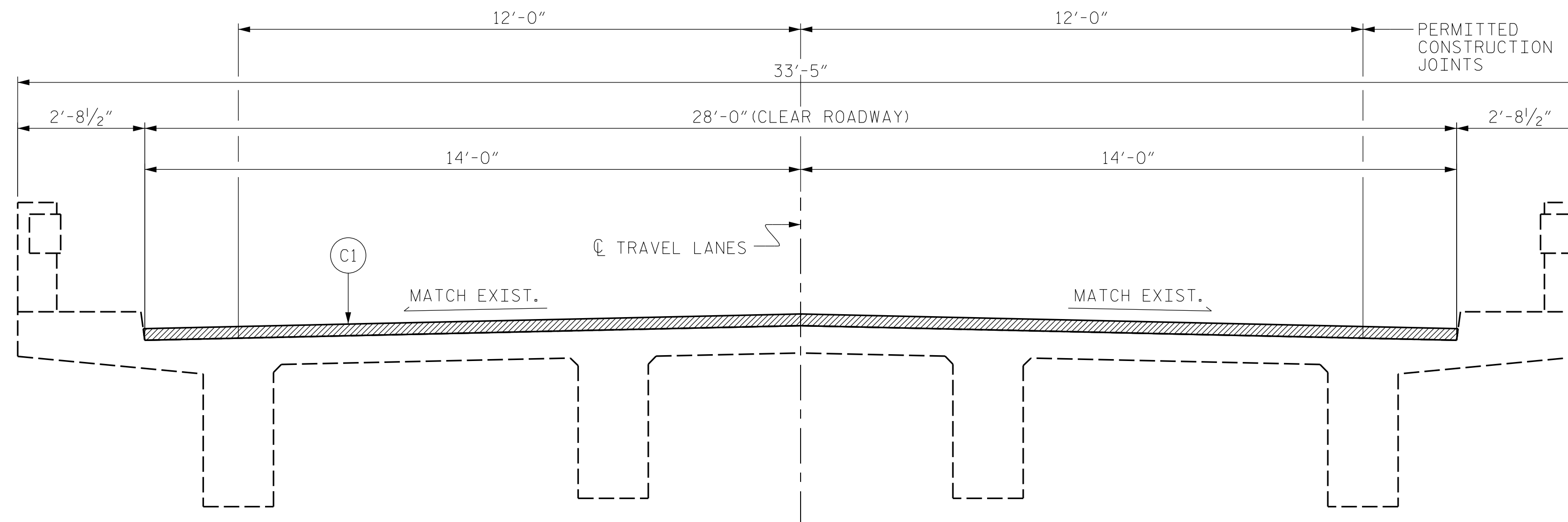

PROPOSED

**NOTES:**

LONGITUDINAL CONSTRUCTION JOINTS OF OVERLAYS SHALL BE LOCATED ALONG THE CENTERLINE OR EDGE OF TRAVEL LANES.

SEE TRAFFIC MANAGEMENT PLANS FOR LANE WIDTHS, SEQUENCING, AND OTHER TRAFFIC CONTROL MEASURES FOR STAGING OF ASPHALT WEARING SURFACE (AWS) OVERLAY.

FOR NEW ASPHALT PLACEMENT, SEE STANDARD SPECIFICATIONS.

C1	PROPOSED APPROXIMATE 2" MIN. ASPHALT CONCRETE SURFACE COURSE, TYPE S9.5C AT AN AVERAGE RATE OF 112 LBS. PER SQ. YD. PER 1" DEPTH. TO BE PLACED IN LAYERS NOT LESS THAN 1" OR GREATER THAN 2" IN DEPTH.
----	--

ASPHALT CONCRETE SURFACE COURSE, TYPE S9.5C

PROJECT NO. I-5915B  
CATAWBA COUNTY  
 BRIDGE NO. 170177



**KCS**  
**KISINGER CAMPO & ASSOCIATES**  
 301 FAYETTEVILLE ST., SUITE 1500  
 RALEIGH, NC 27601 (919) 882-7839  
 NC FIRM LICENSE: C-1506

STATE OF NORTH CAROLINA DEPARTMENT OF TRANSPORTATION RALEIGH						SHEET NO. <b>S3-2</b>
<b>TYPICAL SECTION</b>						TOTAL SHEETS 11
REVISIONS						
NO.	BY:	DATE:	NO.	BY:	DATE:	
1			3			
2			4			

DRAWN BY :	DIEGO A. AGUIRRE	DATE :	01/2022
CHECKED BY :	FIDEL L. FLORES	DATE :	01/2022
DESIGN ENGINEER OF RECORD:	DIEGO A. AGUIRRE	DATE :	01/2022

DOCUMENT NOT CONSIDERED  
 FINAL UNLESS ALL  
 SIGNATURES COMPLETED



# AS-BUILT REPAIR QUANTITY TABLE

## DECK REPAIRS

	SPAN 1		SPAN 2		SPAN 3		SPAN 4	
	ESTIMATE	ACTUAL	ESTIMATE	ACTUAL	ESTIMATE	ACTUAL	ESTIMATE	ACTUAL
CLASS II SURFACE PREPARATION	0.4 SY		6.8 SY		0.2 SY		31.8 SY	
CLASS III SURFACE PREPARATION	-- SY		-- SY		-- SY		-- SY	
	ESTIMATE	ACTUAL	ESTIMATE	ACTUAL	ESTIMATE	ACTUAL	ESTIMATE	ACTUAL
	AREA	VOLUME	AREA	VOLUME	AREA	VOLUME	AREA	VOLUME
SHOTCRETE REPAIR AREA (SCR)	-- SF	-- CF			8.1 SF	2.7 CF	-- SF	-- CF
	ESTIMATE	ACTUAL	ESTIMATE	ACTUAL	ESTIMATE	ACTUAL	ESTIMATE	ACTUAL
SHOTBLASTING BRIDGE DECK	140 SY		140 SY		140 SY		140 SY	
SILANE DECK TREATMENT	140 SY		140 SY		140 SY		140 SY	

**LEGEND:**

SCR SHOTCRETE REPAIR AREA

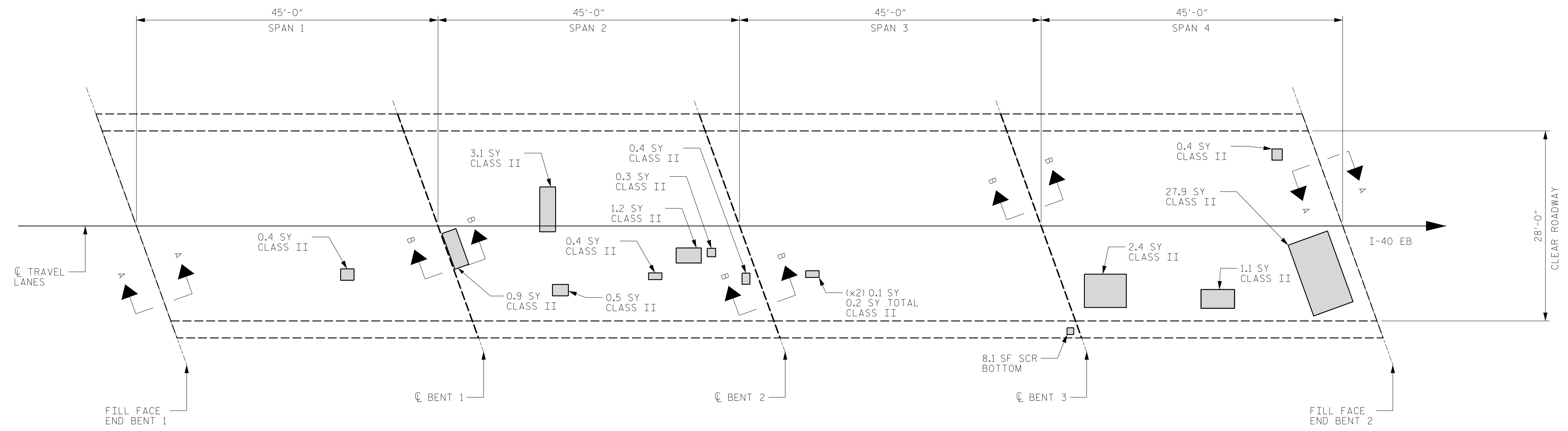
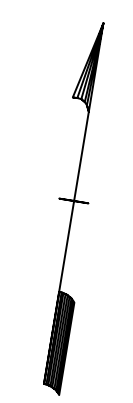

**NOTES:**

PRIOR TO SURFACE PREPARATION, REMOVE ALL LOOSE, DISINTEGRATED, UNSOUND OR CONTAMINATED CONCRETE FROM THE BRIDGE DECK.  
 BRIDGE DECK SHOTBLASTING AND SILANE SEAL LIMITS ARE THE FULL CLEAR ROADWAY WIDTH (INSIDE FACE OF EACH BRIDGE RAIL).  
 FOR CONCRETE FOR DECK REPAIR, SEE SPECIAL PROVISIONS.  
 FOR SILANE DECK TREATMENT AND SHOTBLASTING BRIDGE DECK, SEE SPECIAL PROVISIONS.  
 REPAIR LOCATIONS AND ESTIMATED QUANTITIES ARE GIVEN WITH THE BEST INFORMATION AVAILABLE. IF ADDITIONAL REPAIRS NOT SHOWN ON THE DRAWINGS ARE DEEMED NECESSARY BY THE ENGINEER, THE ENGINEER WILL NOTE ON THE DRAWINGS THE APPROXIMATE LOCATIONS AND DESCRIPTION OF THE REPAIRS AND ADJUST THE ACTUAL QUANTITIES ENTERED INTO THE AS-BUILT REPAIR QUANTITY TABLE.

SILANE SEAL DECK TREATMENT      DEFECTS (SEE PLAN CALLOUT FOR DETAILS)

DRAWN BY : ALLEN J. MCSWAIN      DATE : 01/2022  
 CHECKED BY : JACOB H. DUKE      DATE : 01/2022  
 DESIGN ENGINEER OF RECORD: DIEGO A. AGUIRRE      DATE : 01/2022

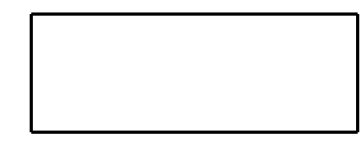

PROJECT NO. I-5915B  
CATAWBA COUNTY  
 BRIDGE NO. 170177

SHEET 1 OF 2

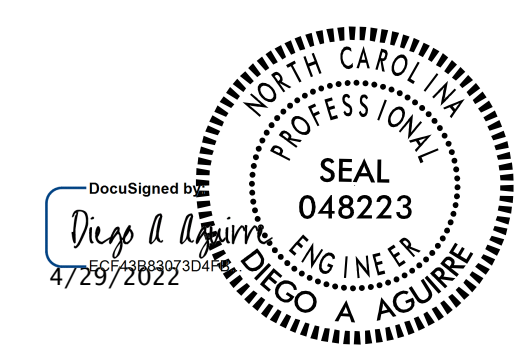

STATE OF NORTH CAROLINA  
 DEPARTMENT OF TRANSPORTATION  
 RALEIGH

## PLAN OF SPANS DECK REPAIRS



DOCUMENT NOT CONSIDERED  
 FINAL UNLESS ALL  
 SIGNATURES COMPLETED

REVISIONS						SHEET NO.
NO.	BY:	DATE:	NO.	BY:	DATE:	
1			3			S3-3
2			4			TOTAL SHEETS 11



# AS-BUILT REPAIR QUANTITY TABLE

	SPAN 1		SPAN 2		SPAN 3		SPAN 4	
	ESTIMATE	ACTUAL	ESTIMATE	ACTUAL	ESTIMATE	ACTUAL	ESTIMATE	ACTUAL
ASPHALT CONCRETE SURFACE COURSE, TYPE S9.5C	16 TON		16 TON		16 TON		16 TON	
ASPHALT BINDER FOR PLANT MIX	1.0 TON		1.0 TON		1.0 TON		1.0 TON	

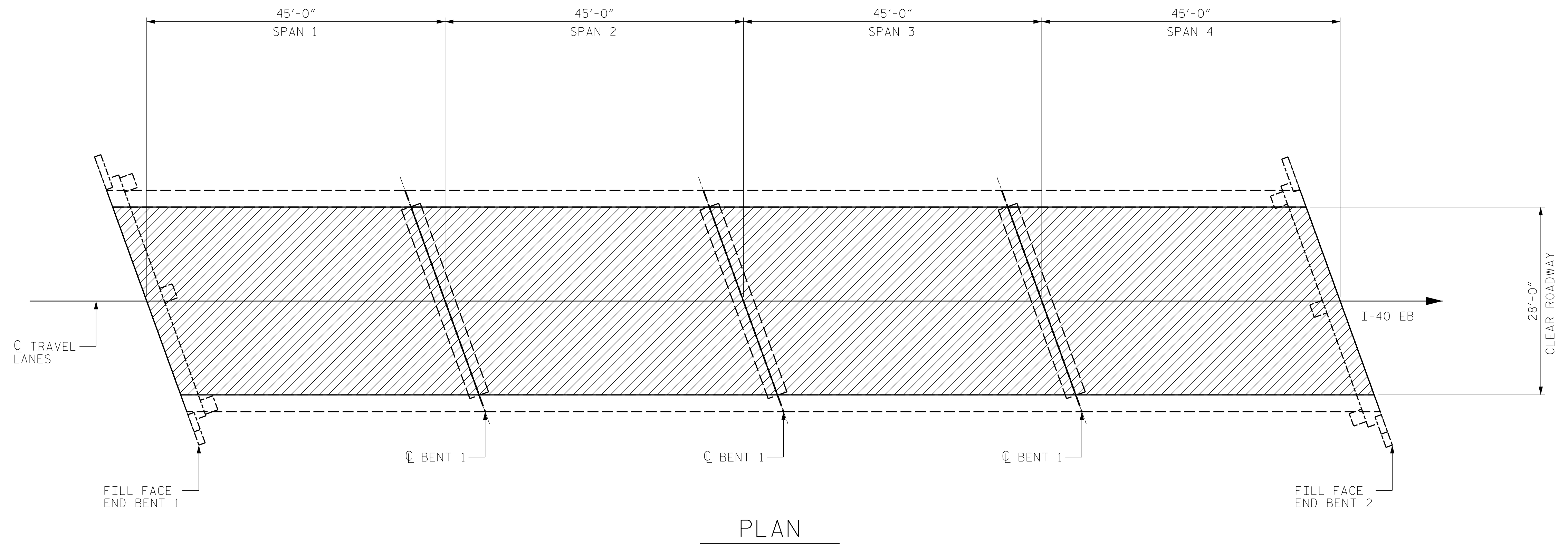

**NOTES:**

- WORK THIS SHEET WITH "JOINT DETAILS" SHEET.
- WORK THIS SHEET WITH "TYPICAL SECTION" SHEET.
- WORK THIS SHEET WITH "DECK REPAIR DETAILS" SHEET.
- FOR NEW ASPHALT PLACEMENT, SEE STANDARD SPECIFICATIONS.

 ASPHALT CONCRETE SURFACE COURSE, TYPE S9.5C

DRAWN BY : FIDEL L. FLORES DATE : 01/2022  
 CHECKED BY : JACOB H. DUKE DATE : 01/2022  
 DESIGN ENGINEER OF RECORD: DIEGO A. AGUIRRE DATE : 01/2022

4/21/2022  
 I5915B.SMU.DSR02.170177.dgn  
 daquirre

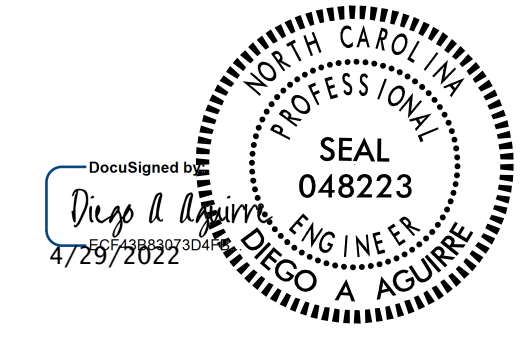

DOCUMENT NOT CONSIDERED FINAL UNLESS ALL SIGNATURES COMPLETED

PROJECT NO. I-5915B  
CATAWBA COUNTY  
 BRIDGE NO. 170177  
 SHEET 2 OF 2

STATE OF NORTH CAROLINA DEPARTMENT OF TRANSPORTATION RALEIGH					
PLAN OF SPANS ASPHALT WEARING SURFACE					
REVISIONS					
NO.	BY:	DATE:	NO.	BY:	DATE:
1			3		
2			4		
SHEET NO.					S3-4
TOTAL SHEETS					11



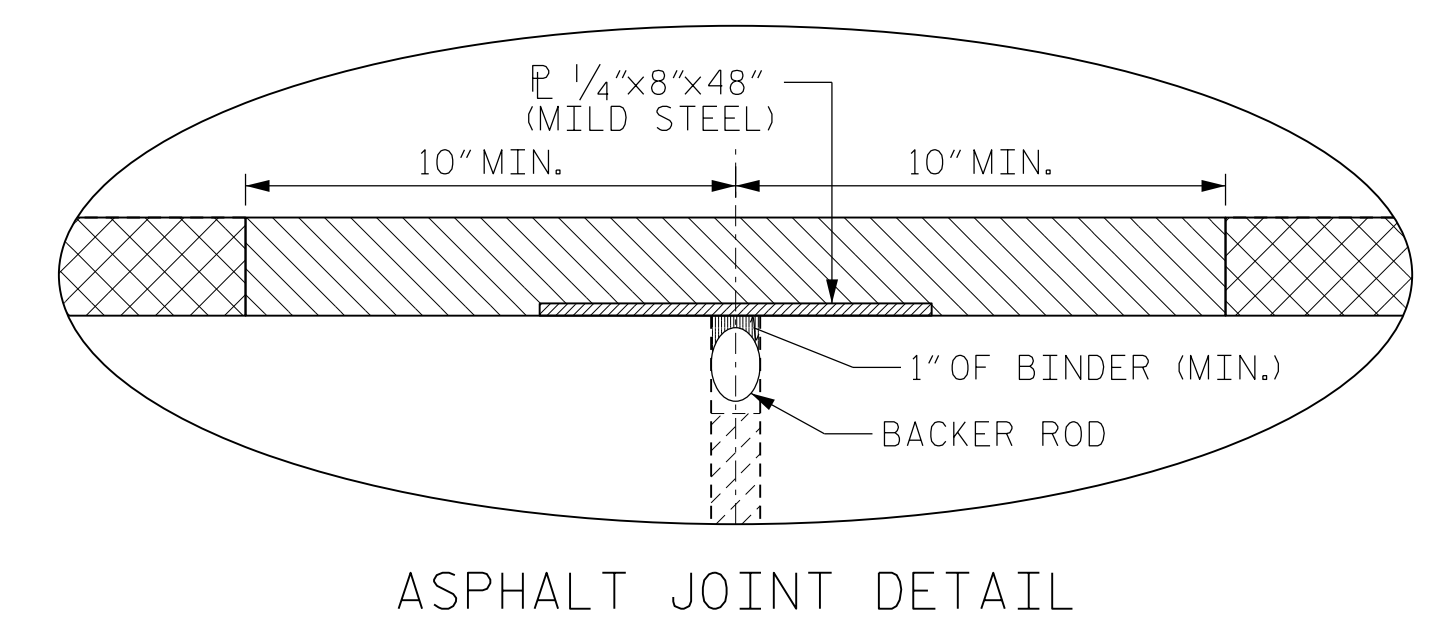
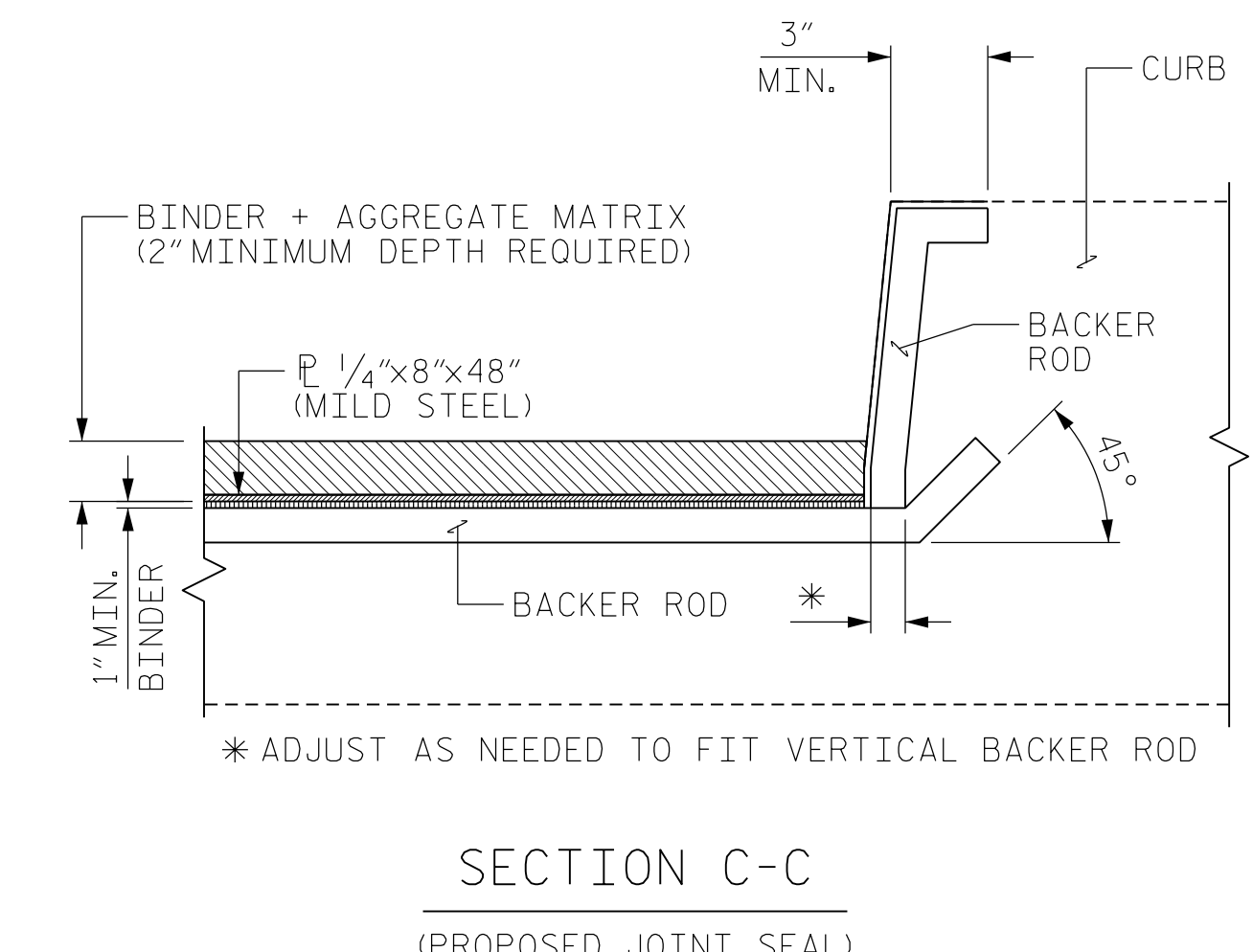
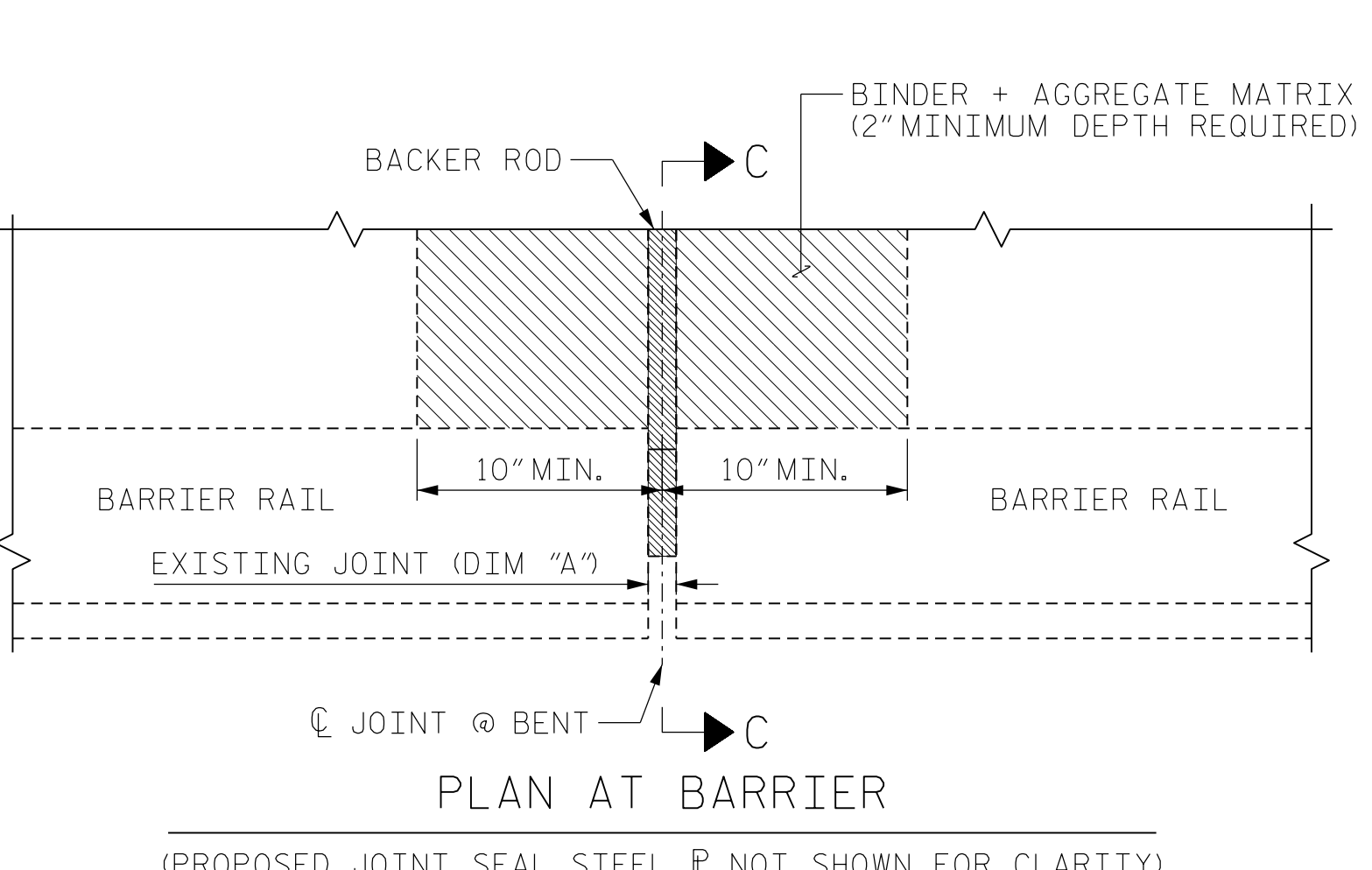
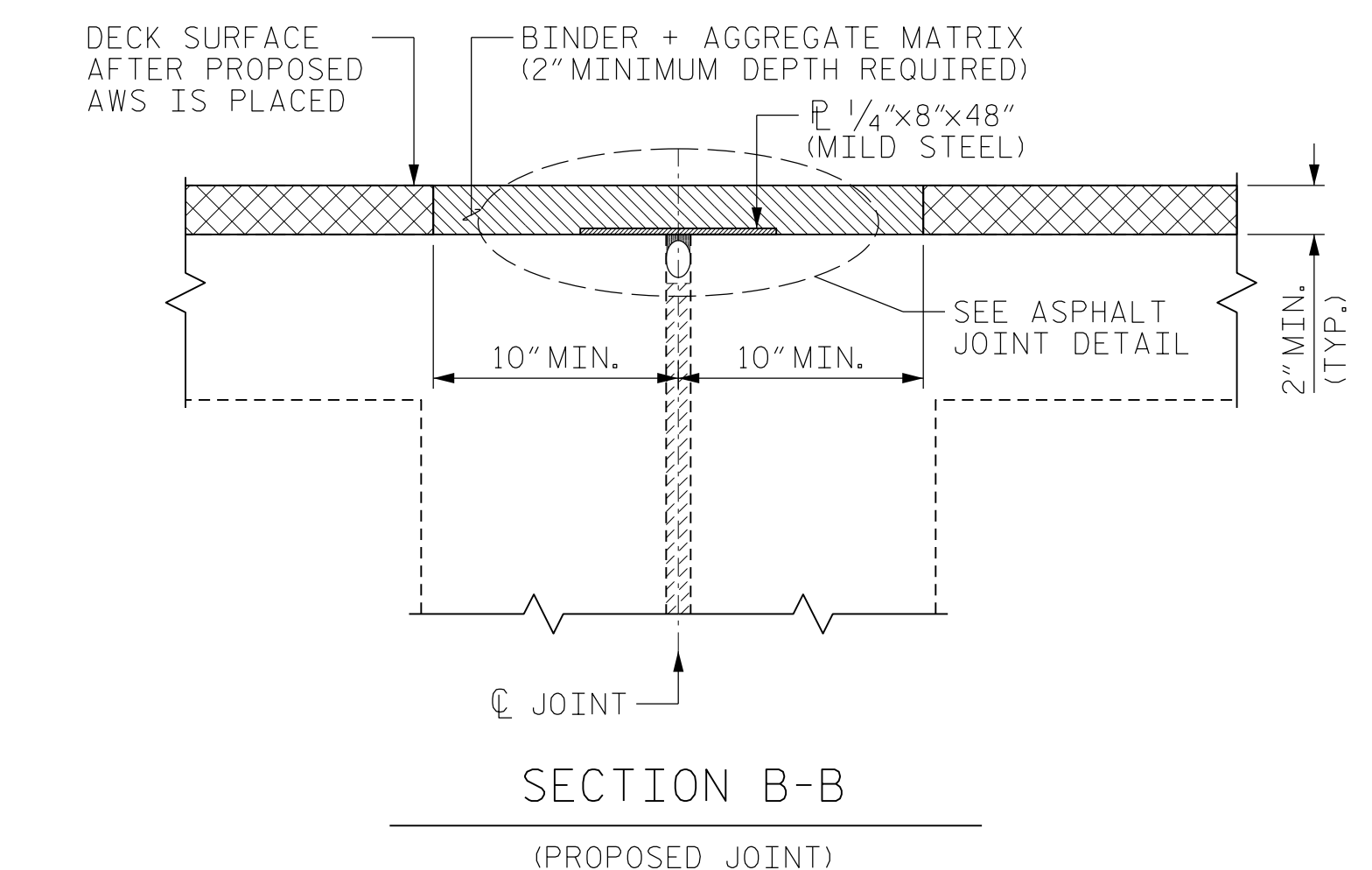
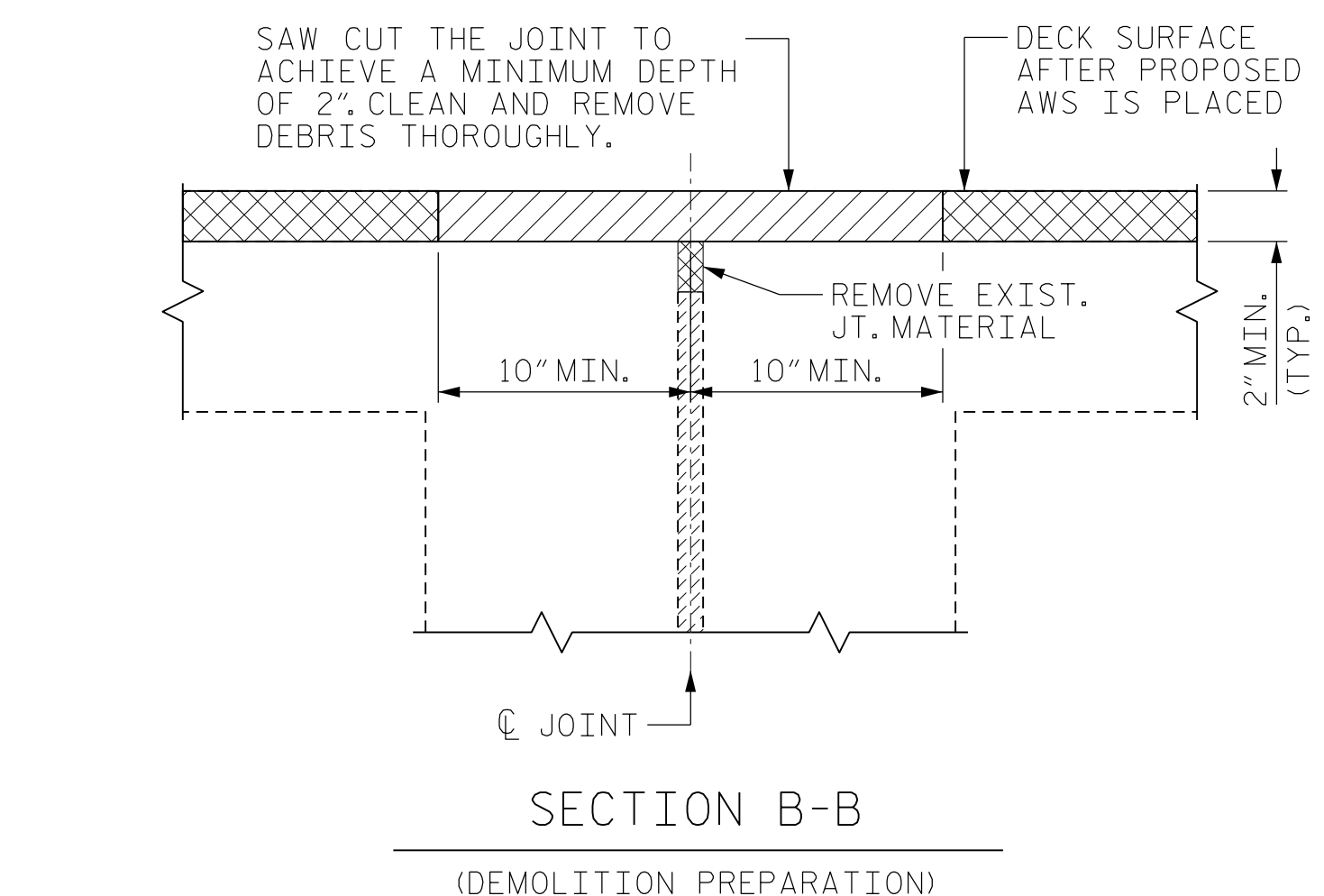
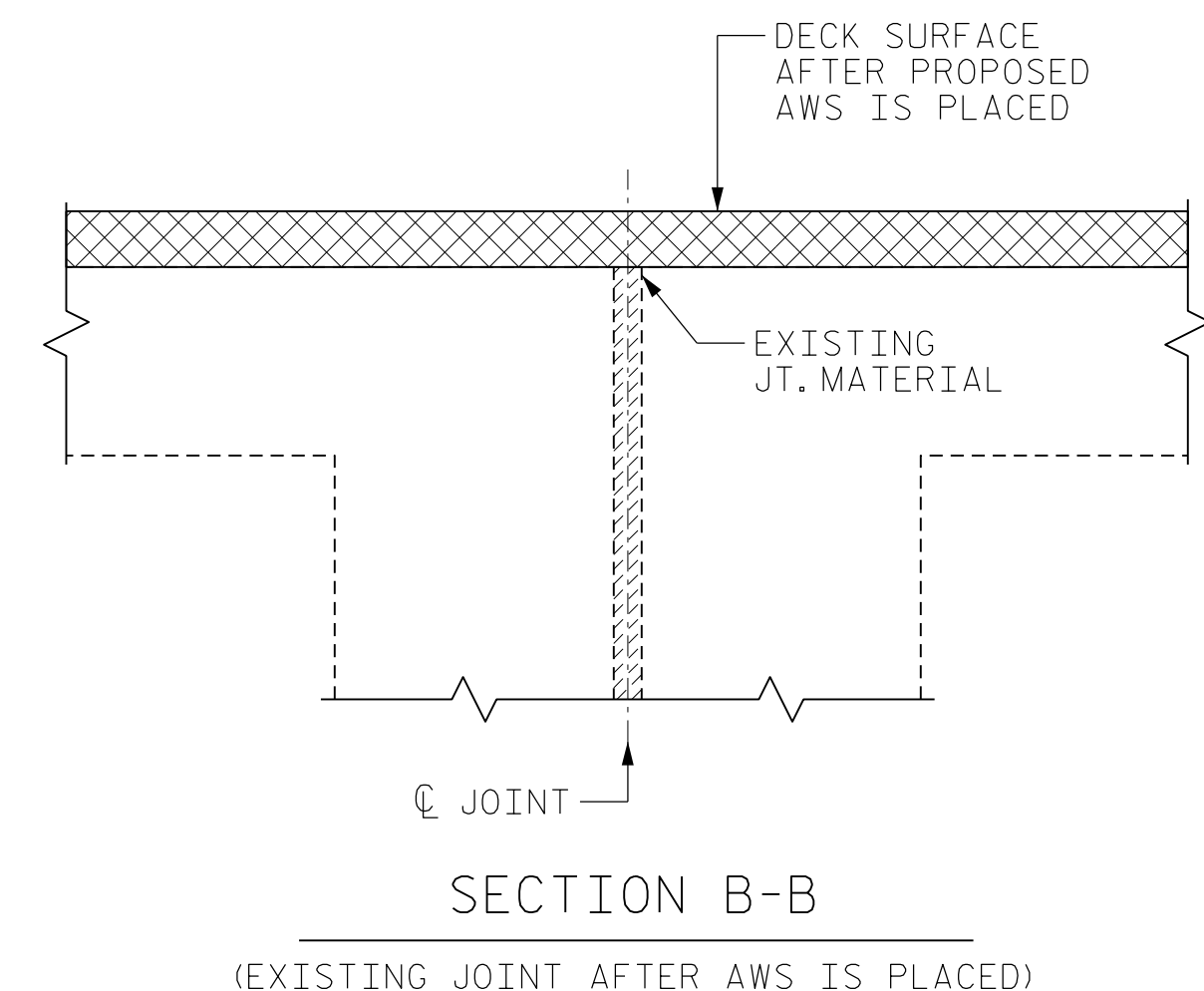
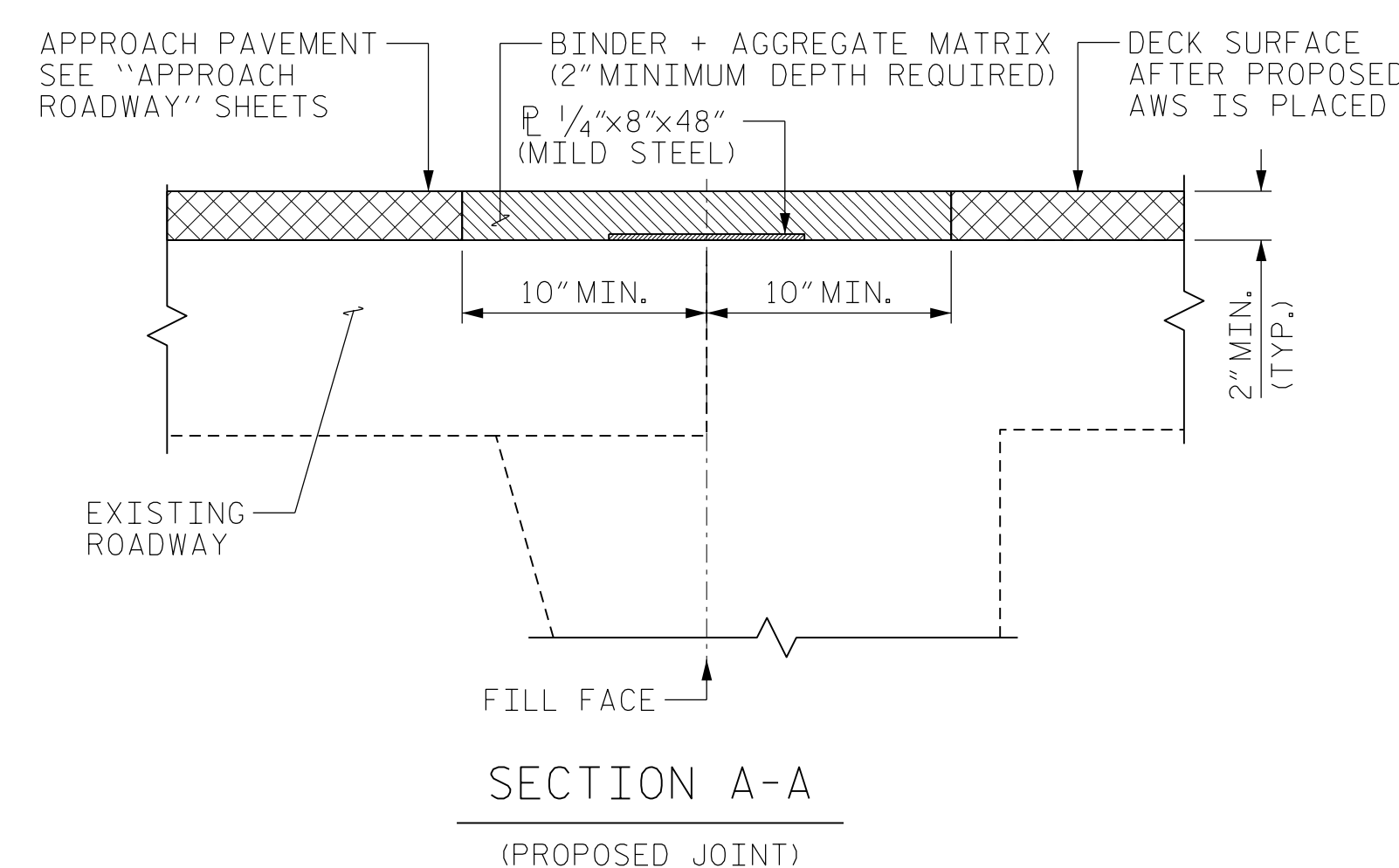
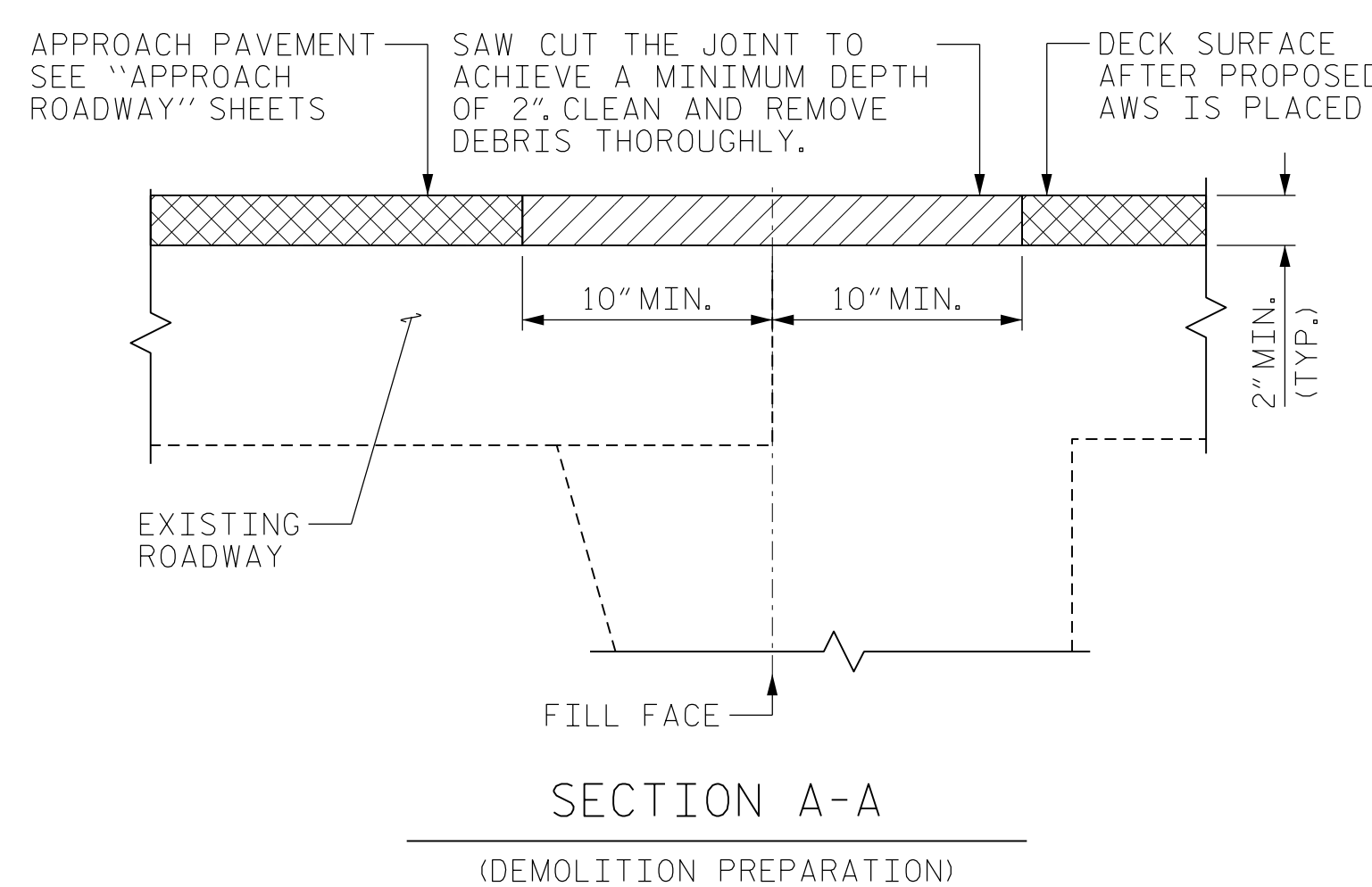
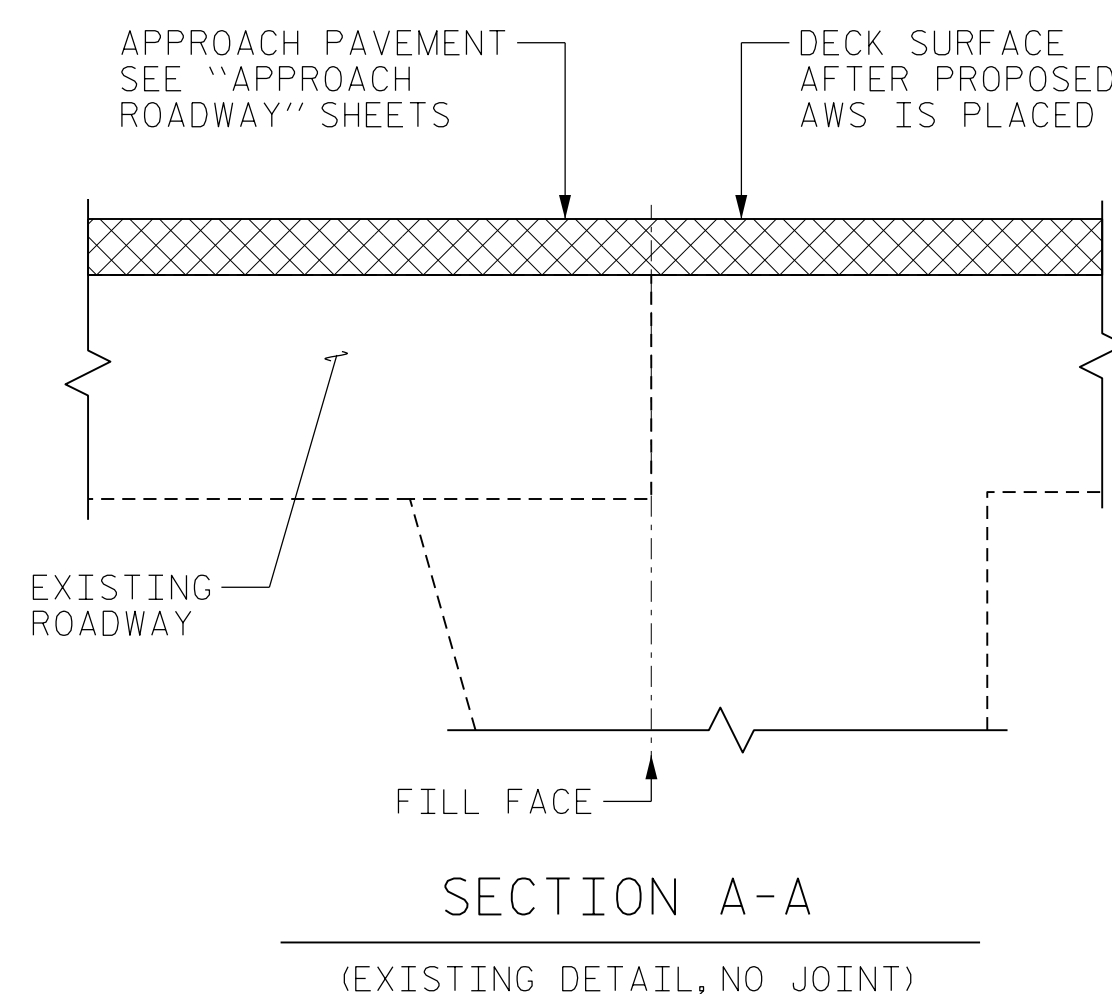

NOTES:

THE CONTRACTOR SHALL FIELD VERIFY THE EXISTING JOINT OPENING PRIOR TO ORDERING JOINT SEAL MATERIAL. IF THE ACTUAL OPENING VARIES FROM THE OPENING INDICATED IN THE DETAIL BY MORE THAN 1/4", NOTIFY THE ENGINEER. REVISION OF THE JOINT SEAL SIZE MIGHT BE NECESSARY.

THE CONTRACTOR SHALL TAKE CARE DURING JOINT REPAIR OPERATIONS NOT TO DROP ANY MATERIAL THAT FALLS BELOW THE BRIDGE, WITHOUT PROTECTIVE DEVICES BELOW TO CATCH THE MATERIAL. ANY MATERIAL THAT FALLS BELOW THE BRIDGE SHALL BE CONTAINED, REMOVED AND DISPOSED OF BY THE CONTRACTOR AT NO EXTRA COST TO THE DEPARTMENT. IF THE ENGINEER DETERMINES THAT THE PROTECTIVE DEVICES ARE NOT ADEQUATE OR NOT BEING EMPLOYED, THE WORK SHALL BE SUSPENDED UNTIL ADEQUATE PROTECTION IS PROVIDED.

THE CONTRACTOR WILL NOT BE PERMITTED TO FORM THE JOINTS IN LIEU OF SAWING THE JOINT.

THE INSTALLED BACKER ROD AND SILICONE SEALANT SHALL BE WATER TIGHT.

FOR EXCAVATION BELOW THE BOTTOM OF THE PLANNED JOINT DECK DEMOLITION, CONCRETE FOR DECK REPAIRS SHALL BE PLACED IN THE EXCAVATED AREA TO THE ELEVATION AT BOTTOM OF THE PROPOSED ASPHALT JOINT DETAIL SHOWN.

DEMOLISH BRIDGE JOINT AREA SUCH THAT THE BOTTOM OF THE EXCAVATION SHALL BE REASONABLY FLAT AND LEVEL AND TO THE NECESSARY DEPTH, SUCH THAT ASPHALT JOINT SHALL BE FOUNDED ON CONCRETE OR REPAIR CONCRETE SUBSTRATE.

PRIOR TO ASPHALT JOINT REPAIR/REPLACEMENT, PERFORM DECK SURFACE REPAIRS IN ACCORDANCE WITH "PLAN OF SPAN" SHEETS.

BACKER ROD SHALL BE INSTALLED AS PER MANUFACTURER'S RECOMMENDATIONS.

FOR ASPHALT JOINT REPAIR/REPLACEMENT, SEE SPECIAL PROVISIONS.

FOR CONCRETE FOR DECK REPAIR, SEE SPECIAL PROVISIONS.

PROPOSED JOINT QUANTITY		
	ESTIMATED (LIN.FT.)	ACTUAL (LIN.FT.)
ASPHALT JOINT REPAIR/REPLACEMENT	156.4	

PROJECT NO. I-5915B  
 CATAWBA COUNTY  
 BRIDGE NO. 170177

BENT/ JOINTS	DIM "A" @ 60°F
END BENT 1	1 1/2"
1	1"
2	1"
3	1"
END BENT 2	3/4"

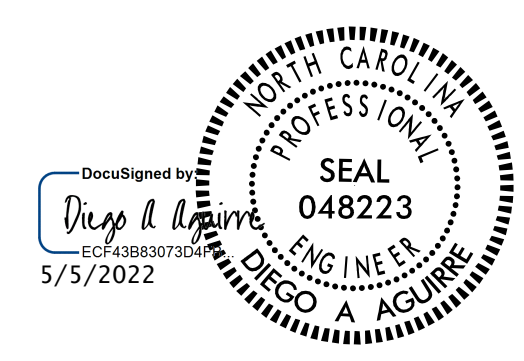

STATE OF NORTH CAROLINA  
 DEPARTMENT OF TRANSPORTATION  
 RALEIGH

JOINT DETAILS

REVISIONS						SHEET NO.
NO.	BY:	DATE:	NO.	BY:	DATE:	
1			3			S3-5
2			4			TOTAL SHEETS 11

DRAWN BY : DIEGO A. AGUIRRE DATE : 01/2022  
 CHECKED BY : JACOB H. DUKE DATE : 01/2022  
 DESIGN ENGINEER OF RECORD: DIEGO A. AGUIRRE DATE : 01/2022

DOCUMENT NOT CONSIDERED FINAL UNLESS ALL SIGNATURES COMPLETED

# AS-BUILT REPAIR QUANTITY TABLE

	ESTIMATE	ACTUAL
INCIDENTAL MILLING	1402 SY	
ASPHALT CONCRETE SURFACE COURSE, TYPE S9.5C	197 TON	
ASPHALT BINDER FOR PLANT MIX	11.9 TON	

## NOTES:

INCIDENTAL MILLING - EXISTING APPROACH ASPHALT PAVEMENT TO BE MILLED AS NECESSARY TO ATTAIN MINIMUM 1/2" DEPTH OF NEW ASPHALT PAVEMENT. NEW ASPHALT PAVEMENT SHALL BE OF THICKNESS NECESSARY TO PROVIDE A SMOOTH TRANSITION BETWEEN THE ROADWAY AND THE BRIDGE DECK. THE NEW ASPHALT PAVEMENT THICKNESS MAY EXCEED 1/2" DUE TO SETTLEMENT OF THE EXISTING APPROACH.

FOR NEW ASPHALT PLACEMENT, SEE STANDARD SPECIFICATIONS.

GRADE MAY BE ADJUSTED BY THE ENGINEER TO ENSURE PROPER TIE-IN AT THE END BENTS.

**C1** PROPOSED VARIABLE DEPTH ASPHALT CONCRETE SURFACE COURSE, TYPE S9.5C AT AN AVERAGE RATE OF 112 LBS. PER SQ. YD. PER 1" DEPTH. TO BE PLACED IN LAYERS NOT LESS THAN 1" OR GREATER THAN 2" IN DEPTH.

INCIDENTAL MILLING

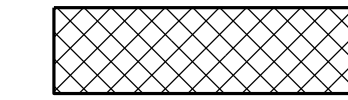

ASPHALT CONCRETE SURFACE COURSE, TYPE S9.5C (C1)

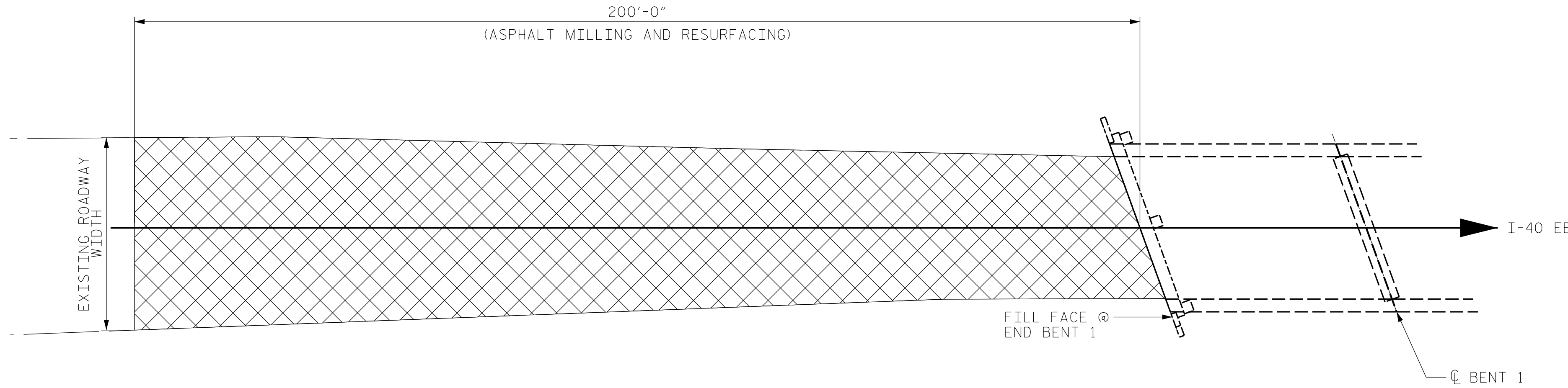
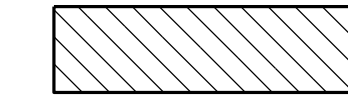

BEGIN APPROACH SLAB

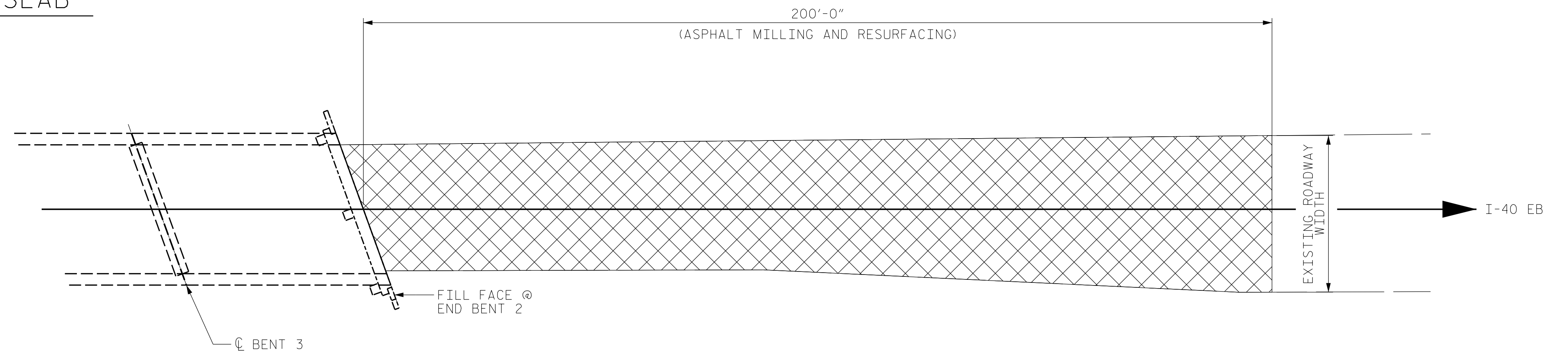

END APPROACH SLAB

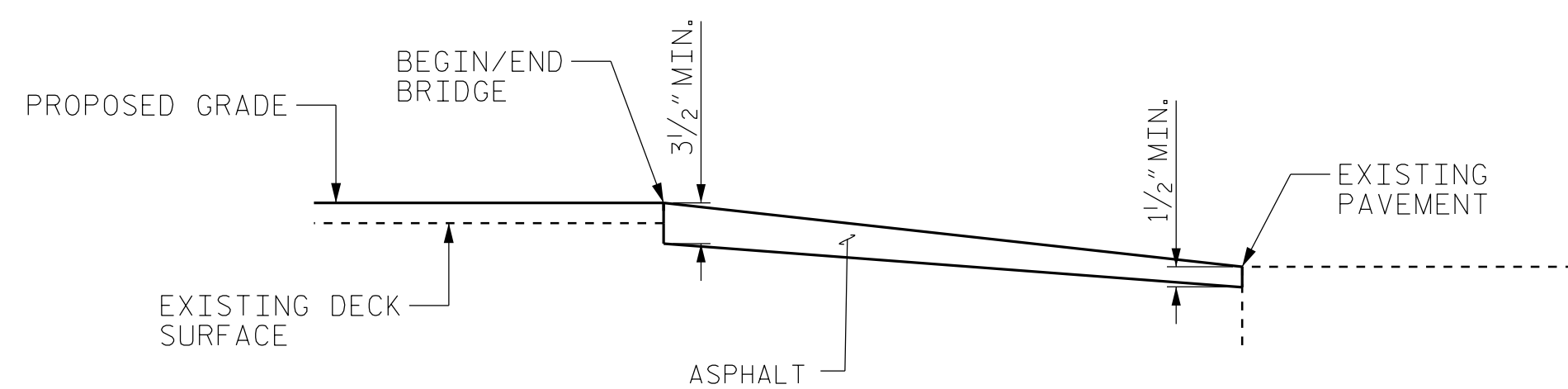

PAVEMENT KEY-IN DETAIL FOR BOTH END BENTS

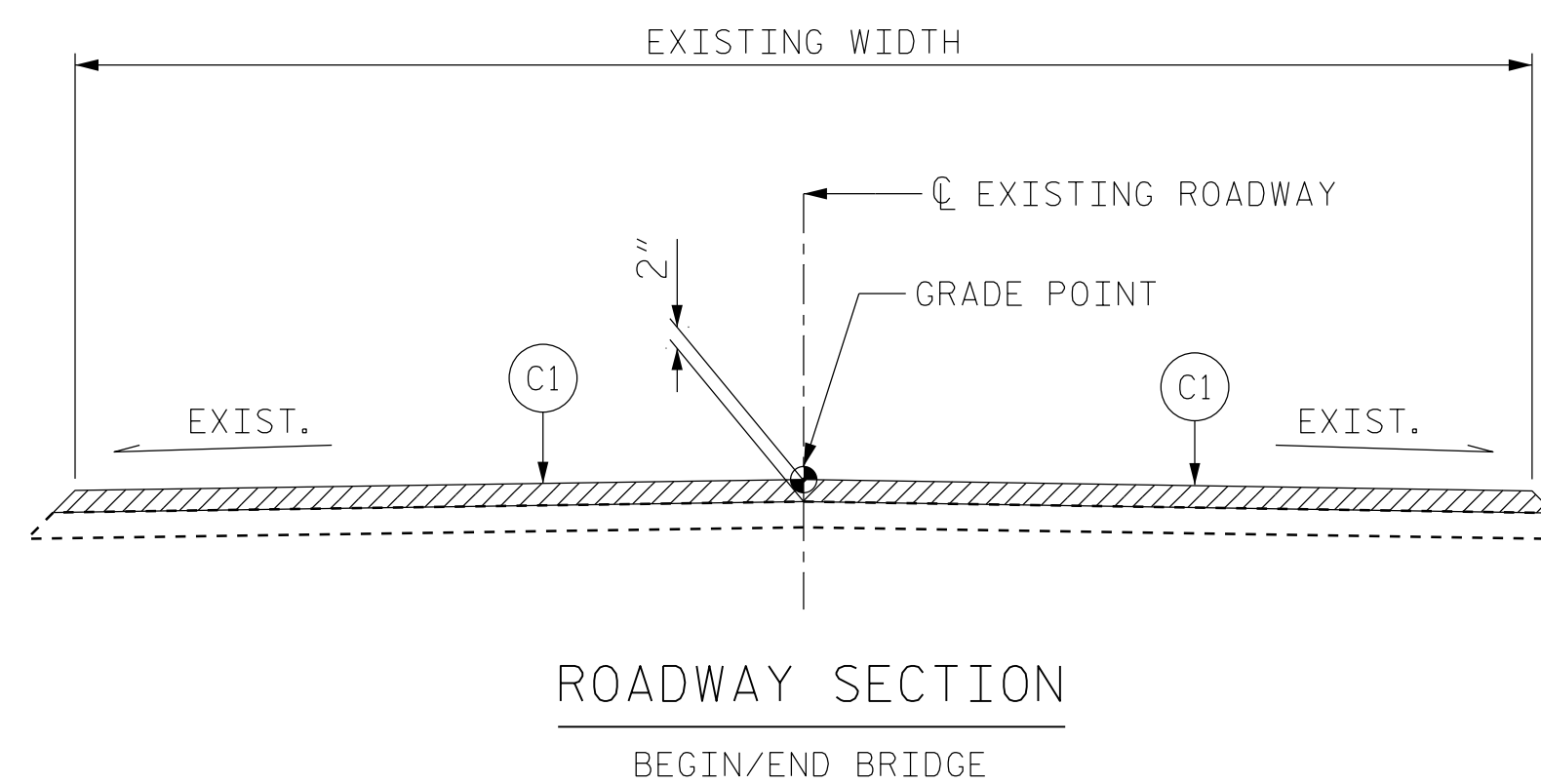

ROADWAY SECTION  
BEGIN/END BRIDGE

PROJECT NO. I-5915B  
CATAWBA COUNTY  
 BRIDGE NO. 170177



STATE OF NORTH CAROLINA  
 DEPARTMENT OF TRANSPORTATION  
 RALEIGH  
 APPROACH ROADWAY  
 MILLING AND RESURFACING

DRAWN BY : FIDEL L. FLORES DATE : 01/2022  
 CHECKED BY : JACOB H. DUKE DATE : 01/2022  
 DESIGN ENGINEER OF RECORD: DIEGO A. AGUIRRE DATE : 01/2022

4/21/2022  
 I5915B\_SMU\_AR01.170177.dgn  
 daguirre

DOCUMENT NOT CONSIDERED  
 FINAL UNLESS ALL  
 SIGNATURES COMPLETED

REVISIONS						SHEET NO.
NO.	BY:	DATE:	NO.	BY:	DATE:	
1			3			S3-6
2			4			TOTAL SHEETS 11



# AS-BUILT REPAIR QUANTITY TABLE

## SUPERSTRUCTURE REPAIRS

	SPAN 1				SPAN 2				SPAN 3				SPAN 4			
	ESTIMATE		ACTUAL		ESTIMATE		ACTUAL		ESTIMATE		ACTUAL		ESTIMATE		ACTUAL	
	AREA	VOLUME	AREA	VOLUME	AREA	VOLUME	AREA	VOLUME	AREA	VOLUME	AREA	VOLUME	AREA	VOLUME	AREA	VOLUME
CONCRETE REPAIR AREA (CR)	2.5 SF	0.9 CF			26.2 SF	8.9 CF			36.2 SF	17.0 CF			18.0 SF	8.0 CF		
SHOTCRETE REPAIR AREA (SCR)	-- SF	-- CF			-- SF	-- CF			-- SF	-- CF			-- SF	-- CF		
	ESTIMATE		ACTUAL		ESTIMATE		ACTUAL		ESTIMATE		ACTUAL		ESTIMATE		ACTUAL	
CLEANING & PAINTING EXISTING BEARINGS WITH HRSCA	4 EA				8 EA				8 EA				4 EA			

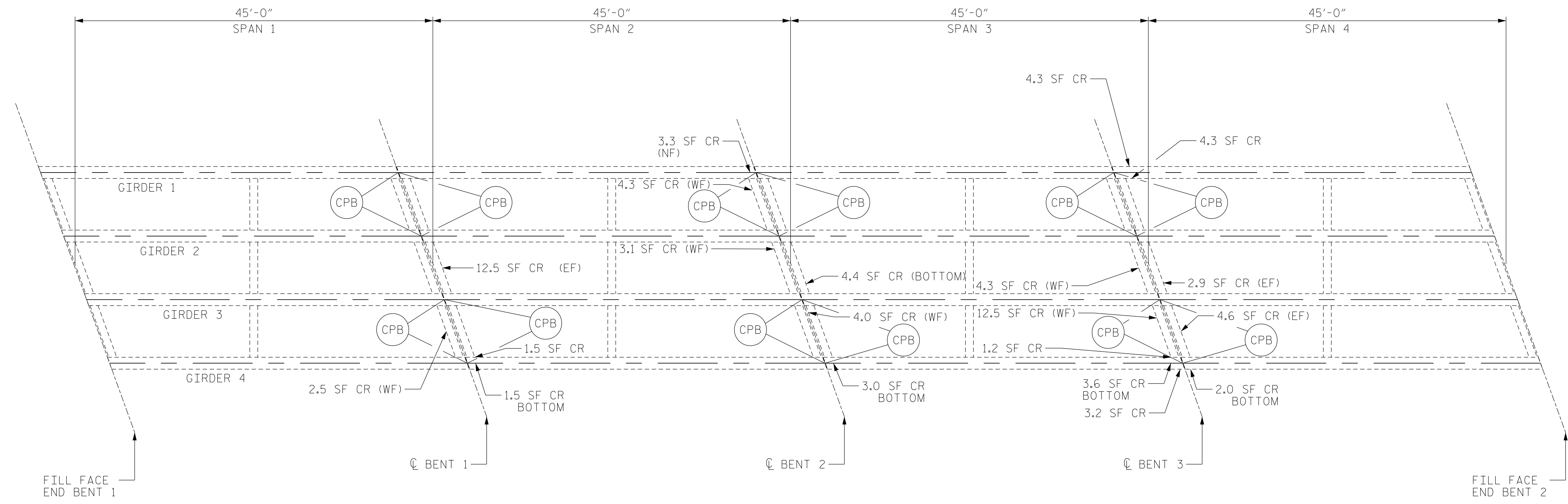

**NOTES:**

REPAIR LOCATIONS AND ESTIMATED QUANTITIES ARE GIVEN WITH THE BEST INFORMATION AVAILABLE. IF ADDITIONAL REPAIRS NOT SHOWN ON THE DRAWINGS ARE DEEMED NECESSARY BY THE ENGINEER, THE ENGINEER WILL NOTE ON THE DRAWINGS THE APPROXIMATE LOCATIONS AND DESCRIPTION OF THE REPAIRS AND ADJUST THE ACTUAL QUANTITIES ENTERED INTO THE TABLE ABOVE.

CRACKING LOCATIONS AND QUANTITIES FOR LOCATIONS DESCRIBED AS "SCATTERED THROUGHOUT" IN THE INSPECTION REPORT ARE BASED ON THE BEST INFORMATION AVAILABLE. THE ENGINEER AND CONTRACTOR SHALL IDENTIFY AND REPAIR ALL CRACKS  $\geq \frac{1}{16}$ " AS DESCRIBED IN THE SPECIAL PROVISIONS AT EACH BENT.

FOR CONCRETE AND SHOTCRETE REPAIRS, SEE "CONCRETE RESTORATION DETAILS" SHEETS.

SHOTCRETE REPAIRS MAY BE REPLACED WITH CONCRETE REPAIRS WITH THE APPROVAL OF THE ENGINEER.

**LEGEND:**

- CR CONCRETE REPAIR
- SCR SHOTCRETE REPAIR
- (CPB) CLEAN AND PAINT BEARINGS
- NF NORTH FACE
- SF SOUTH FACE
- WF WEST FACE
- EF EAST FACE

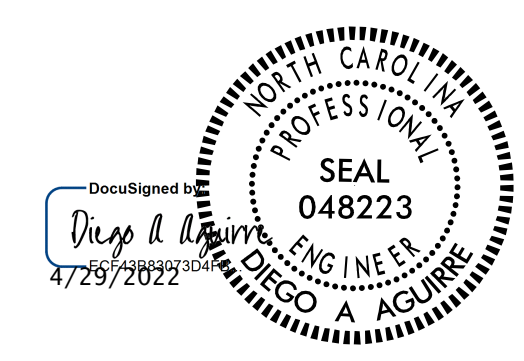

PROJECT NO. I-5915B  
CATAWBA COUNTY  
 BRIDGE NO. 170177



STATE OF NORTH CAROLINA DEPARTMENT OF TRANSPORTATION RALEIGH					
SUPERSTRUCTURE REPAIRS					
REVISIONS					
NO.	BY:	DATE:	NO.	BY:	DATE:
1			3		
2			4		
					SHEET NO. S3-7 TOTAL SHEETS 11

DRAWN BY : ALLEN J. MCSWAIN	DATE : 01/2022
CHECKED BY : JACOB H. DUKE	DATE : 01/2022
DESIGN ENGINEER OF RECORD: DIEGO A. AGUIRRE	DATE : 01/2022

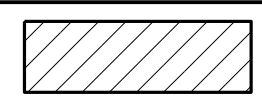
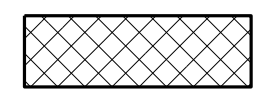
DOCUMENT NOT CONSIDERED FINAL UNLESS ALL SIGNATURES COMPLETED

LEGEND	
	CONCRETE REPAIR AREA (CR)
	SHOTCRETE REPAIR AREA (SCR)
	EPOXY RESIN INJECTION (ERI)

	AS-BUILT REPAIR QUANTITY TABLE			
	ESTIMATE		ACTUAL	
SHOTCRETE REPAIRS	AREA SQ. FT.	VOLUME CU. FT.	AREA SQ. FT.	VOLUME CU. FT.
	CAP/BACKWALL	6.0	2.1	
COLUMN/PILE	-	-		
CONCRETE REPAIRS	AREA SQ. FT.	VOLUME CU. FT.	AREA SQ. FT.	VOLUME CU. FT.
	CAP	12.4	6.5	
EPOXY RESIN INJECTION	LIN. FT.		LIN. FT.	
	CAP/BACKWALL	7.6		
COLUMN/PILE	-			

VALUES IN CHART REPRESENT ESTIMATED REPAIR TOTALS AFTER REMOVAL OF UNSOUND CONCRETE. MINIMUM OF 1" BEHIND REBAR AND MINIMUM 2" CLEARANCE TO SAWCUT. FOR REPAIR DETAILS, SEE "CONCRETE RESTORATION DETAILS" SHEETS.

**NOTES:**  
 REPAIR LOCATIONS AND ESTIMATED QUANTITIES ARE GIVEN WITH THE BEST INFORMATION AVAILABLE. IF ADDITIONAL REPAIRS NOT SHOWN ON THE DRAWINGS ARE DEEMED NECESSARY BY THE ENGINEER, THE ENGINEER WILL NOTE ON THE DRAWINGS THE APPROXIMATE LOCATIONS AND DESCRIPTION OF THE REPAIRS AND ADJUST THE ACTUAL QUANTITIES ENTERED INTO THE TABLE ABOVE.

CRACKING LOCATIONS AND QUANTITIES FOR LOCATIONS DESCRIBED AS "SCATTERED THROUGHOUT" IN THE INSPECTION REPORT ARE BASED ON THE BEST INFORMATION AVAILABLE. THE ENGINEER AND CONTRACTOR SHALL IDENTIFY AND REPAIR ALL CRACKS  $\geq 1/16"$  AS DESCRIBED IN THE SPECIAL PROVISIONS AT EACH BENT.

AVERAGE CONCRETE COVER IS EXPECTED TO BE FROM 2" TO 3" ON THE CAP AND FROM 1 1/2" TO 2" ON THE PILES. ACTUAL CONCRETE COVER SHALL BE DETERMINED BY THE CONTRACTOR AND PRESENTED TO THE ENGINEER PRIOR TO BEGINNING EXCAVATION/ DEMOLITION.

FOR CONCRETE AND SHOTCRETE REPAIRS, SEE "CONCRETE RESTORATION DETAILS" SHEETS.

SHOTCRETE REPAIRS MAY BE REPLACED WITH CONCRETE REPAIRS WITH THE APPROVAL OF THE ENGINEER.

REPAIRS TO THE BENT CAP MAY REQUIRE BRIDGE JACKING. FOR BRIDGE JACKING, SEE SPECIAL PROVISIONS.

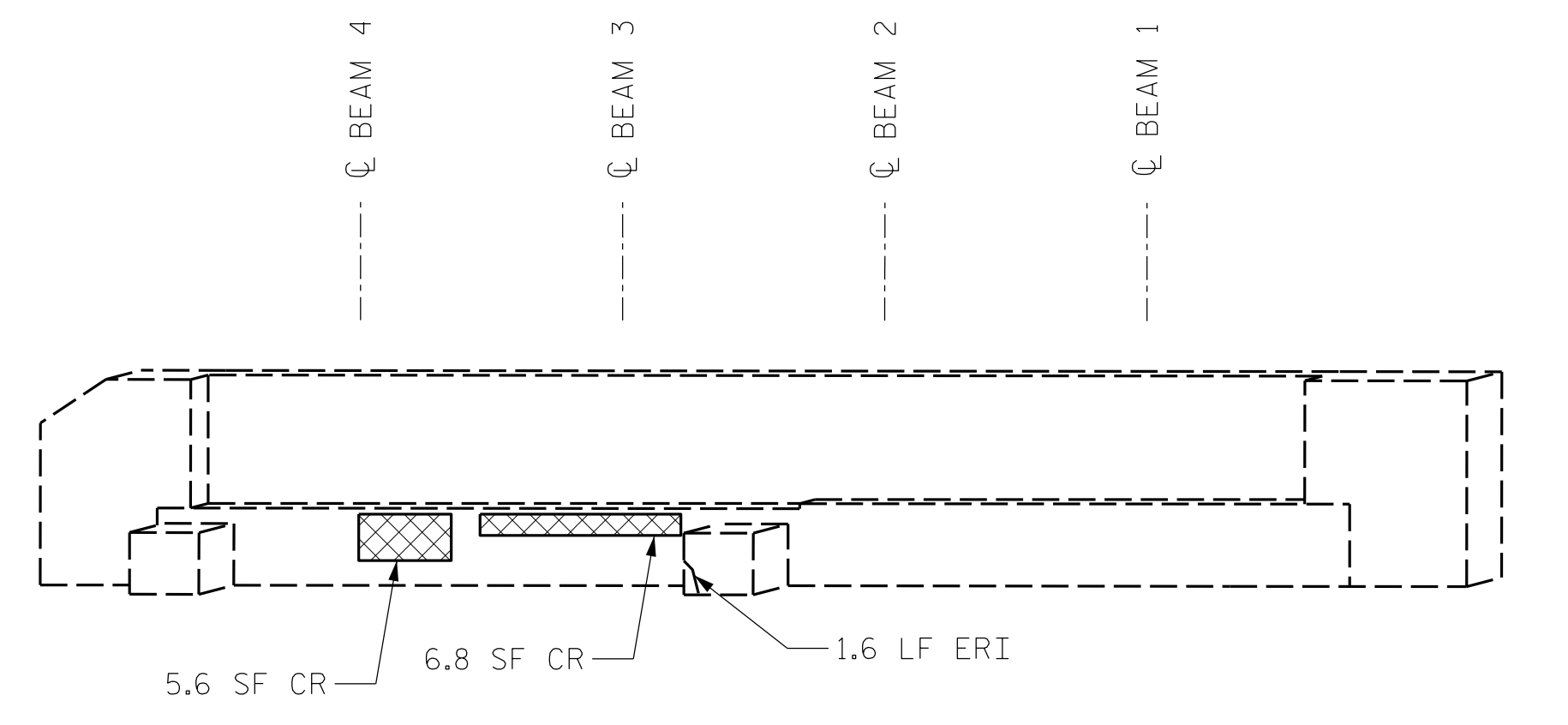

END BENT 1  
(EAST FACE)

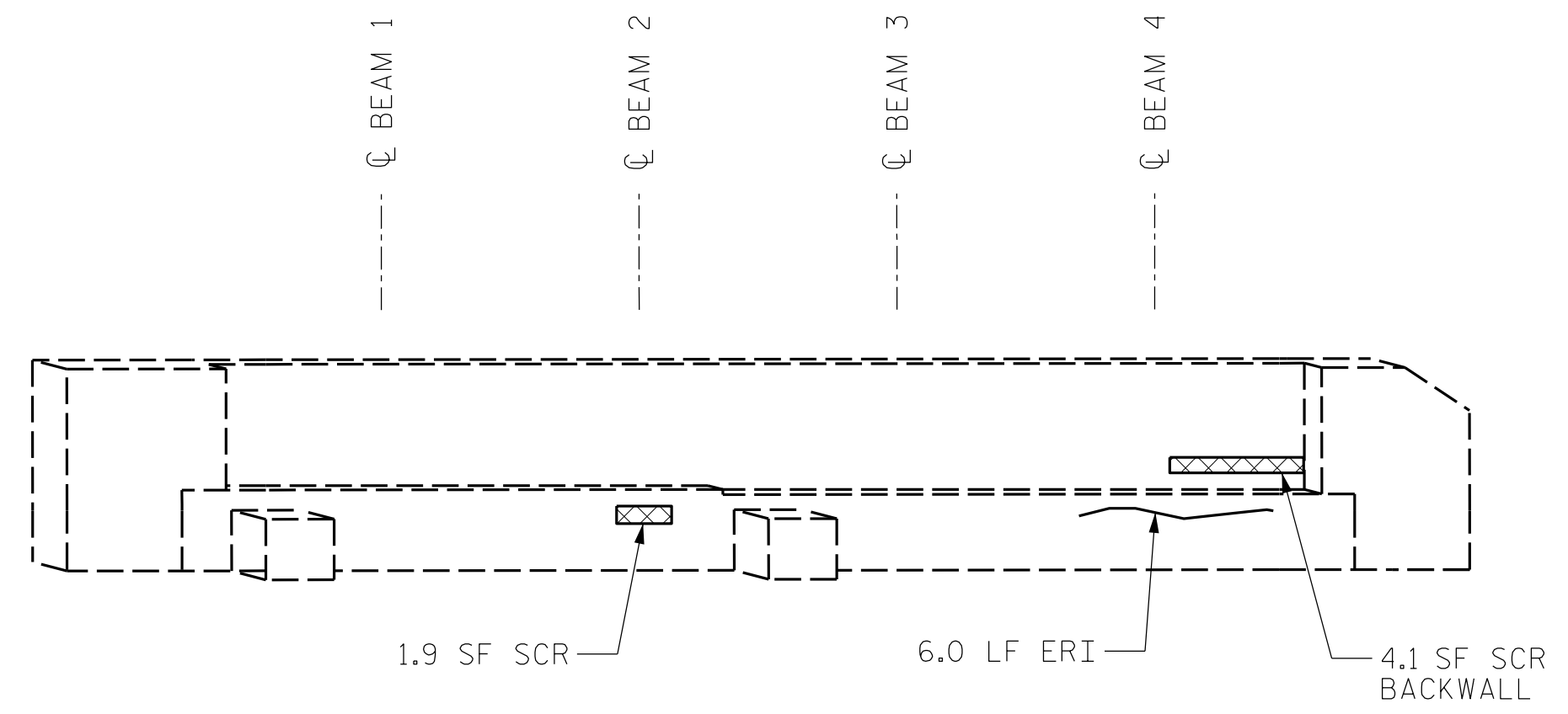

END BENT 2  
(WEST FACE)

PROJECT NO. I-5915B  
CATAWBA COUNTY  
 BRIDGE NO. 170177

SHEET 1 OF 4

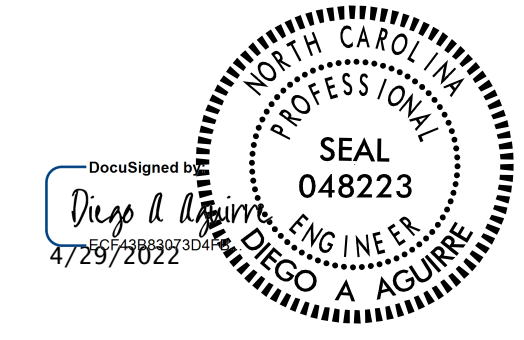

STATE OF NORTH CAROLINA  
 DEPARTMENT OF TRANSPORTATION  
 RALEIGH  
**SUBSTRUCTURE REPAIRS**  
 END BENTS 1 & 2

DRAWN BY : ALLEN J. MCSWAIN DATE : 01/2022  
 CHECKED BY : FIDEL L. FLORES DATE : 01/2022  
 DESIGN ENGINEER OF RECORD: DIEGO A. AGUIRRE DATE : 01/2022

DOCUMENT NOT CONSIDERED FINAL UNLESS ALL SIGNATURES COMPLETED

REVISIONS						SHEET NO.
NO.	BY:	DATE:	NO.	BY:	DATE:	
1			3			S3-8
2			4			TOTAL SHEETS 11



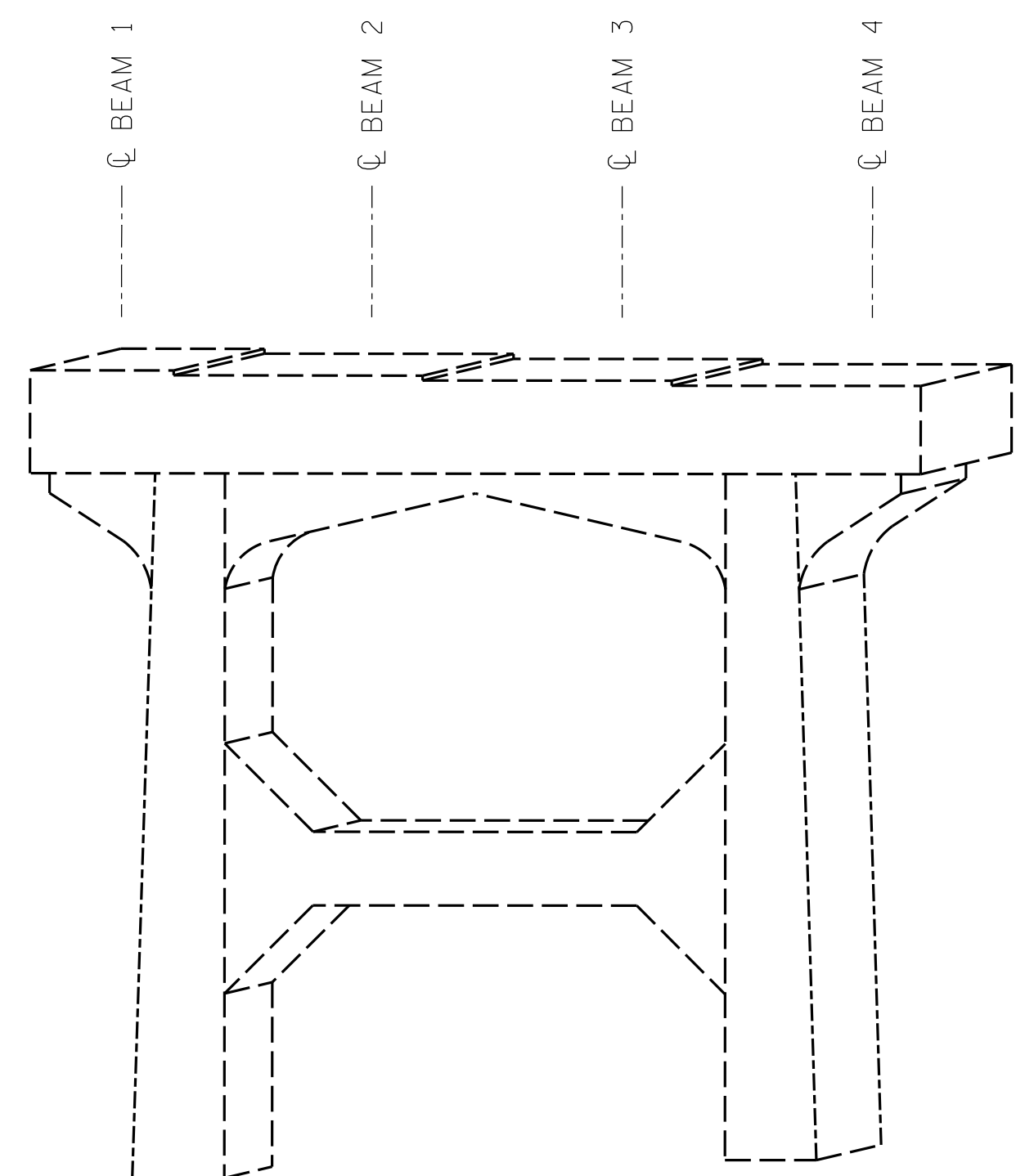

BENT 1  
(WEST FACE)

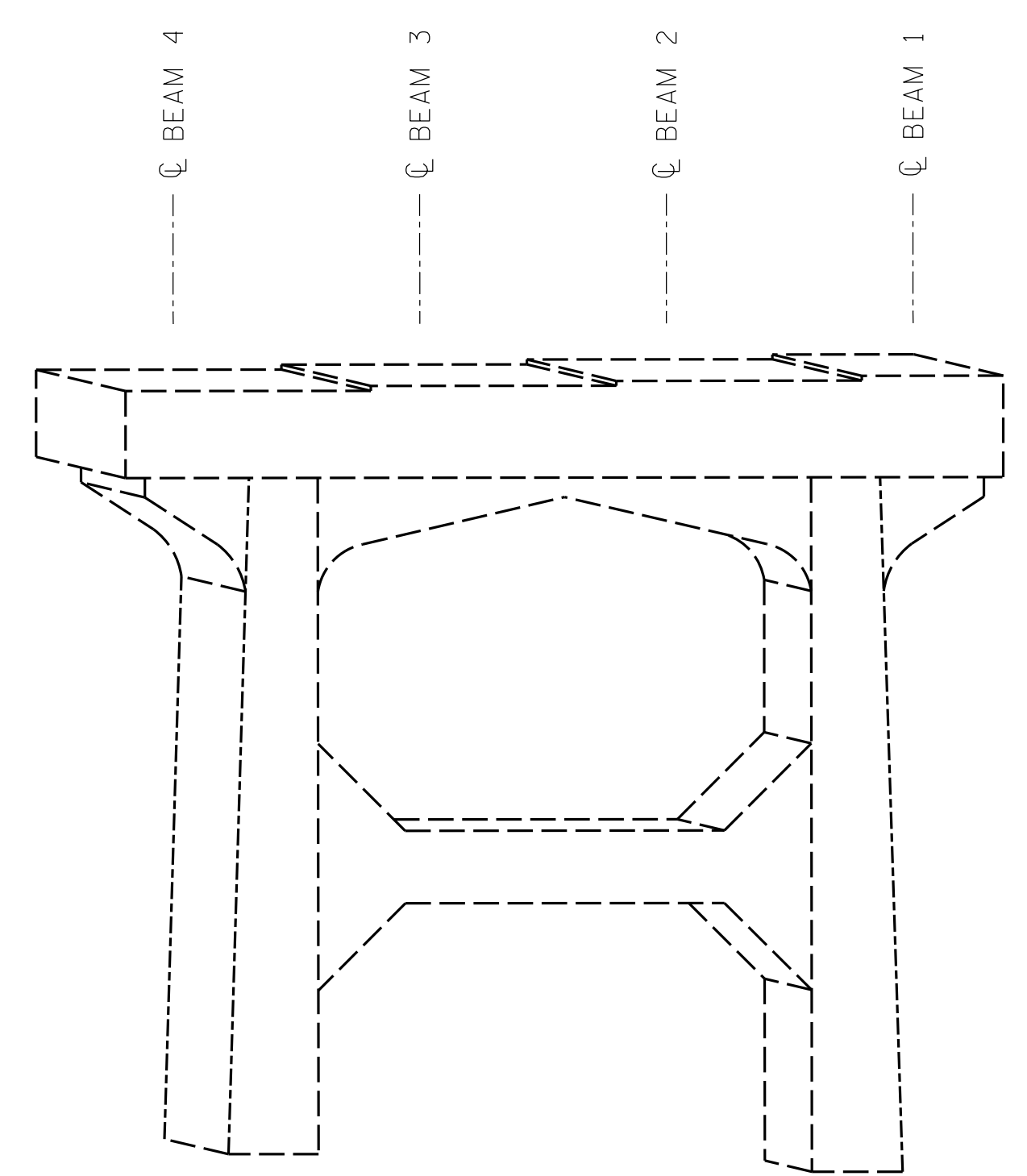

BENT 1  
(EAST FACE)

LEGEND	
	CONCRETE REPAIR AREA (CR)
	SHOTCRETE REPAIR AREA (SCR)
	EPOXY RESIN INJECTION (ERI)

		AS-BUILT REPAIR QUANTITY TABLE			
		ESTIMATE		ACTUAL	
SHOTCRETE REPAIRS		AREA SQ. FT.	VOLUME CU. FT.	AREA SQ. FT.	VOLUME CU. FT.
CAP/BACKWALL		-	-		
COLUMN/PILE		-	-		
CONCRETE REPAIRS		AREA SQ. FT.	VOLUME CU. FT.	AREA SQ. FT.	VOLUME CU. FT.
CAP		-	-		
EPOXY RESIN INJECTION		LIN. FT.		LIN. FT.	
CAP/BACKWALL		-			
COLUMN/PILE		-			

VALUES IN CHART REPRESENT ESTIMATED REPAIR TOTALS AFTER REMOVAL OF UNSOUND CONCRETE. MINIMUM OF 1" BEHIND REBAR AND MINIMUM 2" CLEARANCE TO SAWCUT. FOR REPAIR DETAILS, SEE "CONCRETE RESTORATION DETAILS" SHEETS.

**NOTES:**

REPAIR LOCATIONS AND ESTIMATED QUANTITIES ARE GIVEN WITH THE BEST INFORMATION AVAILABLE. IF ADDITIONAL REPAIRS NOT SHOWN ON THE DRAWINGS ARE DEEMED NECESSARY BY THE ENGINEER, THE ENGINEER WILL NOTE ON THE DRAWINGS THE APPROXIMATE LOCATIONS AND DESCRIPTION OF THE REPAIRS AND ADJUST THE ACTUAL QUANTITIES ENTERED INTO THE TABLE ABOVE.

CRACKING LOCATIONS AND QUANTITIES FOR LOCATIONS DESCRIBED AS "SCATTERED THROUGHOUT" IN THE INSPECTION REPORT ARE BASED ON THE BEST INFORMATION AVAILABLE. THE ENGINEER AND CONTRACTOR SHALL IDENTIFY AND REPAIR ALL CRACKS  $\geq 1/16"$  AS DESCRIBED IN THE SPECIAL PROVISIONS AT EACH BENT.

AVERAGE CONCRETE COVER IS EXPECTED TO BE FROM 2" TO 3" ON THE CAP AND FROM 1 1/2" TO 2" ON THE PILES. ACTUAL CONCRETE COVER SHALL BE DETERMINED BY THE CONTRACTOR AND PRESENTED TO THE ENGINEER PRIOR TO BEGINNING EXCAVATION/ DEMOLITION.

FOR CONCRETE AND SHOTCRETE REPAIRS, SEE "CONCRETE RESTORATION DETAILS" SHEETS.

SHOTCRETE REPAIRS MAY BE REPLACED WITH CONCRETE REPAIRS WITH THE APPROVAL OF THE ENGINEER.

REPAIRS TO THE BENT CAP MAY REQUIRE BRIDGE JACKING. FOR BRIDGE JACKING, SEE SPECIAL PROVISIONS.

PROJECT NO. I-5915B  
CATAWBA COUNTY  
 BRIDGE NO. 170177

SHEET 2 OF 4

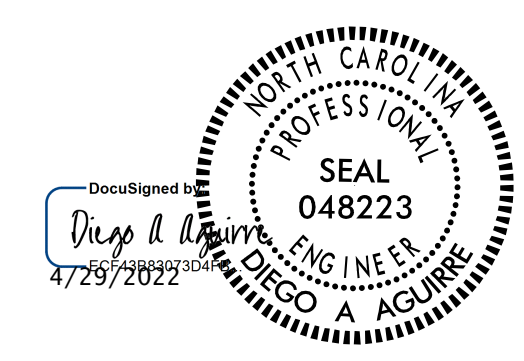

STATE OF NORTH CAROLINA  
 DEPARTMENT OF TRANSPORTATION  
 RALEIGH  
**SUBSTRUCTURE REPAIRS**  
 BENT 1

DRAWN BY : ALLEN J. MCSWAIN DATE : 01/2022  
 CHECKED BY : FIDEL L. FLORES DATE : 01/2022  
 DESIGN ENGINEER OF RECORD: DIEGO A. AGUIRRE DATE : 01/2022

DOCUMENT NOT CONSIDERED FINAL UNLESS ALL SIGNATURES COMPLETED

REVISIONS						SHEET NO.
NO.	BY:	DATE:	NO.	BY:	DATE:	
1			3			S3-9
2			4			TOTAL SHEETS 11

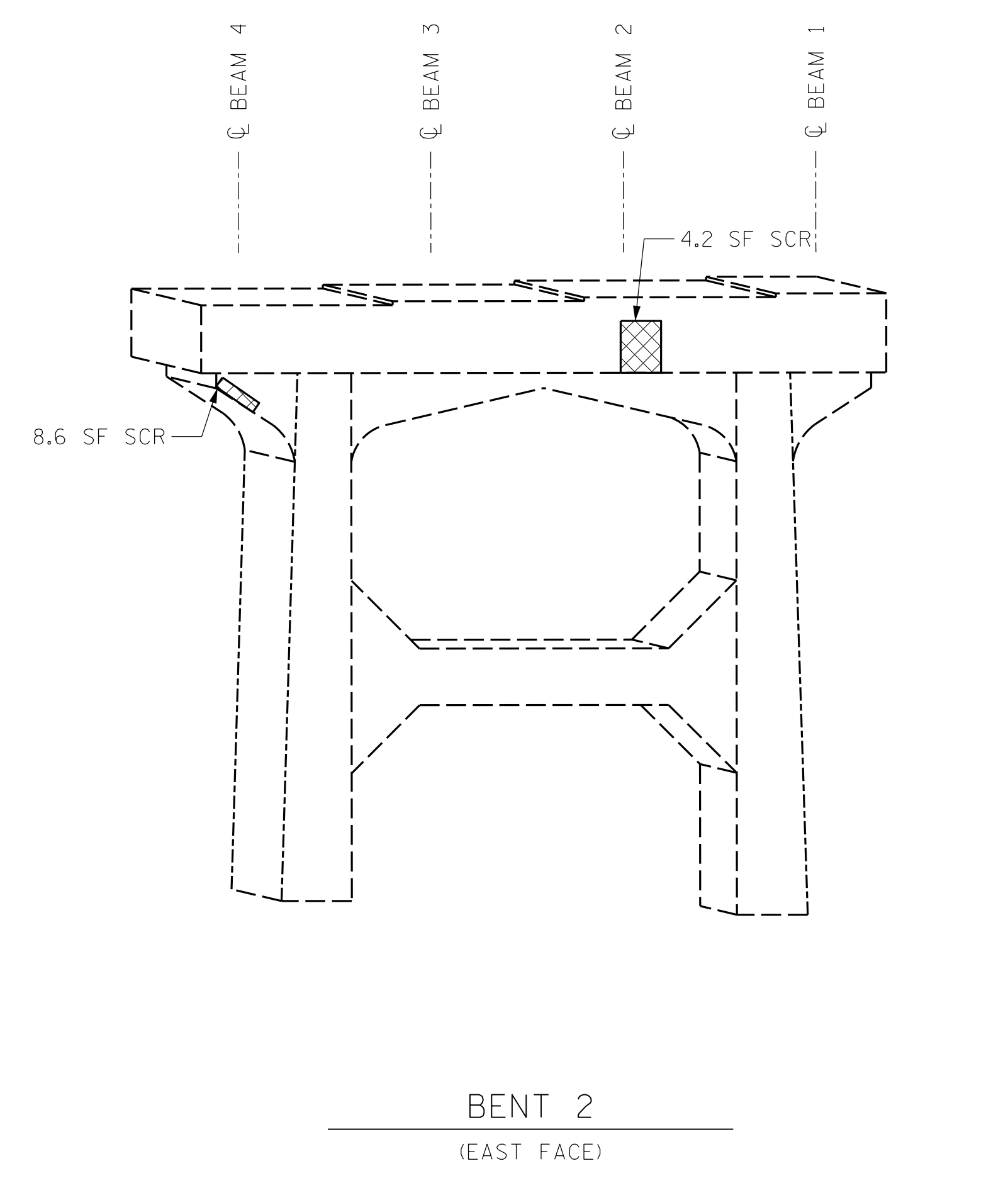
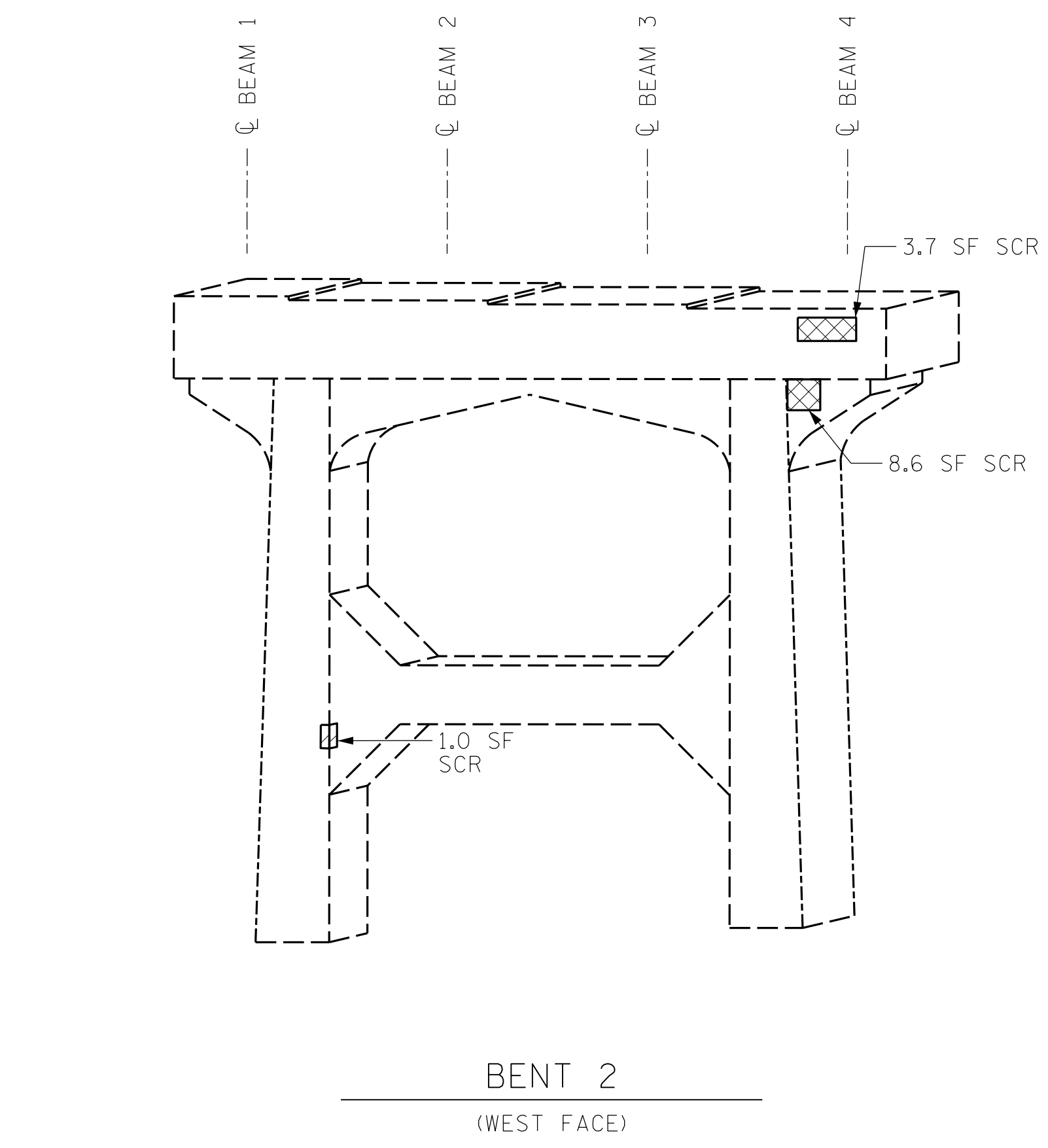

LEGEND	
	CONCRETE REPAIR AREA (CR)
	SHOTCRETE REPAIR AREA (SCR)
	EPOXY RESIN INJECTION (ERI)

	AS-BUILT REPAIR QUANTITY TABLE			
	ESTIMATE		ACTUAL	
SHOTCRETE REPAIRS	AREA SQ. FT.	VOLUME CU. FT.	AREA SQ. FT.	VOLUME CU. FT.
CAP/BACKWALL	25.1	8.5		
COLUMN/PILE	1.0	0.5		
CONCRETE REPAIRS	AREA SQ. FT.	VOLUME CU. FT.	AREA SQ. FT.	VOLUME CU. FT.
CAP	-	-		
EPOXY RESIN INJECTION	LIN. FT.		LIN. FT.	
CAP/BACKWALL	-			
COLUMN/PILE	-			

VALUES IN CHART REPRESENT ESTIMATED REPAIR TOTALS AFTER REMOVAL OF UNSOUND CONCRETE. MINIMUM OF 1" BEHIND REBAR AND MINIMUM 2" CLEARANCE TO SAWCUT. FOR REPAIR DETAILS, SEE "CONCRETE RESTORATION DETAILS" SHEETS.

**NOTES:**  
REPAIR LOCATIONS AND ESTIMATED QUANTITIES ARE GIVEN WITH THE BEST INFORMATION AVAILABLE. IF ADDITIONAL REPAIRS NOT SHOWN ON THE DRAWINGS ARE DEEMED NECESSARY BY THE ENGINEER, THE ENGINEER WILL NOTE ON THE DRAWINGS THE APPROXIMATE LOCATIONS AND DESCRIPTION OF THE REPAIRS AND ADJUST THE ACTUAL QUANTITIES ENTERED INTO THE TABLE ABOVE.

CRACKING LOCATIONS AND QUANTITIES FOR LOCATIONS DESCRIBED AS "SCATTERED THROUGHOUT" IN THE INSPECTION REPORT ARE BASED ON THE BEST INFORMATION AVAILABLE. THE ENGINEER AND CONTRACTOR SHALL IDENTIFY AND REPAIR ALL CRACKS  $\geq 1/16"$  AS DESCRIBED IN THE SPECIAL PROVISIONS AT EACH BENT.

AVERAGE CONCRETE COVER IS EXPECTED TO BE FROM 2" TO 3" ON THE CAP AND FROM 1 1/2" TO 2" ON THE PILES. ACTUAL CONCRETE COVER SHALL BE DETERMINED BY THE CONTRACTOR AND PRESENTED TO THE ENGINEER PRIOR TO BEGINNING EXCAVATION/ DEMOLITION.

FOR CONCRETE AND SHOTCRETE REPAIRS, SEE "CONCRETE RESTORATION DETAILS" SHEETS.

SHOTCRETE REPAIRS MAY BE REPLACED WITH CONCRETE REPAIRS WITH THE APPROVAL OF THE ENGINEER.

REPAIRS TO THE BENT CAP MAY REQUIRE BRIDGE JACKING. FOR BRIDGE JACKING, SEE SPECIAL PROVISIONS.

PROJECT NO. I-5915B  
CATAWBA COUNTY  
 BRIDGE NO. 170177

SHEET 3 OF 4

STATE OF NORTH CAROLINA  
DEPARTMENT OF TRANSPORTATION  
RALEIGH

SUBSTRUCTURE  
REPAIRS

BENT 2

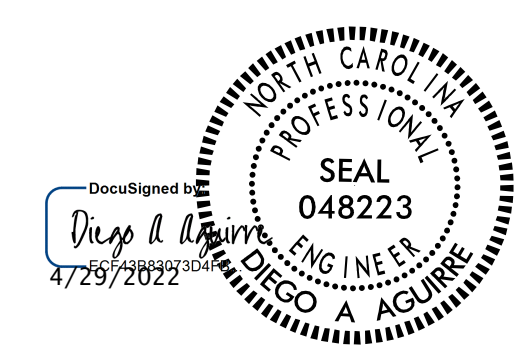

DRAWN BY : ALLEN J. MCSWAIN DATE : 01/2022  
 CHECKED BY : FIDEL L. FLORES DATE : 01/2022  
 DESIGN ENGINEER OF RECORD: DIEGO A. AGUIRRE DATE : 01/2022

DOCUMENT NOT CONSIDERED  
 FINAL UNLESS ALL  
 SIGNATURES COMPLETED

REVISIONS						SHEET NO.
NO.	BY:	DATE:	NO.	BY:	DATE:	TOTAL SHEETS
1			3			11
2			4			



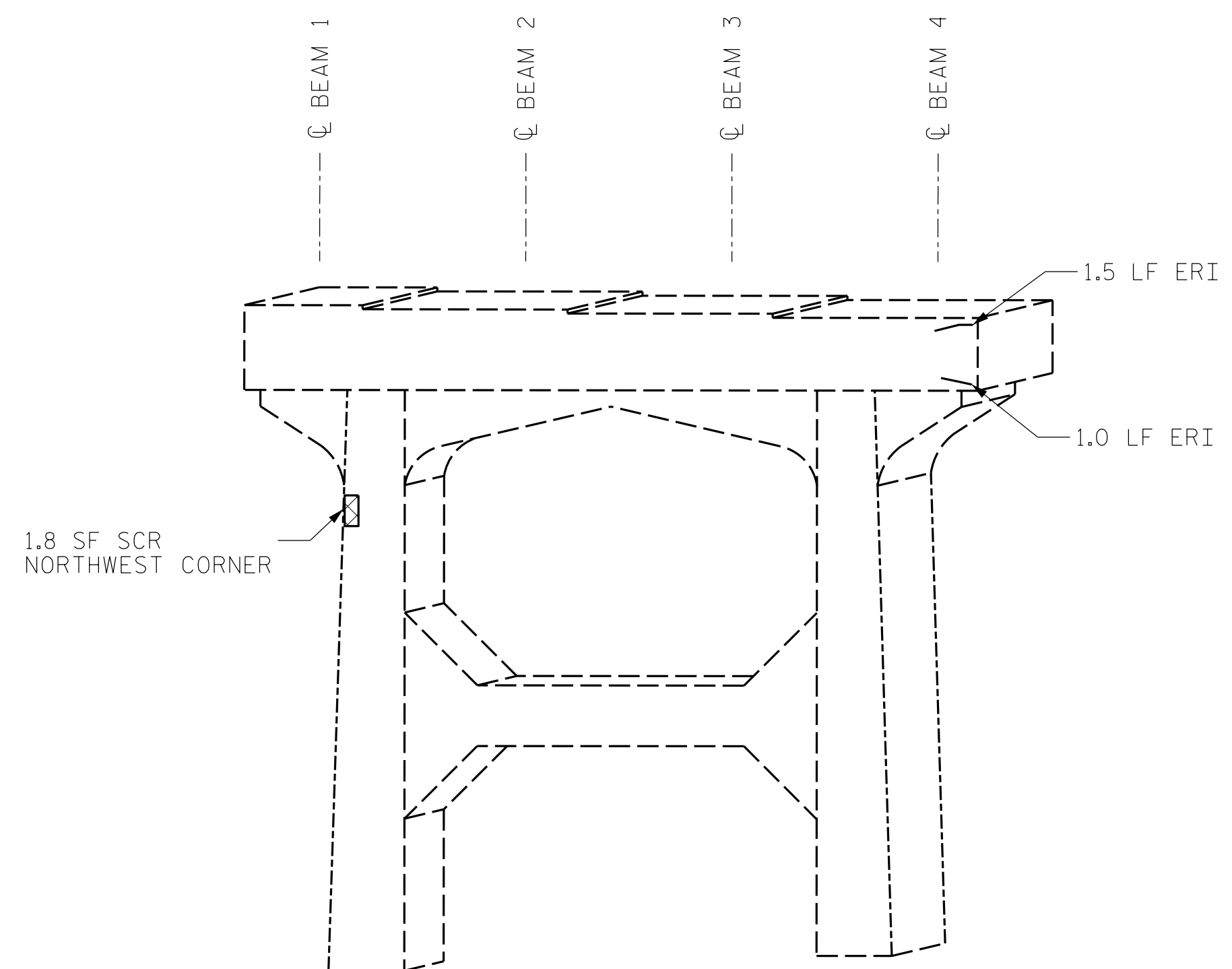

BENT 3  
(WEST FACE)

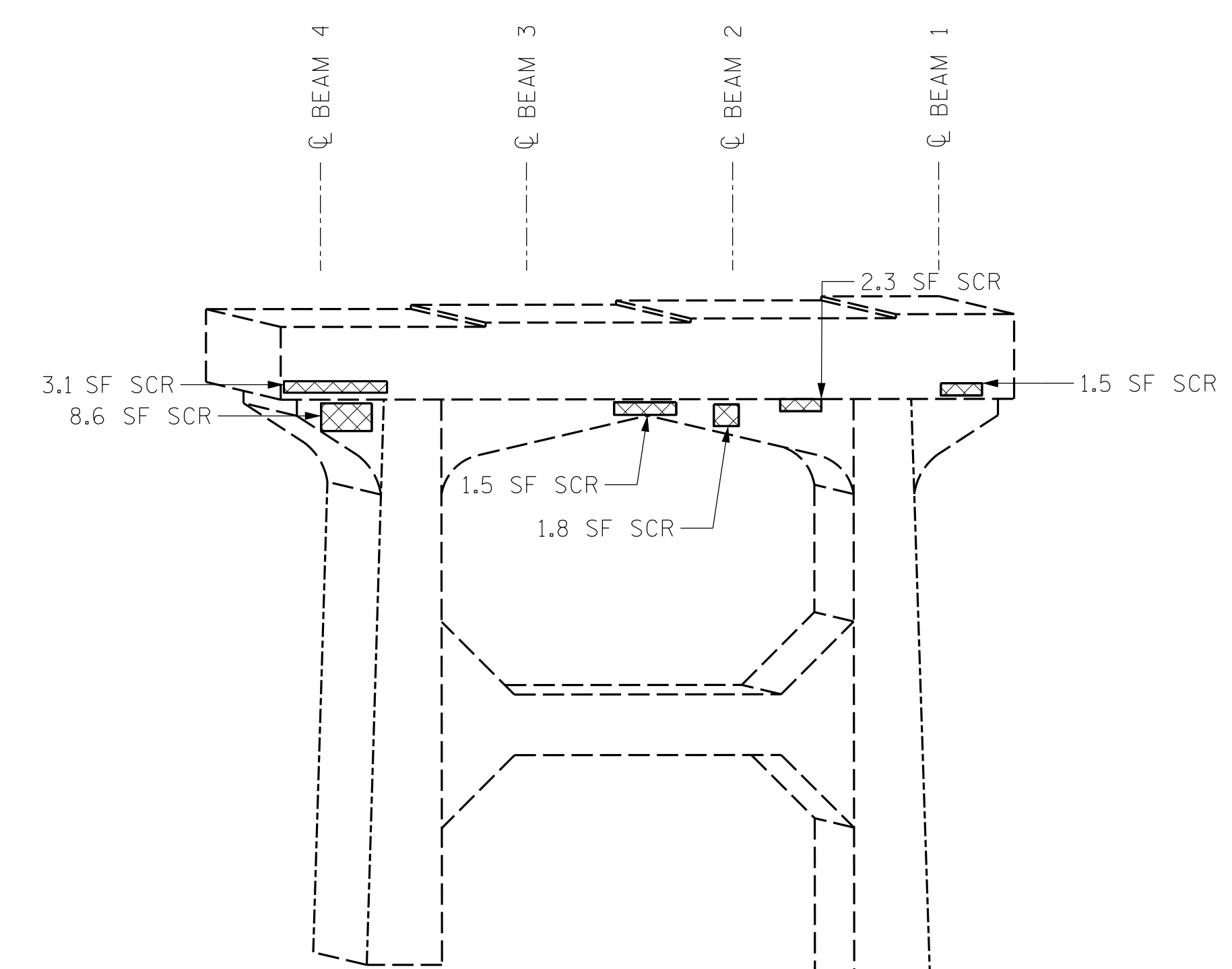

BENT 3  
(EAST FACE)

LEGEND	
	CONCRETE REPAIR AREA (CR)
	SHOTCRETE REPAIR AREA (SCR)
	EPOXY RESIN INJECTION (ERI)

	AS-BUILT REPAIR QUANTITY TABLE			
	ESTIMATE		ACTUAL	
SHOTCRETE REPAIRS	AREA SQ. FT.	VOLUME CU. FT.	AREA SQ. FT.	VOLUME CU. FT.
CAP/BACKWALL	18.8	6.4		
COLUMN/PILE	1.8	0.6		
CONCRETE REPAIRS	AREA SQ. FT.	VOLUME CU. FT.	AREA SQ. FT.	VOLUME CU. FT.
CAP	-	-		
EPOXY RESIN INJECTION	LIN. FT.		LIN. FT.	
CAP/BACKWALL	2.5			
COLUMN/PILE	-			

VALUES IN CHART REPRESENT ESTIMATED REPAIR TOTALS AFTER REMOVAL OF UNSOUND CONCRETE. MINIMUM OF 1" BEHIND REBAR AND MINIMUM 2" CLEARANCE TO SAWCUT. FOR REPAIR DETAILS, SEE "CONCRETE RESTORATION DETAILS" SHEETS.

**NOTES:**

REPAIR LOCATIONS AND ESTIMATED QUANTITIES ARE GIVEN WITH THE BEST INFORMATION AVAILABLE. IF ADDITIONAL REPAIRS NOT SHOWN ON THE DRAWINGS ARE DEEMED NECESSARY BY THE ENGINEER, THE ENGINEER WILL NOTE ON THE DRAWINGS THE APPROXIMATE LOCATIONS AND DESCRIPTION OF THE REPAIRS AND ADJUST THE ACTUAL QUANTITIES ENTERED INTO THE TABLE ABOVE.

CRACKING LOCATIONS AND QUANTITIES FOR LOCATIONS DESCRIBED AS "SCATTERED THROUGHOUT" IN THE INSPECTION REPORT ARE BASED ON THE BEST INFORMATION AVAILABLE. THE ENGINEER AND CONTRACTOR SHALL IDENTIFY AND REPAIR ALL CRACKS  $\geq 1/16"$  AS DESCRIBED IN THE SPECIAL PROVISIONS AT EACH BENT.

AVERAGE CONCRETE COVER IS EXPECTED TO BE FROM 2" TO 3" ON THE CAP AND FROM 1 1/2" TO 2" ON THE PILES. ACTUAL CONCRETE COVER SHALL BE DETERMINED BY THE CONTRACTOR AND PRESENTED TO THE ENGINEER PRIOR TO BEGINNING EXCAVATION/ DEMOLITION.

FOR CONCRETE AND SHOTCRETE REPAIRS, SEE "CONCRETE RESTORATION DETAILS" SHEETS.

SHOTCRETE REPAIRS MAY BE REPLACED WITH CONCRETE REPAIRS WITH THE APPROVAL OF THE ENGINEER.

REPAIRS TO THE BENT CAP MAY REQUIRE BRIDGE JACKING. FOR BRIDGE JACKING, SEE SPECIAL PROVISIONS.

PROJECT NO. I-5915B  
CATAWBA COUNTY  
 BRIDGE NO. 170177

SHEET 4 OF 4

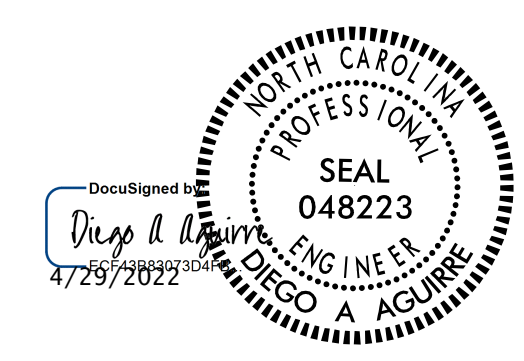

STATE OF NORTH CAROLINA  
 DEPARTMENT OF TRANSPORTATION  
 RALEIGH  
**SUBSTRUCTURE REPAIRS**  
 BENT 3

DRAWN BY : ALLEN J. MCSWAIN DATE : 01/2022  
 CHECKED BY : FIDEL L. FLORES DATE : 01/2022  
 DESIGN ENGINEER OF RECORD: DIEGO A. AGUIRRE DATE : 01/2022

4/21/2022  
 I5915B.SMU.SBR03.170177.dgn  
 daquirre

DOCUMENT NOT CONSIDERED  
 FINAL UNLESS ALL  
 SIGNATURES COMPLETED

REVISIONS						SHEET NO.
NO.	BY:	DATE:	NO.	BY:	DATE:	S3-11
1			3			TOTAL SHEETS
2			4			11

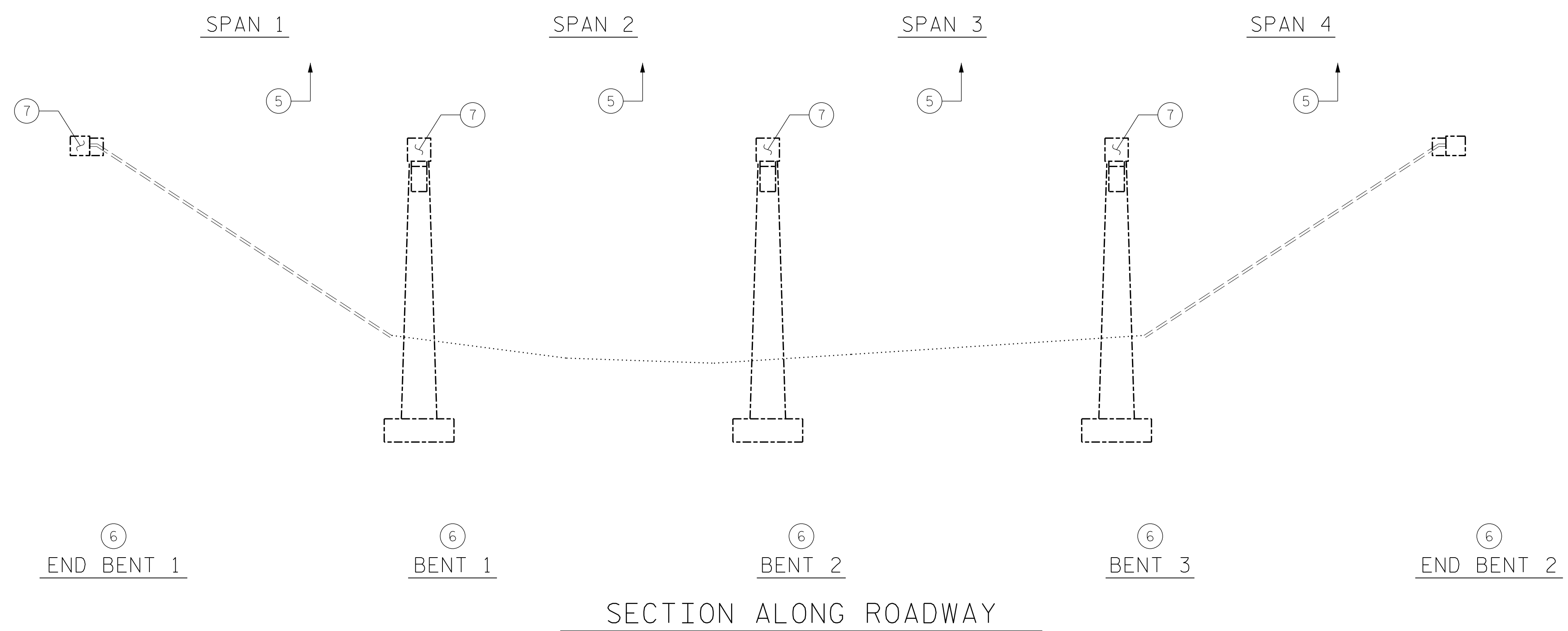

- SCOPE LEGEND:**
- ① CLEAR SHOULDERS OF DEBRIS AND VEGETATION
  - ② CONCRETE DECK REPAIRS
  - ③ ASPHALT JOINT REPAIR/REPLACEMENT (TYP.)
  - ④ ADD ASPHALT WEARING SURFACE
  - ⑤ REINFORCED CONCRETE GIRDER REPAIRS
  - ⑥ SUBSTRUCTURE CONCRETE REPAIRS
  - ⑦ SUBSTRUCTURE EPOXY RESIN INJECTION
  - ⑧ APPROACH ROADWAY MILLING AND RESURFACING
  - ⑨ CLEAN AND PAINT EXISTING BEARINGS WITH HRSCA

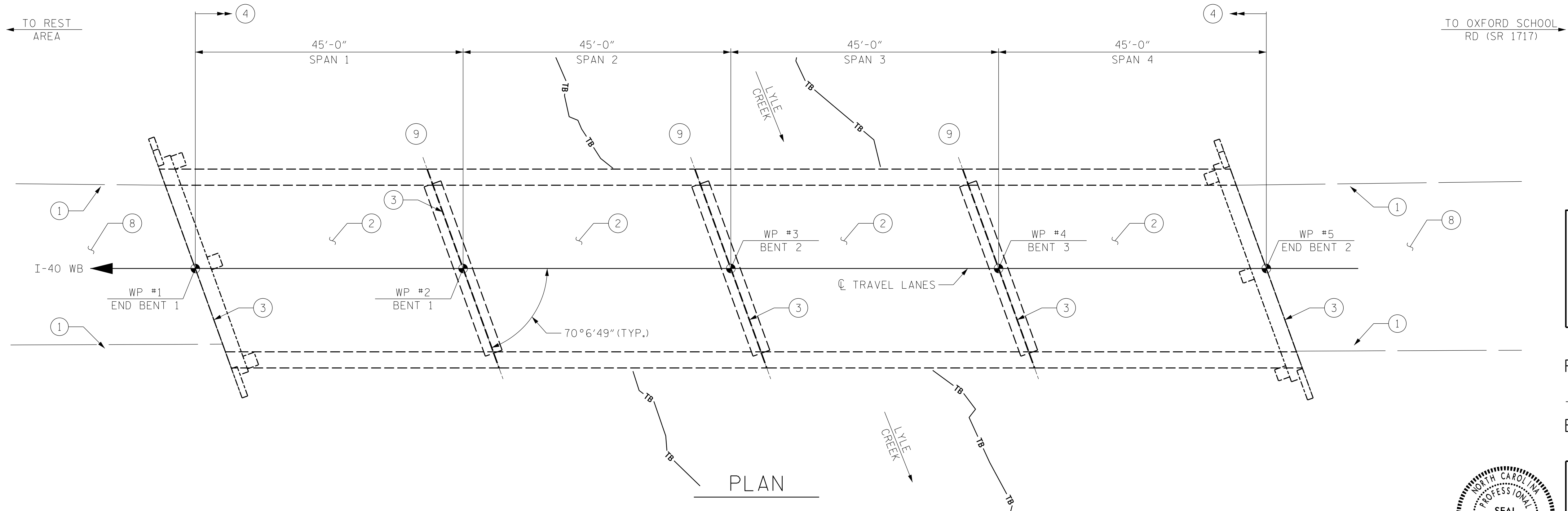

I HEREBY CERTIFY THAT THIS STRUCTURE WAS REHABILITATED ACCORDING TO THESE PLANS OR AS NOTED THEREIN.

RESIDENT ENGINEER \_\_\_\_\_ DATE \_\_\_\_\_

PROJECT NO. I-5915B  
CATAWBA COUNTY  
 BRIDGE NO. 170178

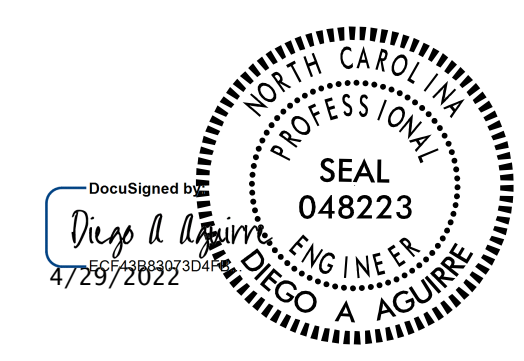

STATE OF NORTH CAROLINA  
 DEPARTMENT OF TRANSPORTATION  
 RALEIGH

**GENERAL DRAWING**

FOR BRIDGE ON I-40 WB  
 OVER LYLE CREEK

**NOTES:**

GENERAL DRAWING INFORMATION IS TAKEN FROM THE ORIGINAL PLANS AND THE MOST UP TO DATE ROUTINE INSPECTION REPORT DATED 03/21/2021.

DRAWN BY : DIEGO A. AGUIRRE DATE : 01/2022  
 CHECKED BY : FIDEL L. FLORES DATE : 01/2022  
 DESIGN ENGINEER OF RECORD: DIEGO A. AGUIRRE DATE : 01/2022

DOCUMENT NOT CONSIDERED FINAL UNLESS ALL SIGNATURES COMPLETED

**KCA**  
**KISINGER CAMPO & ASSOCIATES**  
 301 FAYETTEVILLE ST., SUITE 1500  
 RALEIGH, NC 27601 (919) 882-7839  
 NC FIRM LICENSE: C-1506

REVISIONS						SHEET NO.	
NO.	BY:	DATE:	NO.	BY:	DATE:	S4-1	
1			3			TOTAL SHEETS	11
2			4				



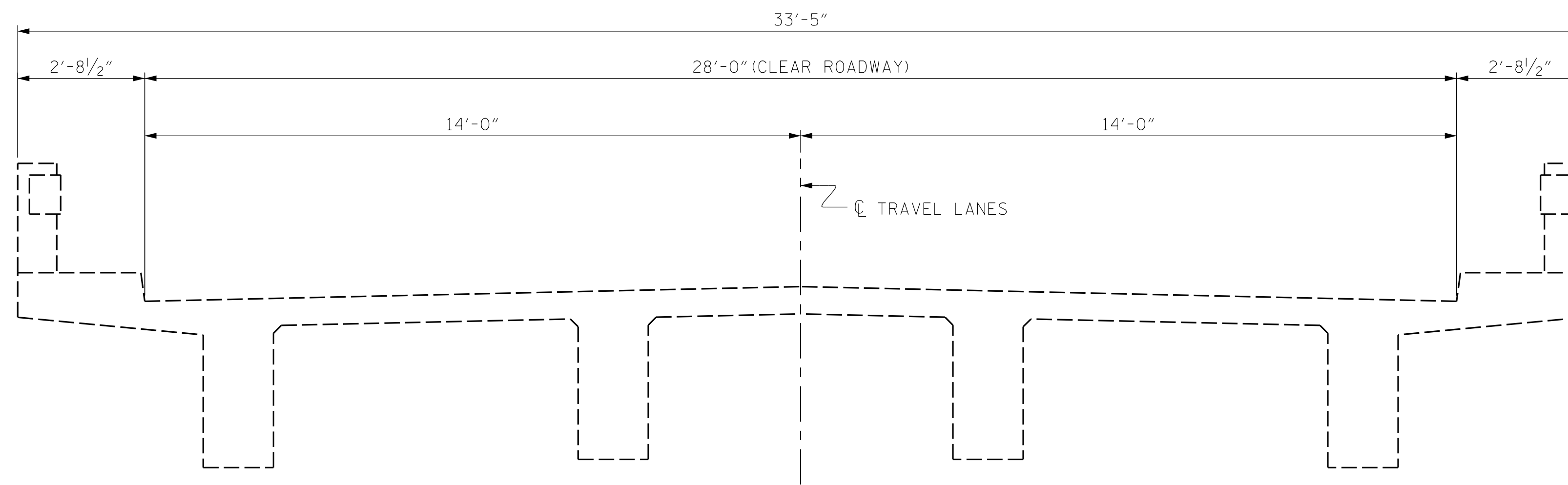

EXISTING

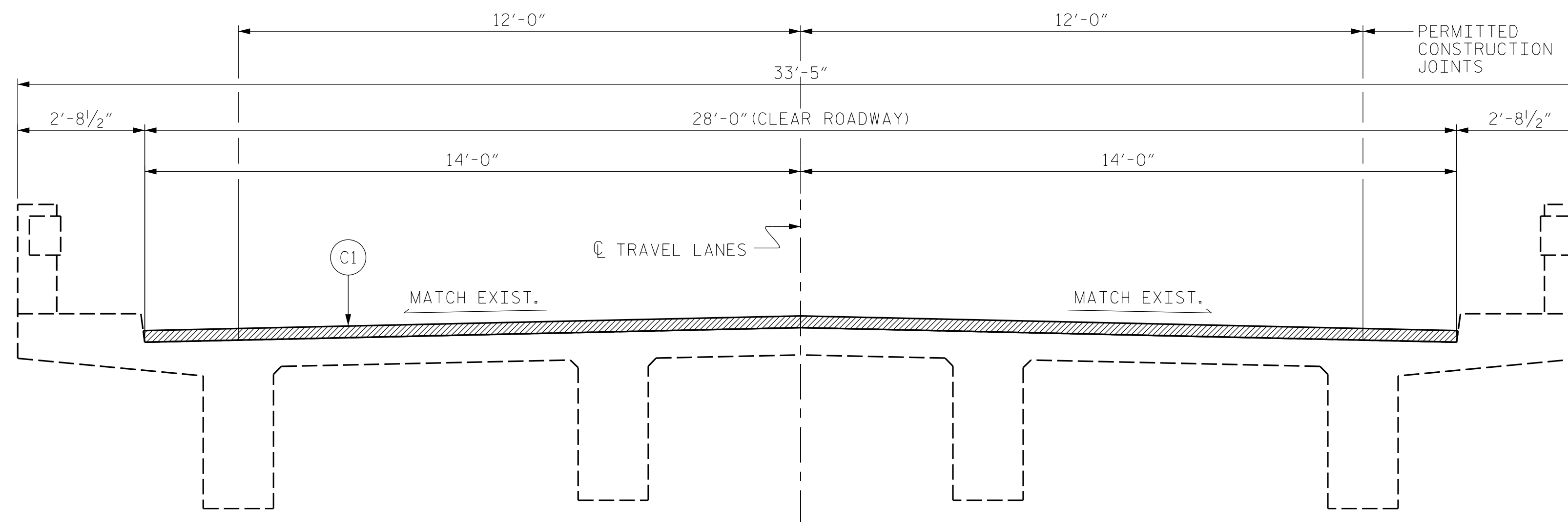

PROPOSED

**NOTES:**

LONGITUDINAL CONSTRUCTION JOINTS OF OVERLAYS SHALL BE LOCATED ALONG THE CENTERLINE OR EDGE OF TRAVEL LANES.

SEE TRAFFIC MANAGEMENT PLANS FOR LANE WIDTHS, SEQUENCING, AND OTHER TRAFFIC CONTROL MEASURES FOR STAGING OF ASPHALT WEARING SURFACE (AWS) OVERLAY.

FOR NEW ASPHALT PLACEMENT, SEE STANDARD SPECIFICATIONS.

C1	PROPOSED APPROXIMATE 2" MIN. ASPHALT CONCRETE SURFACE COURSE, TYPE S9.5C AT AN AVERAGE RATE OF 112 LBS. PER SQ. YD. PER 1" DEPTH. TO BE PLACED IN LAYERS NOT LESS THAN 1" OR GREATER THAN 2" IN DEPTH.
----	--

ASPHALT CONCRETE SURFACE COURSE, TYPE S9.5C



**KCS**  
KISINGER CAMPO  
& ASSOCIATES  
301 FAYETTEVILLE ST., SUITE 1500  
RALEIGH, NC 27601 (919) 882-7839  
NC FIRM LICENSE: C-1506

PROJECT NO. I-5915B  
CATAWBA COUNTY  
BRIDGE NO. 170178

STATE OF NORTH CAROLINA  
DEPARTMENT OF TRANSPORTATION  
RALEIGH

TYPICAL SECTION

DRAWN BY :	DIEGO A. AGUIRRE	DATE :	01/2022
CHECKED BY :	FIDEL L. FLORES	DATE :	01/2022
DESIGN ENGINEER OF RECORD:	DIEGO A. AGUIRRE	DATE :	01/2022

4/21/2022  
I5915B.SMU.TS01.170178.dgn  
daquirre

DOCUMENT NOT CONSIDERED  
FINAL UNLESS ALL  
SIGNATURES COMPLETED

REVISIONS						SHEET NO.
NO.	BY:	DATE:	NO.	BY:	DATE:	
1			3			S4-2
2			4			TOTAL SHEETS 11

# AS-BUILT REPAIR QUANTITY TABLE

## DECK REPAIRS

	SPAN 1		SPAN 2		SPAN 3		SPAN 4	
	ESTIMATE	ACTUAL	ESTIMATE	ACTUAL	ESTIMATE	ACTUAL	ESTIMATE	ACTUAL
CLASS II SURFACE PREPARATION	13.3 SY		1.6 SY		-- SY		45.7 SY	
CLASS III SURFACE PREPARATION	-- SY		-- SY		-- SY		0.6 SY	
	AREA	VOLUME	AREA	VOLUME	AREA	VOLUME	AREA	VOLUME
SHOTCRETE REPAIR AREA (SCR)	-- SF	-- CF			-- SF	-- CF		
							4.9 SF	1.7 CF

### LEGEND:

SCR SHOTCRETE REPAIR

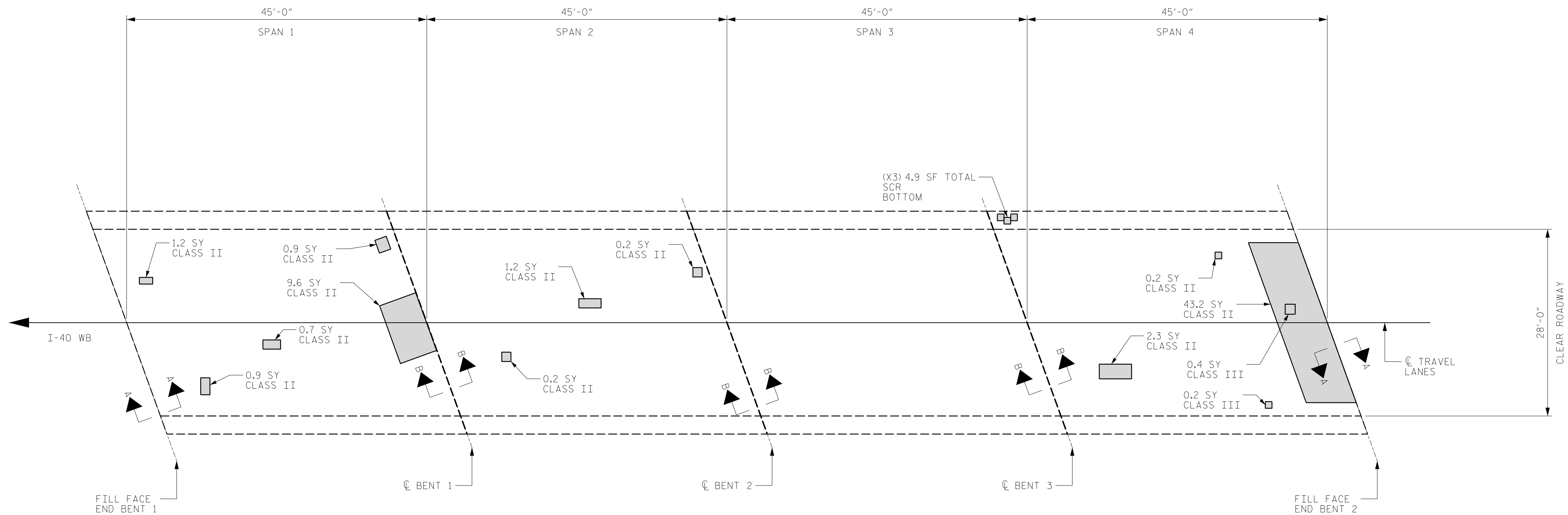
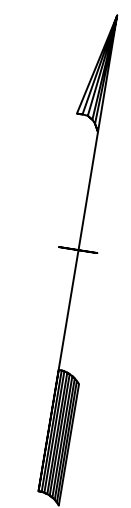

PLAN

### NOTES:

PRIOR TO SURFACE PREPARATION, REMOVE ALL LOOSE, DISINTEGRATED, UNSOUND OR CONTAMINATED CONCRETE FROM THE BRIDGE DECK.

FOR CONCRETE FOR DECK REPAIR, SEE SPECIAL PROVISIONS.

FOR SCARIFYING BRIDGE DECK, SEE OVERLAY SURFACE PREPARATION SPECIAL PROVISION.

REPAIR LOCATIONS AND ESTIMATED QUANTITIES ARE GIVEN WITH THE BEST INFORMATION AVAILABLE. IF ADDITIONAL REPAIRS NOT SHOWN ON THE DRAWINGS ARE DEEMED NECESSARY BY THE ENGINEER, THE ENGINEER WILL NOTE ON THE DRAWINGS THE APPROXIMATE LOCATIONS AND DESCRIPTION OF THE REPAIRS AND ADJUST THE ACTUAL QUANTITIES ENTERED INTO THE AS-BUILT REPAIR QUANTITY TABLE.

DEFECTS (SEE PLAN CALLOUT FOR DETAILS)

DRAWN BY : ALLEN J. MCSWAIN DATE : 01/2022  
 CHECKED BY : JACOB H. DUKE DATE : 01/2022  
 DESIGN ENGINEER OF RECORD: DIEGO A. AGUIRRE DATE : 01/2022

4/21/2022  
 I5915B.SMU.DSR01.170178.dgn  
 daquirre

PROJECT NO. I-5915B  
 CATAWBA COUNTY  
 BRIDGE NO. 170178

SHEET 1 OF 2

STATE OF NORTH CAROLINA  
 DEPARTMENT OF TRANSPORTATION  
 RALEIGH

## PLAN OF SPANS DECK REPAIRS



**KISINGER CAMPO & ASSOCIATES**  
 301 FAYETTEVILLE ST., SUITE 1500  
 RALEIGH, NC 27601 (919) 882-7839  
 NC FIRM LICENSE: C-1506

DOCUMENT NOT CONSIDERED  
 FINAL UNLESS ALL  
 SIGNATURES COMPLETED

REVISIONS						SHEET NO.
NO.	BY:	DATE:	NO.	BY:	DATE:	
1			3			S4-3
2			4			TOTAL SHEETS 11



### AS-BUILT REPAIR QUANTITY TABLE

	SPAN 1		SPAN 2		SPAN 3		SPAN 4	
	ESTIMATE	ACTUAL	ESTIMATE	ACTUAL	ESTIMATE	ACTUAL	ESTIMATE	ACTUAL
ASPHALT CONCRETE SURFACE COURSE, TYPE S9.5C	16 TON		16 TON		16 TON		16 TON	
ASPHALT BINDER FOR PLANT MIX	1.0 TON		1.0 TON		1.0 TON		1.0 TON	

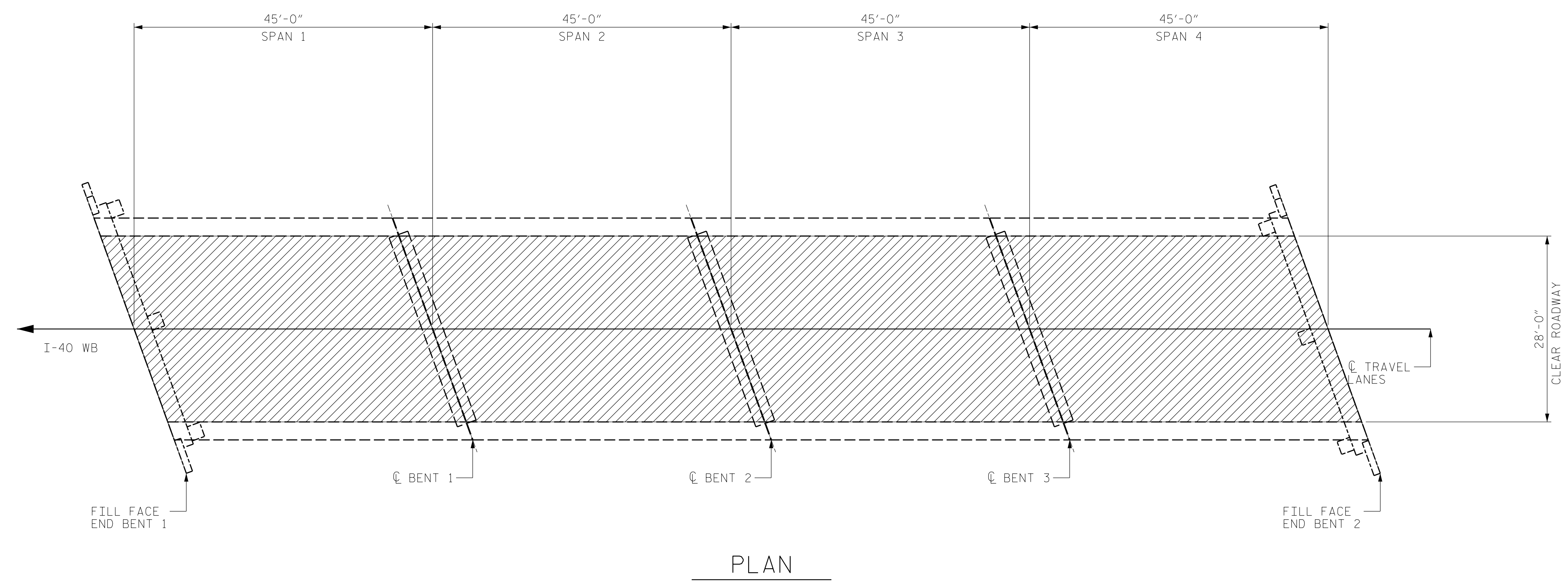

**NOTES:**

- WORK THIS SHEET WITH "JOINT DETAILS" SHEET.
- WORK THIS SHEET WITH "TYPICAL SECTION" SHEET.
- WORK THIS SHEET WITH "DECK REPAIR DETAILS" SHEET.
- FOR NEW ASPHALT PLACEMENT, SEE STANDARD SPECIFICATIONS.

 ASPHALT CONCRETE SURFACE COURSE, TYPE S9.5C

DRAWN BY : FIDEL L. FLORES DATE : 01/2022  
 CHECKED BY : JACOB H. DUKE DATE : 01/2022  
 DESIGN ENGINEER OF RECORD: DIEGO A. AGUIRRE DATE : 01/2022

4/21/2022  
 I5915B.SMU.DSR02.170178.dgn  
 daguirre

DOCUMENT NOT CONSIDERED  
 FINAL UNLESS ALL  
 SIGNATURES COMPLETED

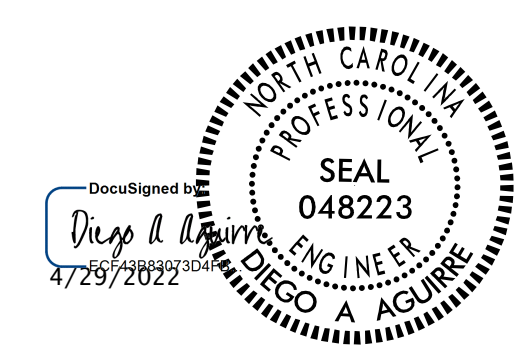

**KCA**  
**KISINGER CAMPO & ASSOCIATES**  
 301 FAYETTEVILLE ST., SUITE 1500  
 RALEIGH, NC 27601 (919) 882-7839  
 NC FIRM LICENSE: C-1506

PROJECT NO. I-5915B  
CATAWBA COUNTY  
 BRIDGE NO. 170178

SHEET 2 OF 2

STATE OF NORTH CAROLINA DEPARTMENT OF TRANSPORTATION RALEIGH					
PLAN OF SPANS ASPHALT WEARING SURFACE					
REVISIONS					
NO.	BY:	DATE:	NO.	BY:	DATE:
1			3		
2			4		
SHEET NO.					S4-4
TOTAL SHEETS					11

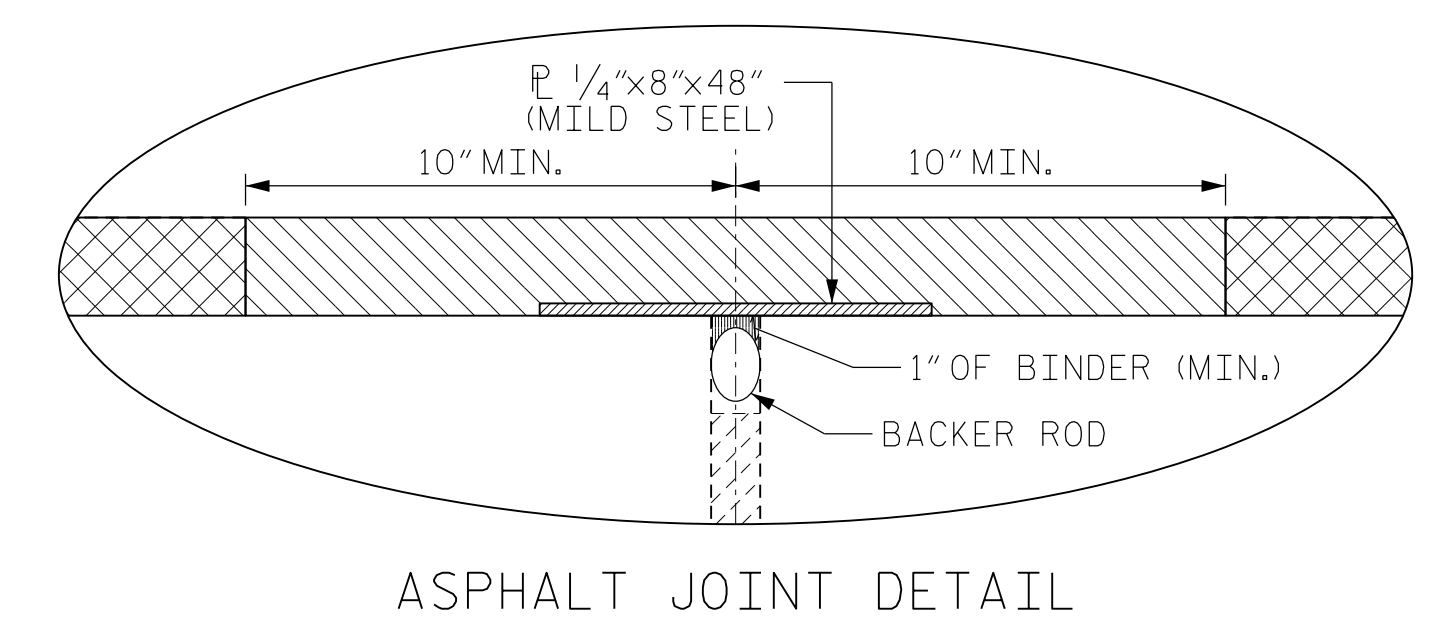
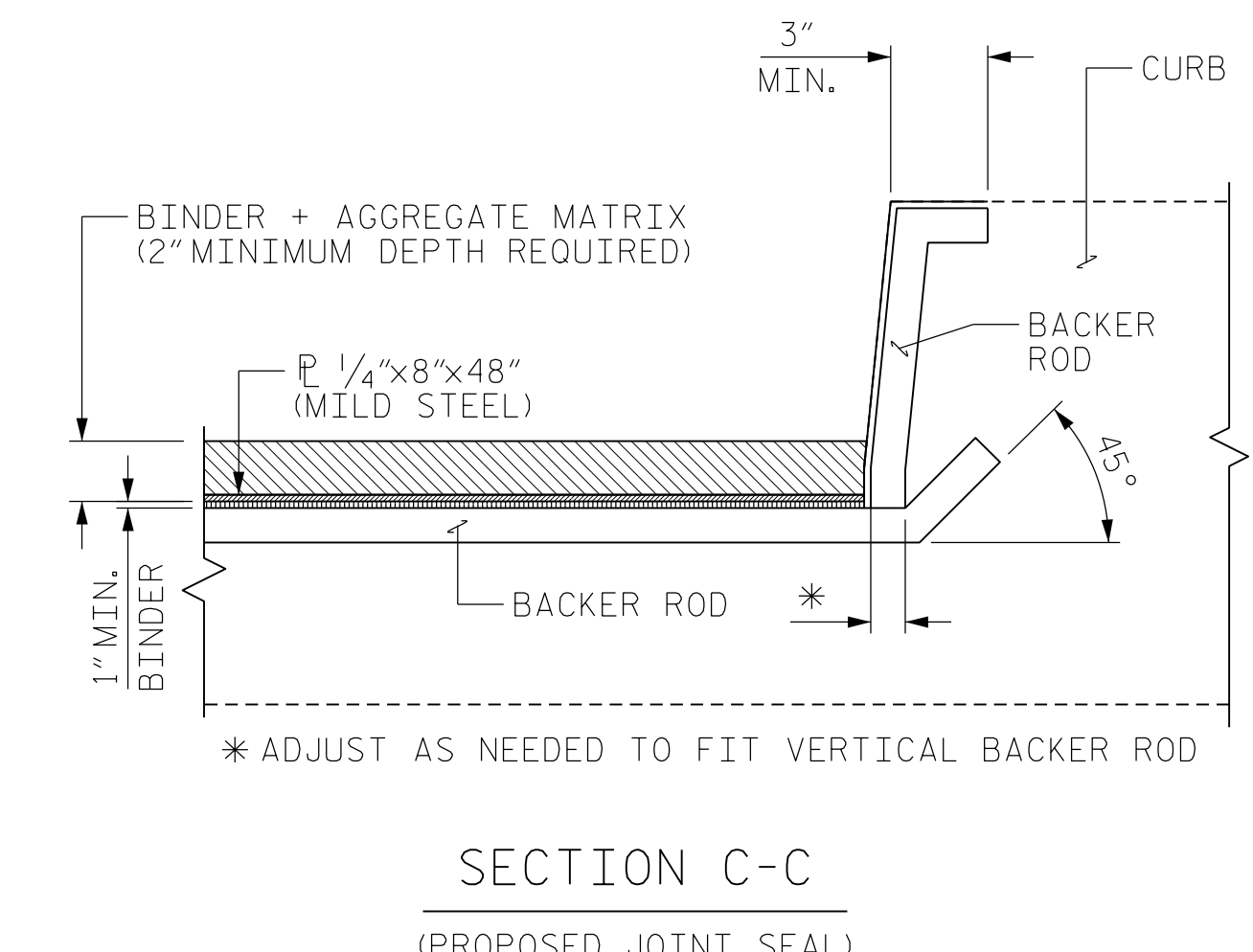
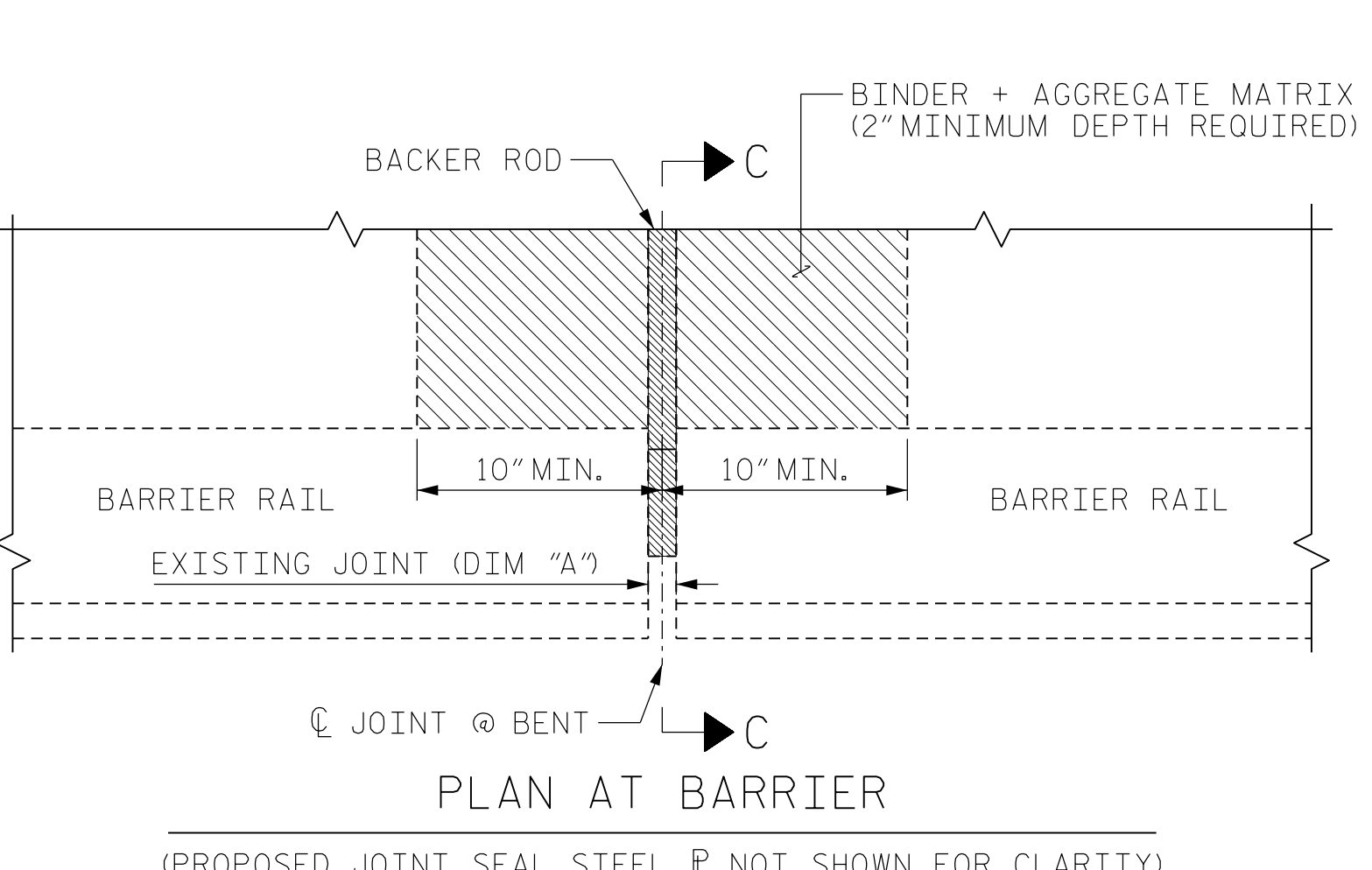
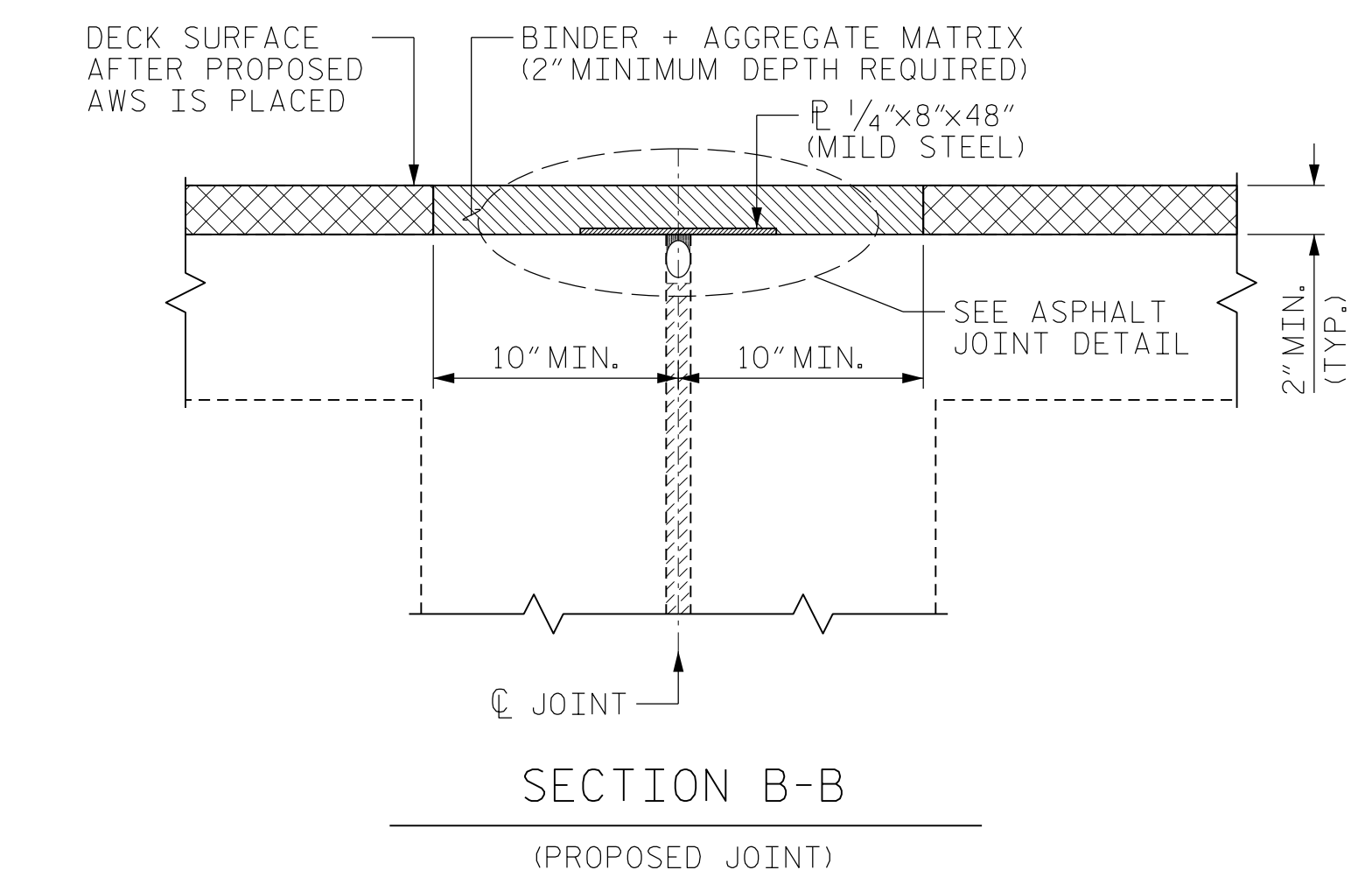
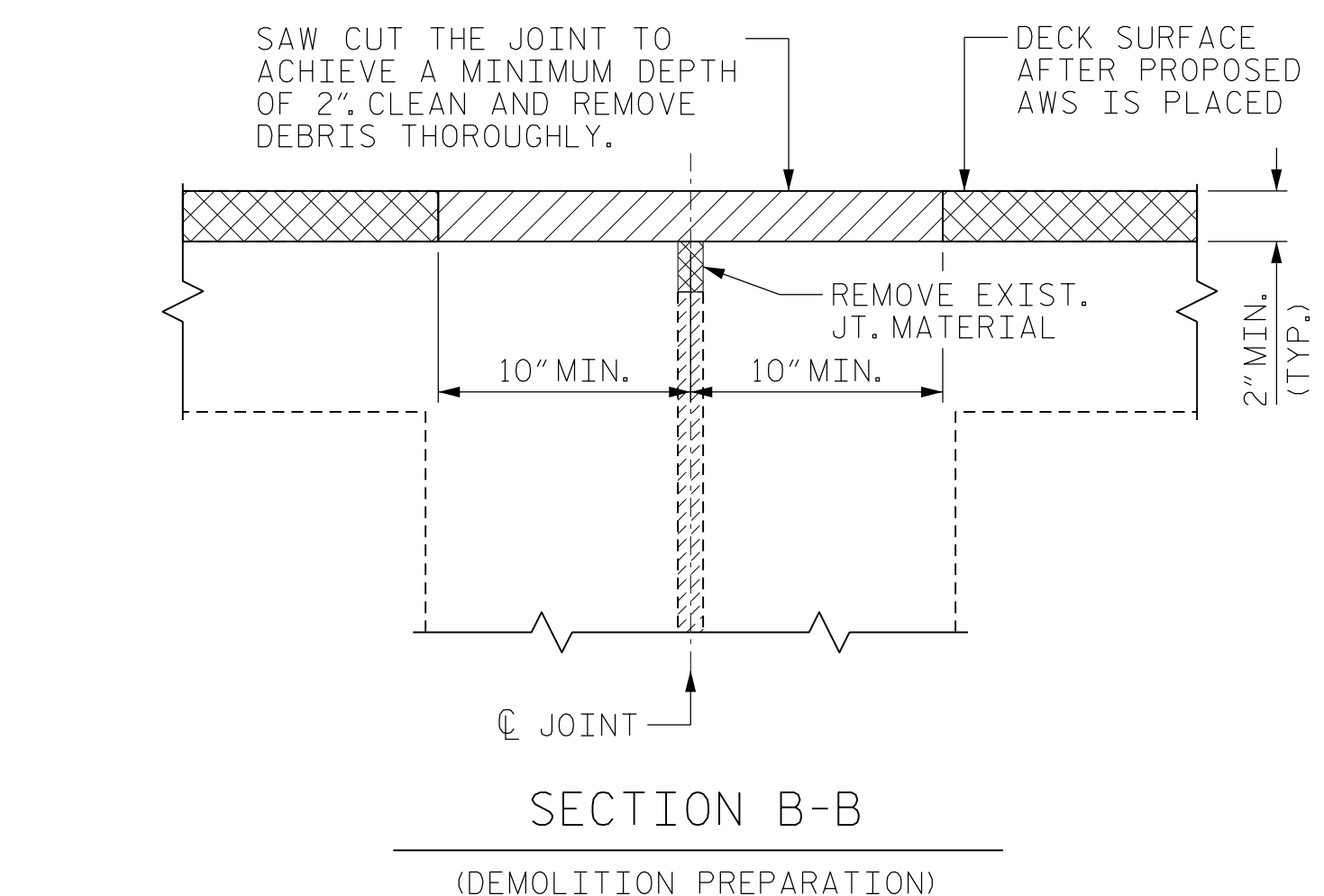
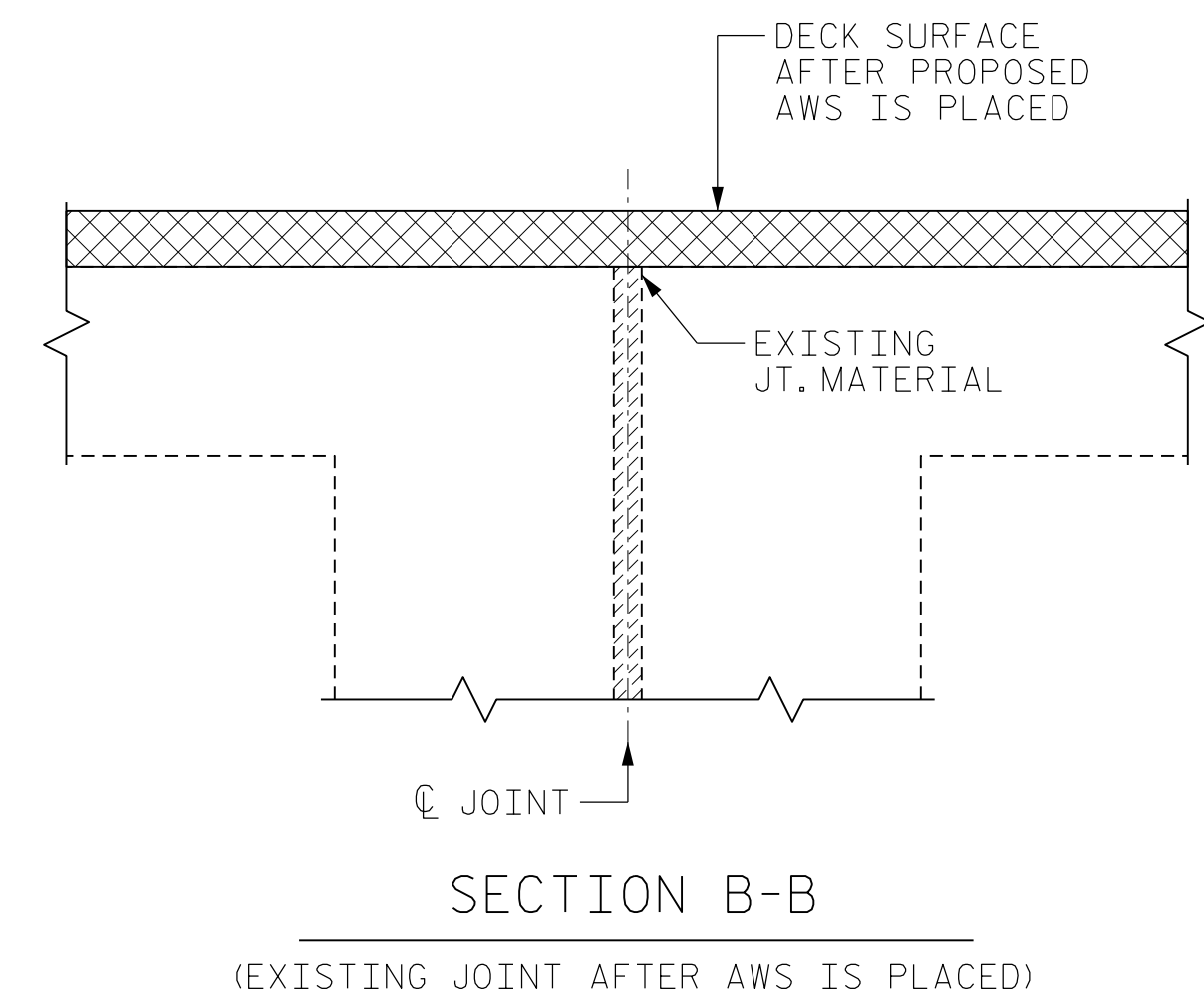
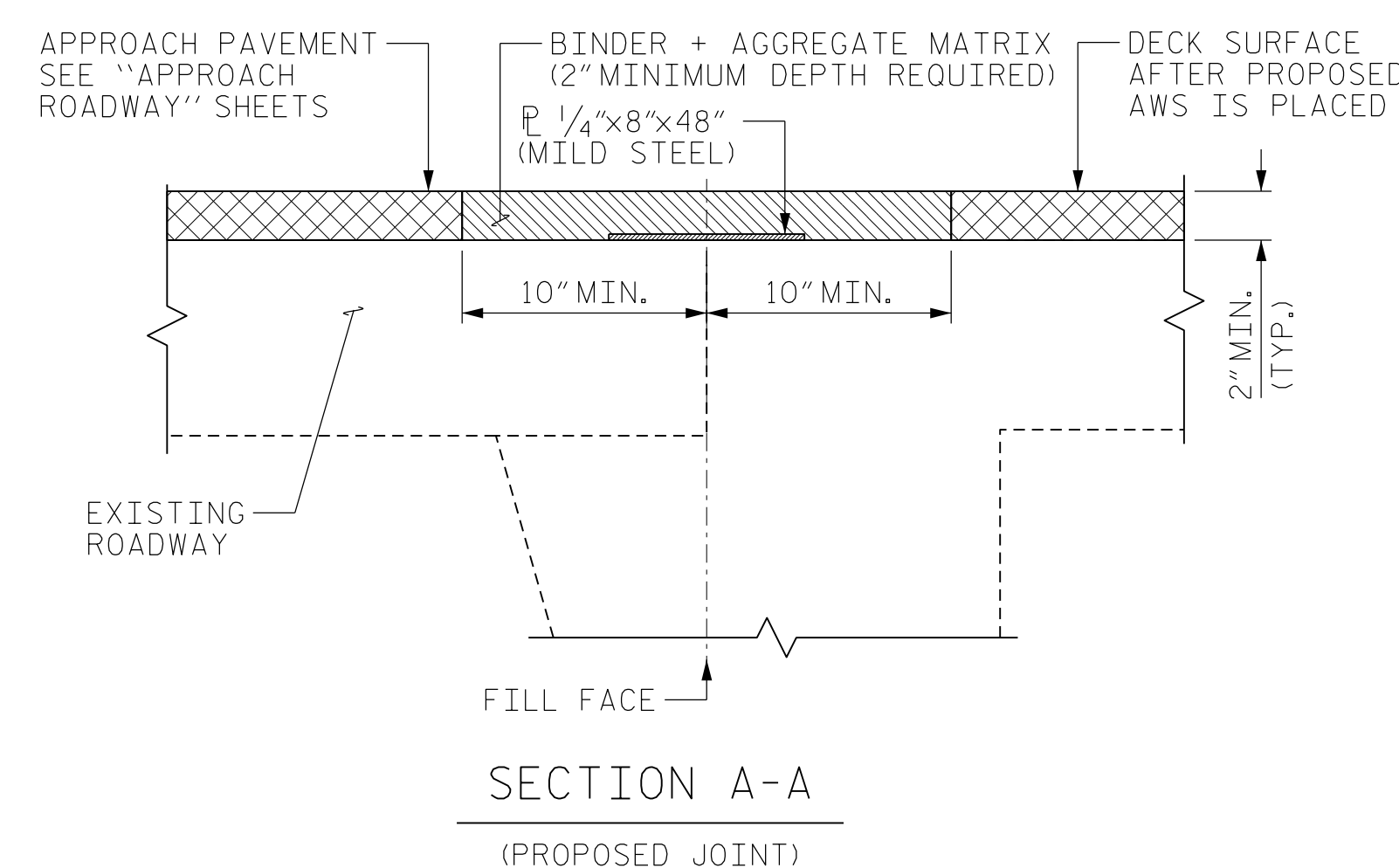
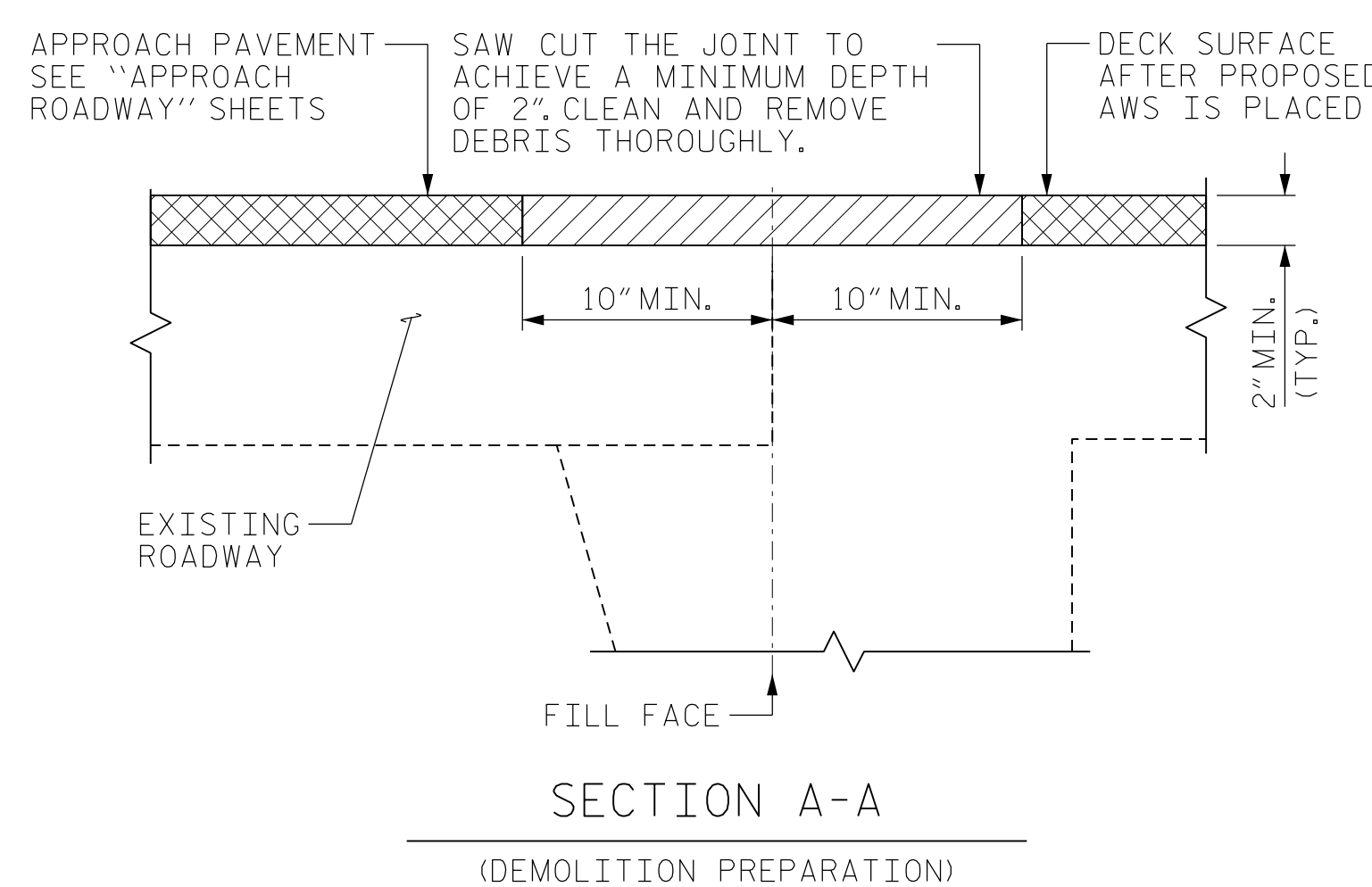
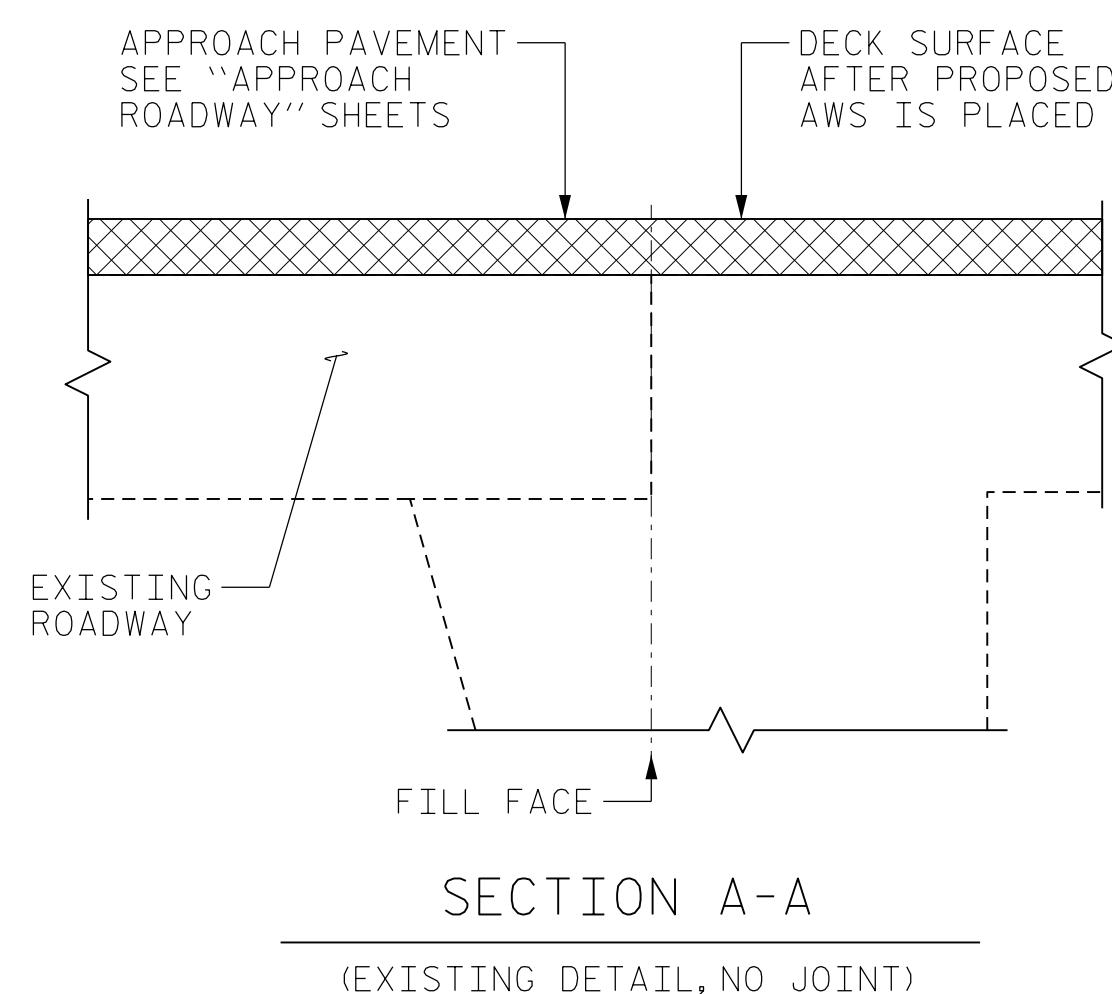

NOTES:

- THE CONTRACTOR SHALL FIELD VERIFY THE EXISTING JOINT OPENING PRIOR TO ORDERING JOINT SEAL MATERIAL. IF THE ACTUAL OPENING VARIES FROM THE OPENING INDICATED IN THE DETAIL BY MORE THAN 1/4", NOTIFY THE ENGINEER. REVISION OF THE JOINT SEAL SIZE MIGHT BE NECESSARY.
- THE CONTRACTOR SHALL TAKE CARE DURING JOINT REPAIR OPERATIONS NOT TO DROP ANY MATERIAL THAT FALLS BELOW THE BRIDGE, WITHOUT PROTECTIVE DEVICES BELOW TO CATCH THE MATERIAL. ANY MATERIAL THAT FALLS BELOW THE BRIDGE SHALL BE CONTAINED, REMOVED AND DISPOSED OF BY THE CONTRACTOR AT NO EXTRA COST TO THE DEPARTMENT. IF THE ENGINEER DETERMINES THAT THE PROTECTIVE DEVICES ARE NOT ADEQUATE OR NOT BEING EMPLOYED, THE WORK SHALL BE SUSPENDED UNTIL ADEQUATE PROTECTION IS PROVIDED.
- THE CONTRACTOR WILL NOT BE PERMITTED TO FORM THE JOINTS IN LIEU OF SAWING THE JOINT.
- THE INSTALLED BACKER ROD AND SILICONE SEALANT SHALL BE WATER TIGHT.
- FOR EXCAVATION BELOW THE BOTTOM OF THE PLANNED JOINT DECK DEMOLITION, CONCRETE FOR DECK REPAIRS SHALL BE PLACED IN THE EXCAVATED AREA TO THE ELEVATION AT BOTTOM OF THE PROPOSED ASPHALT JOINT DETAIL SHOWN.
- DEMOLISH BRIDGE JOINT AREA SUCH THAT THE BOTTOM OF THE EXCAVATION SHALL BE REASONABLY FLAT AND LEVEL AND TO THE NECESSARY DEPTH, SUCH THAT ASPHALT JOINT SHALL BE FOUNDED ON CONCRETE OR REPAIR CONCRETE SUBSTRATE.
- PRIOR TO ASPHALT JOINT REPAIR/REPLACEMENT, PERFORM DECK SURFACE REPAIRS IN ACCORDANCE WITH "PLAN OF SPAN" SHEETS.
- BACKER ROD SHALL BE INSTALLED AS PER MANUFACTURER'S RECOMMENDATIONS.
- FOR ASPHALT JOINT REPAIR/REPLACEMENT, SEE SPECIAL PROVISIONS.
- FOR CONCRETE FOR DECK REPAIR, SEE SPECIAL PROVISIONS.

PROPOSED JOINT QUANTITY		
	ESTIMATED (LIN.FT.)	ACTUAL (LIN.FT.)
ASPHALT JOINT REPAIR/REPLACEMENT	156.4	

PROJECT NO. I-5915B  
CATAWBA COUNTY  
 BRIDGE NO. 170178

BENT/ JOINTS	DIM "A" @ 60° F
END BENT 1	1 1/2"
1	1"
2	1"
3	1"
END BENT 2	1 1/2"

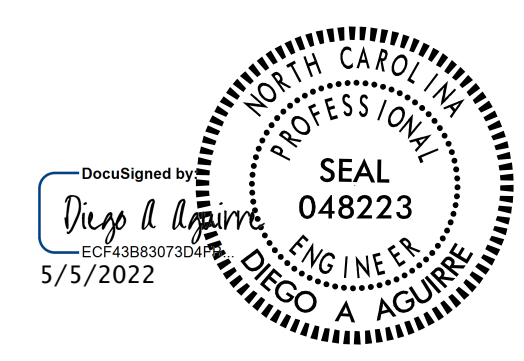

STATE OF NORTH CAROLINA DEPARTMENT OF TRANSPORTATION RALEIGH					
JOINT DETAILS					
REVISIONS					SHEET NO.
NO.	BY:	DATE:	NO.	BY:	DATE:
1			3		
2			4		
					S4-5
					TOTAL SHEETS 11

DRAWN BY : DIEGO A. AGUIRRE DATE : 01/2022  
 CHECKED BY : JACOB H. DUKE DATE : 01/2022  
 DESIGN ENGINEER OF RECORD: DIEGO A. AGUIRRE DATE : 01/2022

DOCUMENT NOT CONSIDERED FINAL UNLESS ALL SIGNATURES COMPLETED

301 FAYETTEVILLE ST., SUITE 1500  
 RALEIGH, NC 27601 (919) 882-7839  
 NC FIRM LICENSE: C-1506



# AS-BUILT REPAIR QUANTITY TABLE

	ESTIMATE	ACTUAL
INCIDENTAL MILLING	1377 SY	
ASPHALT CONCRETE SURFACE COURSE, TYPE S9.5C	193 TON	
ASPHALT BINDER FOR PLANT MIX	11.6 TON	

## NOTES:

INCIDENTAL MILLING - EXISTING APPROACH ASPHALT PAVEMENT TO BE MILLED AS NECESSARY TO ATTAIN MINIMUM 1/2" DEPTH OF NEW ASPHALT PAVEMENT. NEW ASPHALT PAVEMENT SHALL BE OF THICKNESS NECESSARY TO PROVIDE A SMOOTH TRANSITION BETWEEN THE ROADWAY AND THE BRIDGE DECK. THE NEW ASPHALT PAVEMENT THICKNESS MAY EXCEED 1/2" DUE TO SETTLEMENT OF THE EXISTING APPROACH.

FOR NEW ASPHALT PLACEMENT, SEE STANDARD SPECIFICATIONS.

GRADE MAY BE ADJUSTED BY THE ENGINEER TO ENSURE PROPER TIE-IN AT THE END BENTS.

**C1** PROPOSED VARIABLE DEPTH ASPHALT CONCRETE SURFACE COURSE, TYPE S9.5C AT AN AVERAGE RATE OF 112 LBS. PER SQ. YD. PER 1" DEPTH. TO BE PLACED IN LAYERS NOT LESS THAN 1" OR GREATER THAN 2" IN DEPTH.

INCIDENTAL MILLING

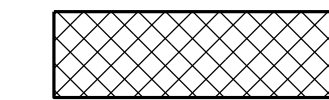

ASPHALT CONCRETE SURFACE COURSE, TYPE S9.5C (C1)

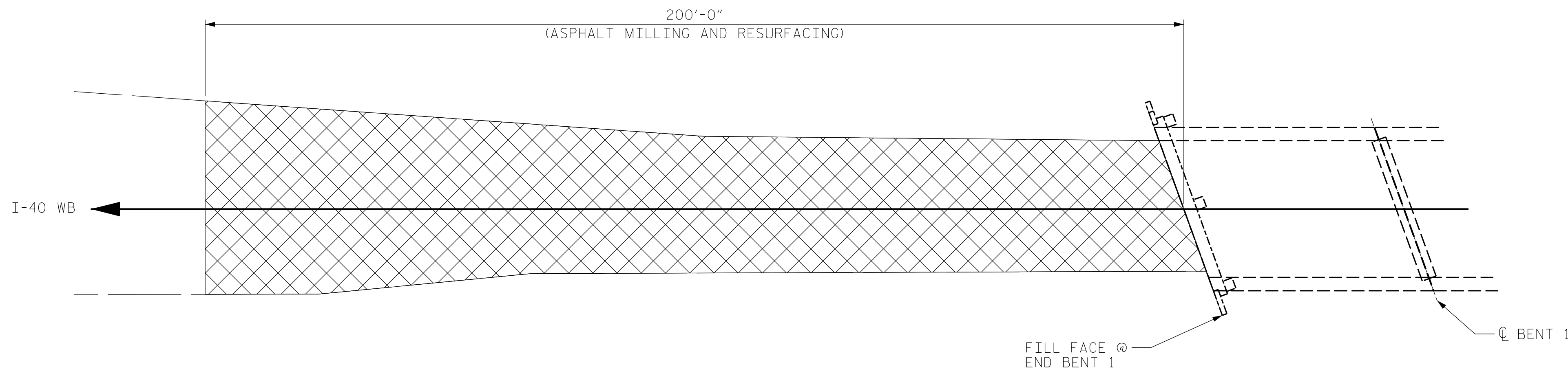

### BEGIN APPROACH SLAB

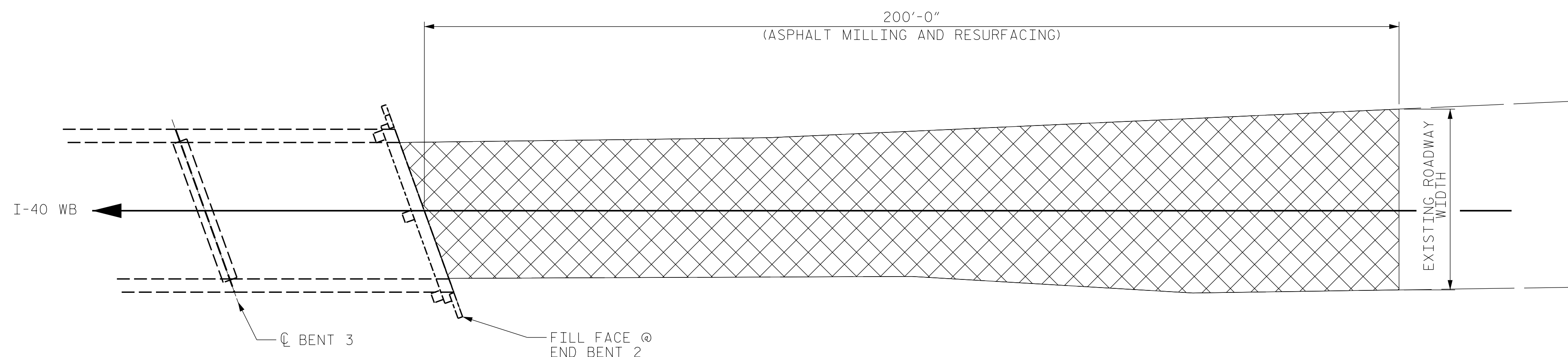

### END APPROACH SLAB

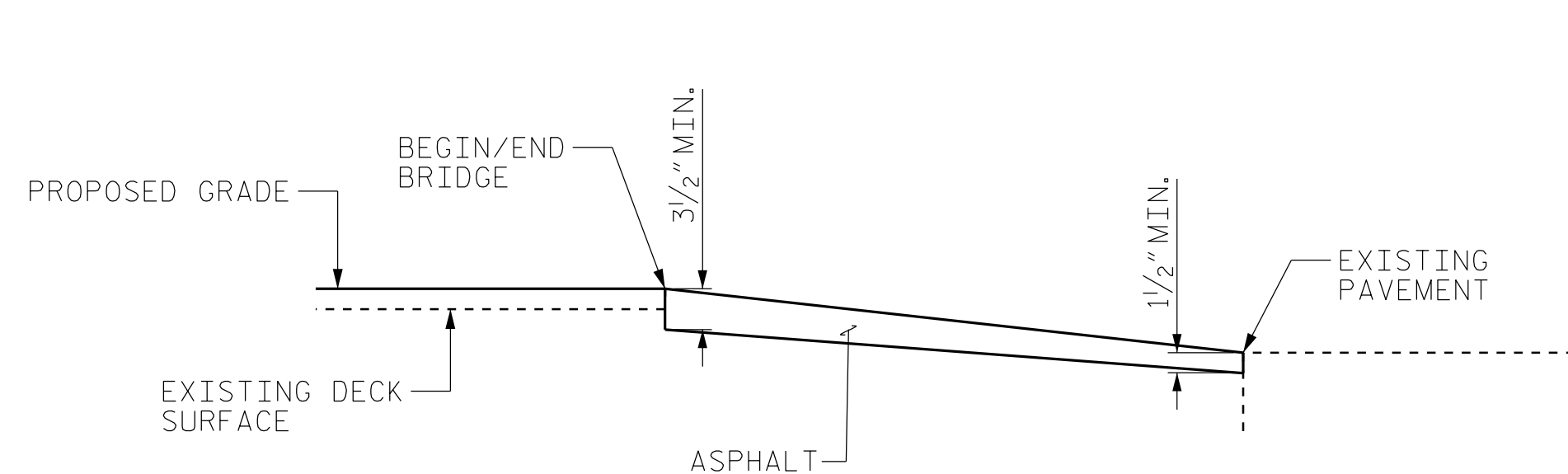

### PAVEMENT KEY-IN DETAIL FOR BOTH END BENTS

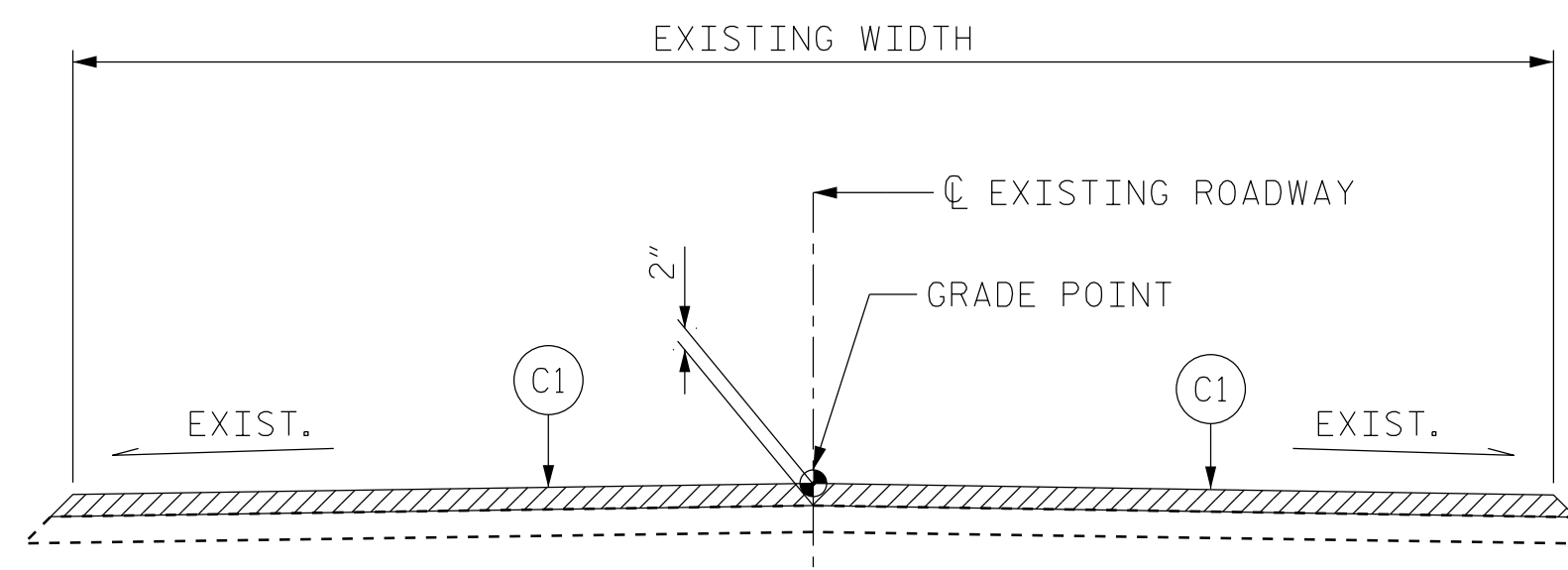

### ROADWAY SECTION

BEGIN/END BRIDGE

PROJECT NO. I-5915B  
CATAWBA COUNTY  
 BRIDGE NO. 170178



**KISINGER CAMPO & ASSOCIATES**  
 301 FAYETTEVILLE ST., SUITE 1500  
 RALEIGH, NC 27601 (919) 882-7839  
 NC FIRM LICENSE: C-1506

STATE OF NORTH CAROLINA  
 DEPARTMENT OF TRANSPORTATION  
 RALEIGH  
**APPROACH ROADWAY  
 MILLING AND RESURFACING**

DRAWN BY : FIDEL L. FLORES DATE : 01/2022  
 CHECKED BY : JACOB H. DUKE DATE : 01/2022  
 DESIGN ENGINEER OF RECORD: DIEGO A. AGUIRRE DATE : 01/2022

4/21/2022  
 I5915B\_SMU\_AR01.170178.dgn  
 daquirre

DOCUMENT NOT CONSIDERED  
 FINAL UNLESS ALL  
 SIGNATURES COMPLETED

REVISIONS						SHEET NO.
NO.	BY:	DATE:	NO.	BY:	DATE:	S4-6
1			3			TOTAL SHEETS
2			4			11

# AS-BUILT REPAIR QUANTITY TABLE

## SUPERSTRUCTURE REPAIRS

	SPAN 1				SPAN 2				SPAN 3				SPAN 4			
	ESTIMATE		ACTUAL		ESTIMATE		ACTUAL		ESTIMATE		ACTUAL		ESTIMATE		ACTUAL	
	AREA	VOLUME	AREA	VOLUME	AREA	VOLUME	AREA	VOLUME	AREA	VOLUME	AREA	VOLUME	AREA	VOLUME	AREA	VOLUME
CONCRETE REPAIR AREA (CR)	2.6 SF	0.9 CF			-- SF	-- CF			10.2 SF	3.6 CF			-- SF	-- CF		
EPOXY RESIN INJECTION (ERI)	ESTIMATE		ACTUAL		ESTIMATE		ACTUAL		ESTIMATE		ACTUAL		ESTIMATE		ACTUAL	
	3.0 LF				-- LF				-- LF				-- LF			
CLEANING & PAINTING EXISTING BEARINGS WITH HRSCA	ESTIMATE		ACTUAL		ESTIMATE		ACTUAL		ESTIMATE		ACTUAL		ESTIMATE		ACTUAL	
	4 EA				8 EA				8 EA				4 EA			

**LEGEND:**

- CR CONCRETE REPAIR
- SCR SHOTCRETE REPAIR
- ERI EXOXY RESIN INJECTION
- CPB CLEAN AND PAINT BEARINGS

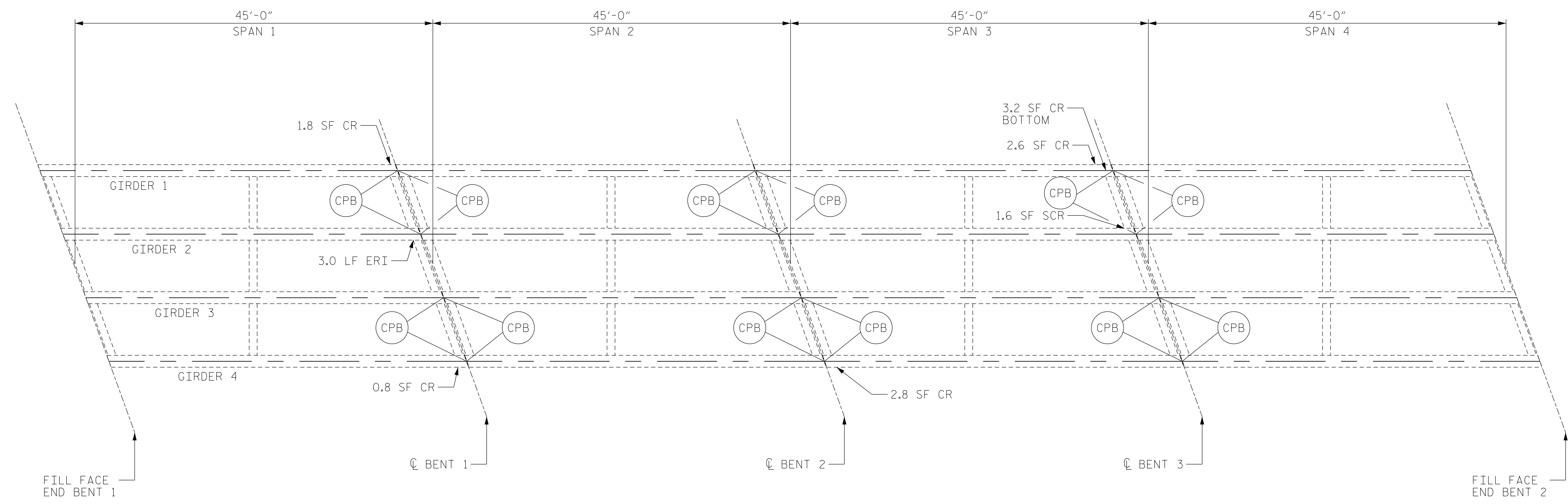

PLAN

**NOTES:**

REPAIR LOCATIONS AND ESTIMATED QUANTITIES ARE GIVEN WITH THE BEST INFORMATION AVAILABLE. IF ADDITIONAL REPAIRS NOT SHOWN ON THE DRAWINGS ARE DEEMED NECESSARY BY THE ENGINEER, THE ENGINEER WILL NOTE ON THE DRAWINGS THE APPROXIMATE LOCATIONS AND DESCRIPTION OF THE REPAIRS AND ADJUST THE ACTUAL QUANTITIES ENTERED INTO THE TABLE ABOVE.

CRACKING LOCATIONS AND QUANTITIES FOR LOCATIONS DESCRIBED AS "SCATTERED THROUGHOUT" IN THE INSPECTION REPORT ARE BASED ON THE BEST INFORMATION AVAILABLE. THE ENGINEER AND CONTRACTOR SHALL IDENTIFY AND REPAIR ALL CRACKS  $\geq 1/16"$  AS DESCRIBED IN THE SPECIAL PROVISIONS AT EACH BENT.

FOR CONCRETE AND SHOTCRETE REPAIRS, SEE "CONCRETE RESTORATION DETAILS" SHEETS.

SHOTCRETE REPAIRS MAY BE REPLACED WITH CONCRETE REPAIRS WITH THE APPROVAL OF THE ENGINEER.

PROJECT NO. I-5915B  
CATAWBA COUNTY  
 BRIDGE NO. 170178

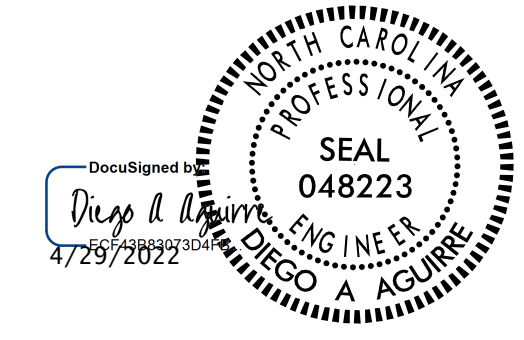

STATE OF NORTH CAROLINA  
 DEPARTMENT OF TRANSPORTATION  
 RALEIGH



### SUPERSTRUCTURE REPAIRS

REVISIONS						SHEET NO.
NO.	BY:	DATE:	NO.	BY:	DATE:	
1			3			S4-7
2			4			TOTAL SHEETS 11

DRAWN BY : ALLEN J. MCSWAIN DATE : 01/2022  
 CHECKED BY : JACOB H. DUKE DATE : 01/2022  
 DESIGN ENGINEER OF RECORD: DIEGO A. AGUIRRE DATE : 01/2022

DOCUMENT NOT CONSIDERED FINAL UNLESS ALL SIGNATURES COMPLETED

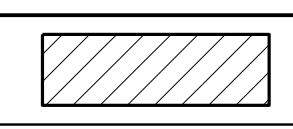
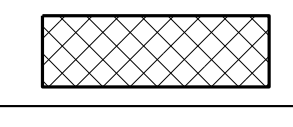

LEGEND	
	CONCRETE REPAIR AREA (CR)
	SHOTCRETE REPAIR AREA (SCR)
	EPOXY RESIN INJECTION (ERI)

	AS-BUILT REPAIR QUANTITY TABLE			
	ESTIMATE		ACTUAL	
SHOTCRETE REPAIRS	AREA SQ. FT.	VOLUME CU. FT.	AREA SQ. FT.	VOLUME CU. FT.
	CAP/BACKWALL	-	-	
COLUMN/PILE	-	-		
CONCRETE REPAIRS	AREA SQ. FT.	VOLUME CU. FT.	AREA SQ. FT.	VOLUME CU. FT.
	CAP	-	-	
EPOXY RESIN INJECTION	LIN. FT.		LIN. FT.	
	CAP/BACKWALL	6.0		
COLUMN/PILE	-			

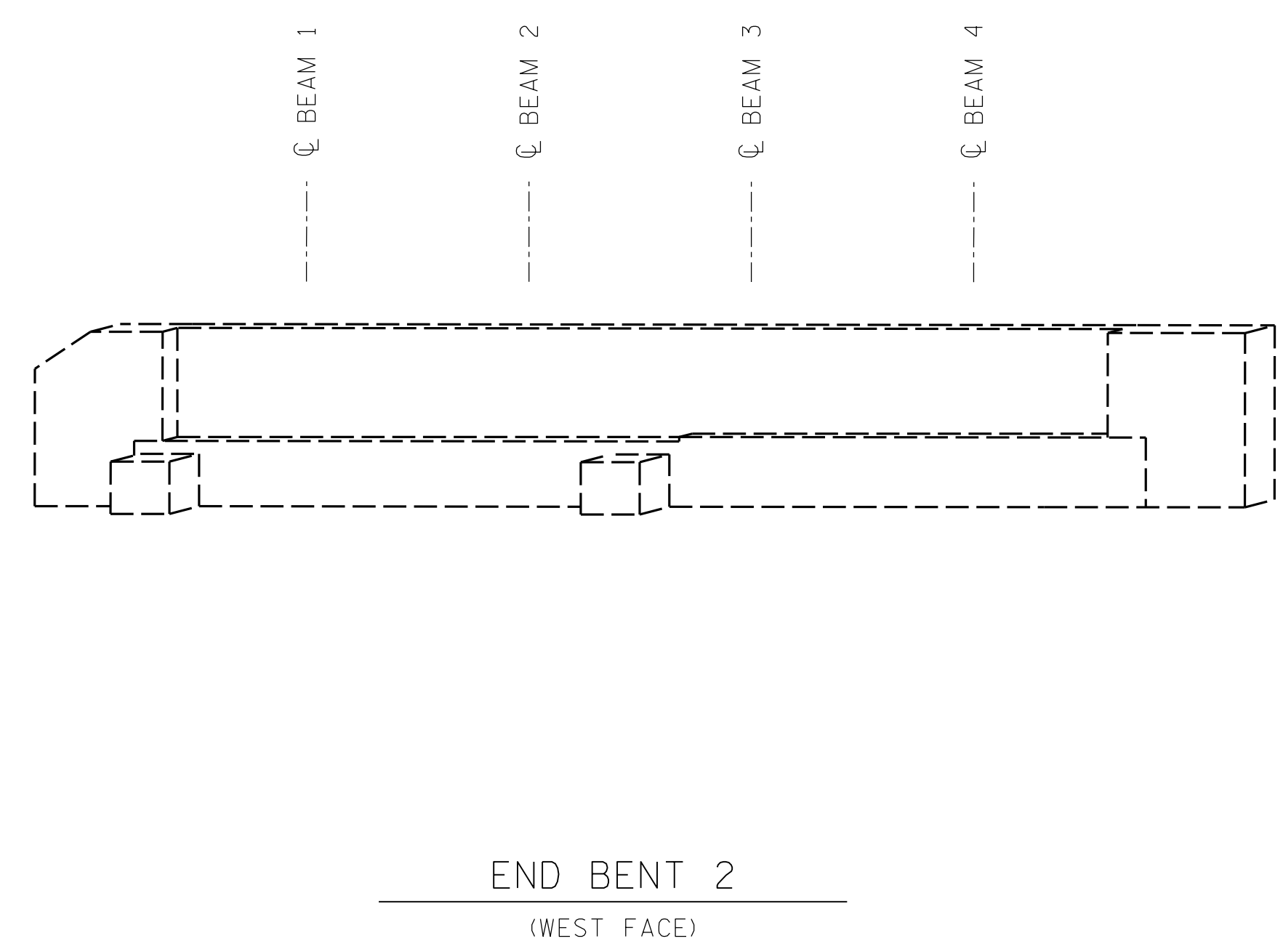
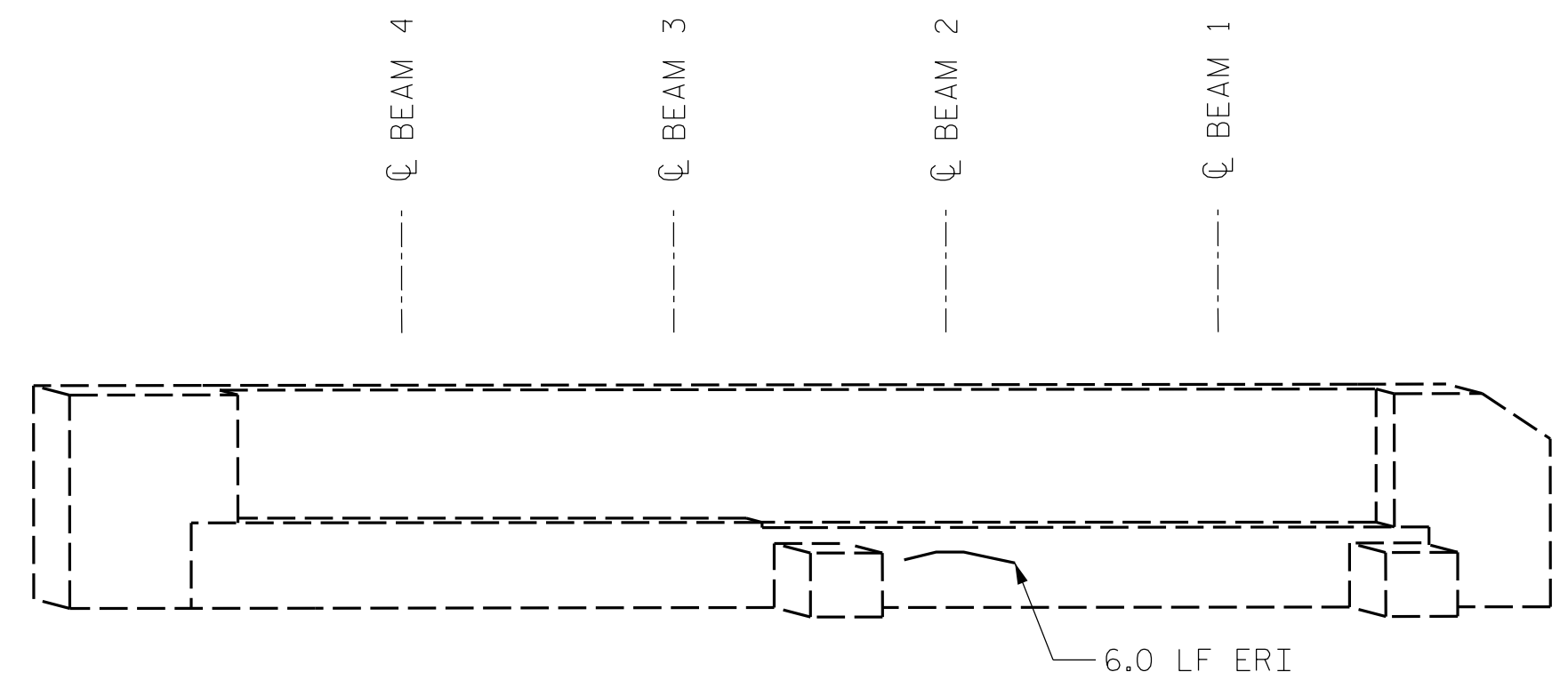

VALUES IN CHART REPRESENT ESTIMATED REPAIR TOTALS AFTER REMOVAL OF UNSOUND CONCRETE. MINIMUM OF 1" BEHIND REBAR AND MINIMUM 2" CLEARANCE TO SAWCUT. FOR REPAIR DETAILS, SEE "CONCRETE RESTORATION DETAILS" SHEETS.

**NOTES:**  
REPAIR LOCATIONS AND ESTIMATED QUANTITIES ARE GIVEN WITH THE BEST INFORMATION AVAILABLE. IF ADDITIONAL REPAIRS NOT SHOWN ON THE DRAWINGS ARE DEEMED NECESSARY BY THE ENGINEER, THE ENGINEER WILL NOTE ON THE DRAWINGS THE APPROXIMATE LOCATIONS AND DESCRIPTION OF THE REPAIRS AND ADJUST THE ACTUAL QUANTITIES ENTERED INTO THE TABLE ABOVE.

CRACKING LOCATIONS AND QUANTITIES FOR LOCATIONS DESCRIBED AS "SCATTERED THROUGHOUT" IN THE INSPECTION REPORT ARE BASED ON THE BEST INFORMATION AVAILABLE. THE ENGINEER AND CONTRACTOR SHALL IDENTIFY AND REPAIR ALL CRACKS  $\geq 1/16"$  AS DESCRIBED IN THE SPECIAL PROVISIONS AT EACH BENT.

AVERAGE CONCRETE COVER IS EXPECTED TO BE FROM 2" TO 3" ON THE CAP AND FROM 1 1/2" TO 2" ON THE PILES. ACTUAL CONCRETE COVER SHALL BE DETERMINED BY THE CONTRACTOR AND PRESENTED TO THE ENGINEER PRIOR TO BEGINNING EXCAVATION/ DEMOLITION.

FOR CONCRETE AND SHOTCRETE REPAIRS, SEE "CONCRETE RESTORATION DETAILS" SHEETS.

SHOTCRETE REPAIRS MAY BE REPLACED WITH CONCRETE REPAIRS WITH THE APPROVAL OF THE ENGINEER.

REPAIRS TO THE BENT CAP MAY REQUIRE BRIDGE JACKING. FOR BRIDGE JACKING, SEE SPECIAL PROVISIONS.

PROJECT NO. I-5915B  
CATAWBA COUNTY  
 BRIDGE NO. 170178

SHEET 1 OF 4

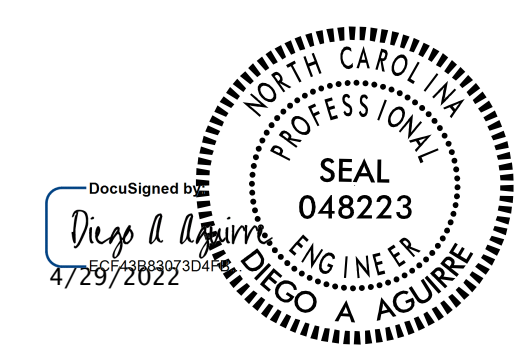

STATE OF NORTH CAROLINA DEPARTMENT OF TRANSPORTATION RALEIGH					
SUBSTRUCTURE REPAIRS					
END BENTS 1 & 2					
REVISIONS					SHEET NO.
NO.	BY:	DATE:	NO.	BY:	DATE:
1			3		
2			4		
					TOTAL SHEETS 11

DRAWN BY : ALLEN J. MCSWAIN DATE : 01/2022  
 CHECKED BY : FIDEL L. FLORES DATE : 01/2022  
 DESIGN ENGINEER OF RECORD: DIEGO A. AGUIRRE DATE : 01/2022

DOCUMENT NOT CONSIDERED  
 FINAL UNLESS ALL  
 SIGNATURES COMPLETED

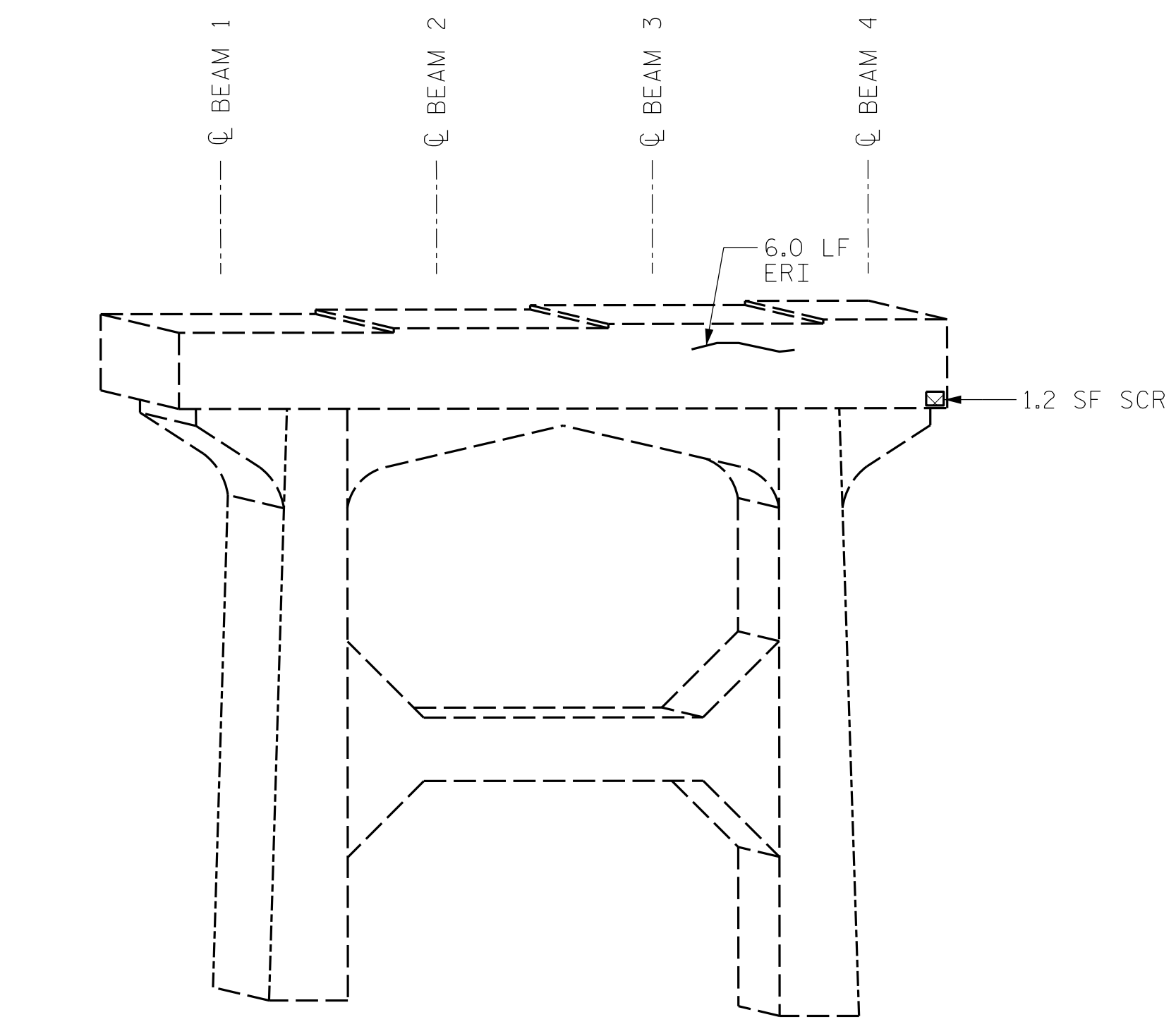

BENT 1  
(WEST FACE)

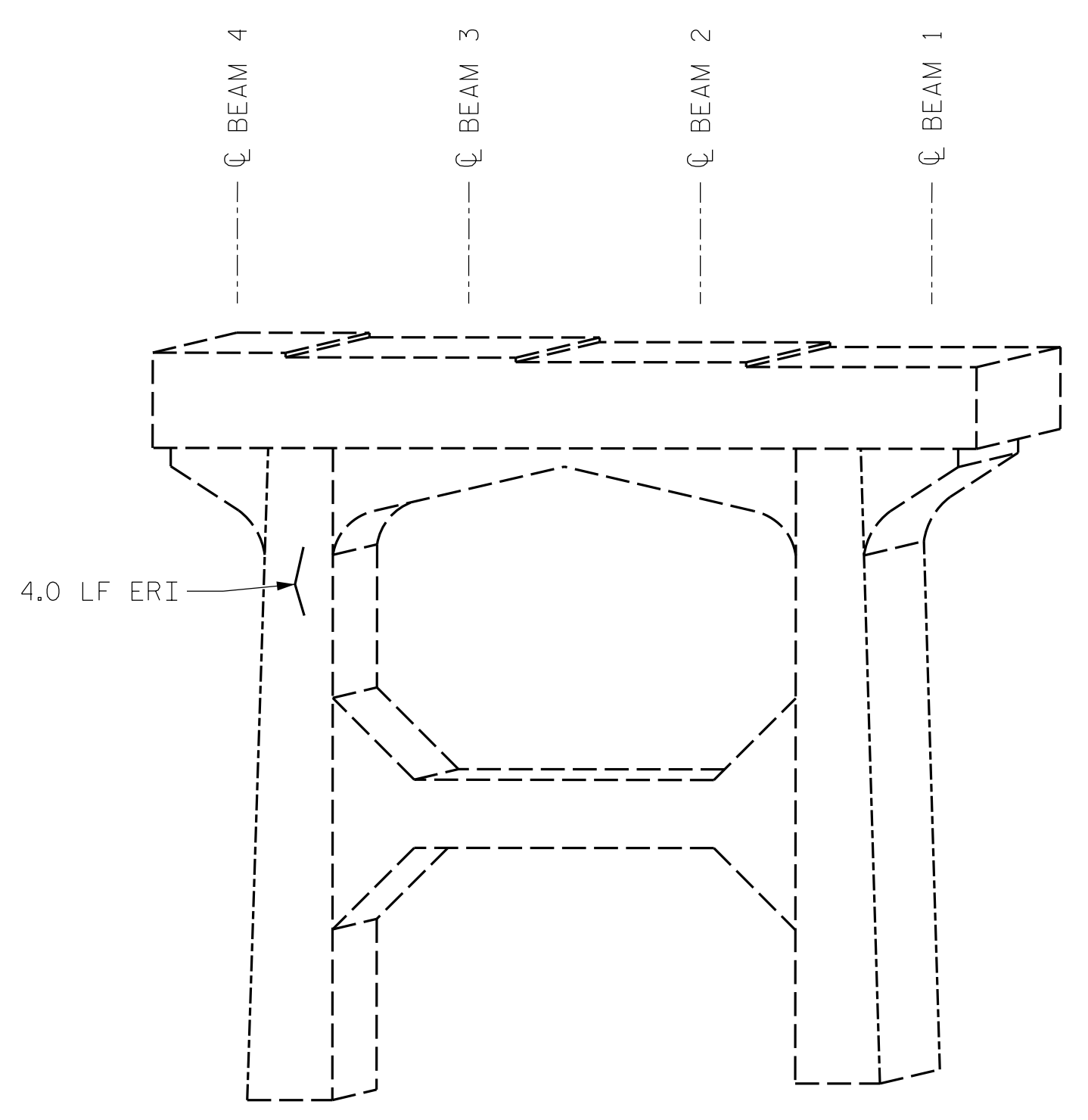

BENT 1  
(EAST FACE)

LEGEND	
	CONCRETE REPAIR AREA (CR)
	SHOTCRETE REPAIR AREA (SCR)
	EPOXY RESIN INJECTION (ERI)

	AS-BUILT REPAIR QUANTITY TABLE			
	ESTIMATE		ACTUAL	
SHOTCRETE REPAIRS	AREA SQ. FT.	VOLUME CU. FT.	AREA SQ. FT.	VOLUME CU. FT.
CAP/BACKWALL	1.2	0.4		
COLUMN/PILE	-	-		
CONCRETE REPAIRS	AREA SQ. FT.	VOLUME CU. FT.	AREA SQ. FT.	VOLUME CU. FT.
CAP	-	-		
EPOXY RESIN INJECTION	LIN. FT.		LIN. FT.	
CAP/BACKWALL	6.0			
COLUMN/PILE	4.0			

VALUES IN CHART REPRESENT ESTIMATED REPAIR TOTALS AFTER REMOVAL OF UNSOUND CONCRETE. MINIMUM OF 1" BEHIND REBAR AND MINIMUM 2" CLEARANCE TO SAWCUT. FOR REPAIR DETAILS, SEE "CONCRETE RESTORATION DETAILS" SHEETS.

**NOTES:**

REPAIR LOCATIONS AND ESTIMATED QUANTITIES ARE GIVEN WITH THE BEST INFORMATION AVAILABLE. IF ADDITIONAL REPAIRS NOT SHOWN ON THE DRAWINGS ARE DEEMED NECESSARY BY THE ENGINEER, THE ENGINEER WILL NOTE ON THE DRAWINGS THE APPROXIMATE LOCATIONS AND DESCRIPTION OF THE REPAIRS AND ADJUST THE ACTUAL QUANTITIES ENTERED INTO THE TABLE ABOVE.

CRACKING LOCATIONS AND QUANTITIES FOR LOCATIONS DESCRIBED AS "SCATTERED THROUGHOUT" IN THE INSPECTION REPORT ARE BASED ON THE BEST INFORMATION AVAILABLE. THE ENGINEER AND CONTRACTOR SHALL IDENTIFY AND REPAIR ALL CRACKS  $\geq 1/16"$  AS DESCRIBED IN THE SPECIAL PROVISIONS AT EACH BENT.

AVERAGE CONCRETE COVER IS EXPECTED TO BE FROM 2" TO 3" ON THE CAP AND FROM 1 1/2" TO 2" ON THE PILES. ACTUAL CONCRETE COVER SHALL BE DETERMINED BY THE CONTRACTOR AND PRESENTED TO THE ENGINEER PRIOR TO BEGINNING EXCAVATION/ DEMOLITION.

FOR CONCRETE AND SHOTCRETE REPAIRS, SEE "CONCRETE RESTORATION DETAILS" SHEETS.

SHOTCRETE REPAIRS MAY BE REPLACED WITH CONCRETE REPAIRS WITH THE APPROVAL OF THE ENGINEER.

REPAIRS TO THE BENT CAP MAY REQUIRE BRIDGE JACKING. FOR BRIDGE JACKING, SEE SPECIAL PROVISIONS.

PROJECT NO. I-5915B  
CATAWBA COUNTY  
 BRIDGE NO. 170178

SHEET 2 OF 4

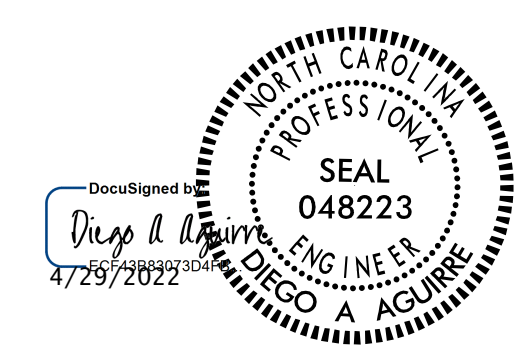

STATE OF NORTH CAROLINA  
 DEPARTMENT OF TRANSPORTATION  
 RALEIGH  
**SUBSTRUCTURE REPAIRS**  
 BENT 1



DRAWN BY : ALLEN J. MCSWAIN DATE : 01/2022  
 CHECKED BY : FIDEL L. FLORES DATE : 01/2022  
 DESIGN ENGINEER OF RECORD: DIEGO A. AGUIRRE DATE : 01/2022

DOCUMENT NOT CONSIDERED FINAL UNLESS ALL SIGNATURES COMPLETED

REVISIONS						SHEET NO.
NO.	BY:	DATE:	NO.	BY:	DATE:	
1			3			S4-9
2			4			TOTAL SHEETS 11



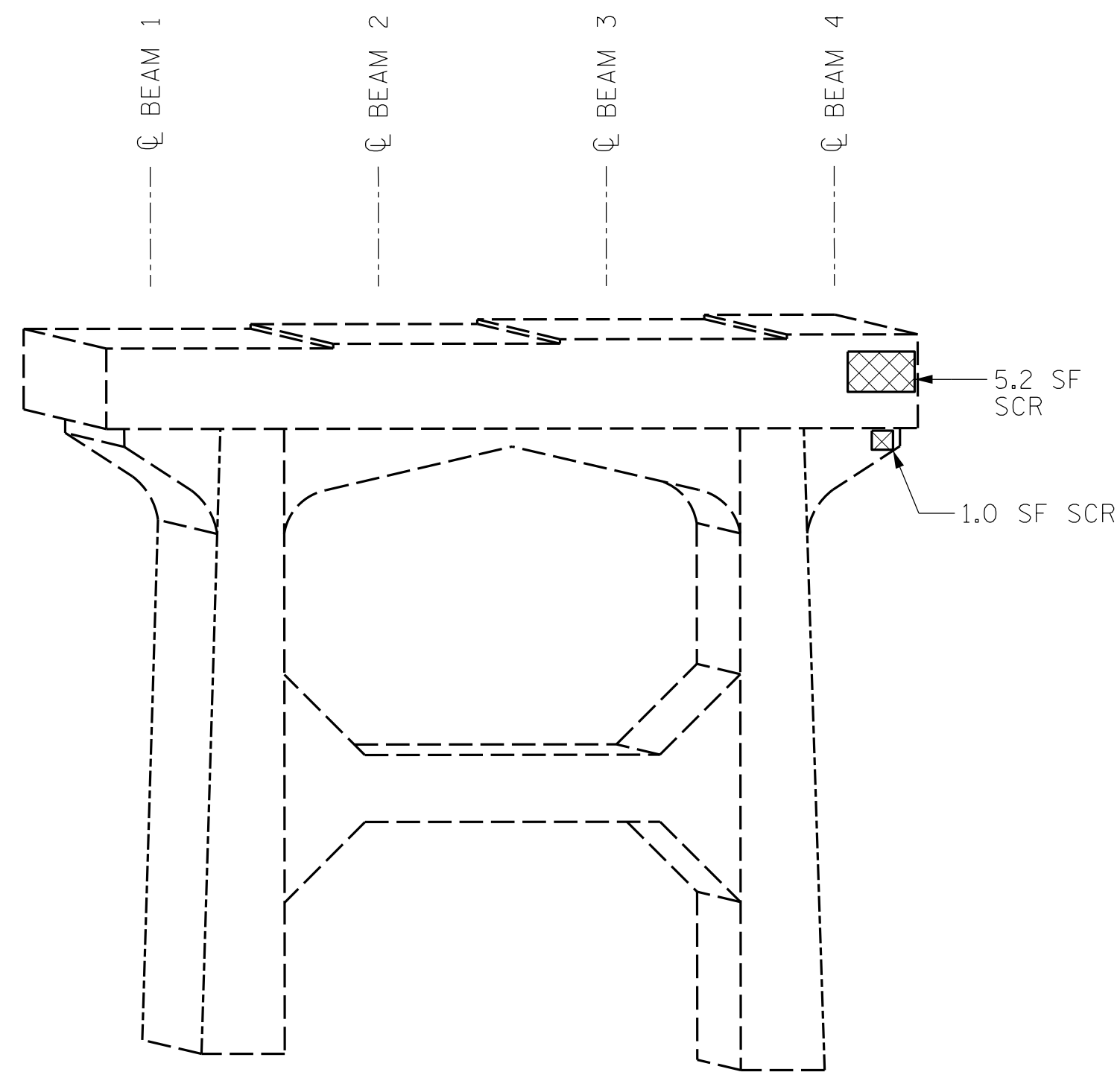

BENT 2

(WEST FACE)

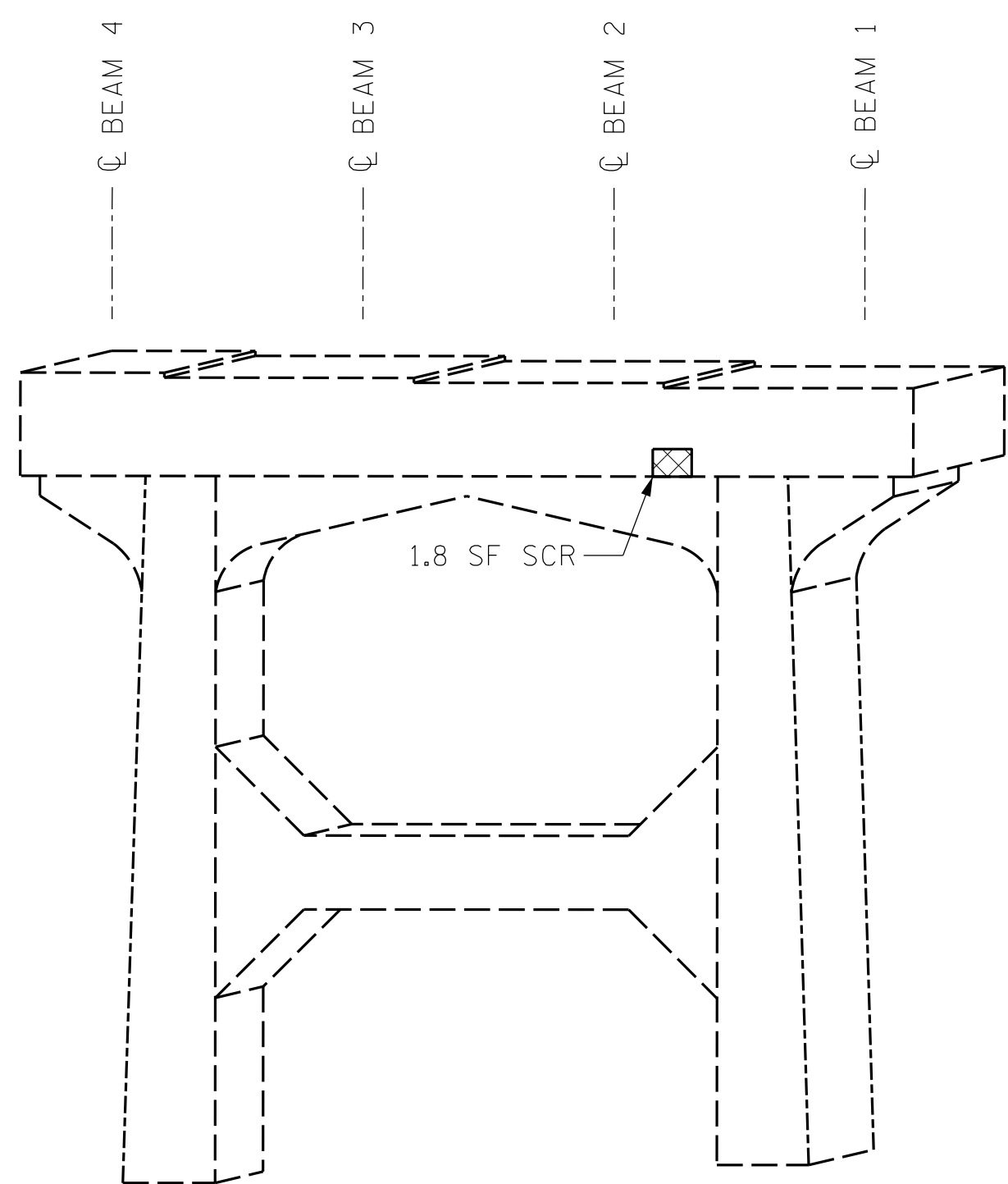

BENT 2

(EAST FACE)

LEGEND	
	CONCRETE REPAIR AREA (CR)
	SHOTCRETE REPAIR AREA (SCR)
	EPOXY RESIN INJECTION (ERI)

	AS-BUILT REPAIR QUANTITY TABLE			
	ESTIMATE		ACTUAL	
SHOTCRETE REPAIRS	AREA SQ. FT.	VOLUME CU. FT.	AREA SQ. FT.	VOLUME CU. FT.
CAP/BACKWALL	8.0	2.8		
COLUMN/PILE	-	-		
CONCRETE REPAIRS	AREA SQ. FT.	VOLUME CU. FT.	AREA SQ. FT.	VOLUME CU. FT.
CAP	-	-		
EPOXY RESIN INJECTION	LIN. FT.		LIN. FT.	
CAP/BACKWALL	-			
COLUMN/PILE	-			

VALUES IN CHART REPRESENT ESTIMATED REPAIR TOTALS AFTER REMOVAL OF UNSOUND CONCRETE. MINIMUM OF 1" BEHIND REBAR AND MINIMUM 2" CLEARANCE TO SAWCUT. FOR REPAIR DETAILS, SEE "CONCRETE RESTORATION DETAILS" SHEETS.

**NOTES:**

REPAIR LOCATIONS AND ESTIMATED QUANTITIES ARE GIVEN WITH THE BEST INFORMATION AVAILABLE. IF ADDITIONAL REPAIRS NOT SHOWN ON THE DRAWINGS ARE DEEMED NECESSARY BY THE ENGINEER, THE ENGINEER WILL NOTE ON THE DRAWINGS THE APPROXIMATE LOCATIONS AND DESCRIPTION OF THE REPAIRS AND ADJUST THE ACTUAL QUANTITIES ENTERED INTO THE TABLE ABOVE.

CRACKING LOCATIONS AND QUANTITIES FOR LOCATIONS DESCRIBED AS "SCATTERED THROUGHOUT" IN THE INSPECTION REPORT ARE BASED ON THE BEST INFORMATION AVAILABLE. THE ENGINEER AND CONTRACTOR SHALL IDENTIFY AND REPAIR ALL CRACKS  $\geq 1/16"$  AS DESCRIBED IN THE SPECIAL PROVISIONS AT EACH BENT.

AVERAGE CONCRETE COVER IS EXPECTED TO BE FROM 2" TO 3" ON THE CAP AND FROM 1 1/2" TO 2" ON THE PILES. ACTUAL CONCRETE COVER SHALL BE DETERMINED BY THE CONTRACTOR AND PRESENTED TO THE ENGINEER PRIOR TO BEGINNING EXCAVATION/ DEMOLITION.

FOR CONCRETE AND SHOTCRETE REPAIRS, SEE "CONCRETE RESTORATION DETAILS" SHEETS.

SHOTCRETE REPAIRS MAY BE REPLACED WITH CONCRETE REPAIRS WITH THE APPROVAL OF THE ENGINEER.

REPAIRS TO THE BENT CAP MAY REQUIRE BRIDGE JACKING. FOR BRIDGE JACKING, SEE SPECIAL PROVISIONS.

PROJECT NO. I-5915B  
CATAWBA COUNTY  
 BRIDGE NO. 170178

SHEET 3 OF 4



STATE OF NORTH CAROLINA  
 DEPARTMENT OF TRANSPORTATION  
 RALEIGH  
**SUBSTRUCTURE REPAIRS**  
 BENT 2

DRAWN BY : ALLEN J. MCSWAIN DATE : 01/2022  
 CHECKED BY : FIDEL L. FLORES DATE : 01/2022  
 DESIGN ENGINEER OF RECORD: DIEGO A. AGUIRRE DATE : 01/2022

4/21/2022  
 I5915B.SMU.SBR02.170178.dgn  
 daquirre

DOCUMENT NOT CONSIDERED  
 FINAL UNLESS ALL  
 SIGNATURES COMPLETED

REVISIONS						SHEET NO.
NO.	BY:	DATE:	NO.	BY:	DATE:	
1			3			S4-10
2			4			TOTAL SHEETS 11

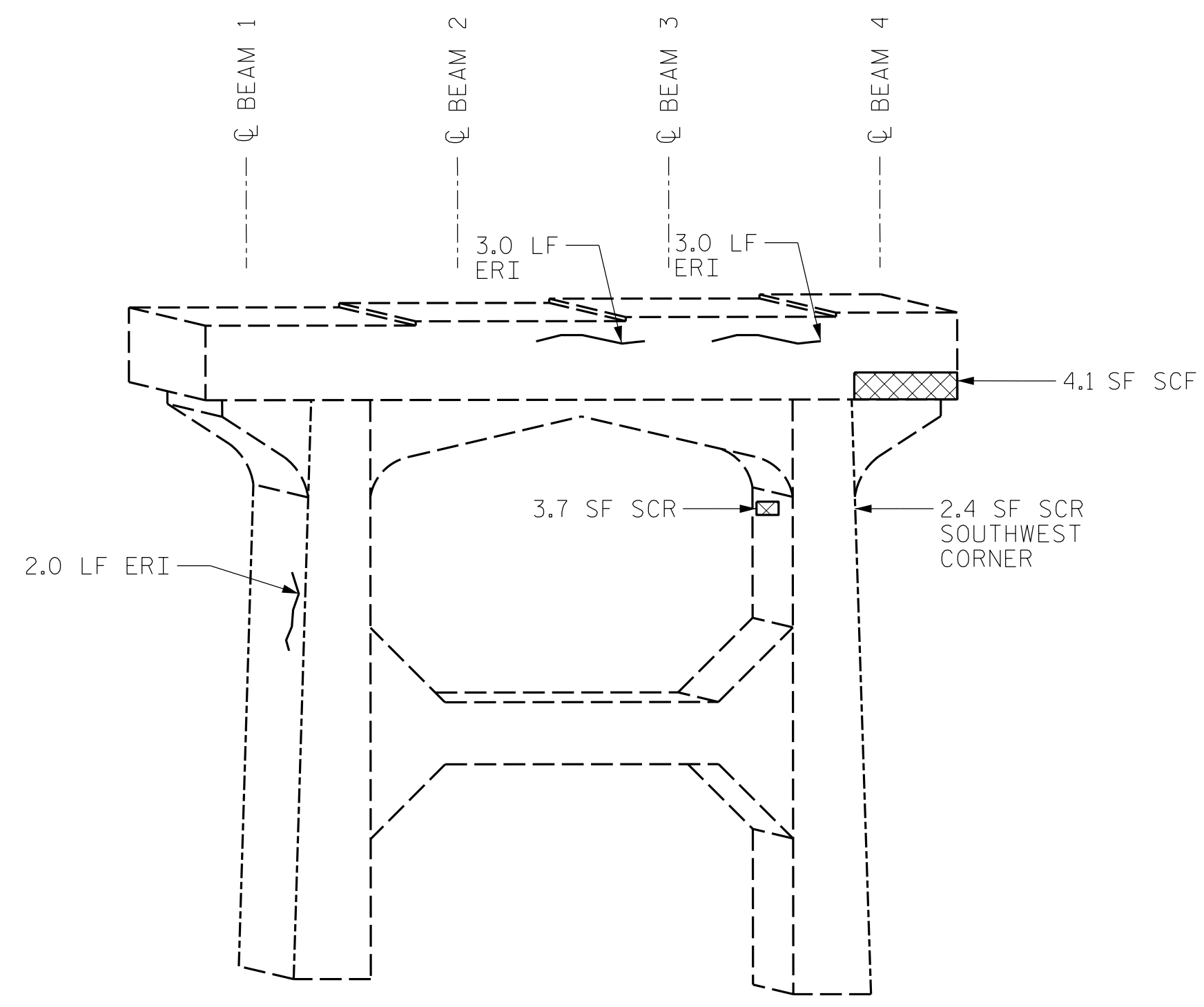

BENT 3  
(WEST FACE)

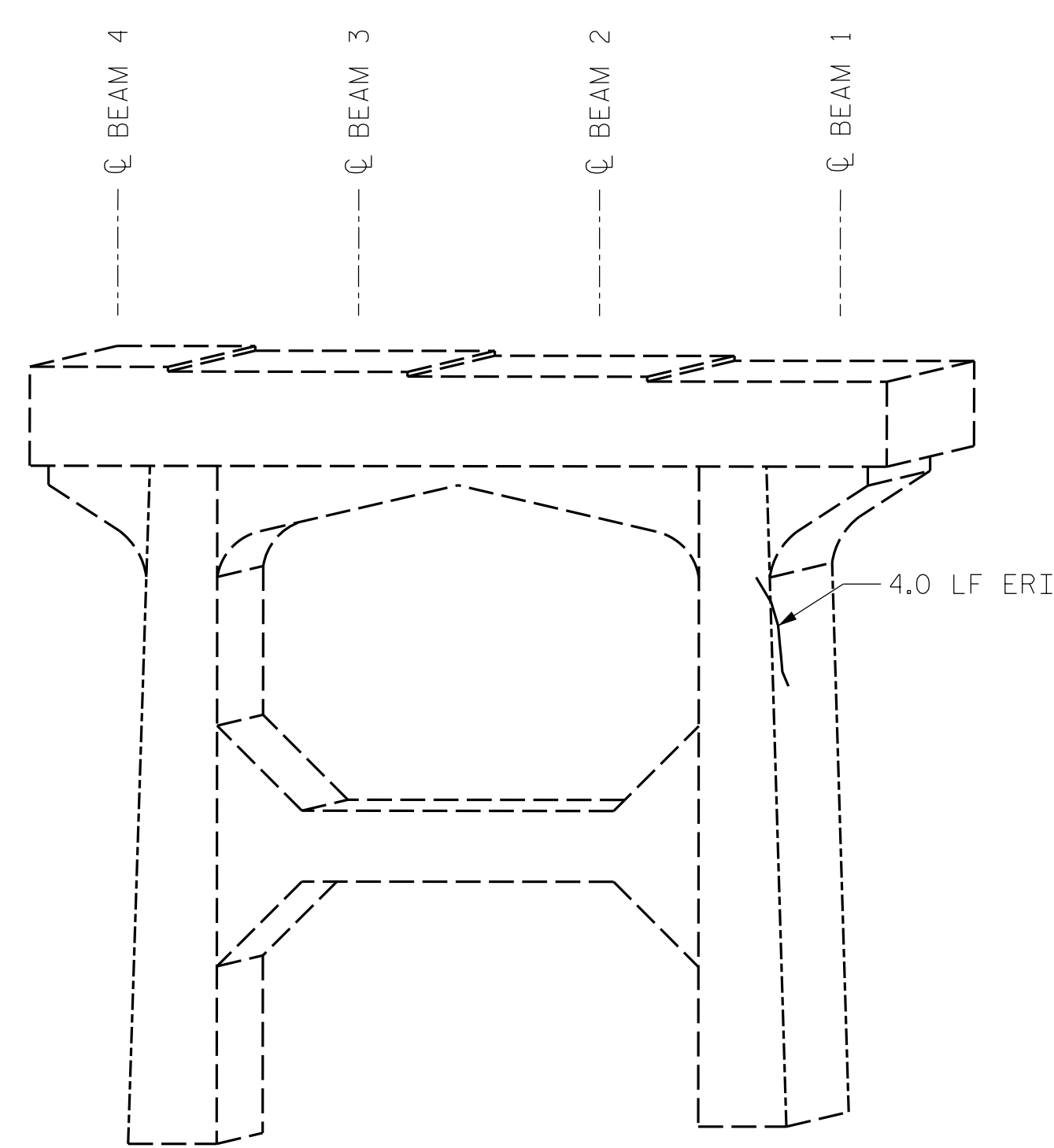

BENT 3  
(EAST FACE)

LEGEND	
	CONCRETE REPAIR AREA (CR)
	SHOTCRETE REPAIR AREA (SCR)
	EPOXY RESIN INJECTION (ERI)

	AS-BUILT REPAIR QUANTITY TABLE			
	ESTIMATE		ACTUAL	
SHOTCRETE REPAIRS	AREA SQ. FT.	VOLUME CU. FT.	AREA SQ. FT.	VOLUME CU. FT.
CAP/BACKWALL	4.1	2.1		
COLUMN/PILE	6.1	2.1		
CONCRETE REPAIRS	AREA SQ. FT.	VOLUME CU. FT.	AREA SQ. FT.	VOLUME CU. FT.
CAP	-	-		
EPOXY RESIN INJECTION	LIN. FT.		LIN. FT.	
CAP/BACKWALL	6.0			
COLUMN/PILE	6.0			

VALUES IN CHART REPRESENT ESTIMATED REPAIR TOTALS AFTER REMOVAL OF UNSOUND CONCRETE. MINIMUM OF 1" BEHIND REBAR AND MINIMUM 2" CLEARANCE TO SAWCUT. FOR REPAIR DETAILS, SEE "CONCRETE RESTORATION DETAILS" SHEETS.

**NOTES:**  
REPAIR LOCATIONS AND ESTIMATED QUANTITIES ARE GIVEN WITH THE BEST INFORMATION AVAILABLE. IF ADDITIONAL REPAIRS NOT SHOWN ON THE DRAWINGS ARE DEEMED NECESSARY BY THE ENGINEER, THE ENGINEER WILL NOTE ON THE DRAWINGS THE APPROXIMATE LOCATIONS AND DESCRIPTION OF THE REPAIRS AND ADJUST THE ACTUAL QUANTITIES ENTERED INTO THE TABLE ABOVE.

CRACKING LOCATIONS AND QUANTITIES FOR LOCATIONS DESCRIBED AS "SCATTERED THROUGHOUT" IN THE INSPECTION REPORT ARE BASED ON THE BEST INFORMATION AVAILABLE. THE ENGINEER AND CONTRACTOR SHALL IDENTIFY AND REPAIR ALL CRACKS  $\geq 1/16"$  AS DESCRIBED IN THE SPECIAL PROVISIONS AT EACH BENT.

AVERAGE CONCRETE COVER IS EXPECTED TO BE FROM 2" TO 3" ON THE CAP AND FROM 1 1/2" TO 2" ON THE PILES. ACTUAL CONCRETE COVER SHALL BE DETERMINED BY THE CONTRACTOR AND PRESENTED TO THE ENGINEER PRIOR TO BEGINNING EXCAVATION/ DEMOLITION.

FOR CONCRETE AND SHOTCRETE REPAIRS, SEE "CONCRETE RESTORATION DETAILS" SHEETS.

SHOTCRETE REPAIRS MAY BE REPLACED WITH CONCRETE REPAIRS WITH THE APPROVAL OF THE ENGINEER.

REPAIRS TO THE BENT CAP MAY REQUIRE BRIDGE JACKING. FOR BRIDGE JACKING, SEE SPECIAL PROVISIONS.

PROJECT NO. I-5915B  
CATAWBA COUNTY  
BRIDGE NO. 170178

SHEET 4 OF 4

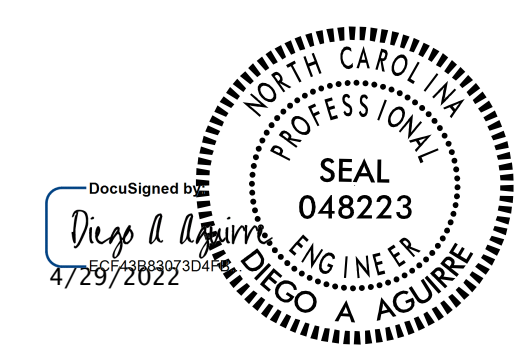

STATE OF NORTH CAROLINA  
DEPARTMENT OF TRANSPORTATION  
RALEIGH  
**SUBSTRUCTURE REPAIRS**  
BENT 3

DRAWN BY : ALLEN J. MCSWAIN DATE : 01/2022  
CHECKED BY : FIDEL L. FLORES DATE : 01/2022  
DESIGN ENGINEER OF RECORD: DIEGO A. AGUIRRE DATE : 01/2022

DOCUMENT NOT CONSIDERED FINAL UNLESS ALL SIGNATURES COMPLETED

REVISIONS						SHEET NO.
NO.	BY:	DATE:	NO.	BY:	DATE:	
1			3			S4-11
2			4			TOTAL SHEETS 11



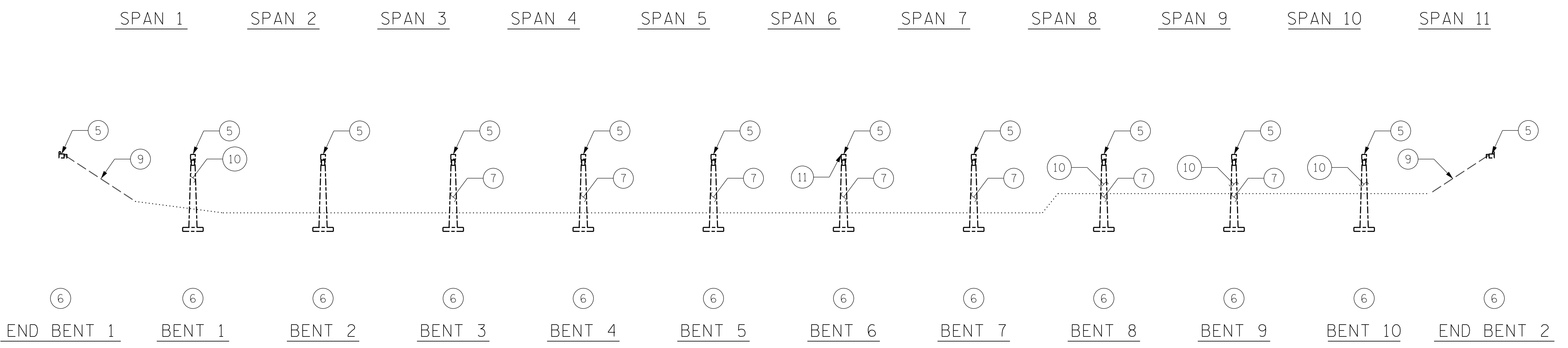

### SECTION ALONG ROADWAY

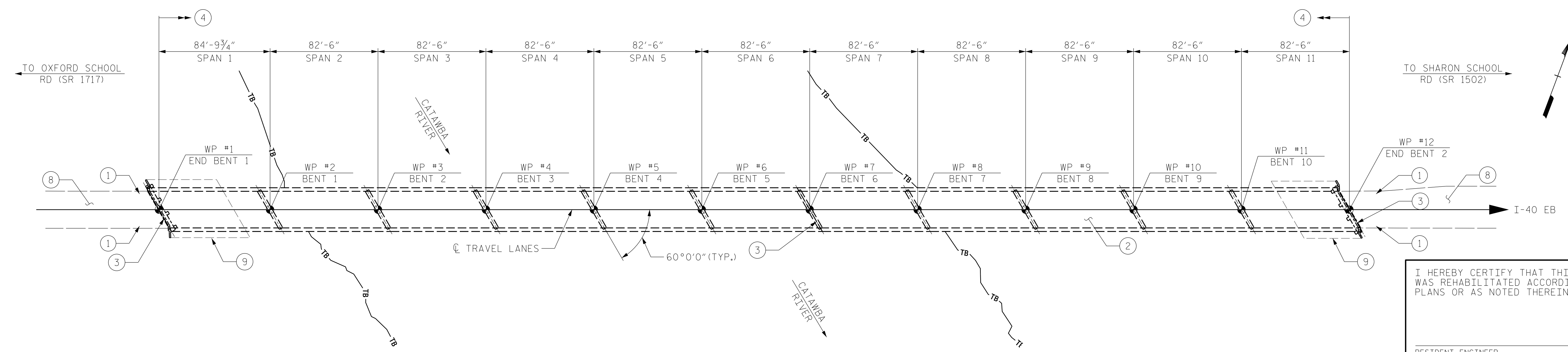

### PLAN

### SCOPE LEGEND:

- ① CLEAR SHOULDERS OF DEBRIS AND VEGETATION
- ② CONCRETE DECK REPAIRS AND SILANE DECK TREATMENT
- ③ ASPHALT JOINT REPAIR/REPLACEMENT
- ④ ADD ASPHALT WEARING SURFACE
- ⑤ PAINT EXISTING STEEL GIRDER ENDS AND ROCKER BEARINGS
- ⑥ SUBSTRUCTURE CONCRETE REPAIRS
- ⑦ SUBSTRUCTURE EPOXY RESIN INJECTION
- ⑧ APPROACH ROADWAY MILLING AND RESURFACING
- ⑨ CLEAR SLOPES AT END BENTS OF DEBRIS AND VEGETATION
- ⑩ CLEAR INTERMEDIATE BENTS OF DEBRIS AND VEGETATION
- ⑪ BEARING REPAIRS

I HEREBY CERTIFY THAT THIS STRUCTURE WAS REHABILITATED ACCORDING TO THESE PLANS OR AS NOTED THEREIN.

RESIDENT ENGINEER \_\_\_\_\_ DATE \_\_\_\_\_

PROJECT NO. I-5915B  
IREDELL COUNTY  
 BRIDGE NO. 480006

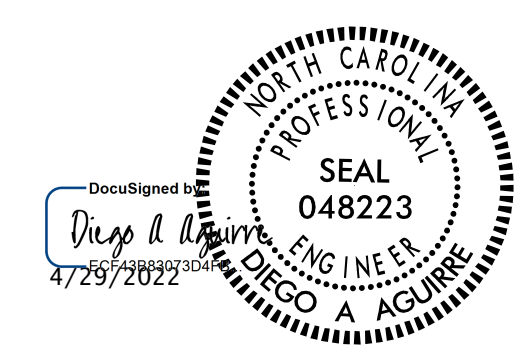

STATE OF NORTH CAROLINA  
 DEPARTMENT OF TRANSPORTATION  
 RALEIGH  
**GENERAL DRAWING**  
 FOR BRIDGE ON I-40 EB  
 OVER THE CATAWBA RIVER

### NOTES:

GENERAL DRAWING INFORMATION IS TAKEN FROM THE ORIGINAL PLANS AND THE MOST UP TO DATE ROUTINE INSPECTION REPORT DATED 09/26/2021.

DRAWN BY : FIDEL L. FLORES DATE : 01/2022  
 CHECKED BY : DIEGO A. AGUIRRE DATE : 01/2022  
 DESIGN ENGINEER OF RECORD: DIEGO A. AGUIRRE DATE : 01/2022

4/21/2022  
 I5915B.SMU.GD01.480006.dgn  
 daquirre

DOCUMENT NOT CONSIDERED FINAL UNLESS ALL SIGNATURES COMPLETED



REVISIONS						SHEET NO.	
NO.	BY:	DATE:	NO.	BY:	DATE:	S5-1	
1			3			TOTAL SHEETS	24
2			4				

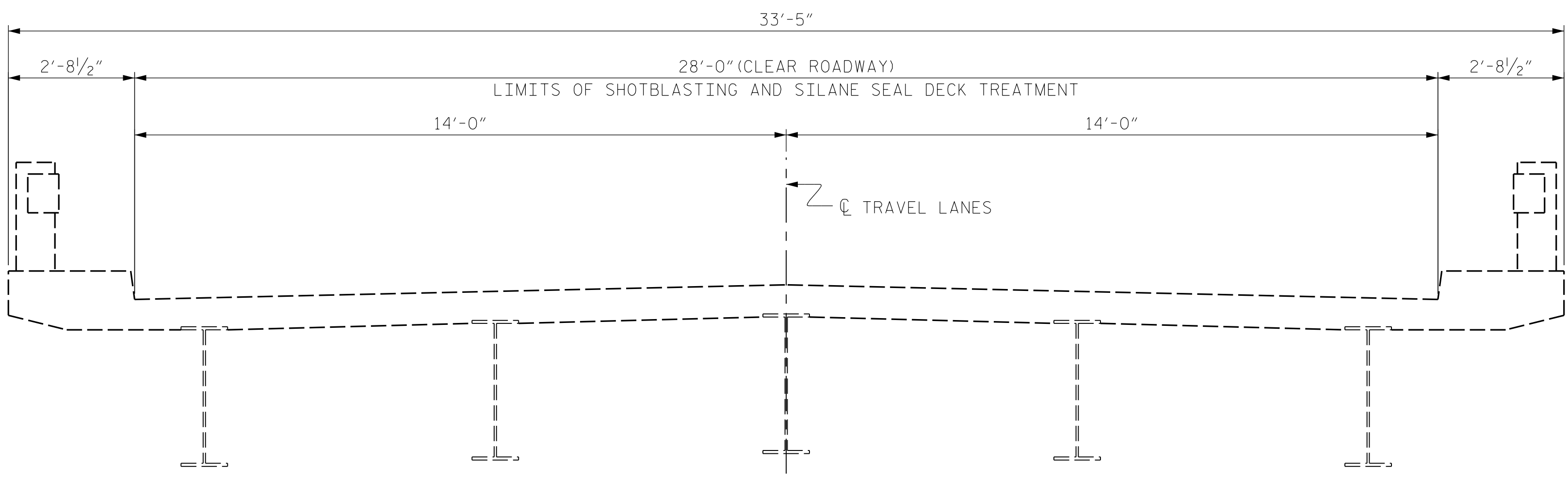

EXISTING

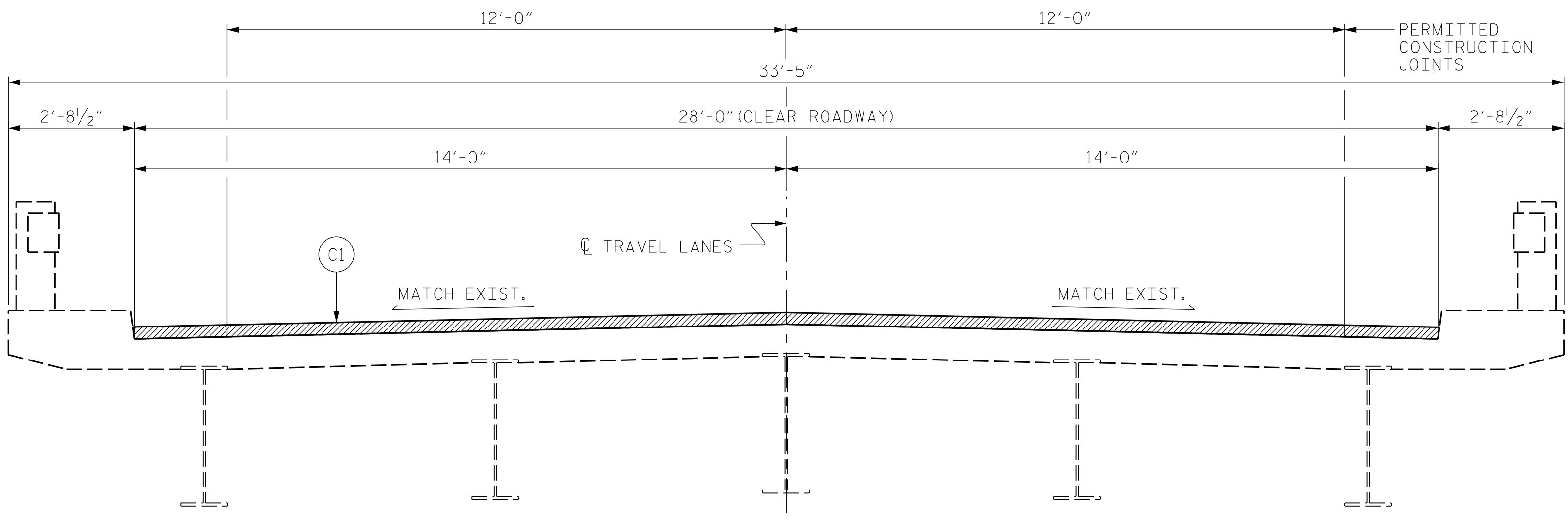

PROPOSED

**NOTES:**

LONGITUDINAL CONSTRUCTION JOINTS OF OVERLAYS SHALL BE LOCATED ALONG THE CENTERLINE OR EDGE OF TRAVEL LANES.

SEE TRAFFIC MANAGEMENT PLANS FOR LANE WIDTHS, SEQUENCING, AND OTHER TRAFFIC CONTROL MEASURES FOR STAGING OF ASPHALT WEARING SURFACE (AWS) OVERLAY.

FOR NEW ASPHALT PLACEMENT, SEE STANDARD SPECIFICATIONS.

C1	PROPOSED APPROXIMATE 2" MIN. ASPHALT CONCRETE SURFACE COURSE, TYPE S9.5C AT AN AVERAGE RATE OF 112 LBS. PER SQ. YD. PER 1" DEPTH. TO BE PLACED IN LAYERS NOT LESS THAN 1" OR GREATER THAN 2" IN DEPTH.
----	--

ASPHALT CONCRETE SURFACE COURSE, TYPE S9.5C

PROJECT NO. I-5915B  
IREDELL COUNTY  
 BRIDGE NO. 480006

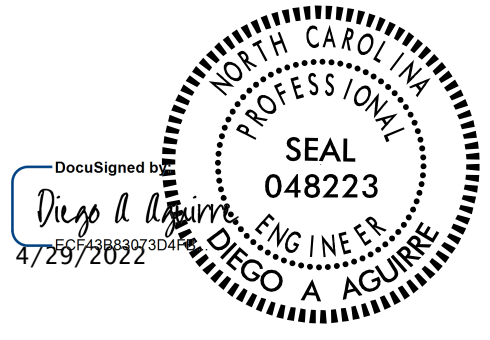

STATE OF NORTH CAROLINA  
 DEPARTMENT OF TRANSPORTATION  
 RALEIGH

TYPICAL SECTION

DRAWN BY :	DIEGO A. AGUIRRE	DATE :	01/2022
CHECKED BY :	FIDEL L. FLORES	DATE :	01/2022
DESIGN ENGINEER OF RECORD:	DIEGO A. AGUIRRE	DATE :	01/2022

DOCUMENT NOT CONSIDERED FINAL UNLESS ALL SIGNATURES COMPLETED

REVISIONS						SHEET NO.
NO.	BY:	DATE:	NO.	BY:	DATE:	S5-2
1			3			TOTAL SHEETS
2			4			24