

### BEARING REPAIRS QUANTITY TABLE

LOCATION			ESTIMATE	ACTUAL
SPAN	BENT	BEAM	(EA)	(EA)
1	END BENT 1	N/A	0	
6	BENT 6	4	1	
7	BENT 6	N/A	0	
11	END BENT 2	N/A	0	

### NOTES:

- WORK THIS SHEET WITH "SUPERSTRUCTURE REPAIRS" SHEETS.
- FOR CLEANING & PAINTING EXISTING BEARINGS WITH HRSCA, SEE SPECIAL PROVISIONS.
- BOLTS SHALL CONFORM TO THE REQUIREMENTS OF ASTM A325 AND NUTS SHALL CONFORM TO THE REQUIREMENTS OF ASTM A563 GRADE C. USE MATERIAL COMPATIBLE WASHERS, AS NEEDED.
- BOLT, NUTS, AND WASHERS SHALL BE INCIDENTAL TO THE BEARING REPAIRS PAY ITEM.
- FOR BEARING REPAIRS, SEE SPECIAL PROVISIONS.
- FOR BRIDGE JACKING, SEE SPECIAL PROVISIONS AND "BRIDGE JACKING" DETAIL SHEET.

### BEARING REPAIRS SEQUENCE:

- CLEAN AND REMOVE PACK RUST FROM ROCKER BEARING AND CONNECTING PLATES. IF, AFTER THE BEARING CLEANING PROCESS, VISIBLE STEEL CRACKS OR MORE THAN 30% SECTION LOSS ARE OBSERVED, OR IF PERMANENT DEFORMATIONS DUE TO SECTION LOSS AND PACK RUST DO NOT ALLOW ROCKER BEARINGS TO FUNCTION APPROPRIATELY, ALL WORK SHALL STOP AND THE ENGINEER SHALL BE NOTIFIED IMMEDIATELY.
- PERFORM JACKING OPERATIONS AS INDICATED IN THE "JACKING DETAILS" SHEET.
- DISCONNECT BOTH TOP AND BOTTOM ROCKER BEARING BOLTS.
- ALIGN AND/OR ROTATE ROCKER BEARINGS SUCH THAT THE VERTICAL AXIS SHALL BE AT 90° WITH RESPECT TO THE TOP FACE OF THE CAP, WITH A TOLERANCE OF +/- 2°. IN PLAN VIEW, THE CL OF THE BEARING ASSEMBLY SHALL BE ALIGNED WITH THE C GIRDER AND C BEARING LINES ON THE CAP. CONDUCT THE WORK WHEN TEMPERATURES ARE BETWEEN 45° F AND 75° F. WORK WITH THE ENGINEER TO ADJUST AS REQUIRED WHEN WORKING UNDER EXTREME TEMPERATURES.
- REPLACE MISSING/BROKEN BOLTS IN KIND AT THE GIRDER-SOLE PLATE CONNECTION, AND AT TOP ROCKER BEARING CONNECTIONS; BOLTS SHALL BE FINGER TIGHT AND THEN BACKED OFF 1/2 TURN. FOR BOTTOM ROCKER BEARING CONNECTIONS, WELD A KEEPER PLATE TO BOTH SIDES OF THE ROCKER BEARING BOTTOM FLANGE.
- CONCLUDE JACKING OPERATIONS AS INDICATED IN THE "JACKING DETAILS" SHEET.
- ENSURE THAT THE BEARINGS ARE NOT LEFT UNRESTRAINED DURING TEMPERATURE MOVEMENTS. IF THE CONTRACTOR MUST DE-MOBILIZE, WORK WITH THE ENGINEER TO PROVIDE TEMPORARY REPLACEMENT OF THE BOLTS TO PROHIBIT UNWANTED ROTATION OF THE ROCKER BEARINGS.



### EXISTING ROCKER BEARINGS

- TYPICAL DAMAGE INCLUDES:
- CORROSION AND SECTION LOSS THROUGHOUT
  - MISSING/BROKEN ROCKER BEARING BOLTS
  - MISALIGNED/ROTATED AND/OR SHIFTED ROCKER BEARINGS

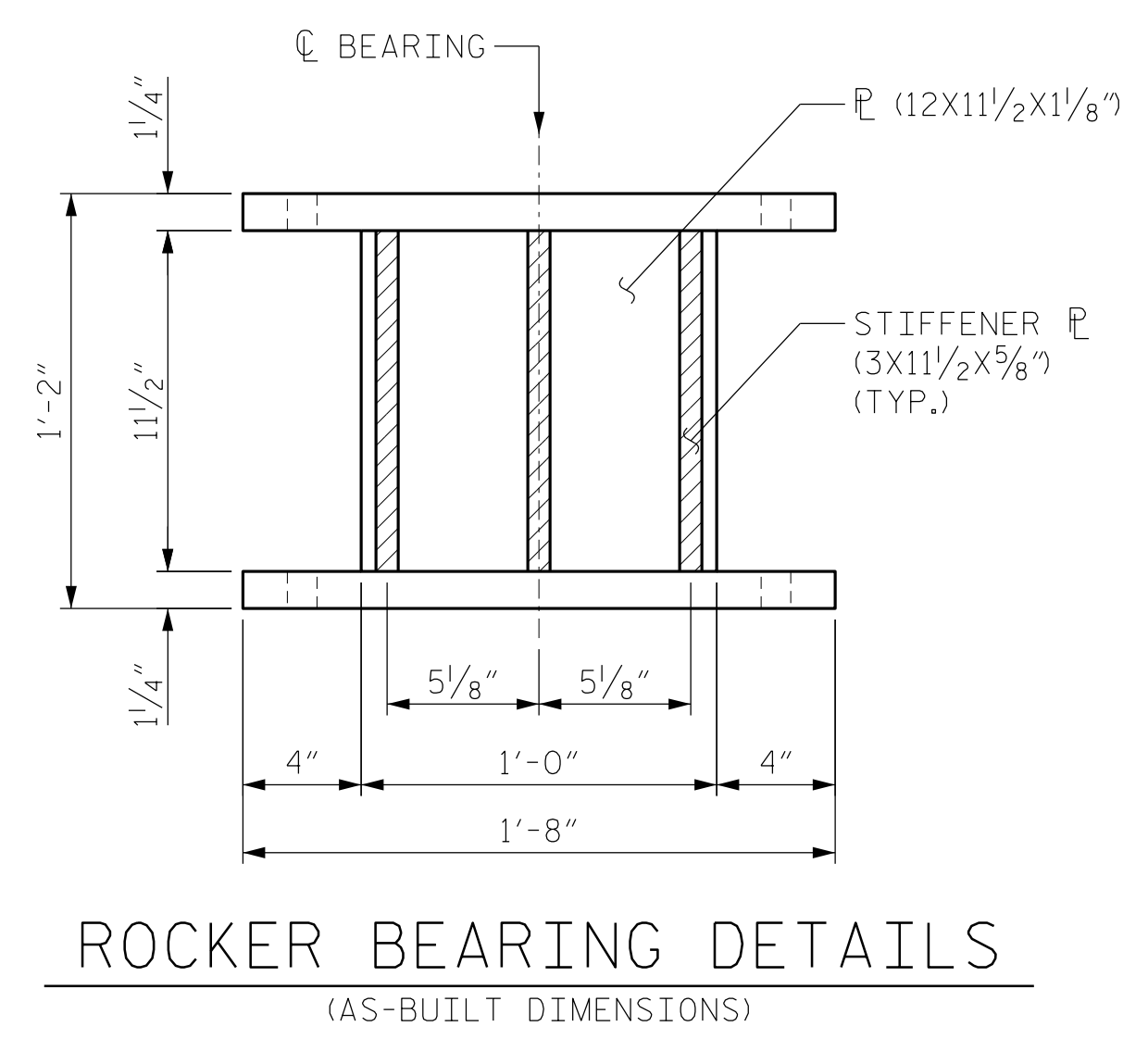
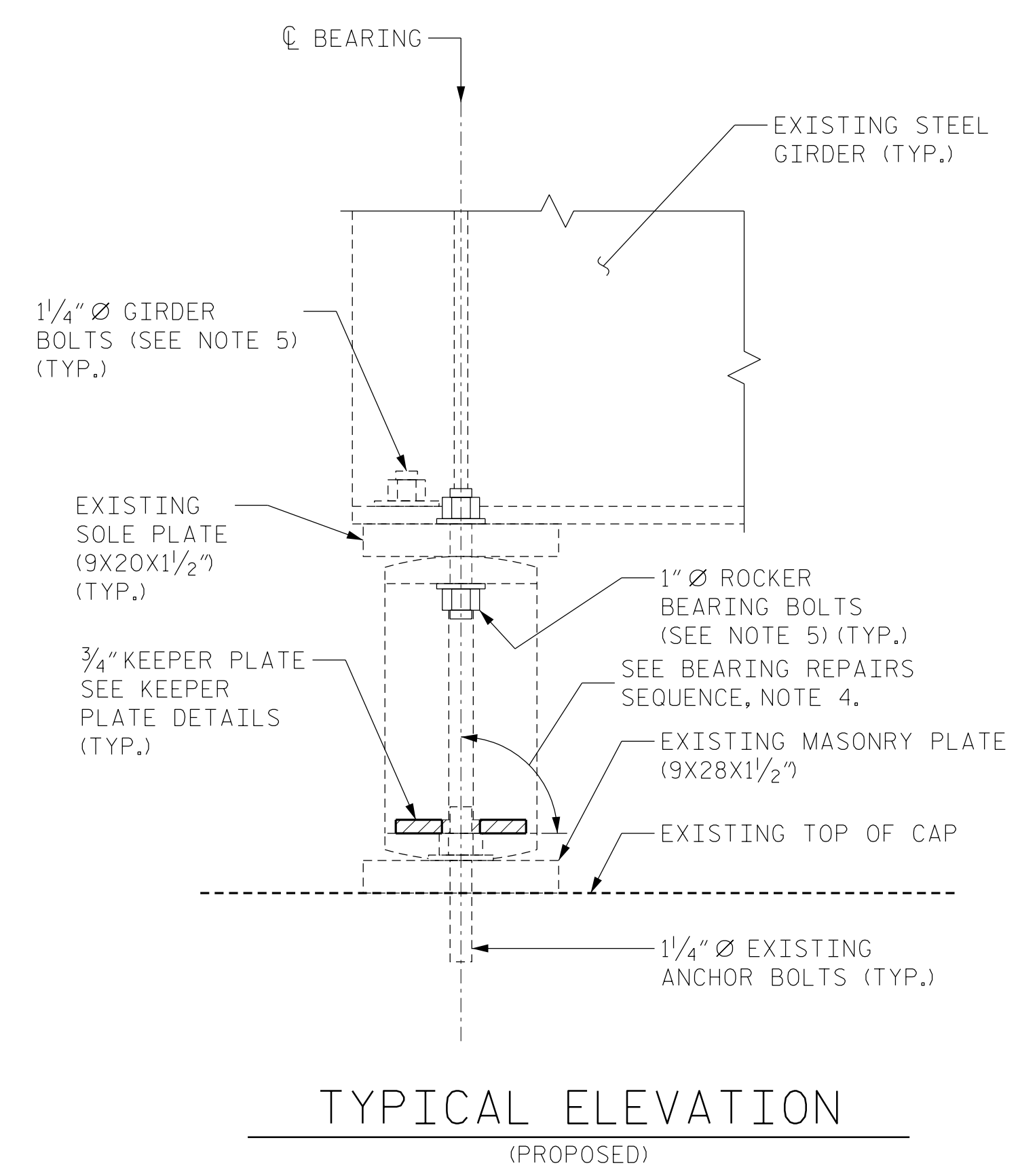
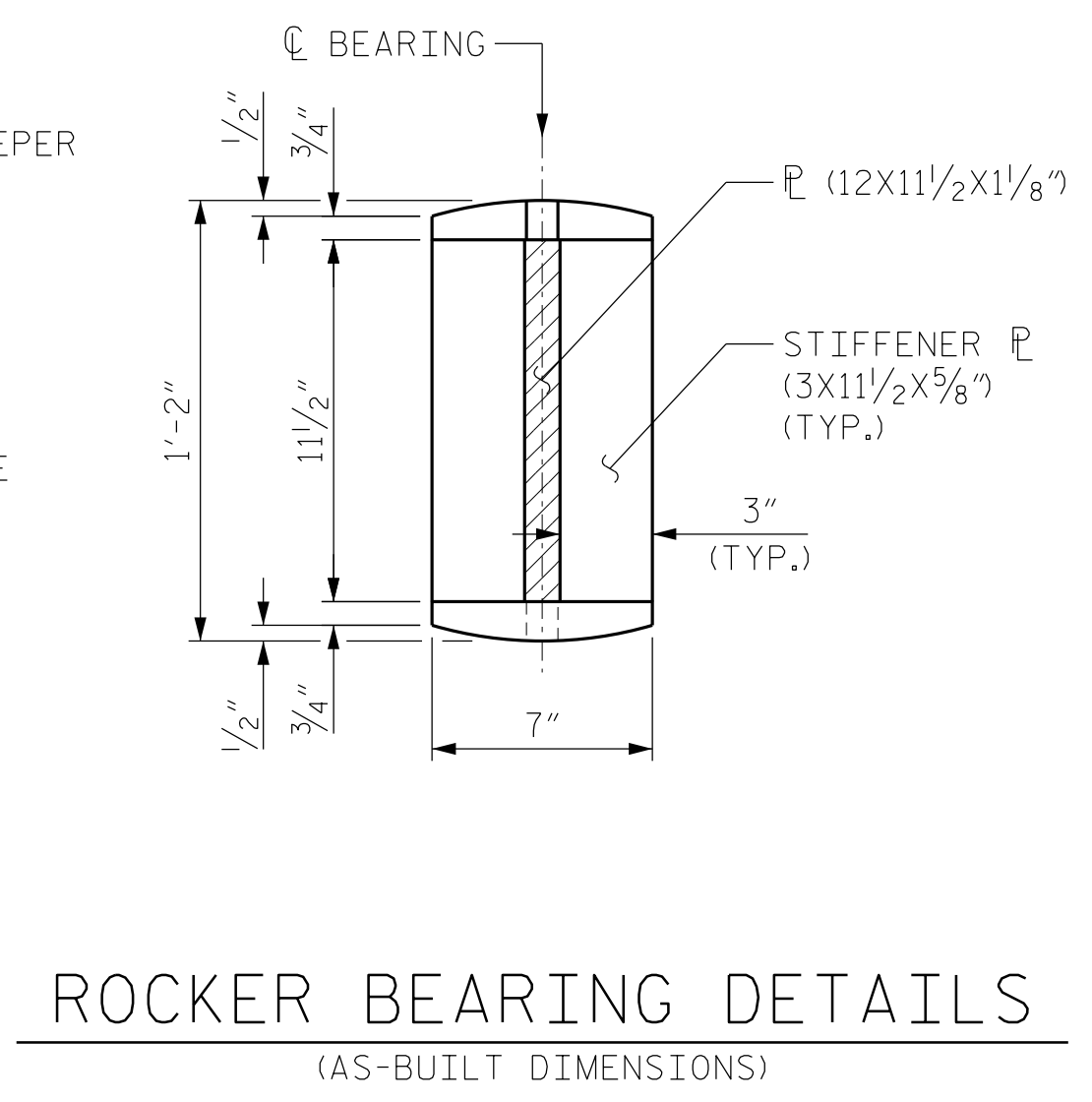
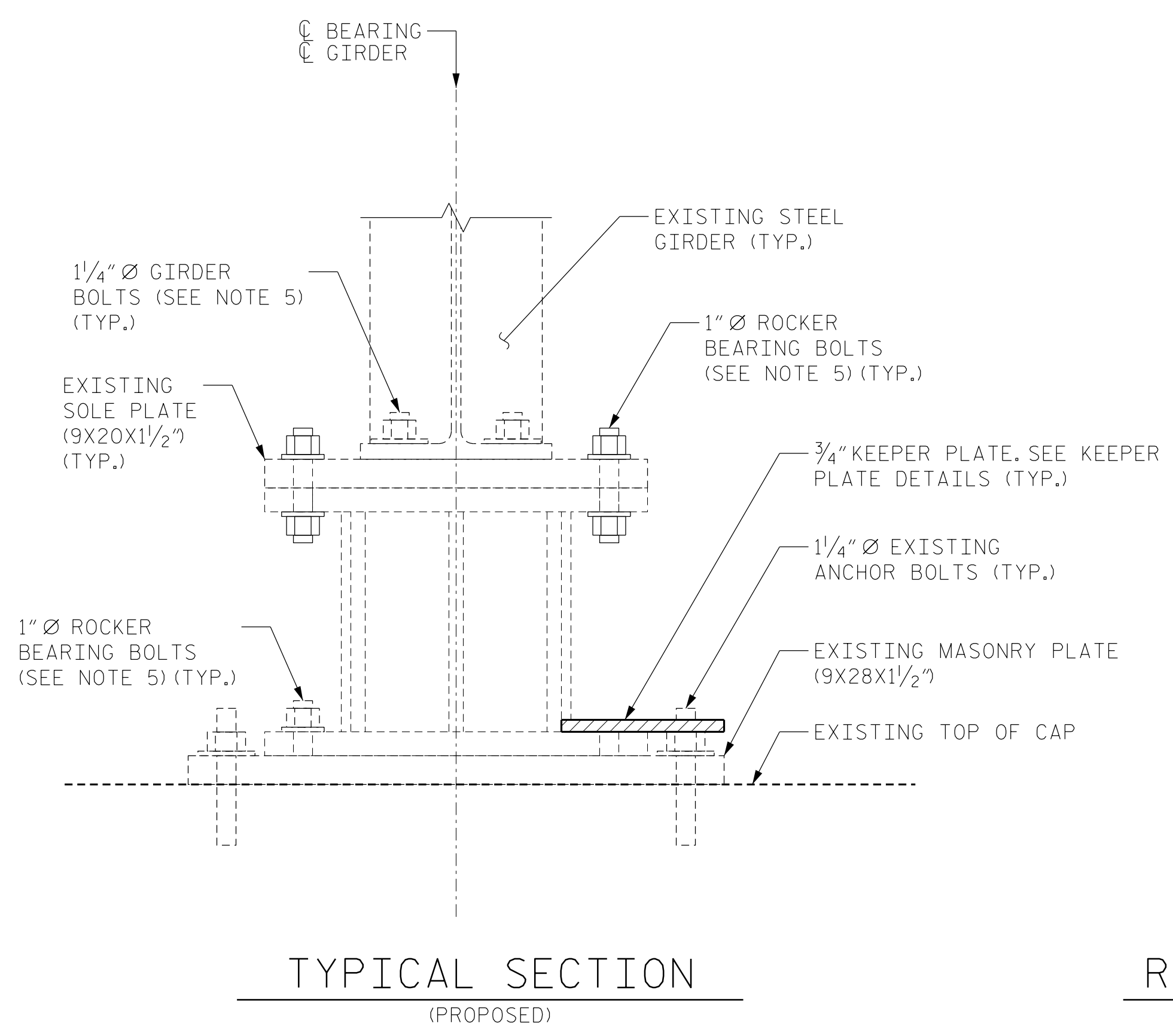
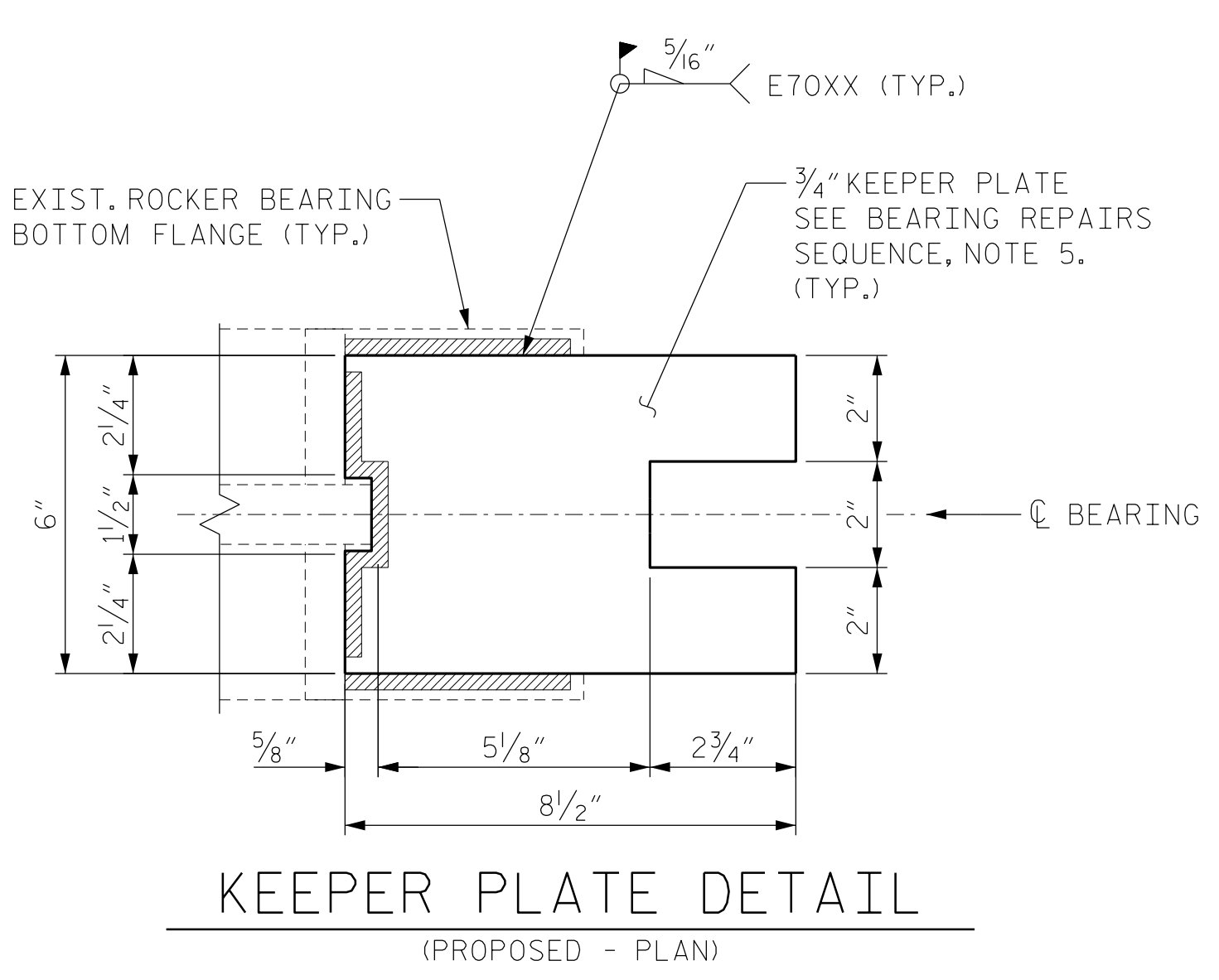

PROJECT NO. I-5915B  
IREDELL COUNTY  
 BRIDGE NO. 480006

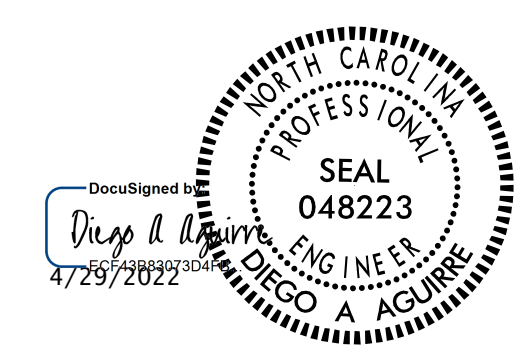

STATE OF NORTH CAROLINA  
 DEPARTMENT OF TRANSPORTATION  
 RALEIGH

## BEARING REPAIRS

DRAWN BY : DIEGO A. AGUIRRE DATE : 01/2022  
 CHECKED BY : JACOB H. DUKE DATE : 01/2022  
 DESIGN ENGINEER OF RECORD: DIEGO A. AGUIRRE DATE : 01/2022

DOCUMENT NOT CONSIDERED  
 FINAL UNLESS ALL  
 SIGNATURES COMPLETED

**KCA**  
 KISINGER CAMPO  
 & ASSOCIATES  
 301 FAYETTEVILLE ST., SUITE 1500  
 RALEIGH, NC 27601 (919) 882-7839  
 NC FIRM LICENSE: C-1506

REVISIONS						SHEET NO.
NO.	BY:	DATE:	NO.	BY:	DATE:	TOTAL SHEETS
1			3			55-13
2			4			24