

AS-BUILT REPAIR QUANTITY TABLE

SUPERSTRUCTURE REPAIRS

	SPAN 1		SPAN 2		SPAN 3		SPAN 4									
	ESTIMATE		ACTUAL		ESTIMATE		ACTUAL									
	AREA	VOLUME	AREA	VOLUME	AREA	VOLUME	AREA	VOLUME								
CONCRETE REPAIR AREA (CR)	2.5 SF	0.9 CF			26.2 SF	8.9 CF			36.2 SF	17.0 CF			18.0 SF	8.0 CF		
SHOTCRETE REPAIR AREA (SCR)	-- SF	-- CF			-- SF	-- CF			-- SF	-- CF			-- SF	-- CF		
	ESTIMATE		ACTUAL		ESTIMATE		ACTUAL		ESTIMATE		ACTUAL		ESTIMATE		ACTUAL	
CLEANING & PAINTING EXISTING BEARINGS WITH HRSCA	4 EA				8 EA				8 EA				4 EA			

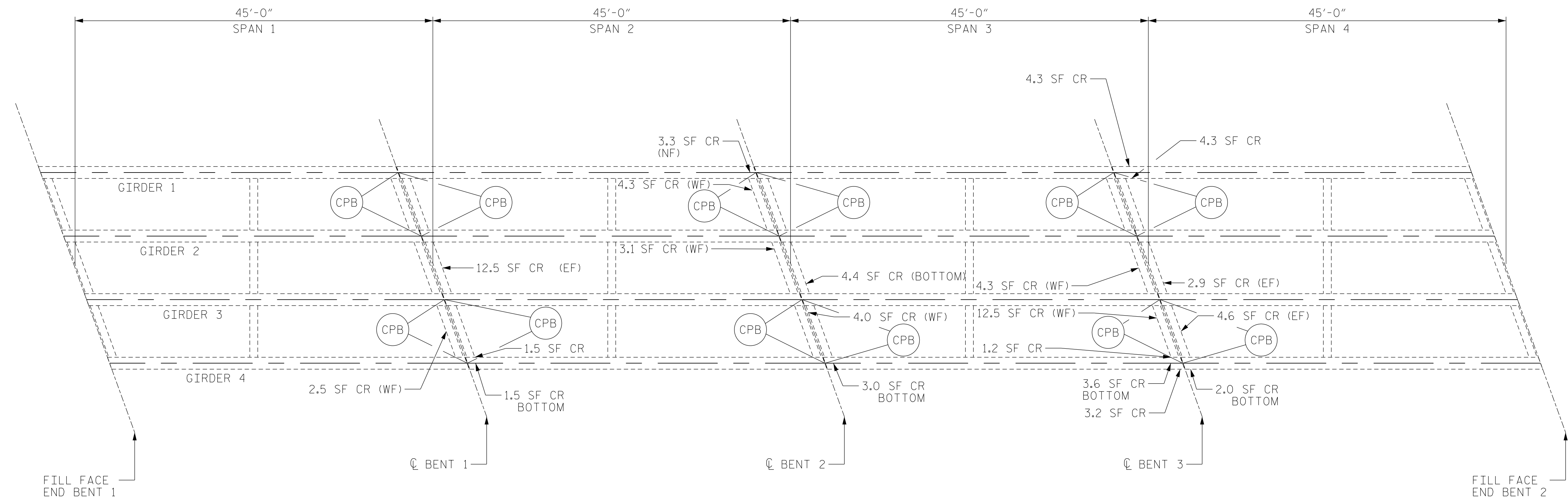

PLAN

NOTES:

REPAIR LOCATIONS AND ESTIMATED QUANTITIES ARE GIVEN WITH THE BEST INFORMATION AVAILABLE. IF ADDITIONAL REPAIRS NOT SHOWN ON THE DRAWINGS ARE DEEMED NECESSARY BY THE ENGINEER, THE ENGINEER WILL NOTE ON THE DRAWINGS THE APPROXIMATE LOCATIONS AND DESCRIPTION OF THE REPAIRS AND ADJUST THE ACTUAL QUANTITIES ENTERED INTO THE TABLE ABOVE.

CRACKING LOCATIONS AND QUANTITIES FOR LOCATIONS DESCRIBED AS "SCATTERED THROUGHOUT" IN THE INSPECTION REPORT ARE BASED ON THE BEST INFORMATION AVAILABLE. THE ENGINEER AND CONTRACTOR SHALL IDENTIFY AND REPAIR ALL CRACKS $\geq \frac{1}{16}$ " AS DESCRIBED IN THE SPECIAL PROVISIONS AT EACH BENT.

FOR CONCRETE AND SHOTCRETE REPAIRS, SEE "CONCRETE RESTORATION DETAILS" SHEETS.

SHOTCRETE REPAIRS MAY BE REPLACED WITH CONCRETE REPAIRS WITH THE APPROVAL OF THE ENGINEER.

LEGEND:

- CR CONCRETE REPAIR
- SCR SHOTCRETE REPAIR
- (CPB) CLEAN AND PAINT BEARINGS
- NF NORTH FACE
- SF SOUTH FACE
- WF WEST FACE
- EF EAST FACE

PROJECT NO. I-5915B
CATAWBA COUNTY
 BRIDGE NO. 170177

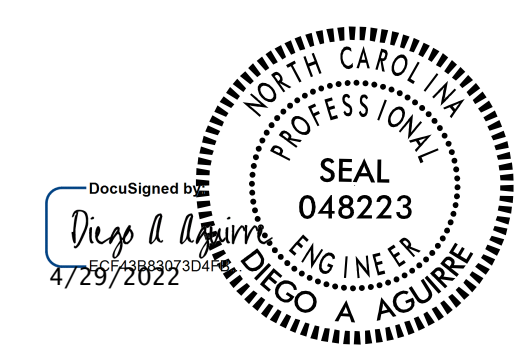

STATE OF NORTH CAROLINA
 DEPARTMENT OF TRANSPORTATION
 RALEIGH

SUPERSTRUCTURE REPAIRS

REVISIONS						SHEET NO.
NO.	BY:	DATE:	NO.	BY:	DATE:	
1			3			S3-7
2			4			TOTAL SHEETS 11

DRAWN BY : ALLEN J. MCSWAIN DATE : 01/2022
 CHECKED BY : JACOB H. DUKE DATE : 01/2022
 DESIGN ENGINEER OF RECORD: DIEGO A. AGUIRRE DATE : 01/2022

DOCUMENT NOT CONSIDERED FINAL UNLESS ALL SIGNATURES COMPLETED