

**This electronic collection of documents is provided
for the convenience of the user
and is Not a Certified Document –**

**The documents contained herein were originally issued
and sealed by the individuals whose names and license
numbers appear on each page, on the dates appearing
with their signature on that page.**

**This file or an individual page
shall not be considered a certified document.**

TIP NO. B-5717	SHEET NO. PMP-1
APPROVED: <i>Timothy A. Klotz</i> DATE: 4/25/2022	
	
DOCUMENT NOT CONSIDERED FINAL UNLESS ALL SIGNATURES COMPLETED	

**STATE OF NORTH CAROLINA
DEPARTMENT OF TRANSPORTATION**

**PAVEMENT MARKING PLAN
GUILFORD COUNTY**

**LOCATION: BRIDGES 109 AND 121 ON SR 4240 (E. GATE CITY BLVD)
OVER SOUTH BUFFALO CREEK**

T.I.P.: B-5717

CONTRACT: C204712

INDEX

SHEET NO.	DESCRIPTION
PMP-1	PAVEMENT MARKING PLAN TITLE AND SCHEDULE SHEET
PMP-2 THRU PMP-3	PAVEMENT MARKING DETAILS

GENERAL NOTES

THE FOLLOWING GENERAL NOTES APPLY AT ALL TIMES FOR THE DURATION OF THE CONSTRUCTION PROJECT, EXCEPT WHEN OTHERWISE NOTED IN THE PLAN, OR DIRECTED BY THE ENGINEER.

A) INSTALL PAVEMENT MARKINGS AND PAVEMENT MARKERS ON THE FINAL SURFACE AS FOLLOWS:

ROAD NAME	MARKING	MARKER
E. GATE CITY BLVD	THERMOPLASTIC	SNOWPLOWABLE
E. GATE CITY BLVD (BRIDGE)	COLD APPLIED PLASTIC	RAISED
CEDAR PARK RD	THERMOPLASTIC	SNOWPLOWABLE

B) TIE PROPOSED PAVEMENT MARKING LINES TO EXISTING PAVEMENT MARKING LINES.

C) REMOVE/REPLACE ANY CONFLICTING/DAMAGED PAVEMENT MARKINGS AND MARKERS.

D) STOP BAR LOCATION AT NON-SIGNALIZED INTERSECTIONS MAY BE ADJUSTED AS DIRECTED BY THE ENGINEER.

E) UNLESS OTHERWISE SPECIFIED, HEATED-IN-PLACE THERMOPLASTIC MAY BE USED IN LIEU OF EXTRUDED THERMOPLASTIC FOR STOP BARS, SYMBOLS, CHARACTERS AND DIAGONALS. IF HEATED-IN-PLACE IS USED, IT SHALL BE PAID FOR USING THE EXTRUDED THERMOPLASTIC PAY ITEM.

F) ALL BICYCLE LANE SYMBOLS SHALL BE HEATED-IN-PLACE THERMOPLASTIC. SYMBOLS SHALL BE PAID FOR USING THE HEATED-IN-PLACE PAY ITEM.

**FINAL PAVEMENT
MARKING SCHEDULE**

SYMBOL	DESCRIPTION	SYMBOL	DESCRIPTION
THERMOPLASTIC		COLD APPLIED PLASTIC	
T1	WHITE EDGELINE (4", 90 MIL)	C1	WHITE EDGELINE (4", 20 MIL)
T2	WHITE SOLID LANE LINE (4", 90 MIL)	C3	10FT. WHITE SKIP (4", 20 MIL)
T3	10FT. WHITE SKIP (4", 90 MIL)	C10	YELLOW EDGELINE (4", 20 MIL)
T4	3FT.-9FT./SP WHITE MINISKIP (4", 90 MIL)		
T5	2FT.-6FT./SP WHITE MINISKIP (4", 90 MIL)		
T10	YELLOW EDGELINE (4", 90 MIL)		
T13	YELLOW DOUBLE CENTER (4" 90 MIL)		
T43	WHITE SOLID LANE LINE (8", 90 MIL)		
T44	3FT.-9FT./SP WHITE MINISKIP (8", 90 MIL)		
T51	WHITE DIAGONAL (12", 90 MIL)		
T61	WHITE STOPBAR (24", 90 MIL)		
T62	WHITE CROSSWALK (24", 90 MIL)		
T70	LEFT TURN ARROW (90 MIL)		
T71	RIGHT TURN ARROW (90 MIL)		
T72	STRAIGHT ARROW (90 MIL)		
T73	COMBO. LEFT/STRAIGHT ARROW (90 MIL)		
T74	COMBO. RIGHT/STRAIGHT ARROW (90 MIL)		
T77	U-TURN ARROW (90 MIL)		
T78	COMBO. LEFT/U-TURN ARROW (90 MIL)		
T90	BICYCLE SYMBOL, HEATED-IN-PLACE (90 MIL)		
T91	BICYCLE STRAIGHT ARROW, HEATED-IN-PLACE (90 MIL)		
T100	ALPHANUMERIC CHAR. (90 MIL)		

ROADWAY STANDARD DRAWING

THE FOLLOWING ROADWAY STANDARDS AS APPEAR IN "ROADWAY STANDARD DRAWINGS" - PROJECT SERVICES UNIT - N.C. DEPARTMENT OF TRANSPORTATION - RALEIGH, N.C., DATED JANUARY 2018 ARE APPLICABLE TO THIS PROJECT AND BY REFERENCE HEREBY ARE CONSIDERED A PART OF THESE PLANS:

STD. NO.	TITLE
1205.01	PAVEMENT MARKINGS - LINE TYPES AND OFFSETS
1205.02	PAVEMENT MARKINGS - TWO-LANE AND MULTILANE ROADWAYS
1205.04	PAVEMENT MARKINGS - INTERSECTIONS
1205.05	PAVEMENT MARKINGS - TURN LANES
1205.06	PAVEMENT MARKINGS - LANE DROPS
1205.07	PAVEMENT MARKINGS - PEDESTRIAN CROSSINGS
1205.08	PAVEMENT MARKINGS - SYMBOLS AND WORD MESSAGES
1205.09	PAVEMENT MARKINGS - PAINTED ISLANDS
1205.12	PAVEMENT MARKINGS - BRIDGES
1250.01	RAISED PAVEMENT MARKERS - INSTALLATION SPACING
1251.01	RAISED PAVEMENT MARKERS - PERMANENT AND TEMPORARY
1253.01	RAISED PAVEMENT MARKERS - SNOWPLOWABLE
1261.01	GUARDRAIL AND BARRIER DELINEATORS - INSTALLATION SPACING
1261.02	GUARDRAIL AND BARRIER DELINEATORS - TYPES AND MOUNTING
1262.01	GUARDRAIL END DELINEATION
1264.01	OBJECT MARKERS - TYPES
1264.02	OBJECT MARKERS - INSTALLATION

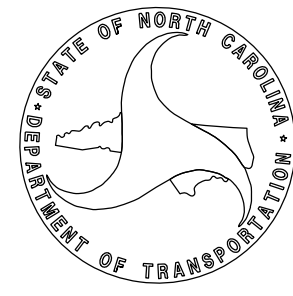
PLAN SUBMITTED TO:	
DAVID STUTTS, PE	

PLAN PREPARED BY:	AECOM
GREGORY COLS, PE	PROJECT ENGINEER
TIMOTHY KLOTZ, PE	DESIGN ENGINEER

NC FIRM LICENSE No: F-0342
5438 Wade Park Boulevard, Suite 200
Raleigh, NC 27617
(919) 461-1100

3/7/2022
p4:\aecom-ne-pw\bentley.com\AECOM_DS21_NA_2020\Documents\60592827-NCDDOT_SMU_B-5717\900-CAD_GIS\910_CAD_70_NCDOT_TIP\Traffic\NMP\B5717_pmp_psh01.tsh.dgn
Tim.Klotz

TIP NO. B-5717	SHEET NO. PMP-2
APPROVED: <i>Timothy A. Klotz</i> Professional Engineer No. 046210	
DATE: 4/25/2022	
SEAL 	
DOCUMENT NOT CONSIDERED FINAL UNLESS ALL SIGNATURES COMPLETED	
AECOM NC FIRM LICENSE No. F-0342 5438 Wade Park Boulevard, Suite 200 Raleigh, NC 27607 1997-461-1103	

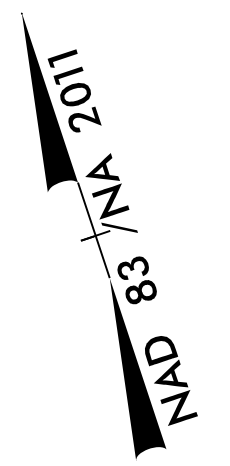

CURB RAMP LOCATIONS

① -L- 15+35 +/- 56' RT (TYPE 1)

BEGIN TIP PROJECT B-5717
-L- STA 11+00.00
TIE TO EXISTING MARKINGS

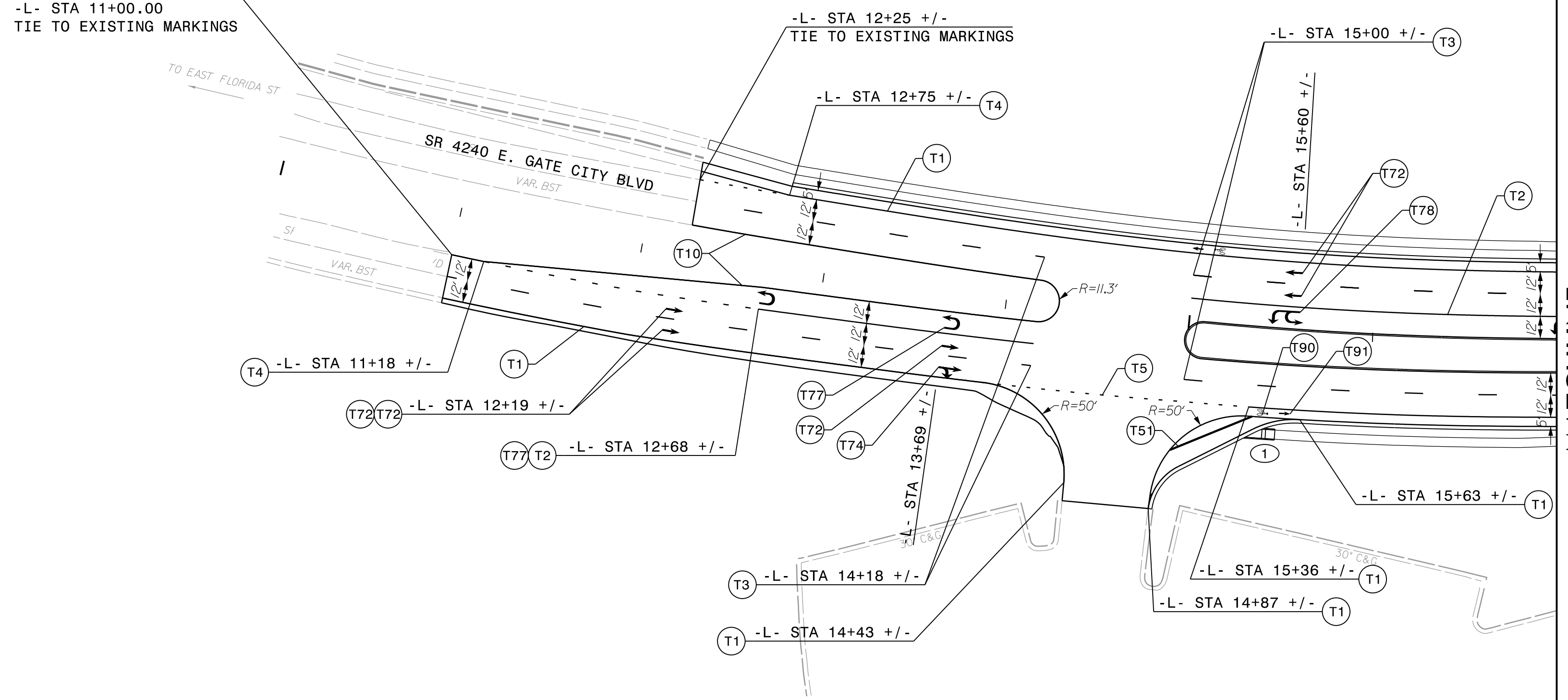

MATCHLINE
-L- STA 17 + 00.00
SEE SHEET PMP-3

PAVEMENT MARKING DETAIL

3/7/2022
p:\aecom-na-pw-bentley.com\AECOM_DS21_NA_2020\Documents\60592827-NC001_SMU B-5717\900-CAD_GIS\910-CAD\TO_NCD01_TIP\Tranffic\PM\B5717_pmp_psh02.dgn
Tim.Klotz

TIP NO. B-5717	SHEET NO. PMP-3
APPROVED: <i>Timothy A. Klotz</i> SEAL 046210 ENGINEER TIMOTHY A. KLOTZ	
DATE: 4/25/2022	
SEAL	
<p style="text-align: center;">DOCUMENT NOT CONSIDERED FINAL UNLESS ALL SIGNATURES COMPLETED</p> <p>AECOM <small>NC FIRM LICENSE No. F-0342 5438 Wade Park Boulevard, Suite 200 Raleigh, NC 27607 1997-461-1100</small></p>	

- CURB RAMP LOCATIONS**
- ② -L- 24+80 +/- 59' LT (TYPE 1A)
 - ③ -L- 24+80 +/- 6' LT (M.I. CUT THROUGH)
 - ④ -L- 24+80 +/- 58' RT (TYPE 3)
 - ⑤ -L- 25+25 +/- 97' RT (TYPE 2)
 - ⑥ -L- 25+58 +/- 97' RT (TYPE 1)
 - ⑦ -L- 27+07 +/- 57' RT (TYPE 1)

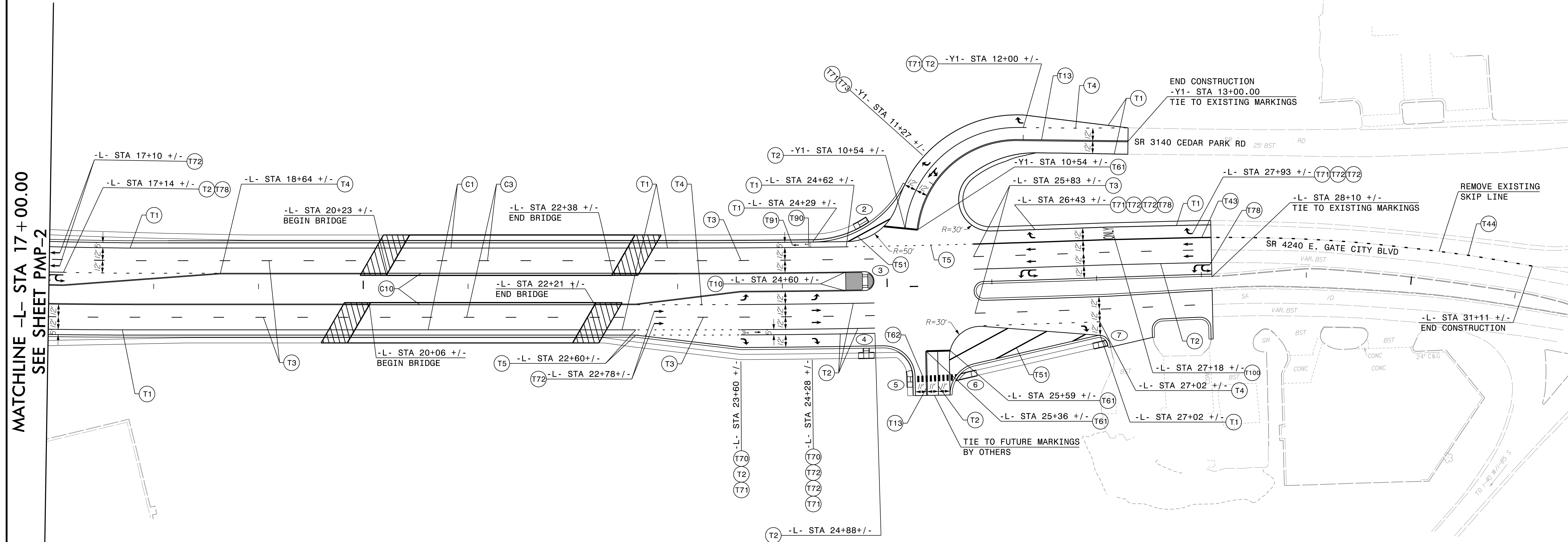
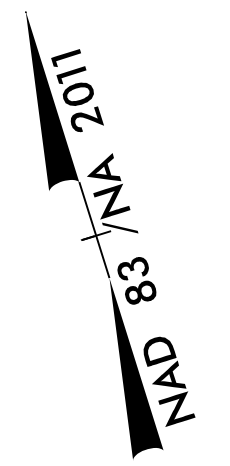

MATCHLINE -L- STA 17+00.00
SEE SHEET PMP-2

PAVEMENT MARKING DETAIL

3/7/2022
p:\aecom-na-pw-bentley.com\AECOM_DS21_NA_2020\Documents\60592827-NC001_SMU B-5717\900-CAD_GIS\910-CAD\70-NC001_TIP\Tranfig\PM\B5717_pmp_psh03.dgn
Tim.Klotz