

DATE: 3/31/2022
TIME: 3:07:52 PM

USER: pnt@acum.com
DIR: pva@acum.com
DRAWING: C:\Users\pva\Documents\AECOM\2020\Documents\60592827-NCDDT_SMU_B-5717\900-CAD_GIS\910_CAD\TO_NCDDT_TIPS\Structures\04_Drawings\M02_035_B-5717_SMU_CBR2_S2-18_4001.dgn

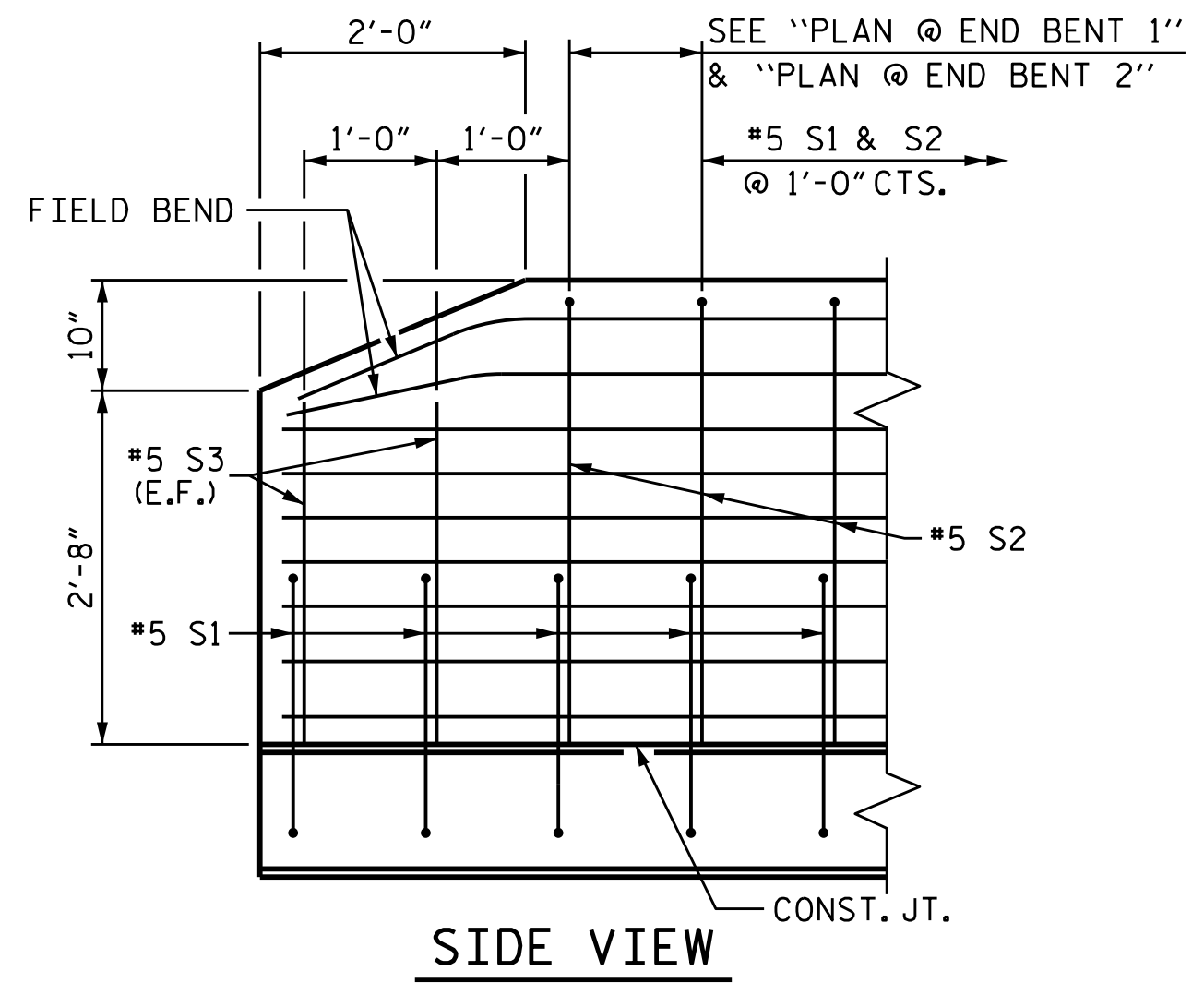

END OF RAIL DETAILS

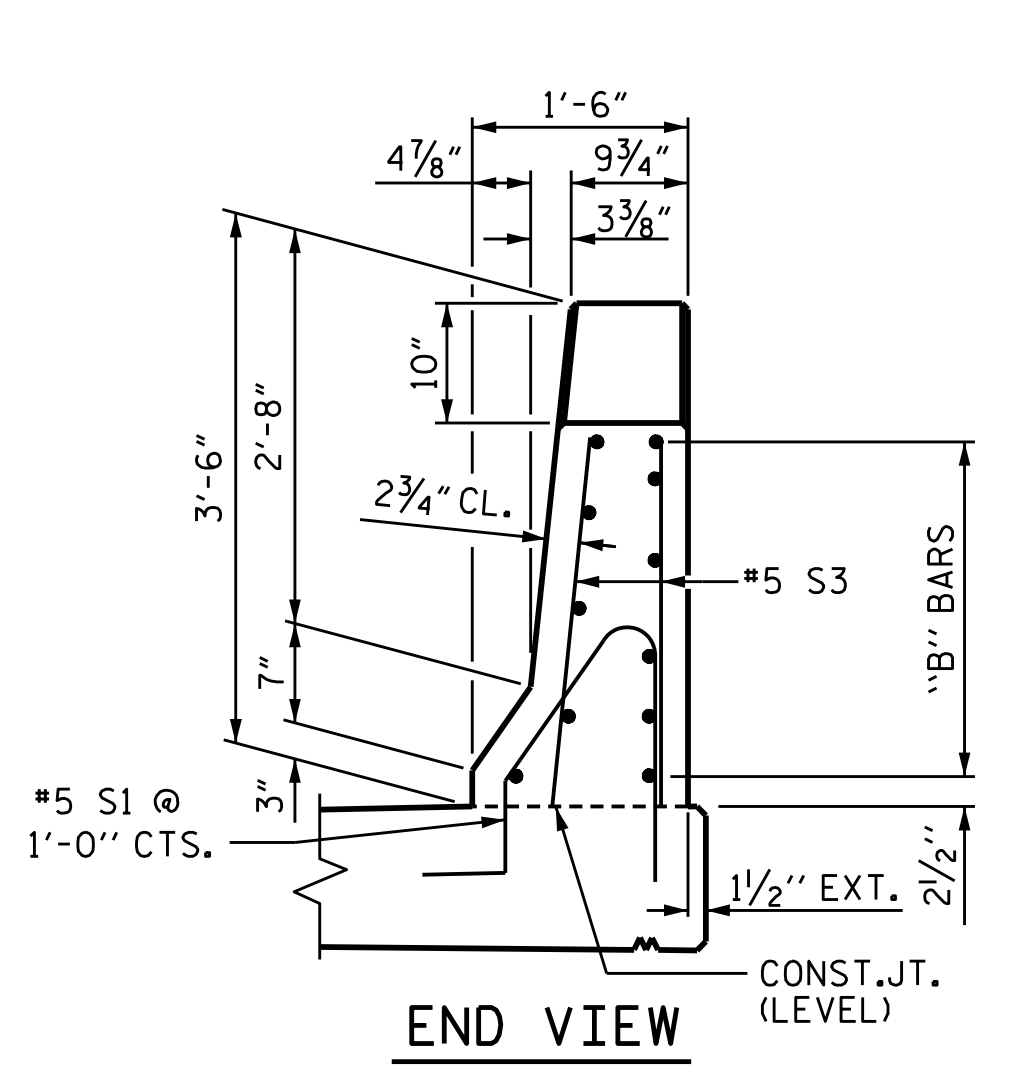
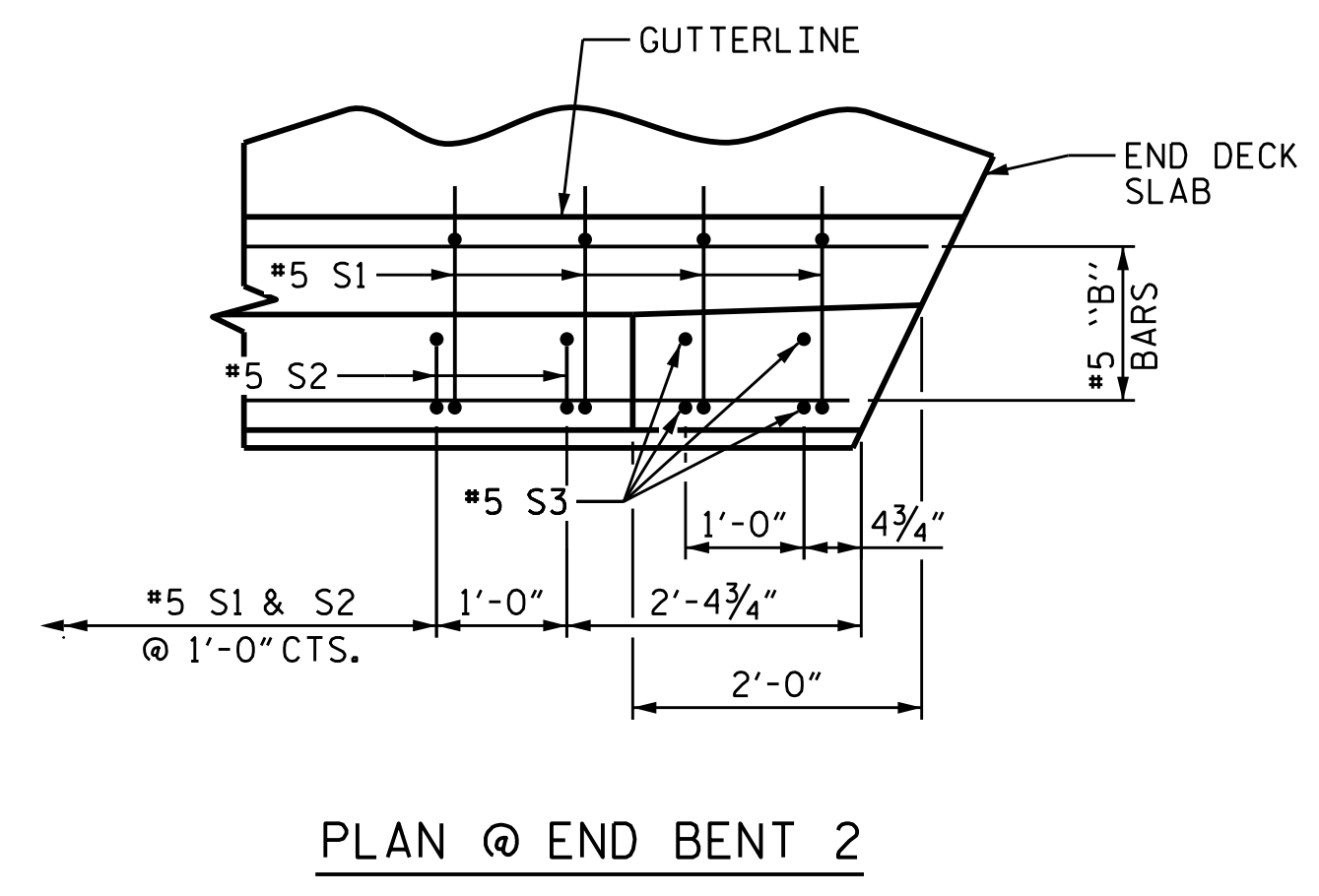
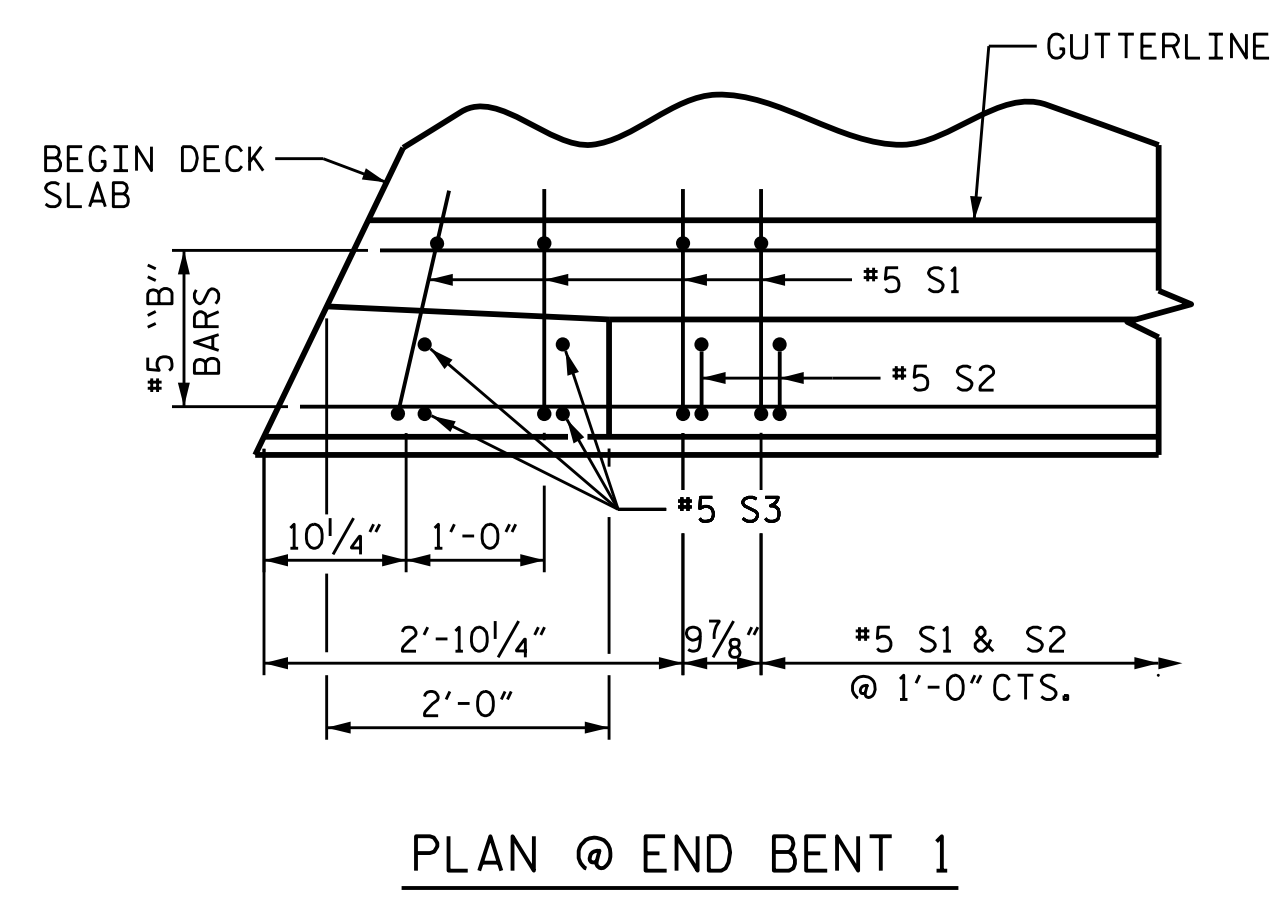
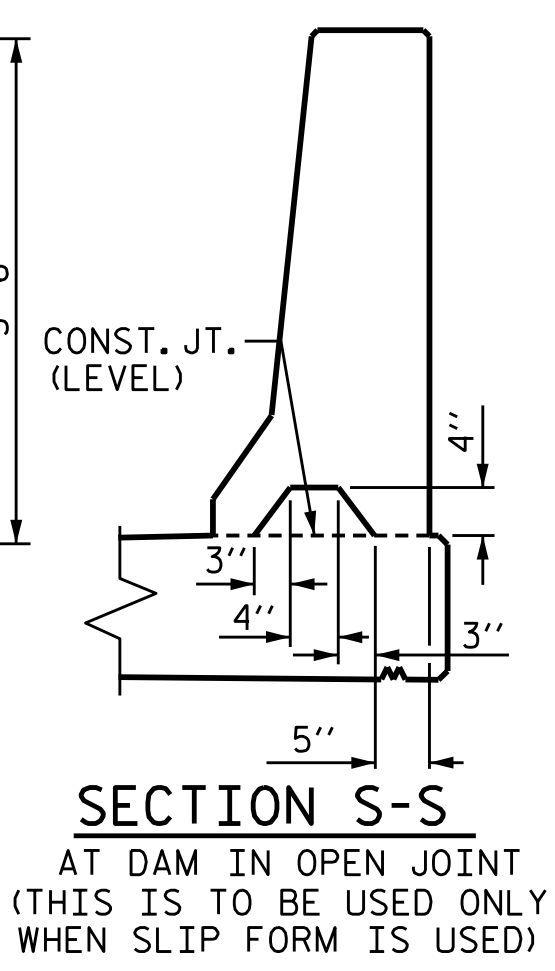
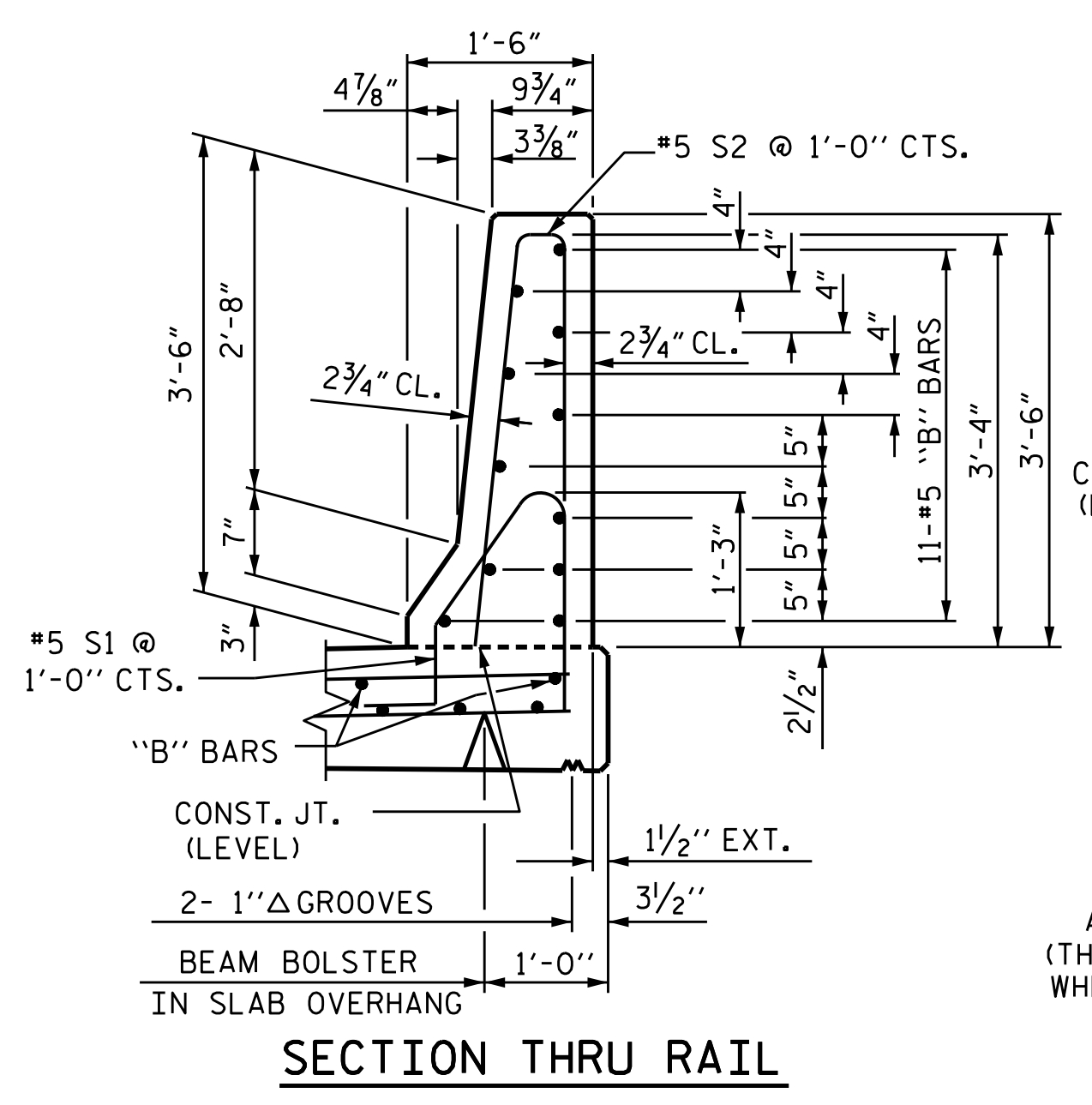

SECTION THRU RAIL

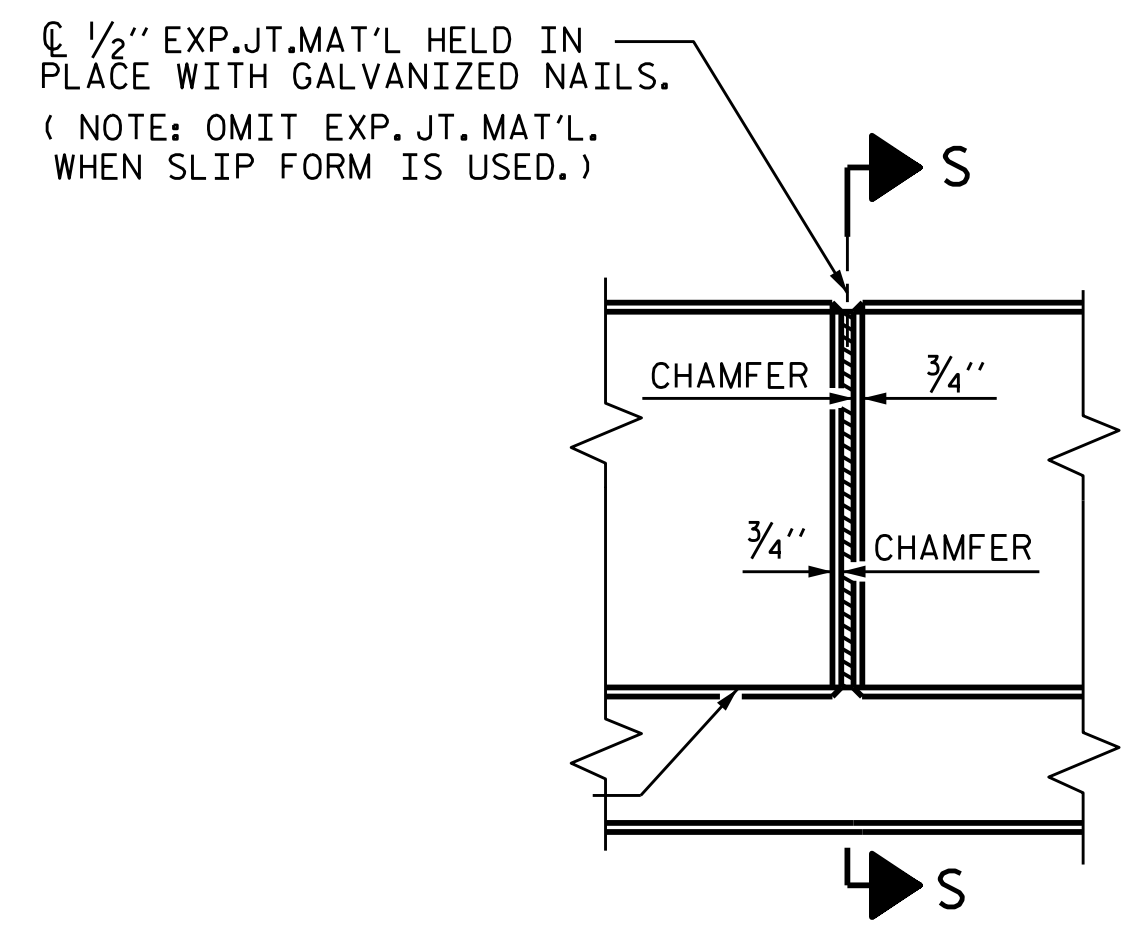

**ELEVATION AT EXPANSION JOINTS
BARRIER RAIL DETAILS**

NOTES

THE BARRIER RAIL IN EACH SPAN SHALL NOT BE CAST UNTIL ALL SLAB CONCRETE IN THAT SPAN HAS BEEN CAST AND HAS REACHED A MINIMUM COMPRESSIVE STRENGTH OF 3,000 PSI.

ALL REINFORCING STEEL IN BARRIER RAILS SHALL BE EPOXY COATED.

GROOVED CONTRACTION JOINTS, 1/2" IN DEPTH, SHALL BE TOOLED IN ALL EXPOSED FACES OF THE BARRIER RAIL AND IN ACCORDANCE WITH ARTICLE 825-10(B) OF THE STANDARD SPECIFICATIONS. THE CONTRACTION JOINT SHALL BE LOCATED AT EACH THIRD POINT BETWEEN BARRIER RAIL EXPANSION JOINTS. ONLY ONE CONTRACTION JOINT IS REQUIRED AT MIDPOINT OF BARRIER RAIL SEGMENTS LESS THAN 20 FEET IN LENGTH AND NO CONTRACTION JOINTS ARE REQUIRED FOR THOSE SEGMENTS LESS THAN 10 FEET IN LENGTH.

THE #5 S1 AND #5 S2 BARS MAY BE SHIFTED SLIGHTLY IN ORDER TO MAINTAIN A 2" MIN. CLEARANCE TO THE 1/2" EXPANSION JOINT MATERIAL IN PARAPET.

BILL OF MATERIAL

FOR CONCRETE BARRIER RAIL ONLY

BAR	NO.	SIZE	TYPE	LENGTH	WEIGHT
* B1	99	#5	STR	19'-7"	2022
* B2	22	#5	STR	8'-11"	205
* B3	22	#5	STR	11'-5"	262
* S1	213	#5	1	4'-6"	1000
* S2	209	#5	2	7'-0"	1526
* S3	8	#5	STR	2'-7"	22

* EPOXY COATED REINFORCING STEEL 5037 LBS.
CLASS AA CONCRETE 29.0 CU. YDS.
CONCRETE BARRIER RAIL 213.07 LIN. FT.

BAR TYPES

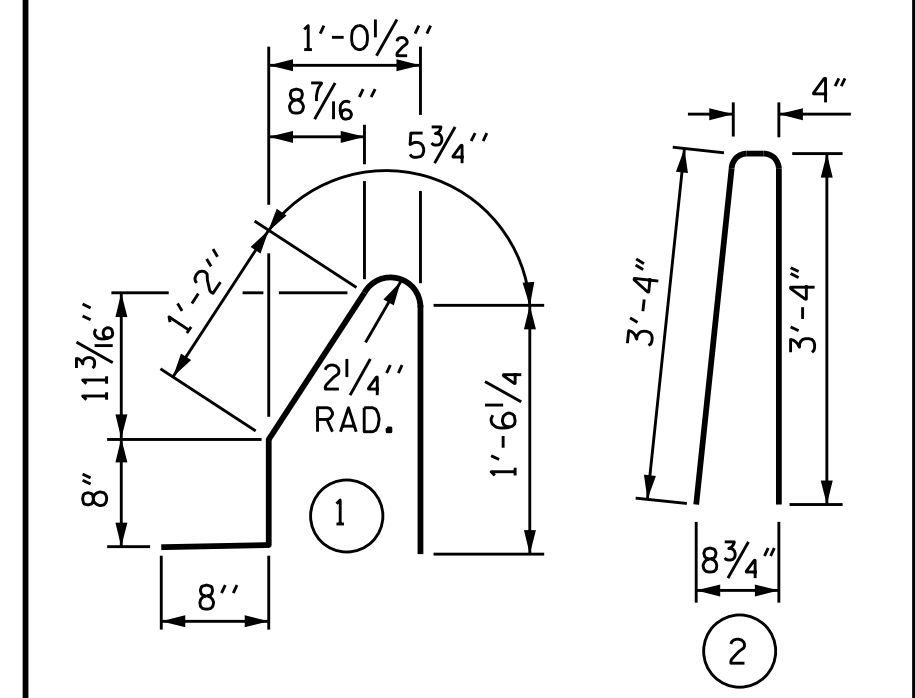

ALL BAR DIMENSIONS ARE OUT TO OUT

PROJECT NO. B-5717
GUILFORD COUNTY
STATION: 21+22.00 -L-

SHEET 2 OF 3

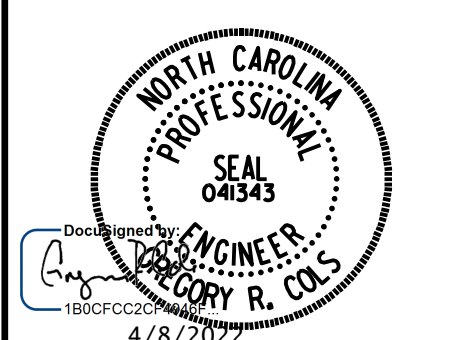

STATE OF NORTH CAROLINA
DEPARTMENT OF TRANSPORTATION
RALEIGH
STANDARD
CONCRETE BARRIER RAIL
(LEFT LANE)

REVISIONS						SHEET NO.	
NO.	BY:	DATE:	NO.	BY:	DATE:	S2-18	
1			3			TOTAL SHEETS 38	
2			4				

DOCUMENT NOT CONSIDERED FINAL UNLESS ALL SIGNATURES COMPLETED

ASSEMBLED BY : B.D. HODACK	DATE : 05/2021
CHECKED BY : S. NATARAJAN	DATE : 08/2021
DRAWN BY : ARB 5/87	REV. 7/12 MAA/GM
CHECKED BY : SJD 9/87	REV. 6/13 MAA/GM
	REV. 12/17 MAA/THC

STD. NO. CBR1