

TIP NO. B-5717	SHEET NO. PMP-3
APPROVED: <i>Timothy A. Klotz</i> SEAL 046210 ENGINEER TIMOTHY A. KLOTZ	
DATE: 4/25/2022	
SEAL	
<p style="text-align: center;">DOCUMENT NOT CONSIDERED FINAL UNLESS ALL SIGNATURES COMPLETED</p> <p>AECOM <small>NC FIRM LICENSE No. F-0342 5438 Wade Park Boulevard, Suite 200 Raleigh, NC 27607 1997-461-1100</small></p>	

- CURB RAMP LOCATIONS**
- ② -L- 24+80 +/- 59' LT (TYPE 1A)
 - ③ -L- 24+80 +/- 6' LT (M.I. CUT THROUGH)
 - ④ -L- 24+80 +/- 58' RT (TYPE 3)
 - ⑤ -L- 25+25 +/- 97' RT (TYPE 2)
 - ⑥ -L- 25+58 +/- 97' RT (TYPE 1)
 - ⑦ -L- 27+07 +/- 57' RT (TYPE 1)

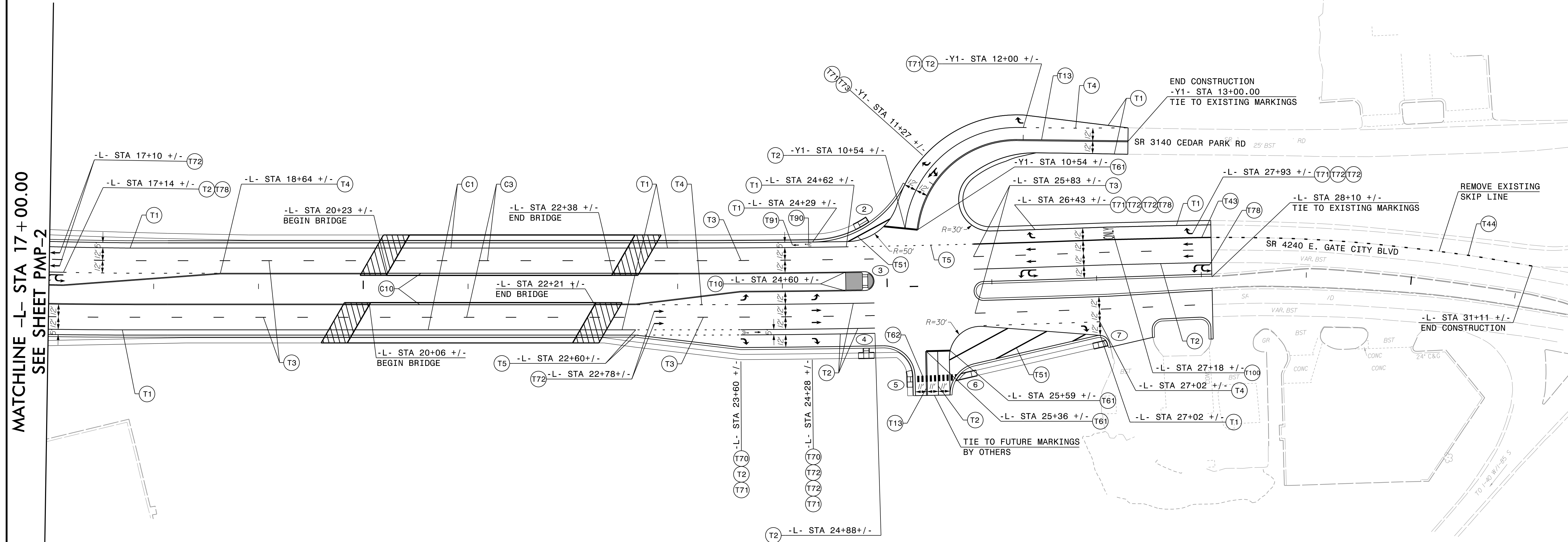
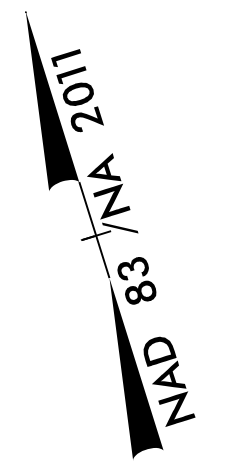

MATCHLINE -L- STA 17+00.00
SEE SHEET PMP-2

20

25

PAVEMENT MARKING DETAIL

3/7/2022
p:\aecom-na-pw-bentley.com\AECOM_DS21_NA_2020\Documents\60592827-NC001_SMU-B-5717\900-CAD_GIS\910-CAD\TO-NC001_TIP\Tranfig\PM\B5717_pmp_psh03.dgn
Tim.Klotz