

**This electronic collection of documents is provided  
for the convenience of the user  
and is Not a Certified Document –**

**The documents contained herein were originally issued  
and sealed by the individuals whose names and license  
numbers appear on each page, on the dates appearing  
with their signature on that page.**

**This file or an individual page  
shall not be considered a certified document.**

09/28/2019

TIP PROJECT: U-2519BA

STATE OF NORTH CAROLINA  
DIVISION OF HIGHWAYS

T.I.P. NO.	SHEET NO.
U-2519BA	UC-1

# UTILITY CONSTRUCTION PLANS CUMBERLAND COUNTY

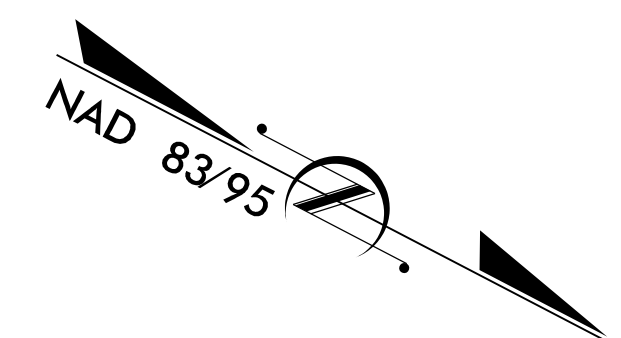

LOCATION: FAYETTEVILLE OUTER LOOP FROM SOUTH OF  
SR 1003 (CAMDEN ROAD) TO SOUTH OF SR 1104  
(STRICKLAND BRIDGE ROAD)

TYPE OF WORK: WATER AND SEWER LINE RELOCATION

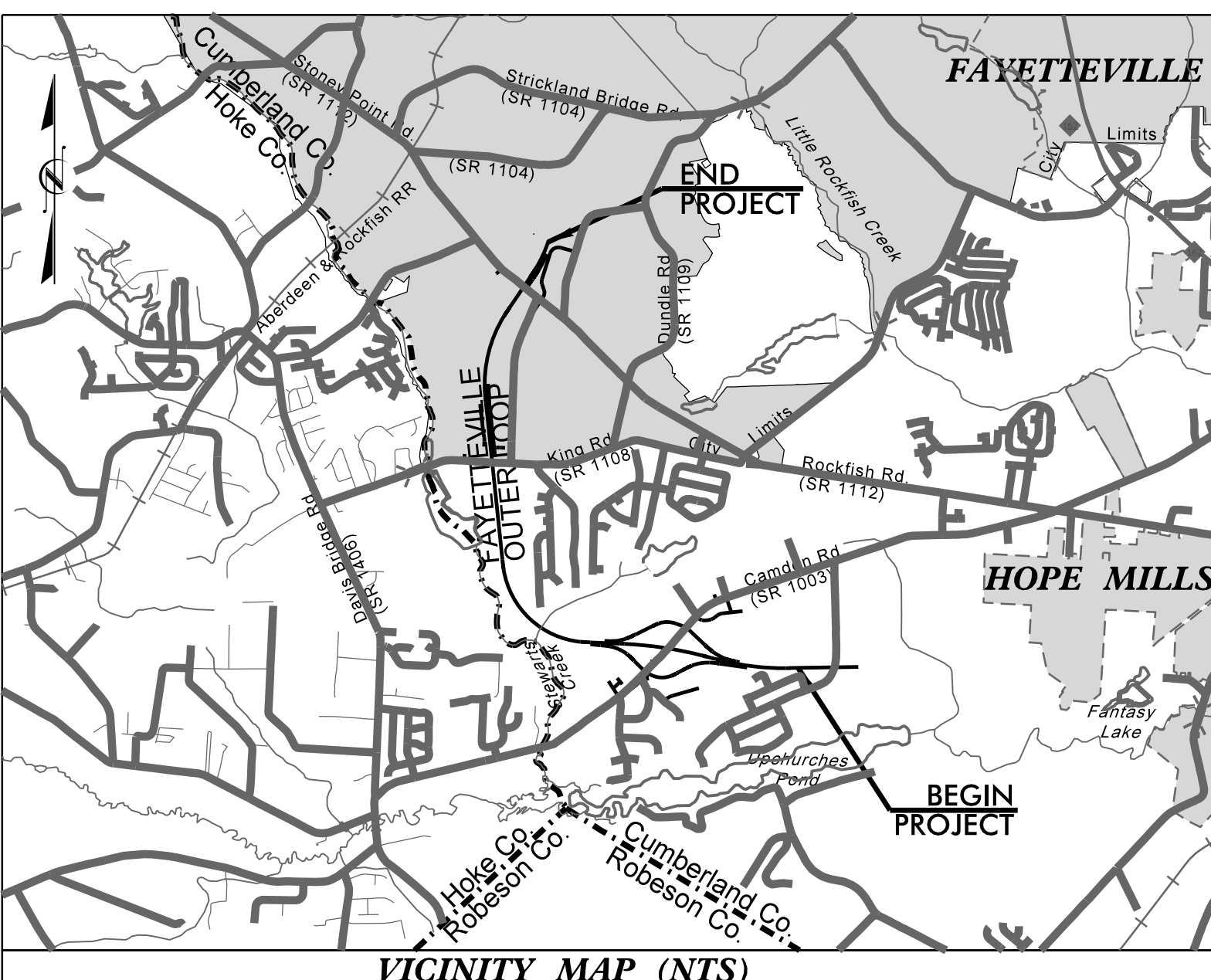

VICINITY MAP (NTS)

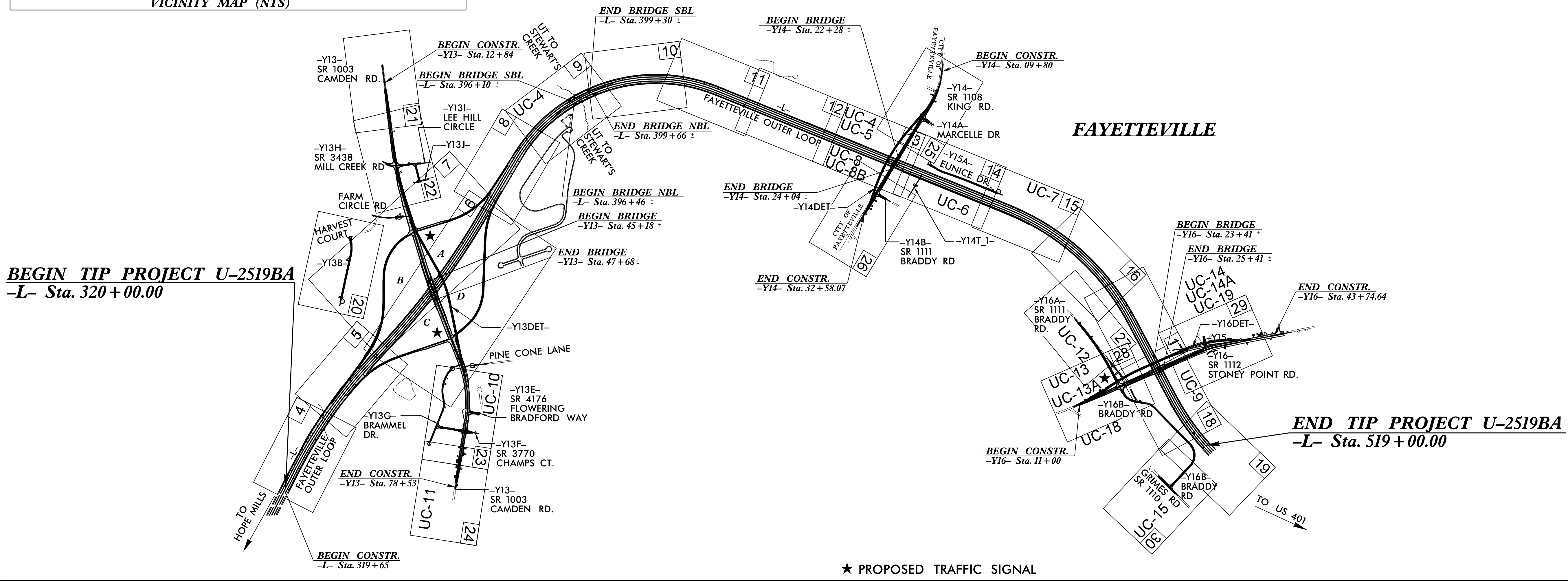

BEGIN TIP PROJECT U-2519BA  
-L- Sta. 320 + 00.00

END TIP PROJECT U-2519BA  
-L- Sta. 519 + 00.00

★ PROPOSED TRAFFIC SIGNAL

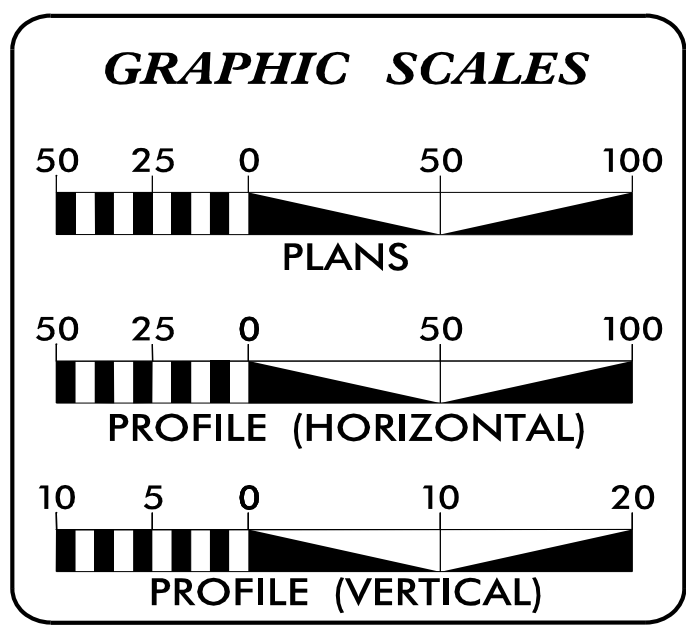

INDEX OF SHEETS	
SHEET NO.:	DESCRIPTION:
UC-1	TITLE SHEET
UC-2	UTILITY SYMBOLOGY
UC-3	NOTES
UC-3A THRU UC-3H	DETAILS
UC-4 THRU UC-20	UTILITY CONSTRUCTION PLAN & PROFILE SHEETS

WATER AND SEWER OWNERS ON PROJECT	
(A) WATER, FAYETTEVILLE PUBLIC WORKS COMMISSION (FAYPWC)	
(B) SEWER, FAYETTEVILLE PUBLIC WORKS COMMISSION (FAYPWC)	

PREPARED IN THE OFFICE OF  
CONSULTANT INFO

**Dewberry**  
2610 WYCLIFF ROAD, SUITE 410  
RALEIGH, NC 27607  
919.881.9939  
NCBELS: NO. F-0929

**WK DICKSON**  
community infrastructure consultants  
720 CORPORATE CENTER DRIVE  
RALEIGH, NORTH CAROLINA 27607  
(919) 782-0495 NCBEES #F-0374

TIMOTHY RITACCO, P.E. CONSULTANT CONTACT #1  
DUSTIN JAMES CONSULTANT CONTACT #2  
KATHRYN KNAPP, E.I. CONSULTANT CONTACT #3

SEAL

3/18/2022

**DIVISION OF HIGHWAYS UTILITIES UNIT**  
1555 MAIL SERVICES CENTER  
RALEIGH, NC 27699-1555  
PHONE (919) 707-6690  
FAX (919) 250-4151

NABIL HAMDAN UTILITIES REGIONAL ENGINEER  
KIFAH KAMIL UTILITIES ENGINEER  
KYLE PLEASANT UTILITIES AREA COORDINATOR  
DAYTON MARTIN UTILITIES COORDINATOR

01-MAR-2022 14:29  
C:\CAD\U2519BA\design\280\_00X\_U2519BA\_UT\_UC01\_TSH.dgn  
\$\$\$\$\$USERNAME\$\$\$\$\$

# STATE OF NORTH CAROLINA, DIVISION OF HIGHWAYS CONVENTIONAL PLAN SHEET SYMBOLS

Note: Not to Scale \*S.U.E. = Subsurface Utility Engineering

04/06/15

## BOUNDARIES AND PROPERTY:

State Line	-----
County Line	-----
Township Line	-----
City Line	-----
Reservation Line	-----
Property Line	-----
Existing Iron Pin	○ EIP
Property Corner	-----
Property Monument	□ ECM
Parcel/Sequence Number	①23
Existing Fence Line	-x-x-x-
Proposed Woven Wire Fence	○
Proposed Chain Link Fence	□
Proposed Barbed Wire Fence	◇
Existing Wetland Boundary	-WLB-
Proposed Wetland Boundary	WLB
Existing Endangered Animal Boundary	-EAB-
Existing Endangered Plant Boundary	-EPB-
Existing Historic Property Boundary	-HPB-
Known Contamination Area: Soil	☠ ☠
Potential Contamination Area: Soil	☠ ☠
Known Contamination Area: Water	☠ ☠
Potential Contamination Area: Water	☠ ☠
Contaminated Site: Known or Potential	☠ ☠

## BUILDINGS AND OTHER CULTURE:

Gas Pump Vent or U/G Tank Cap	○
Sign	○ S
Well	○ W
Small Mine	✕
Foundation	□
Area Outline	□
Cemetery	□
Building	□
School	□
Church	□
Dam	□

## HYDROLOGY:

Stream or Body of Water	-----
Hydro, Pool or Reservoir	-----
Jurisdictional Stream	-JS-
Buffer Zone 1	-BZ 1-
Buffer Zone 2	-BZ 2-
Flow Arrow	←
Disappearing Stream	→
Spring	○
Wetland	↓
Proposed Lateral, Tail, Head Ditch	-----
False Sump	▽

## RAILROADS:

Standard Gauge	-----
RR Signal Milepost	○ MILEPOST 35
Switch	□ SWITCH
RR Abandoned	-----
RR Dismantled	-----

## RIGHT OF WAY:

Baseline Control Point	◆
Existing Right of Way Marker	△
Existing Right of Way Line	-----
Proposed Right of Way Line	○ RW
Proposed Right of Way Line with Iron Pin and Cap Marker	○ RW ▲
Proposed Right of Way Line with Concrete or Granite RW Marker	▲ RW
Proposed Control of Access Line with Concrete C/A Marker	○ C/A
Existing Control of Access	○ C/A
Proposed Control of Access	○ C/A
Existing Easement Line	-E-
Proposed Temporary Construction Easement	E
Proposed Temporary Drainage Easement	TDE
Proposed Permanent Drainage Easement	PDE
Proposed Permanent Drainage / Utility Easement	DUE
Proposed Permanent Utility Easement	PUE
Proposed Temporary Utility Easement	TUE
Proposed Aerial Utility Easement	AUE
Proposed Permanent Easement with Iron Pin and Cap Marker	◆

## ROADS AND RELATED FEATURES:

Existing Edge of Pavement	-----
Existing Curb	-----
Proposed Slope Stakes Cut	-C-
Proposed Slope Stakes Fill	-F-
Proposed Curb Ramp	○ CR
Existing Metal Guardrail	T T T T
Proposed Guardrail	T T T T
Existing Cable Guiderail	□ □ □ □
Proposed Cable Guiderail	□ □ □ □
Equality Symbol	⊕
Pavement Removal	⊗

## VEGETATION:

Single Tree	☀
Single Shrub	☀
Hedge	~~~~~
Woods Line	~~~~~

Orchard	☀ ☀ ☀ ☀
Vineyard	□ Vineyard

## EXISTING STRUCTURES:

MAJOR:	
Bridge, Tunnel or Box Culvert	CONC
Bridge Wing Wall, Head Wall and End Wall	CONC WW
MINOR:	
Head and End Wall	CONC HW
Pipe Culvert	-----
Footbridge	-----
Drainage Box: Catch Basin, DI or JB	□ CB
Paved Ditch Gutter	-----
Storm Sewer Manhole	⊕
Storm Sewer	S

## UTILITIES:

POWER:	
Existing Power Pole	●
Proposed Power Pole	○
Existing Joint Use Pole	●
Proposed Joint Use Pole	○
Power Manhole	⊕
Power Line Tower	⊗
Power Transformer	⊗
U/G Power Cable Hand Hole	○
H-Frame Pole	●
U/G Power Line LOS B (S.U.E.*)	-----P-----
U/G Power Line LOS C (S.U.E.*)	-----P-----
U/G Power Line LOS D (S.U.E.*)	-----P-----

## TELEPHONE:

Existing Telephone Pole	●
Proposed Telephone Pole	○
Telephone Manhole	⊕
Telephone Pedestal	⊕
Telephone Cell Tower	⊕
U/G Telephone Cable Hand Hole	○
U/G Telephone Cable LOS B (S.U.E.*)	-----T-----
U/G Telephone Cable LOS C (S.U.E.*)	-----T-----
U/G Telephone Cable LOS D (S.U.E.*)	-----T-----
U/G Telephone Conduit LOS B (S.U.E.*)	-----TC-----
U/G Telephone Conduit LOS C (S.U.E.*)	-----TC-----
U/G Telephone Conduit LOS D (S.U.E.*)	-----TC-----
U/G Fiber Optics Cable LOS B (S.U.E.*)	-----TFD-----
U/G Fiber Optics Cable LOS C (S.U.E.*)	-----TFD-----
U/G Fiber Optics Cable LOS D (S.U.E.*)	-----TFD-----

## WATER:

Water Manhole	⊕
Water Meter	○
Water Valve	⊗
Water Hydrant	⊕
U/G Water Line LOS B (S.U.E.*)	-----W-----
U/G Water Line LOS C (S.U.E.*)	-----W-----
U/G Water Line LOS D (S.U.E.*)	-----W-----
Above Ground Water Line	A/G Water

## TV:

TV Pedestal	⊕
TV Tower	⊗
U/G TV Cable Hand Hole	○
U/G TV Cable LOS B (S.U.E.*)	-----TV-----
U/G TV Cable LOS C (S.U.E.*)	-----TV-----
U/G TV Cable LOS D (S.U.E.*)	-----TV-----
U/G Fiber Optic Cable LOS B (S.U.E.*)	-----TV FO-----
U/G Fiber Optic Cable LOS C (S.U.E.*)	-----TV FO-----
U/G Fiber Optic Cable LOS D (S.U.E.*)	-----TV FO-----

## GAS:

Gas Valve	◇
Gas Meter	⊕
U/G Gas Line LOS B (S.U.E.*)	-----G-----
U/G Gas Line LOS C (S.U.E.*)	-----G-----
U/G Gas Line LOS D (S.U.E.*)	-----G-----
Above Ground Gas Line	A/G Gas

## SANITARY SEWER:

Sanitary Sewer Manhole	⊕
Sanitary Sewer Cleanout	⊕
U/G Sanitary Sewer Line	SS
Above Ground Sanitary Sewer	A/G Sanitary Sewer
SS Forced Main Line LOS B (S.U.E.*)	-----FSS-----
SS Forced Main Line LOS C (S.U.E.*)	-----FSS-----
SS Forced Main Line LOS D (S.U.E.*)	-----FSS-----

## MISCELLANEOUS:

Utility Pole	●
Utility Pole with Base	□
Utility Located Object	○
Utility Traffic Signal Box	⊕
Utility Unknown U/G Line LOS B (S.U.E.*)	-----TU/L-----
U/G Tank; Water, Gas, Oil	□
Underground Storage Tank, Approx. Loc.	UST
A/G Tank; Water, Gas, Oil	□
Geoenvironmental Boring	⊕
U/G Test Hole LOS A (S.U.E.*)	⊕
Abandoned According to Utility Records	AATUR
End of Information	E.O.I.

5/14/22

### GENERAL NOTES

1. THE CONTRACTOR SHALL NOTIFY CUMBERLAND COUNTY, NCDOT, FAYETTEVILLE PUBLIC WORKS COMMISSION, AND NC DEMLR LAND QUALITYSECTION TWO WEEKS PRIOR TO THE BEGINNING OF CONSTRUCTION.
2. THE CONTRACTOR SHALL HAVE A COMPLETE SET OF CONTRACT DOCUMENTS AS WELL AS ALL EASEMENTS, THE NCDOT ENCROACHMENT AGREEMENT, NCDOT DRIVEWAY PERMITS, NC DEMLR SEDIMENTATION AND EROSION CONTROL PERMIT, AND FAYETTEVILLE PUBLIC WORKS COMMISSION PERMITS ON THE JOB SITE AT ALL TIMES.
3. CONSTRUCTION AND MATERIAL SPECIFICATIONS SHALL CONFORM TO FAYETTEVILLE PUBLIC WORKS COMMISSION STANDARDS AND NCDOT STANDARD SPECIFICATIONS, LATEST EDITION.
4. STATIONING ON DRAWINGS IS SHOWN FOR REFERENCE ONLY AND MAY NOT REPRESENT EXACT LENGTHS.
5. ALL CONCRETE SHALL BE 3,000 PSI STRENGTH (28 DAY), UNLESS OTHERWISE NOTED.
6. THE CONTRACTOR IS RESPONSIBLE FOR ALL LAYOUT WORK REQUIRED TO PROPERLY CONSTRUCT THE WORK.
7. CONTRACTOR SHALL MAKE EVERY EFFORT TO SAVE PROPERTY IRONS, MONUMENTS, OTHER PERMANENT POINTS AND LINES OF REFERENCE AND CONSTRUCTION STAKES. PROPERTY IRONS, MONUMENTS, AND OTHER PERMANENT POINTS OF REFERENCE DAMAGED OR DESTROYED BY THE CONTRACTOR SHALL BE REPLACED BY A REGISTERED LAND SURVEYOR AT THE CONTRACTOR'S EXPENSE.
8. THE UNDERGROUND UTILITIES INDICATED ON THE PLANS HAVE BEEN TAKEN FROM INFORMATION MADE AVAILABLE FROM THE VARIOUS UTILITY OWNERS. THIS INFORMATION IS NOT INCLUSIVE OF ALL EXISTING UNDERGROUND UTILITIES. THE CONTRACTOR IS ADVISED THAT ADDITIONAL UNDERGROUND UTILITIES MAY EXIST WHICH ARE NOT SHOWN ON THE UTILITY INFORMATION SHEET. BE ADVISED THAT THE UNDERGROUND UTILITIES AND CABLES COULD CONFLICT WITH THE WATER AND SEWER MAIN CONSTRUCTION. ALL REALIGNMENTS SHALL BE APPROVED BY THE OWNER PRIOR TO CONSTRUCTION.
9. CONTRACTOR SHALL MINIMIZE PLACEMENT OF EXCAVATION MATERIAL ON ROAD DURING CONSTRUCTION. ALL ROADS SHALL BE CLEANED DAILY.
10. CONTRACTOR SHALL INSTALL MEASURES AS NECESSARY DURING CONSTRUCTION FOR SEDIMENTATION AND EROSION CONTROL.
11. CONTRACTOR SHALL COORDINATE WITH PWC FOR ANY DISRUPTIONS OF WATER SERVICE. CONTRACTOR SHALL BE RESPONSIBLE FOR THE RECONNECTING OF DISTURBED UTILITY SERVICES ENCOUNTERED WITHIN 8 HOURS OF INTERRUPTED SERVICE. CONTRACTOR SHALL NOTIFY USERS 24 HOURS PRIOR TO POSSIBLE INTERRUPTIONS OF SERVICE.
12. WATER AND SEWER MAINS SHALL HAVE 36" MINIMUM COVER. GREATER DEPTHS MAY BE REQUIRED TO AVOID CONFLICTS WITH CULVERT CROSSINGS, UTILITIES, AND OTHER STRUCTURES.
13. THE CONTRACTOR SHALL PROVIDE THRUST BLOCKING OR MECHANICALLY RESTRAINED JOINTS AT BENDS, TEES, AND PLUGS PER THE DETAILS SHOWN ON THE DRAWINGS.
14. ALL FITTINGS ARE NOT SHOWN ON THE DRAWINGS, THE CONTRACTOR SHALL BE RESPONSIBLE FOR PROVIDING AND INSTALLING ALL FITTINGS NECESSARY TO COMPLETE THE WORK.
15. THE CONTRACTOR SHALL RESEED THE DISTURBED AREAS WITH THE EXISTING TYPE OF GRASS. THE CONTRACTOR SHALL CONFIRM THE TYPE OF GRASS WITH THE ADJACENT PROPERTY OWNER. IN AREAS WHERE THE TYPE OF GRASS IS UNKNOWN, THE SEED SCHEDULE SHALL BE USED.

16. THE CONTRACTOR SHALL RESTORE THE DISTURBED AREA TO THE EXISTING GRADE UNLESS SHOWN OTHERWISE ON THE DRAWINGS.

17. THE CONTRACTOR SHALL REPAIR ALL DRIVEWAYS AND DRIVEWAY CULVERTS PAVED OR UNPAVED, TO EXISTING OR BETTER CONDITIONS IF DISTURBED DURING CONSTRUCTION. ACCESS TO EACH RESIDENCE AND BUSINESS SHALL BE MAINTAINED AT ALL TIMES. THE CONTRACTOR SHALL REPAIR DRIVEWAYS AND DRIVEWAY CULVERTS WITHIN ONE WEEK OF DISTURBANCE.

18. FOR ALL DRIVEWAYS, BOTH PUBLIC OR PRIVATE, THE CONTRACTOR SHALL USE LIKE GRAVEL OR STONE FOR REPAIR AND/OR REPLACEMENT.

19. THE CONTRACTOR SHALL BE RESPONSIBLE FOR RELOCATION OF EXISTING UTILITIES IF REQUIRED DURING INSTALLATION OF NEW WORK. THERE SHALL BE NO ADDITIONAL OR SEPARATE PAY ITEM FOR THIS WORK UNLESS SPECIFICALLY CALLED OUT IN THE BID FORM.

20. CONTRACTOR SHALL RESTORE/REPLACE ALL SIGNS, MAILBOXES, ETC. ENCOUNTERED TO OWNER'S SATISFACTION WITHIN 4 HOURS OF DISTURBANCE.

21. ALL STORM WATER CULVERTS MAY NOT BE SHOWN ON THE DRAWINGS. LOCATION AND LENGTH OF SHOWN CULVERTS ARE APPROXIMATE. ACTUAL LOCATION, LENGTH, AND DIAMETER MAY VARY.

ALIGNMENT	COMMON NAME
Y13	SR 1003 CAMDEN ROAD
Y13B	SR 3437 HARVEST COURT
Y13E	FLOWERING BRADFORD WAY
Y13F	CHAMPS COURT
Y13G	TIE-IN TO BAMMEL DR
Y13H	SR 3438 MILL CREEK ROAD
Y13I	LEE HILL CIRCLE
Y13J	LEE HILL CIRCLE
Y13T_1	LEE HILL CIRCLE
Y13RPA	Y13 RAMP A
Y13RPB	Y13 RAMP B
713RPC	Y13 RAMP C
Y13RPD	Y13 RAMP D
Y13CUL_1	SR 3303 FARM CIRCLE ROAD
Y13CUL_2	BAMMEL DRIVE
Y13CUL_3	PINE CONE LANE
Y14	SR 1108 KING ROAD
Y14A	MARCELLE DRIVE
Y14B	SR 1111 BRADY ROAD
Y14T_1	EUNICE DRIVE
Y15	AMOUR DRIVE
Y15A	ELMORAY ROAD (NEW ROAD)
Y16A	SR 1111 BRADY ROAD
Y16B	SR 1111 BRADY ROAD
Y16C	SR 1110 GRIMES ROAD



255 WYOMING ROAD  
SUITE 110  
FAYETTEVILLE, NC 28404  
PHONE: 910.881.8889  
NC COUN. #2602

PROJECT REFERENCE NO.	SHEET NO.
<b>U-2519BA</b>	<b>UC-2A</b>
DESIGNED BY: DJ	
DRAWN BY: DJ	
CHECKED BY: TR	
APPROVED BY: TR	
REVISED:	
	3/24/2022
	UTILITY CONSTRUCTION PLANS ONLY

## UTILITY CONSTRUCTION

### STANDARD ABBREVIATIONS

DESCRIPTION	ABBREVIATION
MAXIMUM	MAX. MAX.
MINIMUM	MIN. MIN.
TYPICAL	TYP. TYP.
EDGE OF PAVEMENT	EOP, E.O.P.
RIGHT-OF-WAY	R/W
CORRUGATED METAL PIPE	CMP
REINFORCED CONCRETE PIPE	RCP
EXISTING	EX.
NORTH CAROLINA	NC, N.C.
NORTH CAROLINA DEPARTMENT OF TRANSPORTATION	NCDOT
DUCTILE IRON PIPE	DIP, D.I.P.
STATE ROAD	SR, S.R.
STAINLESS STEEL	S.S.
MAINTAINED LIMITS	ML, M.L.
POLYVINYL CHLORIDE	PVC, P.V.C.
BELOW LAND SURFACE	BLS

### NOTE:

1. THE STANDARD LEGEND AND ABBREVIATIONS SHOWN ON THIS SHEET ARE FOR GENERAL USE THROUGHOUT THESE DRAWINGS.

### STANDARD LEGEND

DESCRIPTION	EXISTING	PROPOSED
WATER LINE	— W ——— W —	— 10" WL —
SEWER LINE	— FSS ——— FSS —	— 8" FSS —
SILT FENCE		-----
RIGHT-OF-WAY (OR PROPERTY LINE)	— (R/W) —	
GRAVEL DRIVE	—————	
WATTLE		⊞⊞⊞
LIMITS OF DISTURBANCE		—————
PROPERTY LINE	-----	



CONTRACTOR IS RESPONSIBLE FOR THE LOCATION OF ALL EXISTING UTILITIES LOCATED WITHIN PROJECT AREA. CALL NORTH CAROLINA 811 AT 811 OR 1-800-632-4949

21-MAR-2022 15:07  
\\CAD\CAD\C\_C\Utilities\Engineering\UC\Proj\280\_005\_U2519BA\_UT\_NOTES\_02\_PSH.dgn

5/14/99

# UTILITY CONSTRUCTION

## GENERAL NOTES:

1. THE PROPOSED UTILITY CONSTRUCTION SHALL MEET THE APPLICABLE REQUIREMENTS OF THE NC DEPARTMENT OF TRANSPORTATION'S "STANDARD SPECIFICATIONS FOR ROADS AND STRUCTURES" DATED JANUARY 2018 AND THE PROJECT SPECIAL PROVISIONS OR FAYETTEVILLE PUBLIC WORKS COMMISSION STANDARDS.
2. THE EXISTING UTILITIES BELONG TO FAYETTEVILLE PUBLIC WORKS COMMISSION (FAYPWC) . CONTACT IS ALLAN RIDDLE, PE AND CAN BE REACHED AT (910) 223-4785.
3. ALL WATER LINES TO BE INSTALLED IN ACCORDANCE WITH THE FAYETTEVILLE PUBLIC WORKS COMMISSION STANDARDS.
4. THE UTILITY OWNER OWNS THE EXISTING UTILITY FACILITIES AND WILL OWN THE NEW UTILITY FACILITIES AFTER ACCEPTANCE BY THE DEPARTMENT. THE DEPARTMENT OWNS THE CONSTRUCTION CONTRACT AND HAS ADMINISTRATIVE AUTHORITY. COMMUNICATIONS AND DECISIONS BETWEEN THE CONTRACTOR AND UTILITY OWNER ARE NOT BINDING UPON THE DEPARTMENT OR THIS CONTRACT UNLESS AUTHORIZED BY THE ENGINEER. AGREEMENTS BETWEEN THE UTILITY OWNER AND CONTRACTOR FOR THE WORK THAT IS NOT PART OF THIS CONTRACT OR IS SECONDARY TO THIS CONTRACT ARE ALLOWED, BUT ARE NOT BINDING UPON THE DEPARTMENT.
5. PROVIDE ACCESS FOR THE DEPARTMENT PERSONNEL AND THE OWNER'S REPRESENTATIVES TO ALL PHASES OF CONSTRUCTION. NOTIFY DEPARTMENT PERSONNEL AND THE UTILITY OWNER TWO WEEKS PRIOR TO COMMENCEMENT OF ANY WORK AND ONE WEEK PRIOR TO SERVICE INTERRUPTION. KEEP UTILITY OWNERS' REPRESENTATIVES INFORMED OF WORK PROGRESS AND PROVIDE OPPORTUNITY FOR INSPECTION OF CONSTRUCTION AND TESTING.

6. THE PLANS DEPICT THE BEST AVAILABLE INFORMATION FOR THE LOCATION, SIZE, AND TYPE OF MATERIAL FOR ALL EXISTING UTILITIES. MAKE INVESTIGATIONS FOR DETERMINING THE EXACT LOCATION, SIZE, AND TYPE MATERIAL OF THE EXISTING FACILITIES AS NECESSARY FOR THE CONSTRUCTION OF THE PROPOSED UTILITIES AND FOR AVOIDING DAMAGE TO EXISTING FACILITIES. REPAIR ANY DAMAGE INCURRED TO EXISTING FACILITIES TO THE ORIGINAL OR BETTER CONDITION AT NO ADDITIONAL COST TO THE DEPARTMENT.
7. MAKE FINAL CONNECTIONS OF THE NEW WORK TO THE EXISTING SYSTEM WHERE INDICATED ON THE PLANS, AS REQUIRED TO FIT THE ACTUAL CONDITIONS, OR AS DIRECTED.
8. MAKE CONNECTIONS BETWEEN EXISTING AND PROPOSED UTILITIES AT TIMES MOST CONVENIENT TO THE PUBLIC, WITHOUT ENDANGERING THE UTILITY SERVICE, AND IN ACCORDANCE WITH THE UTILITY OWNER'S REQUIREMENTS. MAKE CONNECTIONS ON WEEKENDS, AT NIGHT, AND ON HOLIDAYS IF NECESSARY.
9. ALL UTILITY MATERIALS SHALL BE APPROVED PRIOR TO DELIVERY TO THE PROJECT. SEE 1500-7, " SUBMITTALS AND RECORDS" IN SECTION 1500 OF THE STANDARD SPECIFICATIONS.

## PROJECT SPECIFIC NOTES:

1. CONTRACTOR'S ATTENTION IS DIRECTED TO SECTIONS 102, 107, AND 1550 OF THE STANDARD SPECIFICATIONS CONCERNING TRENCHLESS INSTALLATION. IT IS CONTRACTOR'S RESPONSIBILITY TO HAVE BORE DESIGNED AND SEALED BY A LICENSED NORTH CAROLINA PROFESSIONAL ENGINEER. NO DAMAGE IS ALLOWED TO RIVER, WETLANDS, OR BUFFER ZONES.

PROJECT REFERENCE NO.	SHEET NO.
<b>U-2519BA</b>	<b>UC-3</b>
DESIGNED BY: DJ	
DRAWN BY: DJ	
CHECKED BY: TR	
APPROVED BY: TR	
REVISED:	
NORTH CAROLINA DEPARTMENT OF TRANSPORTATION UTILITIES ENGINEERING SEC. PHONE: (919) 707-6690 FAX: (919) 250-4151	
UTILITY CONSTRUCTION PLANS ONLY	

## UTILITY CONSTRUCTION

21-MAR-2022 15:29  
C:\Users\jritacco\OneDrive\Engineering\UC\Proj\2519BA\UT\_NOTES\_UC03.PSH.dgn

# PROJECT TYPICAL DETAILS



2550 WOODCREEK ROAD  
FAYETTEVILLE, NC 28404  
PHONE: 910.881.8889  
NC COLA NO. 24802

PROJECT REFERENCE NO.	SHEET NO.
U-2519BA	UC-3B
DESIGNED BY: DJ	
DRAWN BY: DJ	
CHECKED BY: TR	
APPROVED BY: TR	
REVISED:	3/24/2022
UTILITY CONSTRUCTION PLANS ONLY	

## UTILITY CONSTRUCTION

NOTE:  
ANY REFERENCE TO FAYPWC PROJECT COORDINATOR, PWC COORDINATOR OR FAYPWC (FAYETTEVILLE PUBLIC WORKS COMMISSION) SHALL BE INTERPRETTED AS A REFERENCE TO THE ENGINEER.

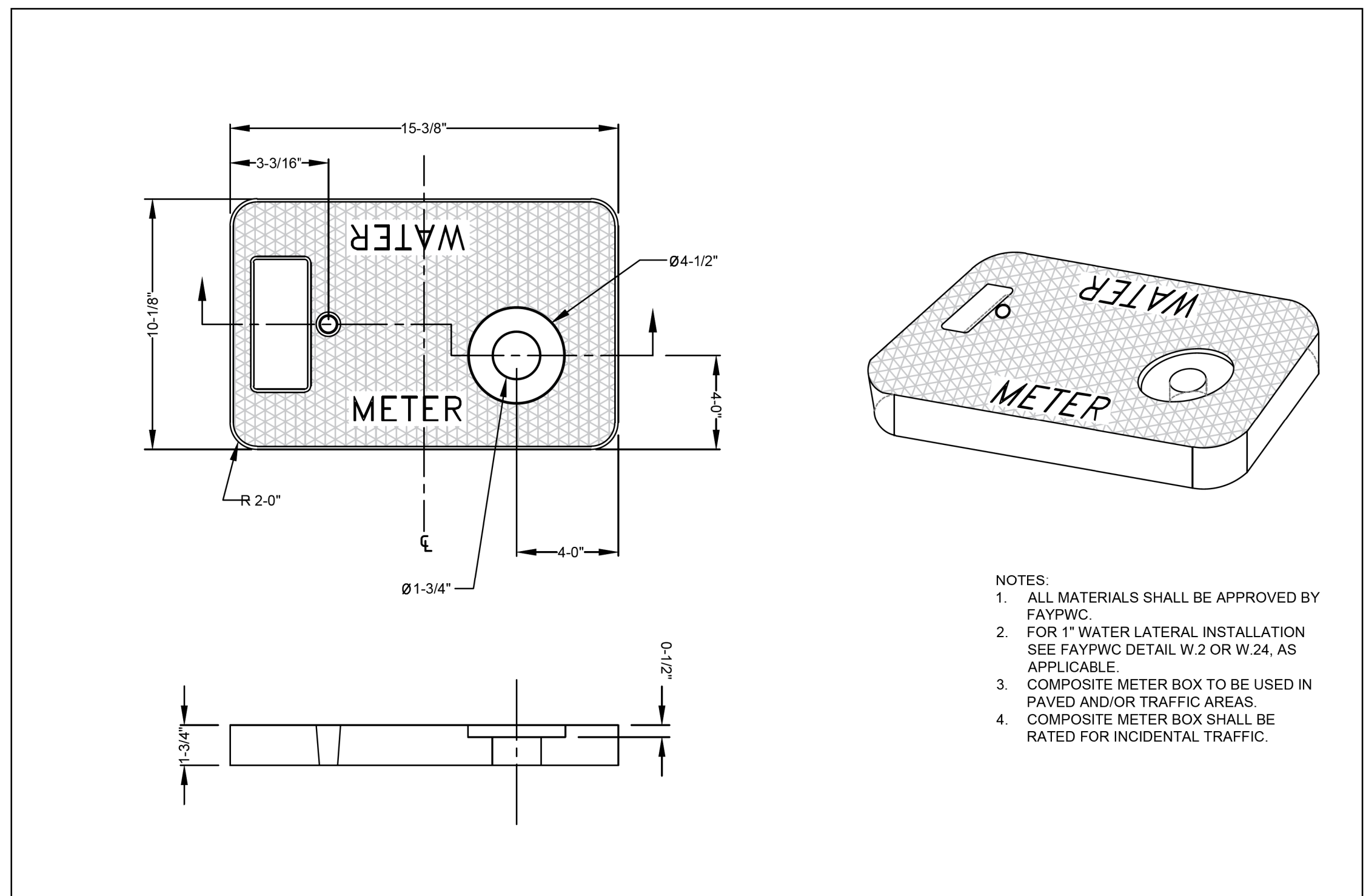

- NOTES:
1. ALL MATERIALS SHALL BE APPROVED BY FAYPWC.
  2. FOR 1" WATER LATERAL INSTALLATION SEE FAYPWC DETAIL W.2 OR W.24, AS APPLICABLE.
  3. COMPOSITE METER BOX TO BE USED IN PAVED AND/OR TRAFFIC AREAS.
  4. COMPOSITE METER BOX SHALL BE RATED FOR INCIDENTAL TRAFFIC.

1-INCH COMPOSITE METER BOX & COVER N.T.S.		FAYETTEVILLE PUBLIC WORKS COMMISSION FAYETTEVILLE, N.C.			NO.	DATE	REVISION
SHEET NO. 1 OF 2	DWG. NO. W.4B DATE: JAN. 01, 2022	DWG. BY: FAYPWC APPROVED BY: M.M.M.	WATER RESOURCES DEPARTMENT		1	03/10	CHANGED BOX & LID DIMENSIONS
W4B-METERBOX-LID.dwg							

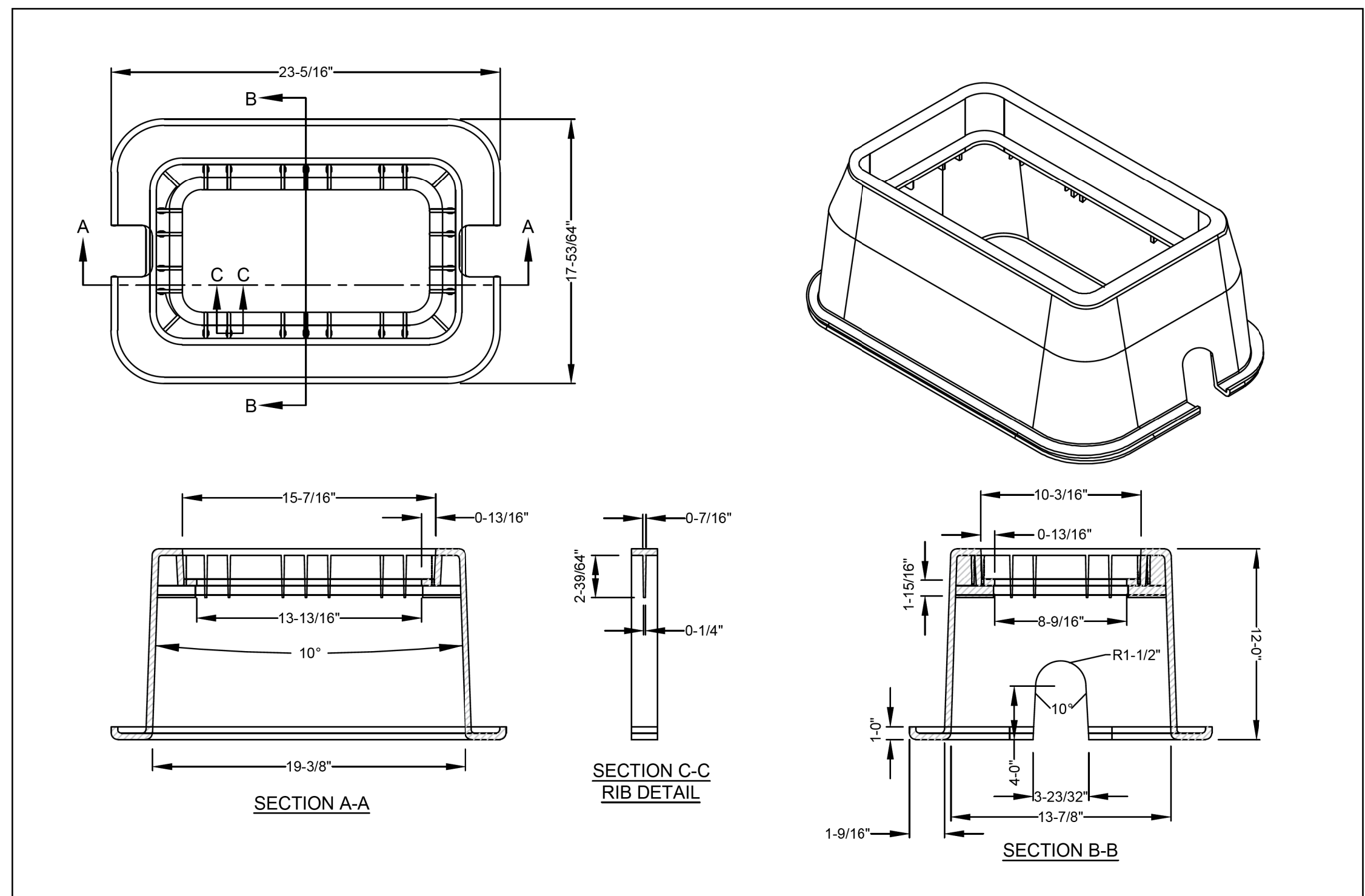

1-INCH COMPOSITE METER BOX & COVER N.T.S.		FAYETTEVILLE PUBLIC WORKS COMMISSION FAYETTEVILLE, N.C.			NO.	DATE	REVISION
SHEET NO. 2 OF 2	DWG. NO. W.4B DATE: JAN. 01, 2022	DWG. BY: FAYPWC APPROVED BY: M.M.M.	WATER RESOURCES DEPARTMENT		1	12/15	REPLACED CI BOX WITH COMPOSITE BOX
W4B-METERBOX-LID.dwg							

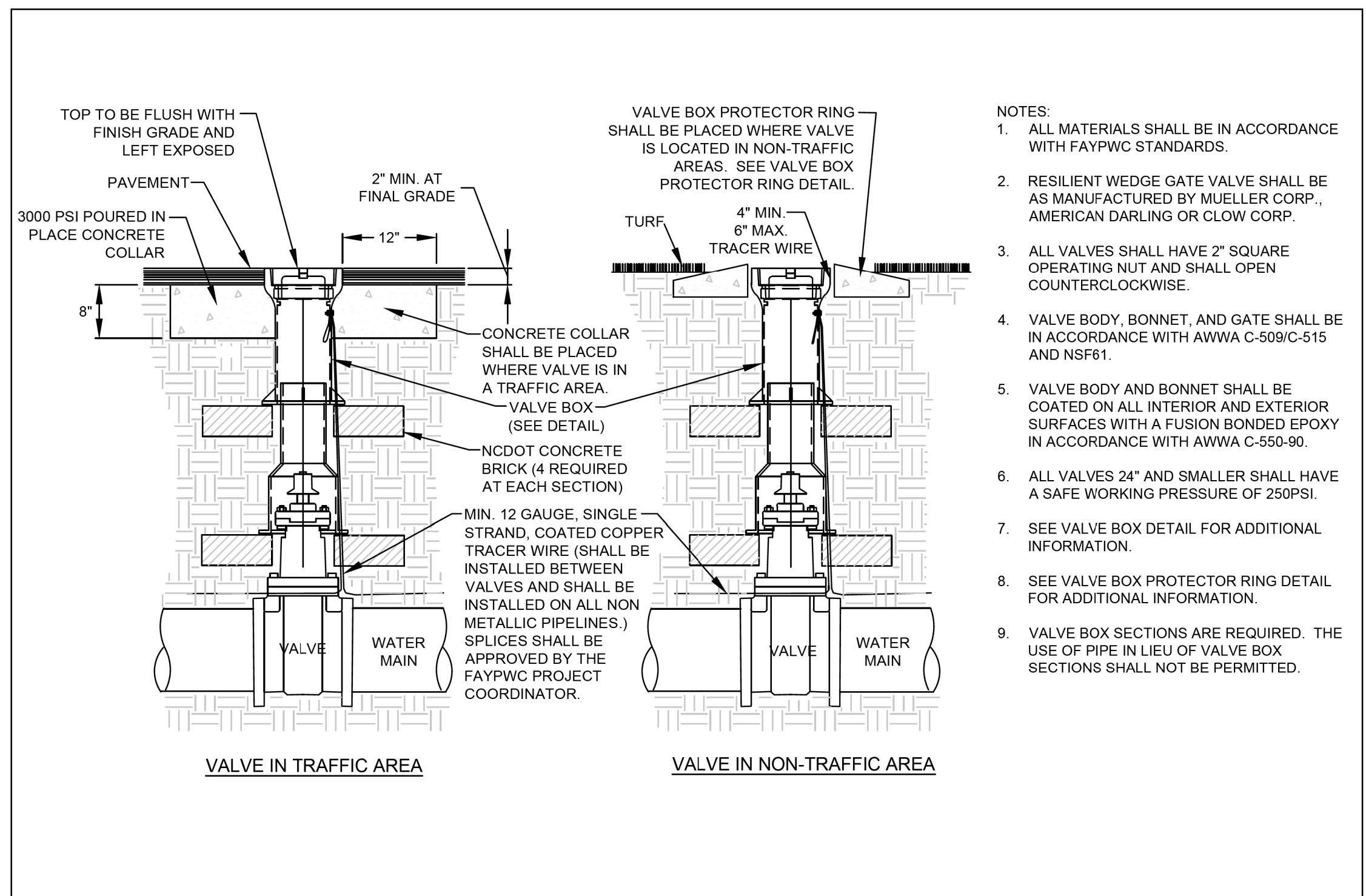

- NOTES:
1. ALL MATERIALS SHALL BE IN ACCORDANCE WITH FAYPWC STANDARDS.
  2. RESILIENT WEDGE GATE VALVE SHALL BE AS MANUFACTURED BY MUELLER CORP., AMERICAN DARLING OR CLOW CORP.
  3. ALL VALVES SHALL HAVE 2" SQUARE OPERATING NUT AND SHALL OPEN COUNTERCLOCKWISE.
  4. VALVE BODY, BONNET, AND GATE SHALL BE IN ACCORDANCE WITH AWWA C-509/C-515 AND NSF61.
  5. VALVE BODY AND BONNET SHALL BE COATED ON ALL INTERIOR AND EXTERIOR SURFACES WITH A FUSION BONDED EPOXY IN ACCORDANCE WITH AWWA C-550-90.
  6. ALL VALVES 24" AND SMALLER SHALL HAVE A SAFE WORKING PRESSURE OF 250PSI.
  7. SEE VALVE BOX DETAIL FOR ADDITIONAL INFORMATION.
  8. SEE VALVE BOX PROTECTOR RING DETAIL FOR ADDITIONAL INFORMATION.
  9. VALVE BOX SECTIONS ARE REQUIRED. THE USE OF PIPE IN LIEU OF VALVE BOX SECTIONS SHALL NOT BE PERMITTED.

GATE VALVE N.T.S.		FAYETTEVILLE PUBLIC WORKS COMMISSION FAYETTEVILLE, N.C.			NO.	DATE	REVISION
SHEET NO. 1 OF 1	DWG. NO. W.6 DATE: JAN. 01, 2022	DWG. BY: FAYPWC APPROVED BY: M.M.M.	WATER RESOURCES ENGINEERING DEPARTMENT		1	6/06	ADDED NOTE NO. 9
W6-GATEVALVE.dwg							

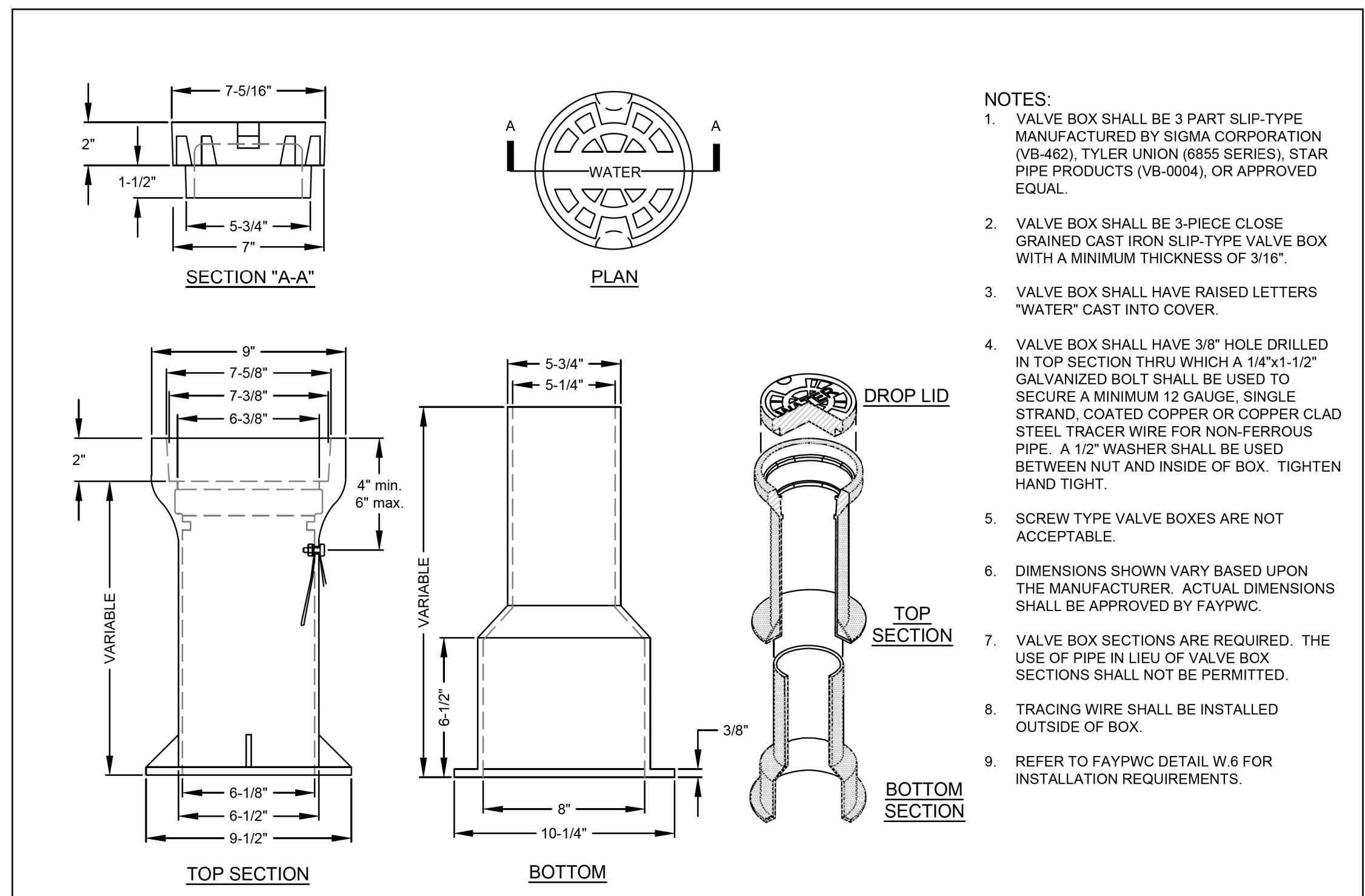

- NOTES:
1. VALVE BOX SHALL BE 3 PART SLIP-TYPE MANUFACTURED BY SIGMA CORPORATION (VB-462), TYLER UNION (6855 SERIES), STAR PIPE PRODUCTS (VB-0004), OR APPROVED EQUAL.
  2. VALVE BOX SHALL BE 3-PIECE CLOSE GRAINED CAST IRON SLIP-TYPE VALVE BOX WITH A MINIMUM THICKNESS OF 3/16".
  3. VALVE BOX SHALL HAVE RAISED LETTERS "WATER" CAST INTO COVER.
  4. VALVE BOX SHALL HAVE 3/8" HOLE DRILLED IN TOP SECTION THRU WHICH A 1/4"x1-1/2" GALVANIZED BOLT SHALL BE USED TO SECURE A MINIMUM 12 GAUGE, SINGLE STRAND, COATED COPPER OR COPPER CLAD STEEL TRACER WIRE FOR NON-FERROUS PIPE. A 1/2" WASHER SHALL BE USED BETWEEN NUT AND INSIDE OF BOX. TIGHTEN HAND TIGHT.
  5. SCREW TYPE VALVE BOXES ARE NOT ACCEPTABLE.
  6. DIMENSIONS SHOWN VARY BASED UPON THE MANUFACTURER. ACTUAL DIMENSIONS SHALL BE APPROVED BY FAYPWC.
  7. VALVE BOX SECTIONS ARE REQUIRED. THE USE OF PIPE IN LIEU OF VALVE BOX SECTIONS SHALL NOT BE PERMITTED.
  8. TRACING WIRE SHALL BE INSTALLED OUTSIDE OF BOX.
  9. REFER TO FAYPWC DETAIL W.6 FOR INSTALLATION REQUIREMENTS.

VALVE BOX N.T.S.		FAYETTEVILLE PUBLIC WORKS COMMISSION FAYETTEVILLE, N.C.			NO.	DATE	REVISION
SHEET NO. 1 OF 1	DWG. NO. W.7 DATE: JAN. 01, 2022	DWG. BY: FAYPWC APPROVED BY: M.M.M.	WATER RESOURCES ENGINEERING DEPARTMENT		1	07/09	ADDED NOTES 7, 8, AND CLARIFIED NOTES
W7-VALVEBOX.dwg							

# PROJECT TYPICAL DETAILS

PROJECT REFERENCE NO.	SHEET NO.
U-2519BA	UC-3C
DESIGNED BY: DJ	
DRAWN BY: DJ	
CHECKED BY: TR	
APPROVED BY: TR	
REVISED:	3/24/2022
UTILITY CONSTRUCTION PLANS ONLY	

## UTILITY CONSTRUCTION

**NOTE:**  
ANY REFERENCE TO FAYPWC PROJECT COORDINATOR, PWC COORDINATOR OR FAYPWC (FAYETTEVILLE PUBLIC WORKS COMMISSION) SHALL BE INTERPRETTED AS A REFERENCE TO THE ENGINEER.

**PLAN**  
N.T.S.

**SECTION A-A**  
N.T.S.

**CUT AWAY VIEW**  
N.T.S.

**NOTES:**

- CONCRETE PROTECTOR RING SHALL BE 2500PSI PRECAST REINFORCED CONCRETE.
- VALVE BOX SHALL BE AT GRADE WITH PROTECTOR RING EXTENDING 1/2" ABOVE GRADE.
- SEE GATE VALVE AND BOX DETAIL.
- VALVE BOX PROTECTOR RINGS SHALL BE INSTALLED AROUND VALVE BOX IN UNPAVED NON-TRAFFIC AREAS AND SHALL NOT CREATE A HINDRANCE TO MOWING OPERATIONS.

<b>VALVE BOX PROTECTOR RING</b> N.T.S.		<b>FAYETTEVILLE PUBLIC WORKS COMMISSION</b> FAYETTEVILLE, N.C.		NO.	DATE	REVISION
SHEET NO. 1 OF 1		WATER RESOURCES ENGINEERING DEPARTMENT				

W8-CONC-PROTECTOR-RING.dwg

**TAPPING VALVE**  
N.T.S.

**FAYETTEVILLE PUBLIC WORKS COMMISSION**  
FAYETTEVILLE, N.C.

**NOTES:**

- ALL MATERIALS SHALL BE IN ACCORDANCE WITH FAYPWC STANDARDS.
- RAISED MALE FACE SHALL BE REQUIRED TO PROVIDE FOR PROPER ALIGNMENT OF THE TAPPING SLEEVE.
- ALL VALVES SHALL HAVE 2" SQUARE OPERATING NUT AND SHALL OPEN COUNTERCLOCKWISE.
- RESILIENT WEDGE GATE VALVE SHALL BE AS MANUFACTURED BY MUELLER CORP., AMERICAN DARLING, CLOW CORP., OR APPROVED EQUAL.
- VALVE BODY, BONNET, AND GATE SHALL BE IN ACCORDANCE WITH AWWA C-509/C-515 AND NSF61. VALVE BODY AND BONNET SHALL BE COATED ON ALL INTERIOR AND EXTERIOR SURFACES WITH A FUSION BONDED EPOXY IN ACCORDANCE WITH AWWA C-550-90.
- ALL VALVES 24" AND SMALLER SHALL HAVE A SAFE WORKING PRESSURE OF 250PSI.
- SEE TAPPING SLEEVE (DETAIL W.10 OR W.11) FOR ADDITIONAL INFORMATION.
- DIMENSIONS SHOWN ARE FOR REFERENCE AND MAY VARY BASED UPON MANUFACTURER. VALVES SHALL BE SIMILAR IN NATURE TO THAT SHOWN AND SHALL NOT DEVIATE IN ESSENTIAL DETAILS.
- ALL TAPPING SLEEVES SHALL BE HYDROSTATICALLY PRESSURE TESTED IN ACCORDANCE WITH FAYPWC SPECIFICATIONS. TEST SHALL BE WITNESSED AND APPROVED BY FAYPWC PROJECT COORDINATOR PRIOR TO BEGINNING TAPPING PROCESS.

VALVE SIZE	A	B	C	D	E	F	G	H	J	K	L	M	N	R	S	T	URNS TO OPEN	WEIGHT W/ACC
4	4-3/8	5-7/8	15/16	1-1/2	9	7-1/2	4-7/8	4-63/64	4-29/32	2-1/2	7-1/2	9	14-1/8	9	8-3/4	1/4	14	118
6	6-7/8	6-1/4	1	1-5/8	11	9-1/2	6-7/8	6-63/64	7	2-1/2	9-1/2	11	17-5/8	11-3/4	8-7/8	1/4	21	175
8	6-1/2	7-1/4	1-1/8	1-3/4	13-1/4	11-3/4	6-7/8	8-63/64	9-5/32	2-1/2	11-3/4	13-1/2	21	14-1/4	8-7/8	1/4	28	274
12	7	8-1/4	1-1/4	1-3/4	17-7/8	16-1/4	6-7/8	12-63/64	13-5/16	2-1/2	17	19	28-1/4	19-7/8	12-1/4	1/4	39	570
16	8-1/2	9-1/8	1-7/16	2-1/8	23	21	12-7/8	16-15/16	17-35/64	3-1/2	21-1/4	23-1/2	38-5/8	28-1/8	16-1/8	1/4	55	1140
24	10-1/2	14-1/4	1-7/8	2-1/2	31-3/4	30	16-7/8	24-15/16	25-15/16	3-1/2	29-1/2	32	54-5/8	37-5/8	20-1/8	5/16	79	3225

<b>TAPPING VALVE</b> N.T.S.		<b>FAYETTEVILLE PUBLIC WORKS COMMISSION</b> FAYETTEVILLE, N.C.		NO.	DATE	REVISION
SHEET NO. 1 OF 1		WATER RESOURCES ENGINEERING DEPARTMENT				

W9-M.J.-TAPPING-VALVE.dwg

**DUCTILE IRON TAPPING SLEEVE**  
N.T.S.

**FAYETTEVILLE PUBLIC WORKS COMMISSION**  
FAYETTEVILLE, N.C.

**NOTES:**

- ALL MATERIALS SHALL BE IN ACCORDANCE WITH FAYPWC STANDARDS. SLEEVE BODY SHALL BE DUCTILE IRON ASTM A536.
- MECHANICAL JOINT TAPPING SLEEVES SHALL BE AS MANUFACTURED BY CLOW, M & H, MUELLER, OR AMERICAN AND SHALL BE FURNISHED WITH SPLIT GLANDS, SPLIT END GASKET, BOLTS, ETC. THE OUTLET FLANGE SHALL BE CL 125 PER ANSI B16.1 COMPATIBLE WITH APPROVED TAPPING VALVES.
- DIMENSIONS SHOWN ARE FOR REFERENCE AND MAY VARY BASED UPON MANUFACTURER. SLEEVES SHALL BE SIMILAR IN NATURE TO THAT SHOWN AND SHALL NOT DEVIATE IN ESSENTIAL DETAILS.
- PIPE SURFACES SHALL BE CLEANED THOROUGHLY TO PERMIT FOR A GOOD SEAL PRIOR TO INSTALLATION.
- EXTERIOR OF TAPPING SLEEVE SHALL BE COATED WITH 2 COATS ASPHALTIC VARNISH MIL-C450.
- ALL TAPPING SLEEVES SHALL BE HYDROSTATICALLY PRESSURE TESTED IN ACCORDANCE WITH FAYPWC SPECIFICATIONS. TEST SHALL BE WITNESSED AND APPROVED BY FAYPWC PROJECT COORDINATOR PRIOR TO BEGINNING TAPPING PROCESS.
- SEE DETAILS W.9 AND W.17 FOR ADDITIONAL REQUIREMENTS.

SLEEVE SIZE PIPE X BRANCH	6X6	8X6	8X8	12X6	12X8	12X12	16X6	16X8	16X12	24X6	24X8	24X12	24X16	24X24	30X6	30X8	30X12	30X16	30X24
A DIA +0.01-0.00	7.016	7.016	9.016	7.016	9.016	13.016	7.016	9.016	13.016	11.00	13.5	19.0	23.5	32.0	11.00	13.5	19.0	23.5	32.0
B	31	31	31	31	31	31	31	31	31	31	31	31	31	31	31	31	31	31	31
C	7-7/8	9-1/16	9	11-5/8	11-7/8	12-7/8	14-1/8	14-1/2	14-7/8	19.5	19.5	19.5	20.5	20.5	23.25	23.25	23.25	23.75	23.75
E	11-3/4	13-7/8	13-7/8	18-1/2	18-1/2	18-1/2	23-1/2	23-1/2	23-1/2	35.5	35.5	35.5	35.5	35.5	43.37	43.37	43.37	43.37	43.37
F	13-1/2	15	15	19-1/2	19-1/2	19-1/2	22-1/2	22-1/2	22-1/2	18.0	18.0	24.0	30.0	36.0	24.0	24.0	24.0	36.0	36.0

<b>DUCTILE IRON TAPPING SLEEVE</b> N.T.S.		<b>FAYETTEVILLE PUBLIC WORKS COMMISSION</b> FAYETTEVILLE, N.C.		NO.	DATE	REVISION
SHEET NO. 1 OF 1		WATER RESOURCES ENGINEERING DEPARTMENT				

W10-M.J.-TAPPING-SLEEVE.dwg

**FIRE HYDRANT AND VALVE INSTALLATION**  
N.T.S.

**FAYETTEVILLE PUBLIC WORKS COMMISSION**  
FAYETTEVILLE, N.C.

**NOTES:**

- ALL MATERIALS SHALL BE IN ACCORDANCE WITH FAYPWC STANDARDS. SLEEVE BODY SHALL BE DUCTILE IRON ASTM A536.
- MECHANICAL JOINT TAPPING SLEEVES SHALL BE AS MANUFACTURED BY CLOW, M & H, MUELLER, OR AMERICAN AND SHALL BE FURNISHED WITH SPLIT GLANDS, SPLIT END GASKET, BOLTS, ETC. THE OUTLET FLANGE SHALL BE CL 125 PER ANSI B16.1 COMPATIBLE WITH APPROVED TAPPING VALVES.
- DIMENSIONS SHOWN ARE FOR REFERENCE AND MAY VARY BASED UPON MANUFACTURER. SLEEVES SHALL BE SIMILAR IN NATURE TO THAT SHOWN AND SHALL NOT DEVIATE IN ESSENTIAL DETAILS.
- PIPE SURFACES SHALL BE CLEANED THOROUGHLY TO PERMIT FOR A GOOD SEAL PRIOR TO INSTALLATION.
- EXTERIOR OF TAPPING SLEEVE SHALL BE COATED WITH 2 COATS ASPHALTIC VARNISH MIL-C450.
- ALL TAPPING SLEEVES SHALL BE HYDROSTATICALLY PRESSURE TESTED IN ACCORDANCE WITH FAYPWC SPECIFICATIONS. TEST SHALL BE WITNESSED AND APPROVED BY FAYPWC PROJECT COORDINATOR PRIOR TO BEGINNING TAPPING PROCESS.
- SEE DETAILS W.9 AND W.17 FOR ADDITIONAL REQUIREMENTS.

<b>FIRE HYDRANT AND VALVE INSTALLATION</b> N.T.S.		<b>FAYETTEVILLE PUBLIC WORKS COMMISSION</b> FAYETTEVILLE, N.C.		NO.	DATE	REVISION
SHEET NO. 1 OF 2		WATER RESOURCES ENGINEERING DEPARTMENT				

W13-FHCC.dwg

P:\CAD\UC\Utilities\Engineering\UC\Proj\280\_011\_U2519BA\_UT\_DTL\_UC3C\_PSH.dgn  
 24-MAR-2022 11:30  
 P:\CAD\UC\Utilities\Engineering\UC\Proj\280\_011\_U2519BA\_UT\_DTL\_UC3C\_PSH.dwg

# PROJECT TYPICAL DETAILS



2550 WOODBURN ROAD  
 SUITE 110  
 FAYETTEVILLE, NC 28404  
 PHONE: 910.499.9999  
 NC COLA No. F-0002

PROJECT REFERENCE NO.	SHEET NO.
U-2519BA	UC-3D
DESIGNED BY: DJ	
DRAWN BY: DJ	
CHECKED BY: TR	
APPROVED BY: TR	
REVISED:	UTILITY CONSTRUCTION PLANS ONLY

## UTILITY CONSTRUCTION

NOTE:  
 ANY REFERENCE TO FAYPWC PROJECT COORDINATOR, PWC COORDINATOR OR FAYPWC (FAYETTEVILLE PUBLIC WORKS COMMISSION) SHALL BE INTERPRETTED AS A REFERENCE TO THE ENGINEER.

**NOTES:**

- FIRE HYDRANT SHALL BE MODELS MANUFACTURED BY MUELLER CO. (CENTURIAN), AMERICAN VALVE AND HYDRANT CO. (MODEL MARK 73), CLOW MEDALLION OR APPROVED EQUAL.
- ALL VALVES AND HYDRANTS SHALL HAVE M.J. CONNECTIONS WITH IRON RETAINING GLAND M.J. RESTRAINT.
- HYDRANT VALVE SHALL BE PLACED AS CLOSE AS POSSIBLE TO THE MAIN, BUT DO NOT PLACE VALVE IN PROPOSED OR EXISTING CURB AND GUTTER. IF THE STREET IS SOIL AND NO PAVING IS TO BE DONE AT THIS TIME, THE LOCATION OF THE VALVE IS TO BE DETERMINED BY THE PWC PROJECT COORDINATOR.
- HYDRANT BRANCH SHALL NOT BE BACK FILLED UNTIL INSPECTED AND APPROVED BY FAYPWC PROJECT COORDINATOR.
- GATE VALVE AND BOX SHALL BE IN ACCORDANCE WITH FAYPWC STANDARD DETAIL.
- HYDRANT EXTENSIONS AND/OR OFFSETS SHALL BE APPROVED BY FAYPWC PROJECT COORDINATOR.
- FIRE HYDRANT CONNECTIONS TO EXISTING WATER MAINS SHALL BE MADE USING A TAPPING SLEEVE AND VALVE BY WET TAP CONNECTION. THE TAPPING SLEEVE AND VALVE SHALL BE HYDROSTATICALLY TESTED PRIOR TO STARTING THE TAP IN THE PRESENCE OF THE FAYPWC PROJECT COORDINATOR.
- THE PROPOSED LOCATION MAY BE RELOCATED BY THE FAYPWC PROJECT COORDINATOR IF CONFLICTS EXIST (IE: GAS SERVICES, UGE, TELEPHONE, ETC.).
- THE CONTRACTOR SHALL FIELD VERIFY THE EXISTING WATER MAIN MATERIAL, SIZE, AND DEPTH FOR EACH FIRE HYDRANT LOCATION PRIOR TO ORDERING MATERIALS. THE CONTRACTOR WILL BE REQUIRED TO SUPPLY VARIOUS LENGTHS OF BARRELS AND HYDRANT EXTENSIONS (NO MORE THAN ONE HYDRANT EXTENSION MAY BE USED PER HYDRANT). ADDITIONAL FITTINGS AND/OR HYDRANT EXTENSIONS OR OFFSET CONNECTORS MAY BE REQUIRED TO MAINTAIN PROPER COVER AS APPROVED BY THE FAYPWC PROJECT COORDINATOR.
- CONTRACTOR SHALL NOTIFY THE APPROPRIATE FIRE DEPARTMENT OF OUT OF SERVICE FIRE HYDRANTS PRIOR TO CONSTRUCTION.
- FIRE HYDRANT SHALL BE FIELD PAINTED IN ACCORDANCE WITH FAYPWC STANDARDS, BEFORE PROJECT IS ACCEPTED. HYDRANTS SHALL BE PAINTED WITH A GREEN BONNET AND YELLOW BODY. PAINT SHALL BE IN ACCORDANCE WITH FAYPWC REQUIREMENTS. THE CONTRACTOR SHALL PAINT ALL EXPOSED EXTERIOR FIRE HYDRANT SURFACES PRIOR TO FINAL ACCEPTANCE BY FAYPWC. ALL PAINTING SHALL BE DONE IN STRICT ACCORDANCE WITH THE PAINT MANUFACTURER'S RECOMMENDATIONS AND SHALL BE SATISFACTORY TO THE FAYPWC.
- PROTECTIVE COVERING SHALL BE UTILIZED, AS NECESSARY FOR PROTECTION OF ADJACENT AREAS, EQUIPMENT, SHRUBBERY, OR OTHER ITEMS. AFTER PAINTING IS COMPLETE, THE ENTIRE AREA SHALL BE THOROUGHLY CLEANED UP.
- ALL PAINT MATERIALS SHALL BE IN THE ORIGINAL SEALED CONTAINERS BEARING THE MANUFACTURER'S NAME.
- WHERE NECESSARY, THINNING SHALL BE DONE IN ACCORDANCE WITH THE MANUFACTURER'S INSTRUCTIONS, AND AS APPROVED BY FAYPWC.
- ALL SURFACES TO BE PAINTED SHALL BE CLEAN AND DRY.
- THE BONNET OF THE FIRE HYDRANT SHALL BE PAINTED A DARK GREEN, UTILIZING AN ALKYD OR POLYURETHANE ENAMEL, WITH A FINAL DRY MIL THICKNESS OF 4 TO 6 MILS. MULTIPLE COATS MAY BE NECESSARY TO ACHIEVE THE FINAL REQUIRED DRY MIL THICKNESS. THE PAINT SHALL BE FOREST GREEN, SAMPLES SHALL BE SUBMITTED TO FAYPWC.
- THE REMAINDER OF THE FIRE HYDRANT SHALL BE PAINTED SAFETY YELLOW, UTILIZING AN ALKYD OR POLYURETHANE ENAMEL, WITH A FINAL DRY MIL THICKNESS OF 4 TO 6 MILS. MULTIPLE COATS MAY BE NECESSARY TO ACHIEVE THE FINAL REQUIRED DRY MIL THICKNESS. THE PAINT SHALL BE YELLOW, SAMPLES SHALL BE SUBMITTED TO FAYPWC.

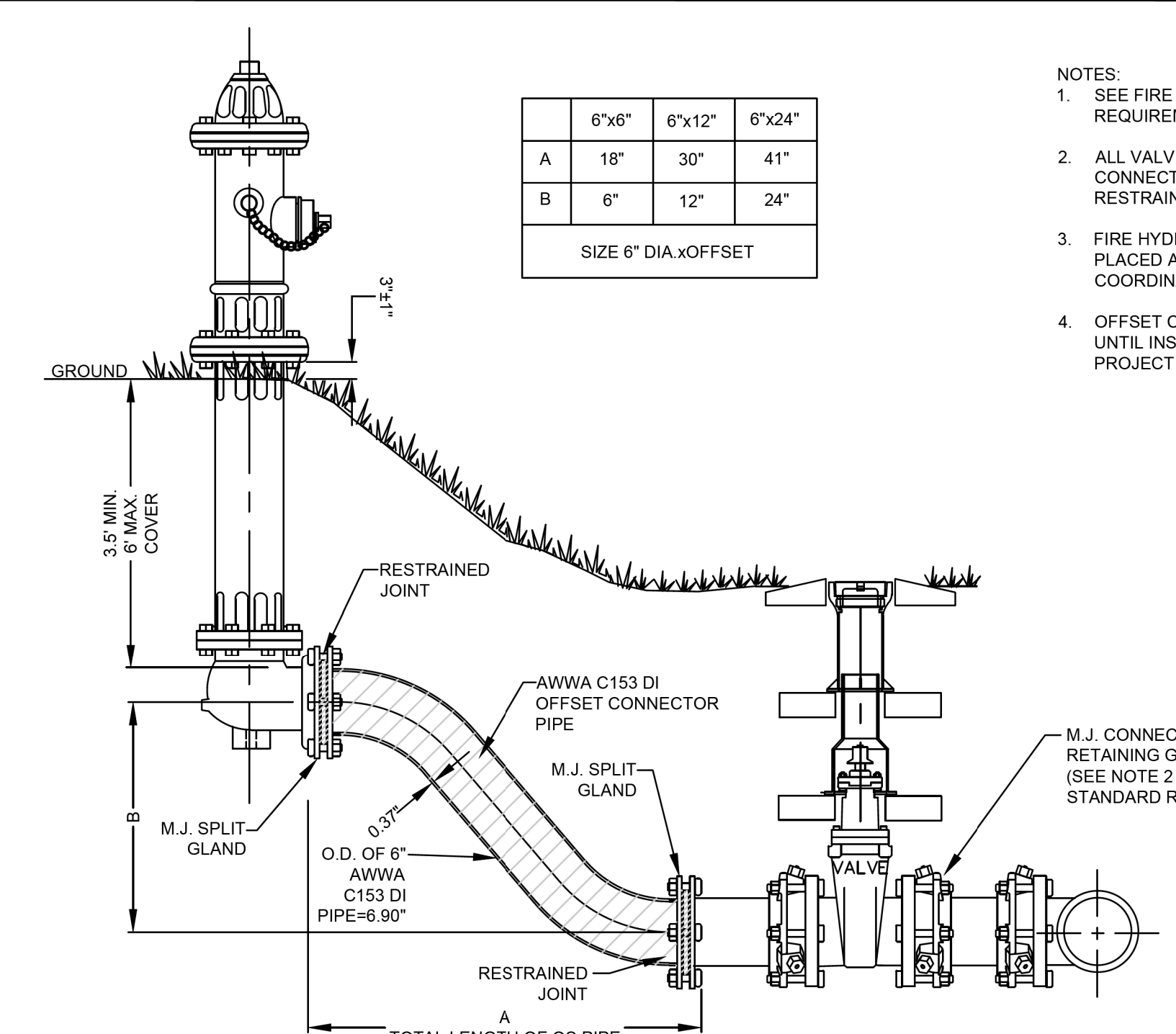

- NOTES:**
- SEE FIRE HYDRANT DETAIL W.13 FOR ADDITIONAL REQUIREMENTS.
  - ALL VALVES AND HYDRANTS SHALL HAVE M.J. CONNECTIONS WITH IRON RETAINING GLAND M.J. RESTRAINT.
  - FIRE HYDRANT OFFSET CONNECTOR SHALL BE PLACED AS APPROVED BY THE FAYPWC PROJECT COORDINATOR.
  - OFFSET CONNECTOR SHALL NOT BE BACK FILLED UNTIL INSPECTED AND APPROVED BY FAYPWC PROJECT COORDINATOR.

FIRE HYDRANT AND VALVE INSTALLATION N.T.S.		FAYETTEVILLE PUBLIC WORKS COMMISSION FAYETTEVILLE, N.C.		NO.	DATE	REVISION
SHEET NO. 2 OF 2	DWG. NO. W.13 DATE: JAN. 01, 2022	DWG. BY: FAYPWC APPROVED BY: M.M.M.	WATER RESOURCES ENGINEERING DEPARTMENT			
				1	10/23/03	REVISED NOTE NO. 4
				2	07/01/09	REVISED NOTE NO. 2, REMOVED NOTE NO. 3 AND ALTERED RESTRAINT DETAIL
				3	07/01/16	REVISED NOTES

W13-FHCC.dwg

RESTRAINED JOINT FIRE HYDRANT OFFSET CONNECTOR (STEEP BANK) N.T.S.		FAYETTEVILLE PUBLIC WORKS COMMISSION FAYETTEVILLE, N.C.		NO.	DATE	REVISION
SHEET NO. 1 OF 2	DWG. NO. W.14 DATE: JAN. 01, 2022	DWG. BY: FAYPWC APPROVED BY: M.M.M.	WATER RESOURCES ENGINEERING DEPARTMENT			
				1	07/09	REVISED NOTES 1, 2, AND 3

W14-FH-OFFSET.dwg

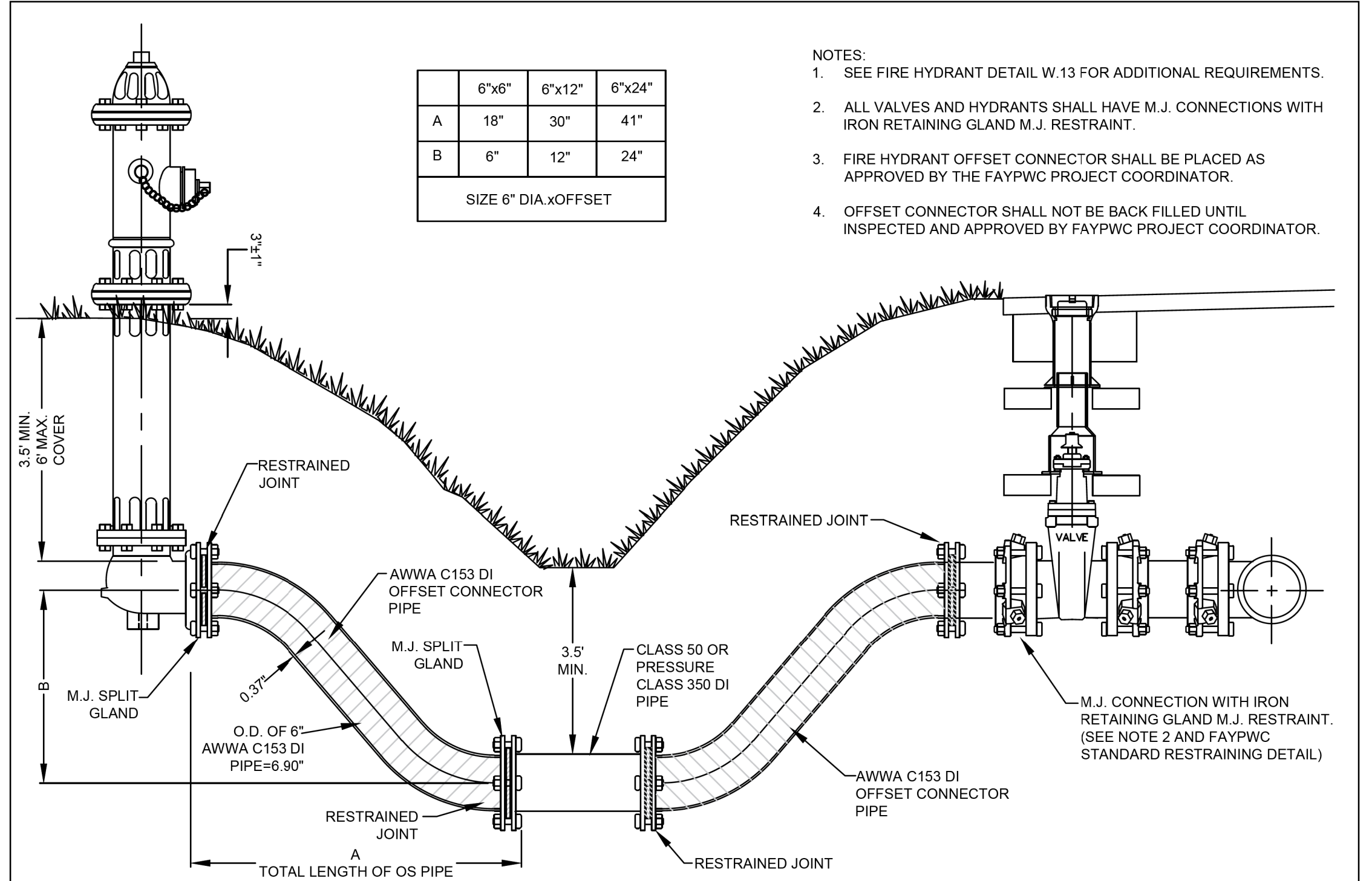

- NOTES:**
- SEE FIRE HYDRANT DETAIL W.13 FOR ADDITIONAL REQUIREMENTS.
  - ALL VALVES AND HYDRANTS SHALL HAVE M.J. CONNECTIONS WITH IRON RETAINING GLAND M.J. RESTRAINT.
  - FIRE HYDRANT OFFSET CONNECTOR SHALL BE PLACED AS APPROVED BY THE FAYPWC PROJECT COORDINATOR.
  - OFFSET CONNECTOR SHALL NOT BE BACK FILLED UNTIL INSPECTED AND APPROVED BY FAYPWC PROJECT COORDINATOR.

RESTRAINED JOINT FIRE HYDRANT OFFSET CONNECTOR AT DITCH N.T.S.		FAYETTEVILLE PUBLIC WORKS COMMISSION FAYETTEVILLE, N.C.		NO.	DATE	REVISION
SHEET NO. 2 OF 2	DWG. NO. W.14 DATE: JAN. 01, 2022	DWG. BY: FAYPWC APPROVED BY: M.M.M.	WATER RESOURCES ENGINEERING DEPARTMENT			
				1	01/05	ADDED NOTES
				2	07/09	REVISED NOTES 1, 2, AND 3

W14-FH-OFFSET.dwg

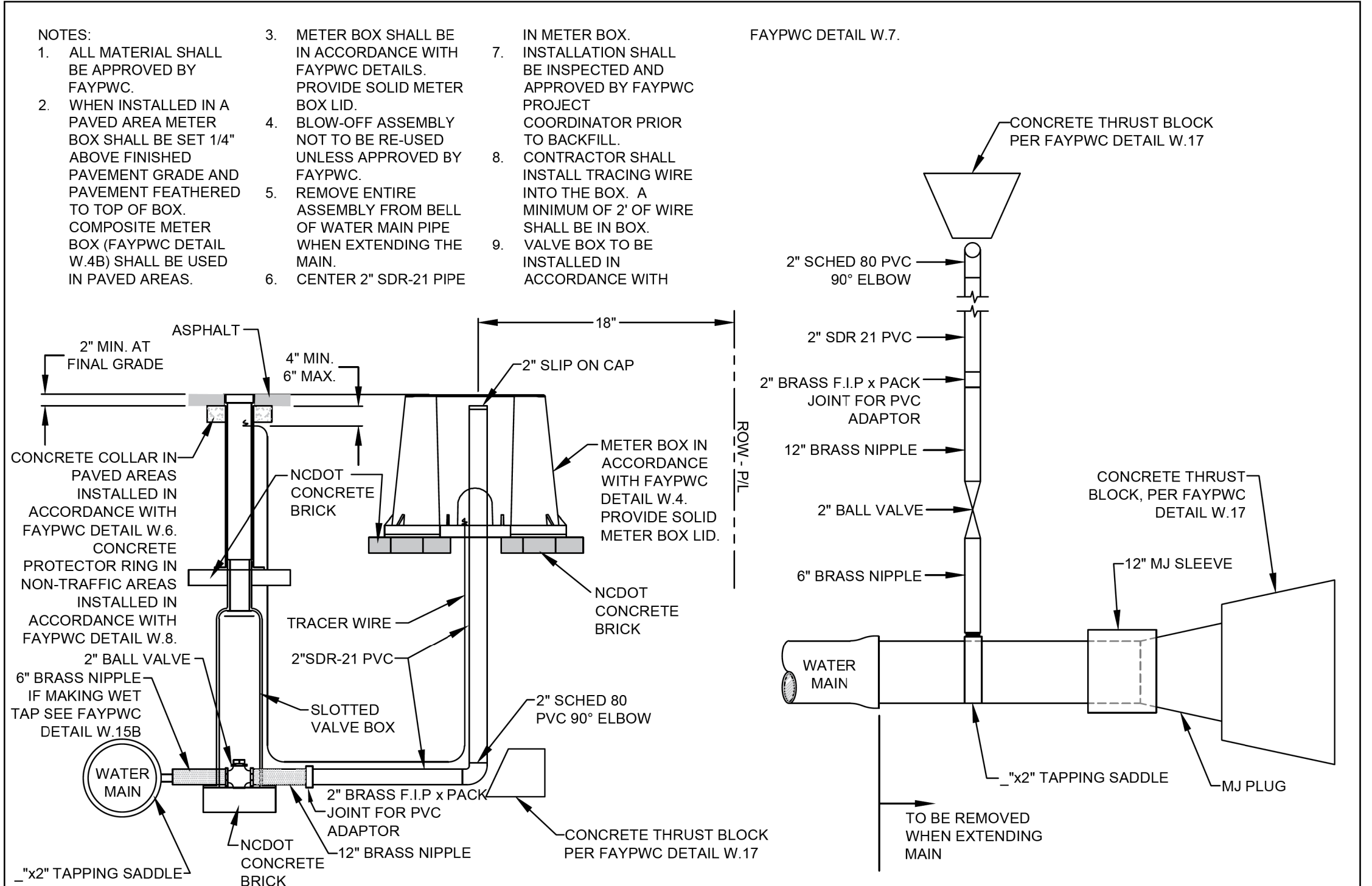

- NOTES:**
- ALL MATERIAL SHALL BE APPROVED BY FAYPWC.
  - WHEN INSTALLED IN A PAVED AREA METER BOX SHALL BE SET 1/4\"/>

- NOTES:**
- METER BOX SHALL BE IN ACCORDANCE WITH FAYPWC DETAILS. PROVIDE SOLID METER BOX LID.
  - BLOW-OFF ASSEMBLY NOT TO BE RE-USED UNLESS APPROVED BY FAYPWC.
  - REMOVE ENTIRE ASSEMBLY FROM BELL OF WATER MAIN PIPE WHEN EXTENDING THE MAIN.
  - CENTER 2\"/>

2\"/>						
SHEET NO. 1 OF 1	DWG. NO. W.15 DATE: JAN. 01, 2022	DWG. BY: FAYPWC APPROVED BY: M.M.M.	WATER RESOURCES ENGINEERING DEPARTMENT	NO.	DATE	REVISION
				2	11/06	REVISED CONFIGURATION
				3	07/17	REVISED NOTES

W15-2-BLOWOFF.dwg

241\\MAPS\2022\13\Utilities\Engineering\UC\Proj\280\_013\_U2519BA\_UT\_DTL\_UC30\_PSH.dgn  
 5/14/2022 10:58:33 AM



# PROJECT TYPICAL DETAILS



24-MAR-2022 11:37  
N:\CAD\CAD\Utilities\Engineering\UC\Proj\280\_015\_U2519BA\_UT\_DTL\_UC3E\_PSH.dgn

PROJECT REFERENCE NO.	SHEET NO.
U-2519BA	UC-3E
DESIGNED BY: DJ	
DRAWN BY: DJ	
CHECKED BY: TR	
APPROVED BY: TR	
REVISED:	3/24/2022
UTILITY CONSTRUCTION PLANS ONLY	

## UTILITY CONSTRUCTION

NOTE:  
ANY REFERENCE TO FAYPWC PROJECT COORDINATOR, PWC COORDINATOR OR FAYPWC (FAYETTEVILLE PUBLIC WORKS COMMISSION) SHALL BE INTERPRETTED AS A REFERENCE TO THE ENGINEER.

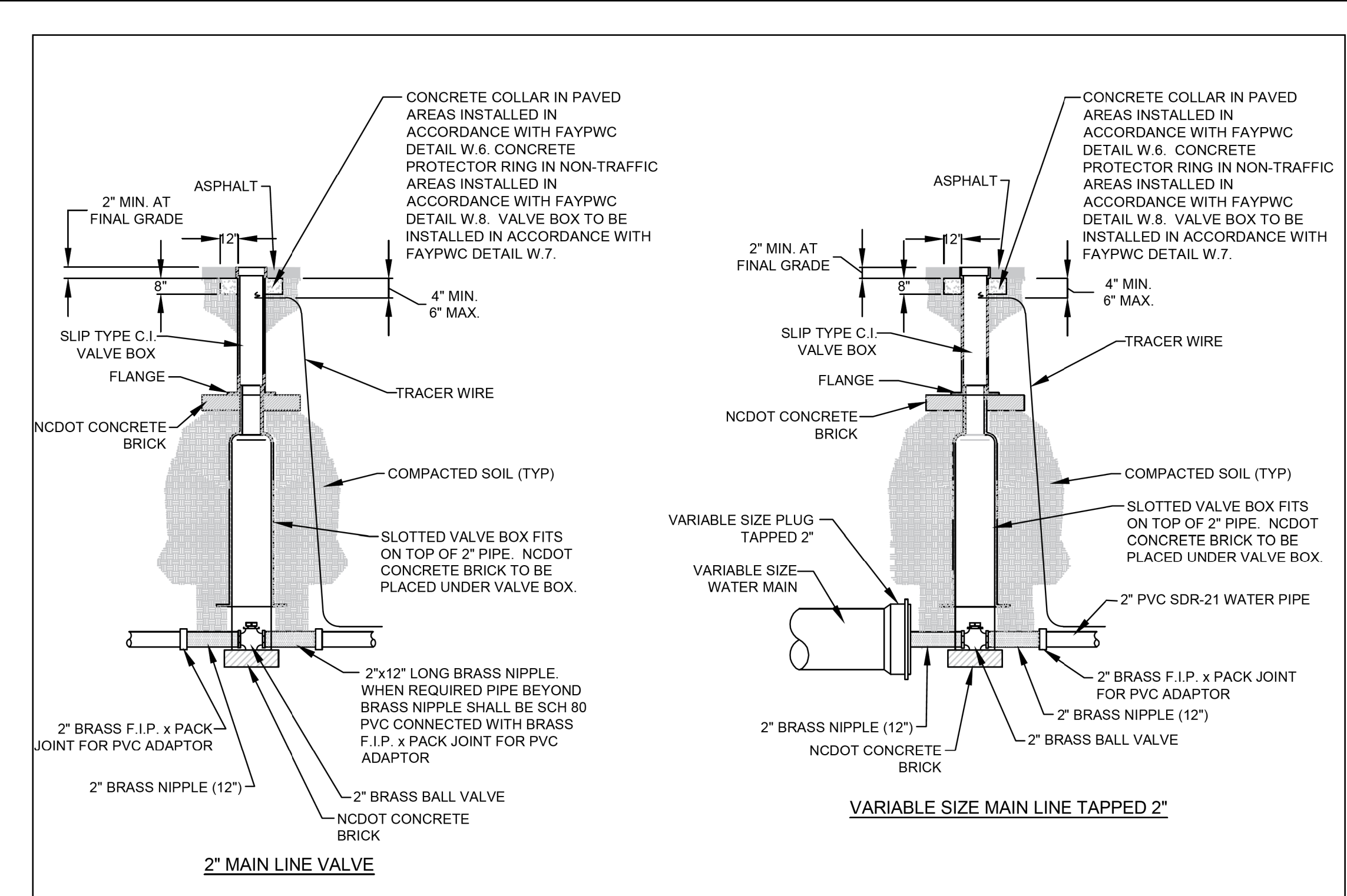

2" VALVE INSTALLATION N.T.S.		FAYETTEVILLE PUBLIC WORKS COMMISSION FAYETTEVILLE, N.C.		NO.	DATE	REVISION
SHEET NO. 1 OF 1	DWG. NO. W.15A	DATE: JAN. 01, 2022		1	06/06	ADDED NOTE ON CONCRETE COLLAR
DWG. BY: FAYPWC		APPROVED BY: M.M.M.	2	07/17	UPDATED NOTES	
WATER RESOURCES ENGINEERING DEPARTMENT			W15A-2-VALVE-INSTALLATION.dwg			

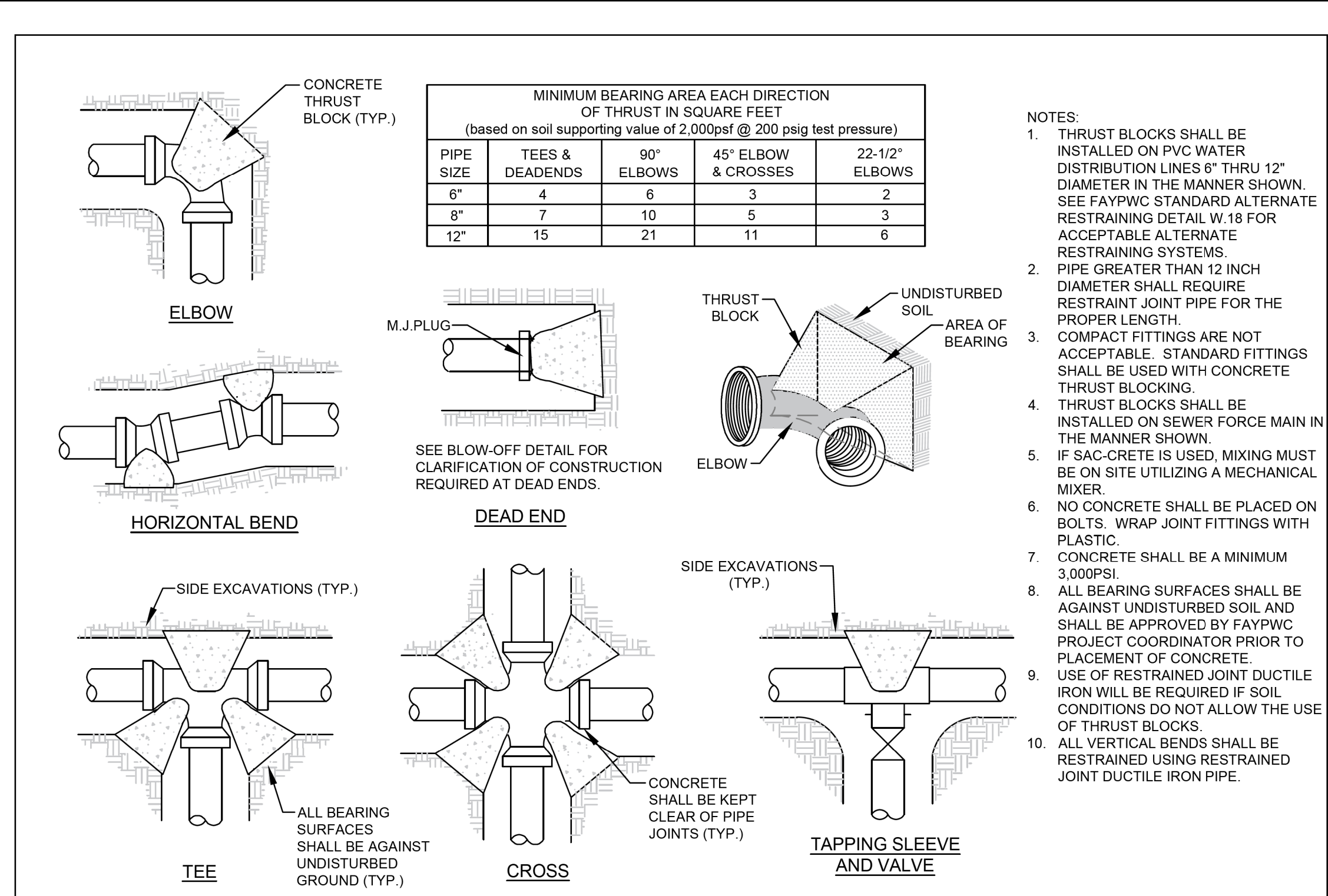

CONCRETE THRUST BLOCK DETAIL N.T.S.		FAYETTEVILLE PUBLIC WORKS COMMISSION FAYETTEVILLE, N.C.		NO.	DATE	REVISION
SHEET NO. 1 OF 1	DWG. NO. W.17	DATE: JAN. 01, 2022		1	09/05	REVISED TABLE
DWG. BY: FAYPWC		APPROVED BY: M.M.M.	2	02/07	ADDED NOTES 9 AND 10	
WATER RESOURCES ENGINEERING DEPARTMENT			3	07/13	ADDED TAPPING SLEEVE AND VALVE DETAIL	
W17-THRUSTBLOCK.dwg						

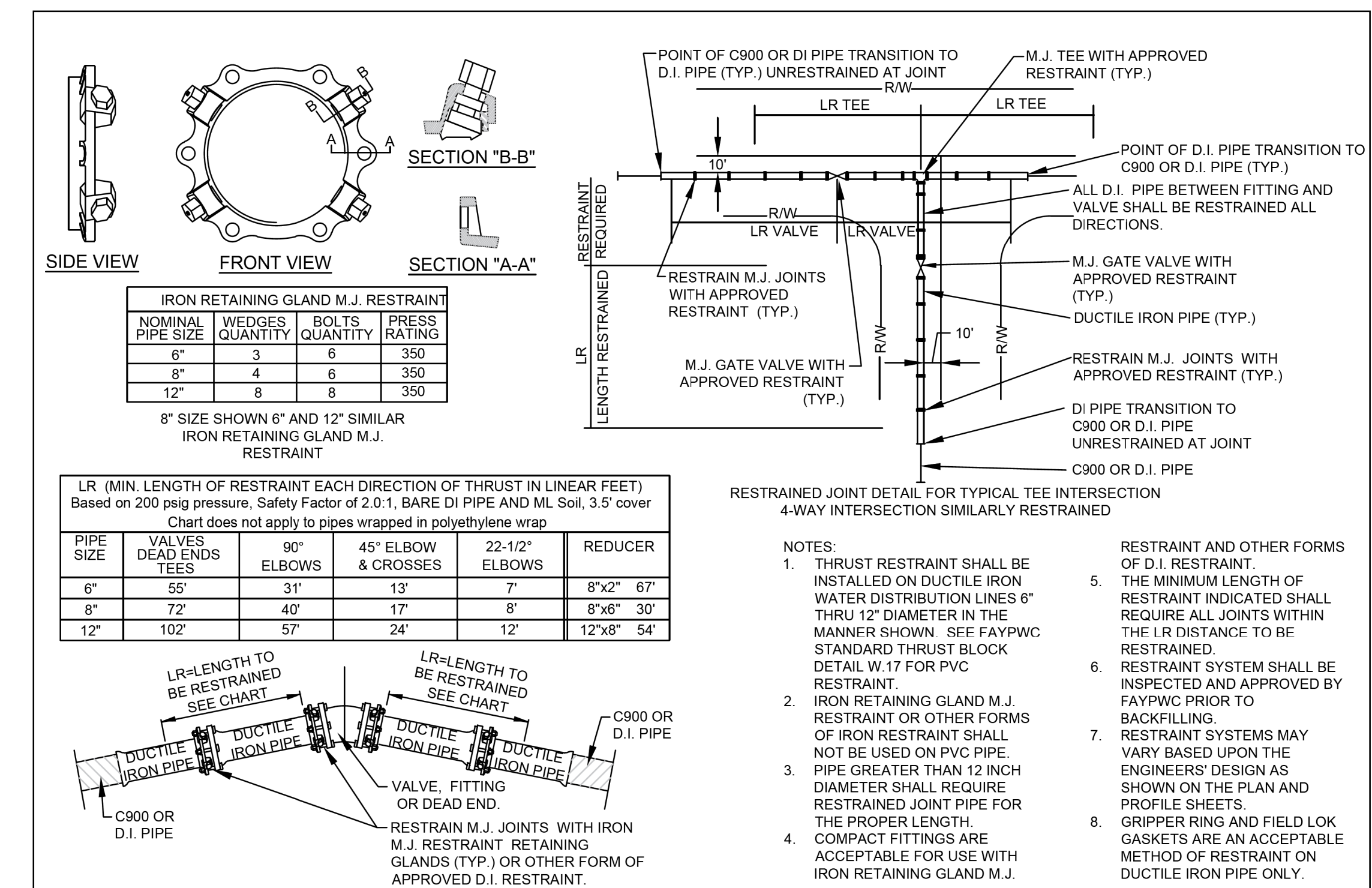

ALTERNATE RESTRAINT DETAIL (DUCTILE IRON PIPE ONLY) N.T.S.		FAYETTEVILLE PUBLIC WORKS COMMISSION FAYETTEVILLE, N.C.		NO.	DATE	REVISION
SHEET NO. 1 OF 1	DWG. NO. W.18	DATE: JAN. 01, 2022		1	11/16/07	REVISED TABLE, ADDED NOTE 8
DWG. BY: FAYPWC		APPROVED BY: M.M.M.	2	07/01/13	REVISED NOTE RE: TRACER WIRE	
WATER RESOURCES ENGINEERING DEPARTMENT			W18-RESTRAINT-DETAIL.dwg			

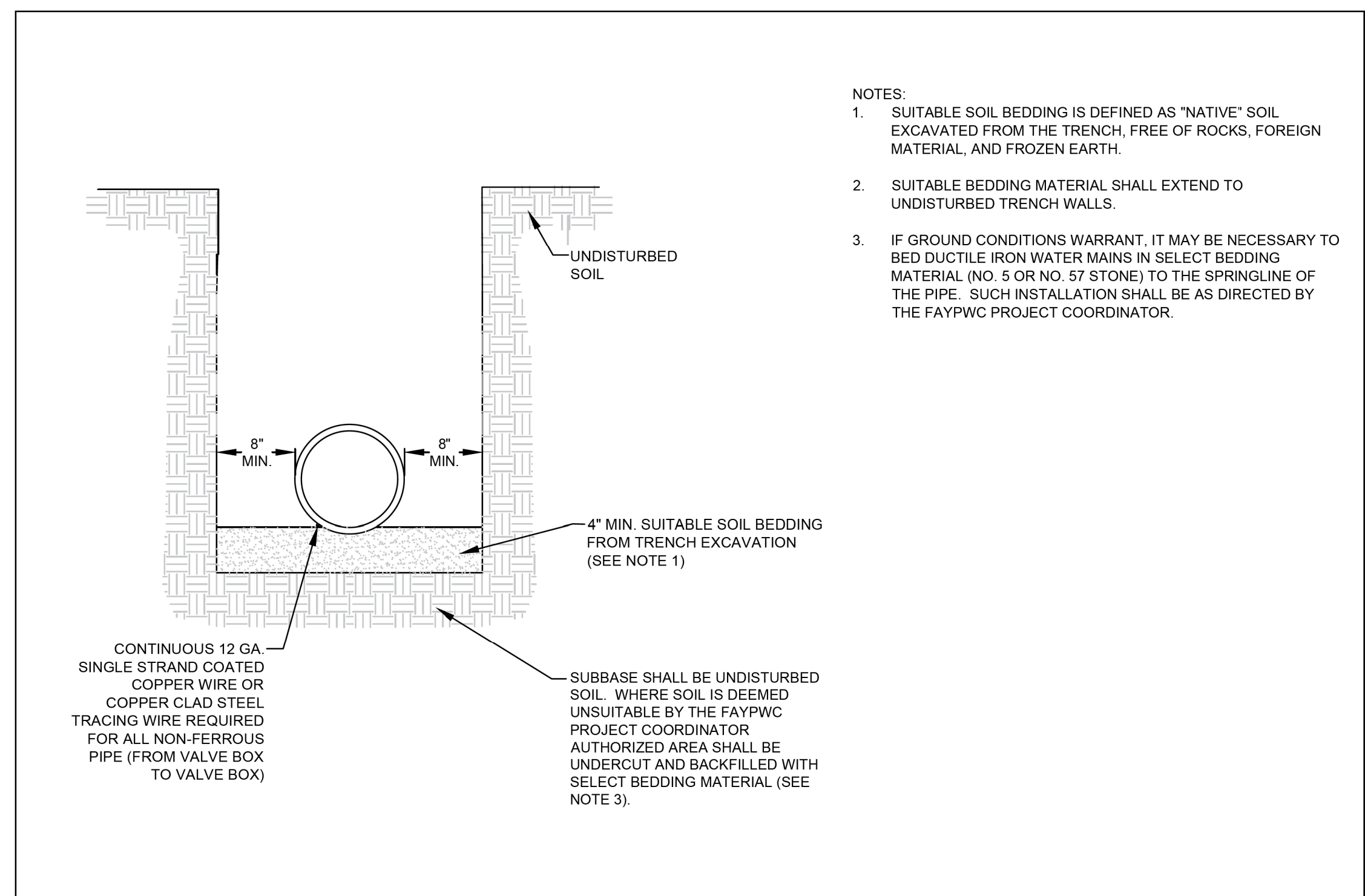

WATER MAIN BEDDING DETAIL N.T.S.		FAYETTEVILLE PUBLIC WORKS COMMISSION FAYETTEVILLE, N.C.		NO.	DATE	REVISION
SHEET NO. 1 OF 1	DWG. NO. W.19	DATE: JAN. 01, 2022		1	01/01/17	REVISED NOTES
DWG. BY: FAYPWC		APPROVED BY: M.M.M.	2	07/01/13	REVISED NOTE RE: TRACER WIRE	
WATER RESOURCES ENGINEERING DEPARTMENT			W19-WATER-BEDDING.dwg			

# PROJECT TYPICAL DETAILS



24-MAR-2020 11:37  
 \CAD\CAD\Civil\Utilities\Engineering\UC\Proj\280\_017\_U2519BA\_UT\_DTL\_UC3F\_PSH.dgn

PROJECT REFERENCE NO.	SHEET NO.
U-2519BA	UC-3F
DESIGNED BY: DJ	
DRAWN BY: DJ	
CHECKED BY: TR	
APPROVED BY: TR	
REVISED:	3/24/2022
UTILITY CONSTRUCTION PLANS ONLY	

## UTILITY CONSTRUCTION

NOTE:  
 ANY REFERENCE TO FAYPWC PROJECT COORDINATOR, PWC COORDINATOR OR FAYPWC (FAYETTEVILLE PUBLIC WORKS COMMISSION) SHALL BE INTERPRETTED AS A REFERENCE TO THE ENGINEER.

**NOTES:**

- KILL OUT SHALL BE DONE A MINIMUM OF 5 FEET FROM ANY FITTING ON THE EXISTING WATER MAIN THAT IS TO REMAIN IN SERVICE.
- IRON PIPE SHALL BE 4" DIAMETER FOR MAINS 12" OR LESS. UTILIZE 8" PIPE OR LARGER AS DIRECTED BY THE FAYPWC PROJECT COORDINATOR FOR ALL MAINS LARGER THAN 12".
- ALLOW CONCRETE TO SET-UP PRIOR TO PLACING BACKFILL.
- VOLUME OF CONCRETE FOR THRUST BLOCK SHALL BE IN ACCORDANCE WITH FAYPWC STANDARD DETAIL W.17.
- ALL OUTAGES SHALL BE COORDINATED WITH THE FAYPWC PROJECT COORDINATOR.
- PIPE SHALL BE GROUT FILLED OR REMOVED IN ACCORDANCE WITH NCDOT SPECIFICATIONS WHEN LOCATED IN THE STATE RIGHT-OF-WAY. ALL OTHER INSTANCES SHALL BE IN ACCORDANCE WITH FAYPWC SPECIFICATIONS.

STIFF KNEE SHALL BE ENCASED IN CONCRETE AS DIRECTED BY THE FAYPWC PROJECT COORDINATOR. CONCRETE SHALL COVER THE ABANDONED PIPE BUT SHALL NOT COME IN CONTACT WITH THE LIVE WATER MAIN OR FITTINGS IN ANY WAY.

DUCTILE IRON PIPE STIFF KNEE 5 FOOT MINIMUM OR AS APPROVED BY FAYPWC PROJECT COORDINATOR.

FULL BODY MECHANICAL JOINT SLEEVE WITH MEGALUG RESTRAINING GLAND (DUCTILE IRON PIPE ONLY) AND MECHANICAL JOINT CAP.

DUCTILE IRON OR PVC WATER MAIN TO REMAIN IN SERVICE.

CAP BLOCKS PLACED TO SUPPORT STIFF KNEE WHILE CONCRETE IS BEING POURED.

FAYPWC APPROVED TRANSITION FITTING.

AC WATER MAIN TO REMAIN IN SERVICE.

DUCTILE IRON PIPE 5 FOOT MINIMUM WITH MECHANICAL JOINT CAP WITH MEGALUG RESTRAINING GLAND OR FULL BODY MECHANICAL JOINT SLEEVE WITH MEGALUG RESTRAINING GLAND.

CAP BLOCKS PLACED TO SUPPORT STIFF KNEE WHILE CONCRETE IS BEING POURED.

MINIMUM 1/4" STEEL PLATE OR DUCTILE IRON CAP OR PLUG AS APPROVED BY FAYPWC PROJECT COORDINATOR.

PLUG END OF ABANDONED PIPE WITH BRICK AND MORTAR.

ABANDONED WATER MAIN

METAL PLATE OR DUCTILE IRON CAP OR PLUG AS APPROVED BY FAYPWC PROJECT COORDINATOR.

DUCTILE IRON PIPE STIFF KNEE 5 FOOT MINIMUM OR AS APPROVED BY FAYPWC PROJECT COORDINATOR.

<b>WATER MAIN KILL-OUT</b> N.T.S.		<b>FAYETTEVILLE PUBLIC WORKS COMMISSION</b> FAYETTEVILLE, N.C.		NO.	DATE	REVISION
SHEET NO. 1 OF 1		<b>WATER RESOURCES ENGINEERING DEPARTMENT</b>				
DWG. NO. W.22	DWG. BY: FAYPWC					
DATE: JAN. 01, 2022	APPROVED BY: M.M.M.					

W22-WATERMAIN-KILLOUT.dwg

FINISHED GRADE

PAVEMENT

CONCRETE CURB AND GUTTER

VARIES

18"

PROPERTY LINE

8" MIN TO 10" MAX

EQ

EQ

1" FULL PORT ANGLE BALL VALVE WITH ONE OR TWO STEP STYLE COMPRESSION FOR 1" TYPE K SOFT COPPER INLET AND FEMALE METER THREAD SWIVEL NUT WITH LOCK.

1" CC SINGLE STAINLESS STEEL STRAP SADDLE

3'-6" MIN

WATER MAIN

1" TYPE K SOFT COPPER

12" METER COUPLING WITH 3/4" FEMALE THREAD METER SWIVEL NUT x 3/4" MIPT. (NOTE: USE 1" FOR IRRIGATION SERVICE)

1"x7-1/2" SPACER FOR DOMESTIC SERVICE, 1"x10-3/4" SPACER FOR IRRIGATION SERVICE, SPACER SHALL BE FURNISHED BY FAYPWC.

NCDOT CONCRETE BRICK METER BOX BASE SEE INSET "A"

SECTION "A-A" BRICK METER BOX BASE INSET "A"

PLAN

SPACER SHALL BE CENTERED IN METER BOX

**NOTES:**

- ALL MATERIALS TO BE APPROVED BY FAYPWC.
- SERVICE LATERAL SIZE 1" TYPE K SOFT COPPER UNLESS OTHERWISE SPECIFIED.
- WATER SERVICE LOCK VALVE TO BE LOCATED 18" FROM SANITARY SEWER CLEAN-OUT STACK WHEN INSTALLED IN SAME DITCH.
- WHEN INSTALLED IN A PAVED AREA, METER BOX TO BE SET 1/4" ABOVE FINISHED PAVEMENT GRADES AND PAVEMENT FEATHERED TO TOP OF BOX TO PROVIDE DRAIN AWAY FROM BOX.
- COMPOSITE METER BOXES SHALL BE USED IN TRAFFIC AREAS SEE FAYPWC DETAIL W.4B.
- INSTALL NCDOT CONCRETE BRICK BASE WITH NO GAPS. DO NOT LAY BRICK ON PIPE. SEE INSET "A".
- WHERE ASPHALT CURB OR STRIP PAVEMENT EXISTS, THE LOCATION OF BOX SHALL BE AS DIRECTED BY FAYPWC REPRESENTATIVE.
- DISTANCE FROM TOP OF LOCK VALVE OPERATING STEM TO TOP OF BOX SHALL BE 8" MINIMUM TO 10" MAXIMUM.
- RESIDENTIAL METER BOX SHALL BE SET 18" FROM RW TO CENTERLINE OF METER BOX PERPENDICULAR TO THE RIGHT-OF-WAY.
- COMMERCIAL METER BOX LOCATION SHALL BE AS APPROVED (PREFER NO METER BE INSTALLED LESS THAN 5' FROM BUILDING TO EDGE OF BOX).
- LATERAL SHALL BE CENTERED ON LOT UNLESS OTHERWISE NOTED.
- LATERAL SHALL NOT BE BACKFILLED UNTIL INSPECTED AND APPROVED BY FAYPWC PROJECT COORDINATOR.
- WATER MAIN AND LATERAL SHALL PASS HYDROSTATIC AND STERILIZATION TESTS.
- SHOULD IT BE NECESSARY TO CRIMP THE WATER SERVICE LATERAL, A FULL CIRCLE REPAIR CLAMP SHALL BE PLACED ON THE CRIMPED AREA.

<b>1" COPPER WATER SERVICE LATERAL</b> N.T.S.		<b>FAYETTEVILLE PUBLIC WORKS COMMISSION</b> FAYETTEVILLE, N.C.		NO.	DATE	REVISION
SHEET NO. 1 OF 1		<b>WATER RESOURCES ENGINEERING DEPARTMENT</b>				
DWG. NO. W.24	DWG. BY: FAYPWC			2	09/05	VALVE CHANGE, ADD NOTE 16
DATE: JAN. 01, 2022	APPROVED BY: M.M.M.			3	07/06	RESIZED METER COUPLING
				4	07/17	RESIZED NOTES

W24-COPPER-SERVICE-LATERAL.dwg

FINISHED GRADE

PAVEMENT

CONCRETE CURB AND GUTTER

VARIES

18"

PROPERTY LINE

8" MIN TO 10" MAX

EQ

EQ

1" FULL PORT ANGLE BALL VALVE WITH ONE OR TWO STEP STYLE COMPRESSION FOR 1" TYPE K SOFT COPPER INLET AND FEMALE METER THREAD SWIVEL NUT WITH LOCK.

1" CC SINGLE STAINLESS STEEL STRAP SADDLE

3'-6" MIN

WATER MAIN

1" TYPE K SOFT COPPER

12" METER COUPLING WITH 3/4" FEMALE THREAD METER SWIVEL NUT x 3/4" MIPT. (NOTE: USE 1" FOR IRRIGATION SERVICE)

1"x7-1/2" SPACER FOR DOMESTIC SERVICE, 1"x10-3/4" SPACER FOR IRRIGATION SERVICE, SPACER SHALL BE FURNISHED BY FAYPWC.

BRICK METER BOX BASE SEE INSET "A"

SECTION "A-A" BRICK METER BOX BASE INSET "A"

FRONT

1"x1"x1" BRASS TEE WITH ONE OR TWO STEP STYLE COMPRESSION FOR 1" TYPE K SOFT COPPER PIPE

1" TYPE K SOFT COPPER PIPE

1" BRASS ELBOW WITH ONE OR TWO STEP STYLE COMPRESSION FOR 1" TYPE K SOFT COPPER PIPE

**NOTES:**

- ALL MATERIALS TO BE APPROVED BY FAYPWC.
- SERVICE LATERAL SIZE 1" TYPE K SOFT COPPER PIPE UNLESS OTHERWISE SPECIFIED.
- WATER SERVICE LOCK VALVE TO BE LOCATED 18" FROM SANITARY SEWER CLEANOUT STACK WHEN INSTALLED IN SAME DITCH.
- WHEN INSTALLED IN A PAVED AREA, METER BOX TO BE SET 1/4" ABOVE FINISHED PAVEMENT GRADES AND PAVEMENT FEATHERED TO TOP OF BOX TO PROVIDE DRAIN AWAY FROM BOX.
- COMPOSITE METER BOXES SHALL BE USED IN TRAFFIC AREAS (SEE PWC DETAIL W.4B)
- INSTALL NCDOT CONCRETE BRICK BASE WITH NO GAPS. DO NOT LAY BRICK ON PIPE. SEE INSET "A".
- WHERE ASPHALT CURB OR STRIP PAVEMENT EXIST, THE LOCATION OF BOX SHALL BE AS DIRECTED BY FAYPWC REPRESENTATIVE.
- DISTANCE FROM TOP OF LOCK VALVE OPERATING STEM TO TOP OF BOX SHALL BE 8" MINIMUM TO 10" MAXIMUM.
- RESIDENTIAL METER BOX SHALL BE SET 18" FROM RIGHT-OF-WAY TO CENTERLINE OF METER BOX PERPENDICULAR TO THE RIGHT-OF-WAY.
- COMMERCIAL METER BOX LOCATION SHALL BE AS APPROVED (PREFER NO METER BE INSTALLED LESS THAN 5' FROM BUILDING TO EDGE OF BOX).
- LATERAL SHALL BE CENTERED ON LOT UNLESS OTHERWISE NOTED.
- LATERAL SHALL NOT BE BACKFILLED UNTIL INSPECTED AND APPROVED BY FAYPWC PROJECT COORDINATOR.
- WATER MAIN AND LATERAL SHALL PASS HYDROSTATIC AND STERILIZATION TESTS.
- SHOULD IT BE NECESSARY TO CRIMP THE WATER SERVICE LATERAL, A FULL CIRCLE REPAIR CLAMP SHALL BE PLACED ON THE CRIMPED AREA.

<b>1" SPLIT WATER SERVICE LATERAL FOR TYPE K SOFT COPPER PIPE</b> N.T.S.		<b>FAYETTEVILLE PUBLIC WORKS COMMISSION</b> FAYETTEVILLE, N.C.		NO.	DATE	REVISION
SHEET NO. 1 OF 2		<b>WATER RESOURCES ENGINEERING DEPARTMENT</b>				
DWG. NO. W.25	DWG. BY: FAYPWC			1	05/05	VALVE CHANGE
DATE: JAN. 01, 2022	APPROVED BY: M.M.M.			2	09/05	VALVE CHANGE, ADD NOTE 17
				3	07/06	ADDED FRONT VIEW AND MOVED NOTES TO SHEET 2

W25-COPPER-SPLIT-WLAT.dwg

**NOTES:**

- ALL MATERIALS TO BE APPROVED BY FAYPWC.
- SERVICE LATERAL SIZE 1" TYPE K SOFT COPPER PIPE UNLESS OTHERWISE SPECIFIED.
- WATER SERVICE LOCK VALVE TO BE LOCATED 18" FROM SANITARY SEWER CLEANOUT STACK WHEN INSTALLED IN SAME DITCH.
- WHEN INSTALLED IN A PAVED AREA, METER BOX TO BE SET 1/4" ABOVE FINISHED PAVEMENT GRADES AND PAVEMENT FEATHERED TO TOP OF BOX TO PROVIDE DRAIN AWAY FROM BOX.
- COMPOSITE METER BOXES SHALL BE USED IN TRAFFIC AREAS (SEE PWC DETAIL W.4B)
- INSTALL NCDOT CONCRETE BRICK BASE WITH NO GAPS. DO NOT LAY BRICK ON PIPE. SEE INSET "A".
- WHERE ASPHALT CURB OR STRIP PAVEMENT EXIST, THE LOCATION OF BOX SHALL BE AS DIRECTED BY FAYPWC REPRESENTATIVE.
- DISTANCE FROM TOP OF LOCK VALVE OPERATING STEM TO TOP OF BOX SHALL BE 8" MINIMUM TO 10" MAXIMUM.
- RESIDENTIAL METER BOX SHALL BE SET 18" FROM RIGHT-OF-WAY TO CENTERLINE OF METER BOX PERPENDICULAR TO THE RIGHT-OF-WAY.
- COMMERCIAL METER BOX LOCATION SHALL BE AS APPROVED (PREFER NO METER BE INSTALLED LESS THAN 5' FROM BUILDING TO EDGE OF BOX).
- LATERAL SHALL BE CENTERED ON LOT UNLESS OTHERWISE NOTED.
- LATERAL SHALL NOT BE BACKFILLED UNTIL INSPECTED AND APPROVED BY FAYPWC PROJECT COORDINATOR.
- WATER MAIN AND LATERAL SHALL PASS HYDROSTATIC AND STERILIZATION TESTS.
- SHOULD IT BE NECESSARY TO CRIMP THE WATER SERVICE LATERAL, A FULL CIRCLE REPAIR CLAMP SHALL BE PLACED ON THE CRIMPED AREA.

<b>NOTES FOR 1" SPLIT WATER SERVICE LATERAL FOR TYPE K SOFT COPPER PIPE</b>		<b>FAYETTEVILLE PUBLIC WORKS COMMISSION</b> FAYETTEVILLE, N.C.		NO.	DATE	REVISION
SHEET NO. 2 OF 2		<b>WATER RESOURCES ENGINEERING DEPARTMENT</b>				
DWG. NO. W.25	DWG. BY: FAYPWC			1	07/06	ADDED FRONT VIEW AND MOVED NOTES TO SHEET 2
DATE: JAN. 01, 2022	APPROVED BY: M.M.M.			2	07/17	REVISED NOTES

W25-COPPER-SPLIT-WLAT.dwg

# PROJECT TYPICAL DETAILS



255 WYCKOFF ROAD  
SUITE 110  
FAYETTEVILLE, NC 28404  
PHONE: 910.891.8889  
NC CCA No. F4602

PROJECT REFERENCE NO.	SHEET NO.
U-2519BA	UC-3G
DESIGNED BY: DJ	
DRAWN BY: DJ	
CHECKED BY: TR	
APPROVED BY: TR	
REVISED:	3/24/2022
UTILITY CONSTRUCTION PLANS ONLY	

## UTILITY CONSTRUCTION

NOTE:  
 ANY REFERENCE TO FAYPWC PROJECT COORDINATOR, PWC COORDINATOR OR FAYPWC (FAYETTEVILLE PUBLIC WORKS COMMISSION) SHALL BE INTERPRETTED AS A REFERENCE TO THE ENGINEER.

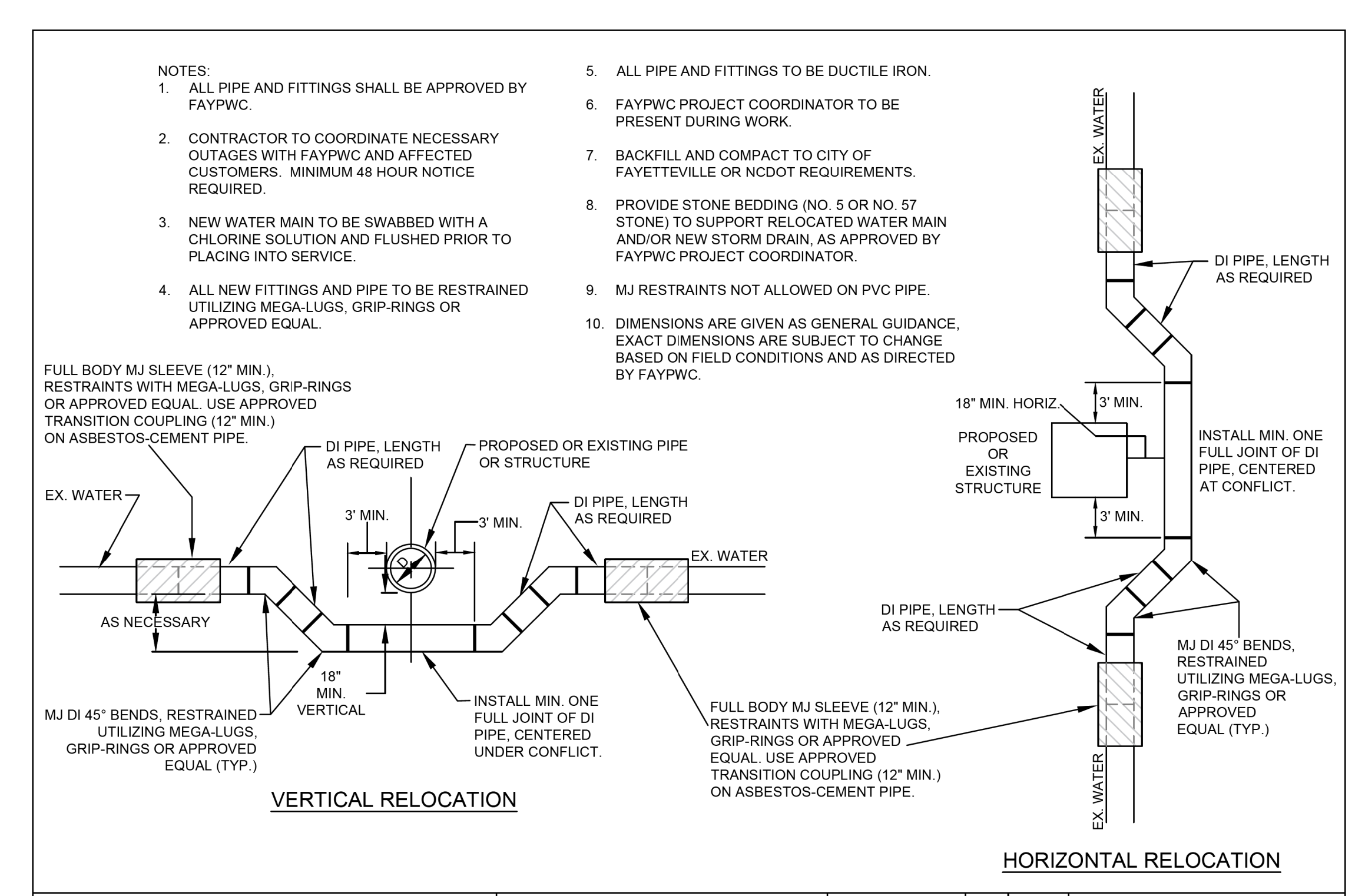

PIPE RELOCATION DETAIL N.T.S.		FAYETTEVILLE PUBLIC WORKS COMMISSION FAYETTEVILLE, N.C.			NO.	DATE	REVISION
SHEET NO. 1 OF 1	DWG. NO.: W.26 DATE: JAN. 01, 2022	DWG. BY: FAYPWC APPROVED BY: M.M.M.	WATER RESOURCES ENGINEERING DEPARTMENT		1	01/12	REVISED NOTES, ADDED HORIZONTAL RELOCATION

W26-PIPE-RELOCATION-DETAIL.dwg

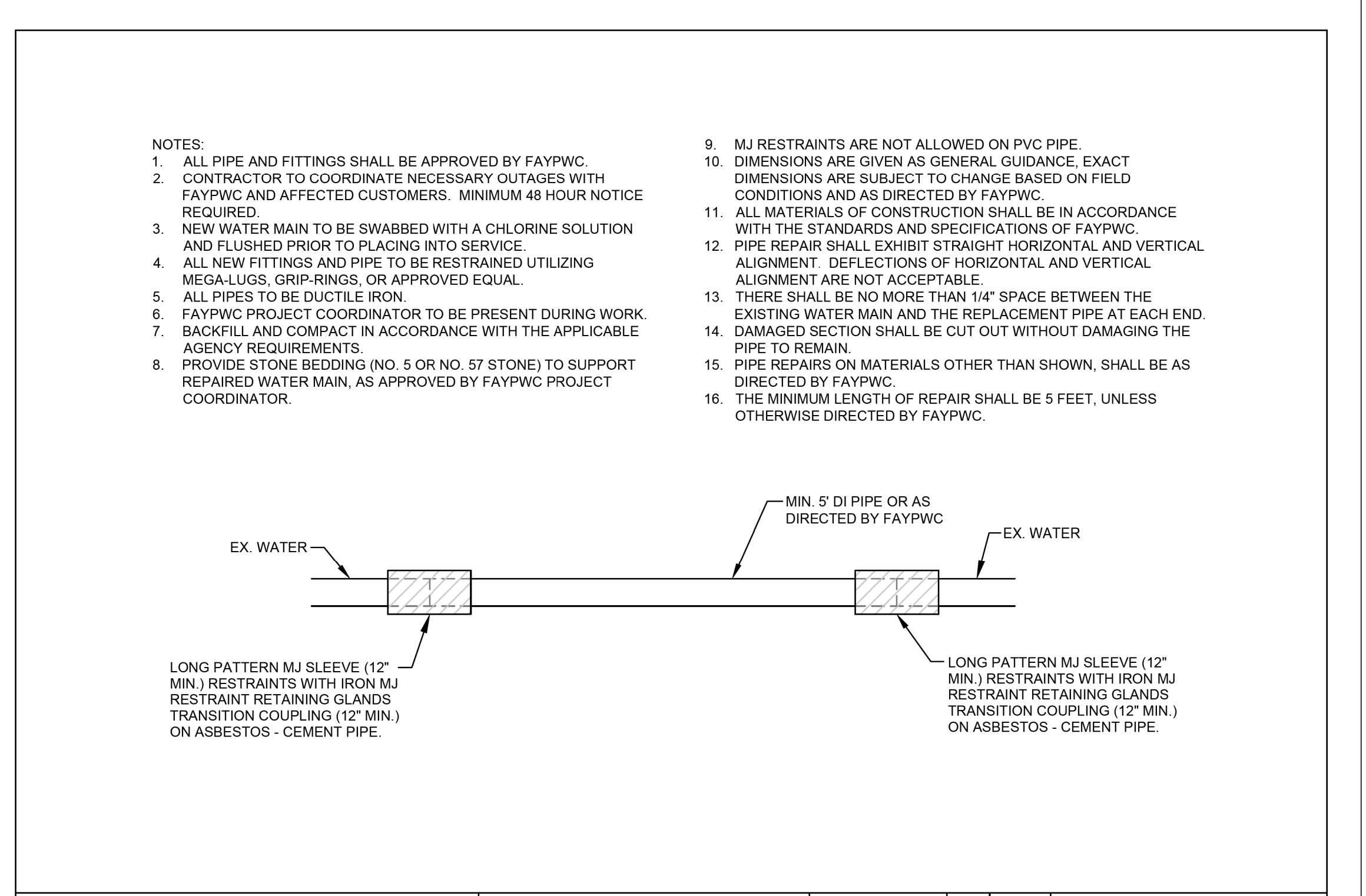

PIPE REPAIR DETAIL N.T.S.		FAYETTEVILLE PUBLIC WORKS COMMISSION FAYETTEVILLE, N.C.			NO.	DATE	REVISION
SHEET NO. 1 OF 1	DWG. NO.: W.31 DATE: JAN. 01, 2022	DWG. BY: FAYPWC APPROVED BY: M.M.M.	WATER RESOURCES ENGINEERING DEPARTMENT				

W31-PIPE-REPAIR-DETAIL.dwg

# PROJECT TYPICAL DETAILS

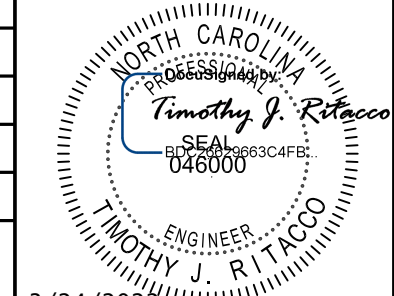
PROJECT REFERENCE NO.	SHEET NO.
U-2519BA	UC-3H
DESIGNED BY: DJ	
DRAWN BY: DJ	
CHECKED BY: TR	
APPROVED BY: TR	
REVISED:	3/24/2022
UTILITY CONSTRUCTION PLANS ONLY	

## UTILITY CONSTRUCTION

NOTE:  
ANY REFERENCE TO FAYPWC PROJECT COORDINATOR, PWC COORDINATOR OR FAYPWC (FAYETTEVILLE PUBLIC WORKS COMMISSION) SHALL BE INTERPRETTED AS A REFERENCE TO THE ENGINEER.

- ALL SEWER MAINS, LATERALS, AND APPURTENANCES SHALL BE INSTALLED AND TESTED IN ACCORDANCE WITH FAYETTEVILLE FAYPWC STANDARDS.
- CONTRACTOR SHALL FIELD VERIFY THE LOCATION OF EXISTING UTILITIES PRIOR TO CONSTRUCTION.
- CONSTRUCTION STAKING IS REQUIRED FOR ALL FAYPWC WATER AND SEWER UTILITY INSTALLATIONS. CUT SHEETS, SIGNED AND SEALED BY A NC PLS, SHALL BE PROVIDED TO THE FAYPWC WATER RESOURCES ENGINEERING DEPARTMENT AND THE CONTRACTOR IN ADVANCE OF CONSTRUCTION FOR FAYPWC WATER AND SEWER UTILITIES.
- CONTRACTOR SHALL MAINTAIN A COPY OF THE SIGNED AND SEALED CUT SHEET ON THE JOB SITE. CONSTRUCTION ON FAYPWC WATER AND SEWER UTILITIES CANNOT BEGIN UNTIL THE CONTRACTOR POSSESSES, ON SITE, A SIGNED AND SEALED CUT SHEET FROM THE PROFESSIONAL LAND SURVEYOR.
- ALL NEW WATER AND SEWER MAINS, LATERALS, AND APPURTENANCES SHALL BE TESTED AND/OR DISINFECTED IN ACCORDANCE WITH FAYETTEVILLE FAYPWC STANDARDS PRIOR TO PLACING INTO SERVICE.
- CONTRACTOR SHALL COORDINATE TESTING AND INSPECTION WITH THE FAYETTEVILLE FAYPWC PROJECT COORDINATOR.
- ALL DUCTILE IRON PIPE IN SANITARY SEWER SERVICE SHALL HAVE AN INTERIOR LINING OF CERAMIC EPOXY.
- ALL NEW MANHOLES ARE TO BE VACUUM-TESTED IN ACCORDANCE WITH FAYETTEVILLE FAYPWC STANDARDS.
- CONTRACTOR SHALL REPAIR ALL SEWER LATERALS AND MAINS DAMAGED DURING CONSTRUCTION. THE CONTRACTOR SHALL IMMEDIATELY REPORT ALL SEWER MAIN AND LATERAL BREAKS TO THE FAYPWC PROJECT COORDINATOR. THE CONTRACTOR SHALL INITIATE IMMEDIATE REPAIRS IN ACCORDANCE WITH FAYPWC STANDARDS.
- TRANSFER OF SEWER SERVICES SHALL BE ACCOMPLISHED AS FOLLOWS:
  - INSTALL AND TEST NEW MAINS, MANHOLES, AND LATERALS. CLEANOUTS SHALL BE INSTALLED 18" INSIDE ROW UNLESS OTHERWISE DIRECTED BY PWC.
  - CONNECT EXISTING PLUMBING TO NEW LATERAL UTILIZING THE NECESSARY FITTINGS AS DIRECTED BY FAYPWC.
  - AFTER ALL SERVICES HAVE BEEN TRANSFERRED TO THE NEW MAIN, THE EXISTING SEWER SYSTEM SHALL BE ABANDONED IN ACCORDANCE WITH FAYPWC REQUIREMENTS.
- CONTRACTOR SHALL ABANDON ("KILL-OUT") ANY EXISTING SEWER SERVICES THAT WILL NOT BE UTILIZED BY UNCOVERING THE EXISTING LATERAL AT THE MAIN, CUT AND PLUG AT BOTH ENDS, REMOVE THE EXISTING CLEANOUT AND COMBINATION, AND PLUG THE TAP OR TEE AT THE MAIN. FOR LATERALS THAT CONNECT TO A MANHOLE AND ARE TO BE ABANDONED ("KILLED-OUT"), THE LATERAL SHALL BE REMOVED FROM THE MANHOLE AND THE REMAINING VOID IN THE MANHOLE SHALL BE FILLED WITH BLOCK AND MORTAR.
- SEWER PLUGS SHALL BE INSTALLED TO ELIMINATE ANY DEBRIS OR OTHER MATERIAL FROM ENTERING THE ACTIVE SEWER SYSTEM. UPON ACCEPTANCE OF THE NEW SEWER SYSTEM, THE CONTRACTOR SHALL CLEAN THE NEW MAINS, REMOVE ALL DEBRIS, AND THEN REMOVE THE PLUG.
- ALL EXISTING UTILITIES IMPACTED BY CONSTRUCTION SHALL BE ADJUSTED TO FINISHED GRADE, IN ACCORDANCE WITH FAYPWC REQUIREMENTS.
- ALL WORK ON FAYPWC SEWER UTILITIES (MAINS, LATERALS, ETC) SHALL BE PERFORMED BY A LICENSED UTILITY CONTRACTOR. THE FAYETTEVILLE PUBLIC WORKS COMMISSION SHALL OBSERVE AND APPROVE ALL WORK ON FAYPWC SEWER UTILITIES. ALL WORK SHALL BE COMPLETED IN ACCORDANCE WITH FAYPWC REQUIREMENTS.

PIPE SIZES	MANHOLE SIZE	MIN. WALL THICKNESS	MIN. REINF. STEEL	MIN. BASE THICKNESS
21" AND LESS	48" DIAMETER	5"	ASTM A-1064 0.12 SQ./IN.	6"
24"-36"	60" DIAMETER	6"	ASTM A-1064 0.15 SQ./IN.	8"
42"	72" DIAMETER	7"	ASTM A-1064 0.15 SQ./IN.	8"

MANHOLE DIAMETER SIZES MAY BE ADJUSTED ON THE PLANS TO REFLECT SPECIAL CIRCUMSTANCES. REDUCING SLABS ARE NOT ACCEPTABLE ON MANHOLES LESS THAN 6' DIAMETER.

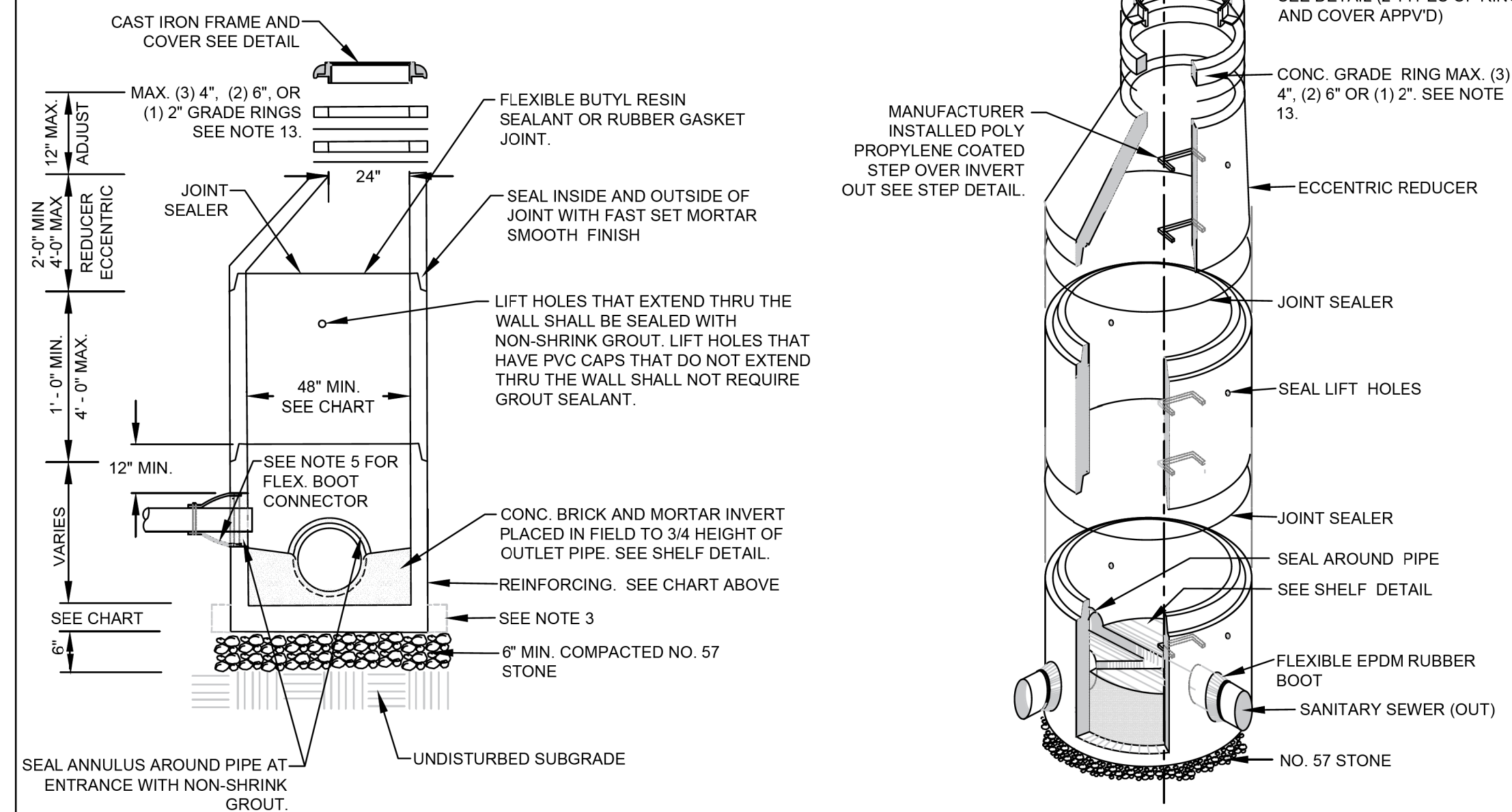

STANDARD MANHOLE N.T.S.			FAYETTEVILLE PUBLIC WORKS COMMISSION FAYETTEVILLE, N.C.		
SHEET NO.	DWG. NO.	DWG. BY:	NO.	DATE	REVISION
1 OF 2	S.2	FAYPWC	1	02/07	CREATED S.2A ADDED NOTES 13-17
			2	07/13	ADDED SHEET 2 OF 2

GENERAL NOTES SANITARY SEWER UTILITY			FAYETTEVILLE PUBLIC WORKS COMMISSION FAYETTEVILLE, N.C.		
SHEET NO.	DWG. NO.	DWG. BY:	NO.	DATE	REVISION
1 OF 1	S.1	FAYPWC	1	07/16	ADDED NOTE 6
			2	01/18	ADDED NOTES 5, 8
			3	06/21	ADDED NOTES 1-8 AND RENUMBERED

- PRECAST REINFORCED CONCRETE MANHOLES SHALL BE IN ACCORDANCE WITH ASTM C-478.
- MINIMUM CONCRETE COMPRESSIVE STRENGTH SHALL BE 4,000PSI.
- MANHOLES GREATER THAN 12' DEPTH SHALL HAVE MINIMUM 6" EXTENDED BASE.
- FLEXIBLE BUTYL RESIN JOINT SEALANT SHALL BE IN ACCORDANCE WITH ASTM C990. RUBBER GASKET JOINTS SHALL BE IN ACCORDANCE WITH ASTM C-443.
- FLEXIBLE EPDM RUBBER BOOT CONNECTORS SHALL BE IN ACCORDANCE WITH ASTM C923. INSTALLED BY MANUFACTURER WITH STAINLESS STEEL COMPRESSION RING AND TAKE-UP CLAMP. CONNECTION TO MAIN SHALL BE BY CONTRACTOR WITH STAINLESS STEEL PIPE CLAMP.
- CONNECTIONS TO EXISTING MANHOLES SHALL BE BY CORING MANHOLE AND FIELD INSTALLING A FLEXIBLE EPDM RUBBER BOOT CONNECTOR. DO NOT ALLOW DEBRIS TO ENTER SYSTEM.
- MORTAR SHALL BE QUICK SETTING, NON-SHRINK GROUT MIXED IN ACCORDANCE WITH MANUFACTURER'S RECOMMENDATIONS.
- MANHOLE STEPS SHALL BE IN ACCORDANCE WITH ASTM C478 AND OSHA REGULATIONS. ALIGN STEPS WITH INVERT OUT.
- PRECAST INVERTS ARE NOT ALLOWED.
- VERTICAL DROPS BETWEEN THE INFLOW PIPES AND OUTFLOW PIPES SHALL REQUIRE THE FOLLOWING:
  - GREATER THAN 2.5' SEE DROP STRUCTURE DETAIL (MIN. 5' DIAMETER MH REQUIRED).
  - LESS THAN 2.5' SEE PIPE SLIDE DETAIL.
- AN ECCENTRIC CONE SHALL BE UTILIZED ON ALL MANHOLES, UNLESS OTHERWISE APPROVED BY FAYPWC.
- INVERT ON PLANS IS TO MANHOLE CENTERLINE.
- CONCRETE GRADE RINGS SHALL NOT BE USED FOR ABOVE GRADE ADJUSTMENTS (IE: OUTFALL AREAS). USE OF GRADE RINGS ARE ALLOWABLE IN YARD AREAS AND PAVEMENT, WHERE THE RING AND COVER ARE AT GROUND LEVEL.
- THE MINIMUM SLOPE ACROSS THE INVERT OF THE MANHOLE SHALL BE 1%, UNLESS OTHERWISE APPROVED BY FAYPWC. STANDING WATER IN INVERT OF MANHOLE IS NOT ACCEPTABLE.
- THE EXTERIOR MANHOLE RISER JOINTS, INCLUDING THE JOINT AT THE CONE, SHALL BE SEALED ON THE OUTSIDE BY AN APPROVED JOINT WRAP. THE WRAP SHALL BE IN ACCORDANCE WITH FAYPWC SPECIFICATIONS.
- MANHOLE BOOT FOR 4-INCH LATERALS, SHOULD IT BE NECESSARY TO INSTALL A 4-INCH LATERAL INTO A MANHOLE, THE RUBBER BOOT THAT THE LATERAL IS INSERTED INTO SHALL BE SECURELY FASTENED TO THE CORE HOLE BY UTILIZING A STAINLESS STEEL BAND THAT IS TIGHTENED USING A JACK OR A TORQUE WRENCH (DIRECT DRIVE). BOTH STANDARD SIZE AND STEP DOWN BOOTS ARE ALLOWED. THE TORQUE WRENCH SHALL BE SUPPLIED BY THE MANUFACTURER. NO OTHER TYPE BANDS OR METHOD OF SECURING THE BOOT TO THE MANHOLE SHALL BE ACCEPTED.

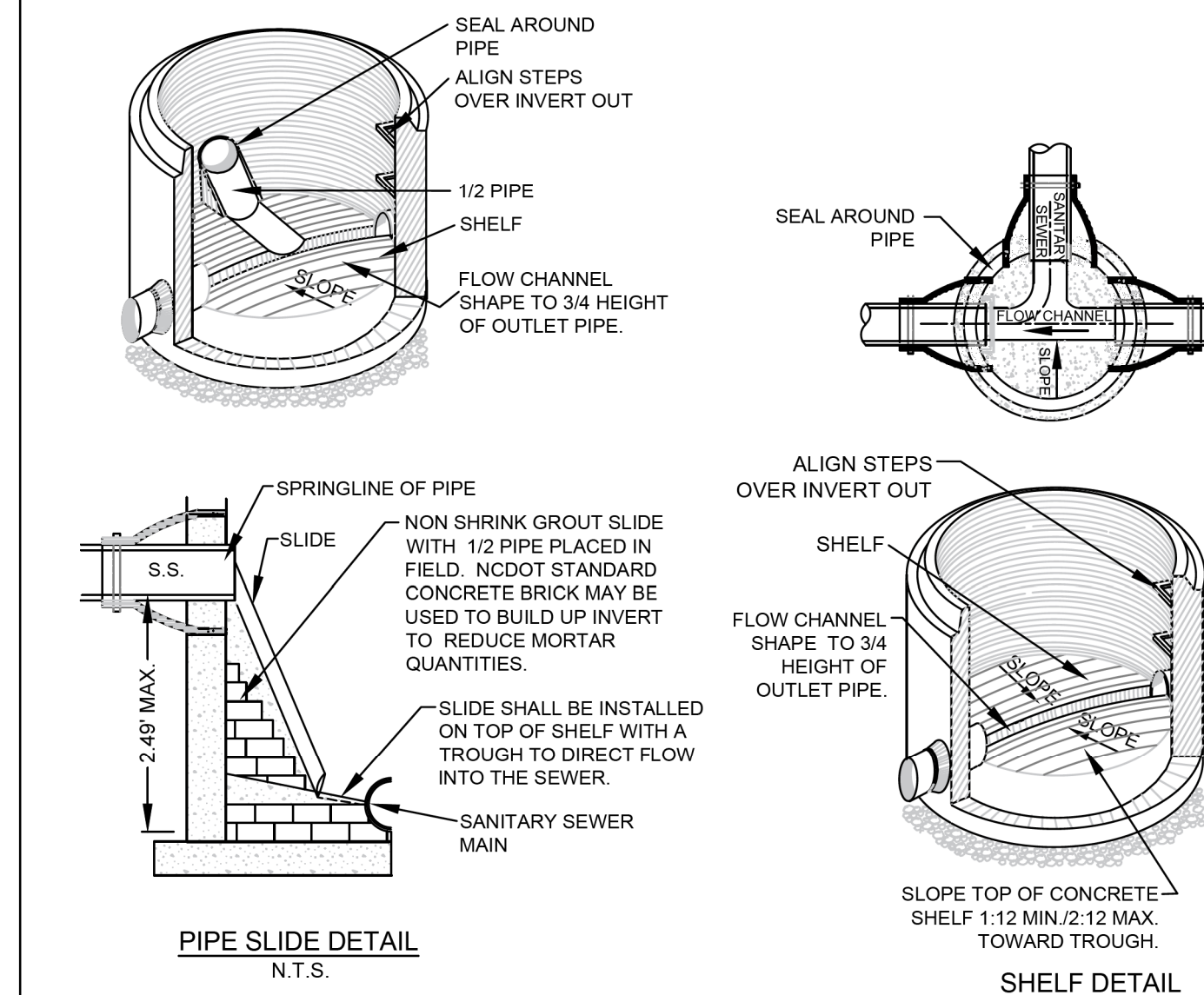

- PIPE SLIDE REQUIRED WHERE VERTICAL SEPARATION BETWEEN PIPE INVERTS IS LESS THAN 2.5'. FOR LATERAL INVERTS AT OR WITHIN FOUR (4) INCHES OF THE SHELF, CONSTRUCT BENCH AND INVERT AS DIRECTED BY THE FAYPWC PROJECT COORDINATOR.
- INTERIOR DROP STRUCTURE REQUIRED WHERE VERTICAL SEPARATION BETWEEN INVERTS EQUALS OR EXCEEDS 2.50'. FOR INTERIOR DROP STRUCTURE SEE FAYPWC DETAIL S.5.
- VERIFY SLIDE INSTALLATION WITH PROJECT COORDINATOR PRIOR TO CONSTRUCTION.
- MANHOLE AND CONNECTIONS SHALL BE IN ACCORDANCE WITH FAYPWC REQUIREMENTS.
- BRICK USED FOR INVERT AND SHELF CONSTRUCTION SHALL BE NCDOT STANDARD CONCRETE BRICK.
- MANHOLES GREATER THAN 12' IN DEPTH SHALL HAVE MINIMUM 6" EXTENDED BASE.
- THE MINIMUM SLOPE ACROSS THE INVERT OF THE MANHOLE SHALL BE 1% UNLESS OTHERWISE APPROVED BY FAYPWC.
- DROP AND/OR SLIDE REQUIREMENTS SHALL APPLY TO ALL LATERALS ENTERING MANHOLES AS OUTLINED IN NOTES 1, 2, AND 3. NO MORE THAN 4, FOUR INCH LATERALS OR 3, SIX INCH LATERALS SHALL ENTER A 4' DIAMETER TERMINAL MANHOLE. NO MORE THAN 2 LATERALS (REGARDLESS OF SIZE) SHALL ENTER ALL OTHER 4' DIAMETER MANHOLES. ALL LATERALS SHALL HAVE AN INDIVIDUAL TROUGH. 5' DIAMETER MANHOLES SHALL BE USED IF THE ABOVE CONDITIONS ARE NOT MET. THE INVERT OF THE LATERAL SHALL BE A MINIMUM OF 1" ABOVE THE SHELF.
- NO MORE THAN 5 LATERALS SHALL ENTER A 5' DIAMETER TERMINAL MANHOLE.
- USE OF TEE-WYES ON LATERALS IS NOT ALLOWED.

STANDARD MANHOLE			FAYETTEVILLE PUBLIC WORKS COMMISSION FAYETTEVILLE, N.C.		
SHEET NO.	DWG. NO.	DWG. BY:	NO.	DATE	REVISION
2 OF 2	S.2	FAYPWC	1	01/08	CREATED DETAIL, ADDED NOTES 14-20
			2	07/13	REVISED NOTES 9, 10, 11, 15. CONVERTED TO S.2 SHEET 2 OF 2
			3	01/01/19	REVISED NOTES 10, 18

PIPE SLIDE AND SHELF DETAILS N.T.S.			FAYETTEVILLE PUBLIC WORKS COMMISSION FAYETTEVILLE, N.C.		
SHEET NO.	DWG. NO.	DWG. BY:	NO.	DATE	REVISION
1 OF 1	S.4	FAYPWC	1	01/05	ADDED NOTE 8
			2	02/07	REVISED NOTE 8, SLIDE DETAIL, ADDED NOTES 10, 11, 12
			3	01/18	DELETED MORTAR SLIDE, REVISED NOTES

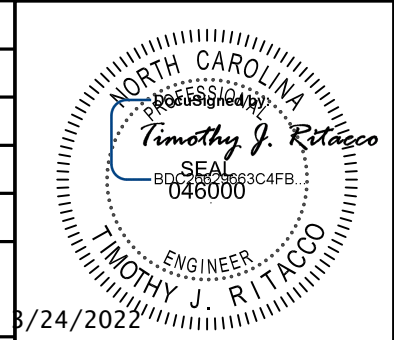
PROJECT REFERENCE NO.	SHEET NO.
U-2519BA	UC-3K
DESIGNED BY: DJ	
DRAWN BY: DJ	
CHECKED BY: TR	
APPROVED BY: TR	
REVISED:	3/24/2022
UTILITY CONSTRUCTION PLANS ONLY	

# UTILITY CONSTRUCTION

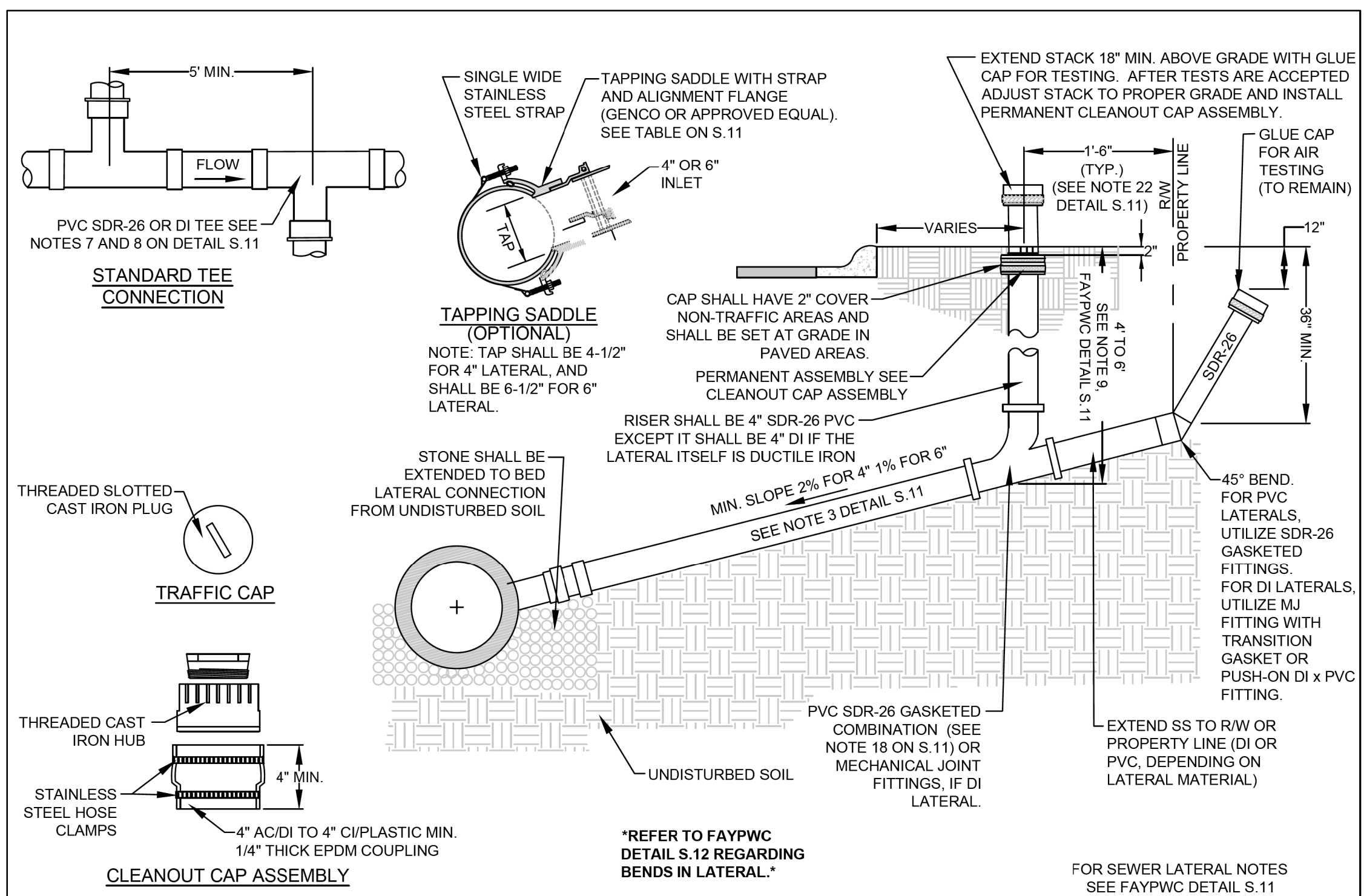

SEWER LATERAL (4-INCH AND 6-INCH) N.T.S.		FAYETTEVILLE PUBLIC WORKS COMMISSION FAYETTEVILLE, N.C.			NO.	DATE	REVISION
SHEET NO. 1 OF 1	DWG. NO. S.10	DWG. BY: FAYPWC	WATER RESOURCES ENGINEERING DEPARTMENT		2	01/14	ADDED TAILPIECE, NOTES
DATE: JAN. 01, 2022	APPROVED BY: M.M.M.			3	01/15	REVISED NOTES RE: TAILPIECE	
				4	07/18	REVISED NOTE RE: LATERAL DEPTH	

S10-RESSLAT.dwg

## SEWER LATERAL NOTES

- HOLE IN SANITARY SEWER MAIN MUST BE CUT WITH SHELL CUTTER NO HAMMER TAPS ALLOWED.
- LATERAL SHALL CONFORM TO ASTM SPECS. D-3034 SDR-26 UNLESS OTHERWISE INDICATED AS DI.
- ALL PIPE AND FITTINGS SHALL BE 4" OR 6" UNLESS OTHERWISE SPECIFIED.
- ALL DI PIPE SHALL HAVE AN INTERIOR LINING OF CERAMIC EPOXY (PROTECTO 401). THE ENTIRE DI LATERAL SHALL BE COMPRISED OF DI PIPE AND MECHANICAL JOINT FITTINGS.
- ALL CONNECTIONS SHALL HAVE RUBBER GASKET SEALS INSTALLED.
- SANITARY SEWER LATERAL CLEANOUT STACK SHALL BE LOCATED 18" FROM WATER LATERAL LOCK VALVE WHEN IN THE SAME DITCH.
- INSTALLATION OTHER THAN AS SHOWN MUST BE APPROVED BY THE FAYPWC.
- CONNECTIONS TO THE TOP OF MAIN SHALL NOT BE ALLOWED UNLESS OTHERWISE APPROVED BY THE FAYPWC PROJECT COORDINATOR.
- THE DESIGN ENGINEER SHALL DETERMINE THE SLOPE AND DEPTH OF THE LATERAL BASED ON THE TOPOGRAPHY OF THE LOT.
- LATERAL SHALL CONFORM TO 2% MINIMUM SLOPE FOR 4" OR 1% MINIMUM SLOPE FOR 6". THE MAXIMUM LENGTH OF A SEWER LATERAL SHALL BE 60 FEET, UNLESS OTHERWISE APPROVED BY FAYPWC.
- SEE INTERIOR DROP STRUCTURE OR SLIDE, MORTAR SLIDE AND SHELF DETAIL FOR VERTICAL DROPS OF MAINS AND LATERALS.
- LATERALS LESS THAN 3' IN DEPTH OR GREATER THAN 20' DEPTH SHALL UTILIZE DUCTILE IRON PIPE AND FITTINGS WITH CERAMIC EPOXY (PROTECTO 401), OR WHEN SEPARATION REQUIREMENTS CANNOT BE MET.
- ENTIRE SEWER LATERAL ASSEMBLY SHALL BE AIR TESTED CONCURRENTLY WITH SEWER MAIN.
- INDIVIDUAL LATERALS SHALL BE CLEANED AND FLUSHED PRIOR TO FLUSHING SANITARY SEWER MAINS.
- LATERAL SHALL NOT BE BACK-FILLED UNTIL INSPECTED BY THE FAYPWC PROJECT COORDINATOR.
- WYE CONNECTIONS SHALL NOT BE USED TO TIE LATERALS INTO A MANHOLE.
- IF BENDS ARE APPROVED BY THE PROJECT COORDINATOR, STONE BEDDING IS REQUIRED TO BE INSTALLED FROM UNDISTURBED (SEE DETAIL S.12) SOIL TO BOTTOM OF BEND.
- PVC COMBINATION SHALL BE A MOLDED WYE AND BEND, GASKETED, SDR-26, AS MANUFACTURED BY HARCO, GPK, PLASTIC TRENDS, OR APPROVED EQUAL.
- NO MORE THAN 4, FOUR-INCH LATERALS OR 3, SIX-INCH LATERALS SHALL ENTER A 4' DIAMETER TERMINAL MANHOLE. NO MORE THAN 2 LATERALS (REGARDLESS OF SIZE) SHALL ENTER ALL OTHER 4' DIAMETER MANHOLES. ALL LATERALS SHALL HAVE AN INDIVIDUAL TROUGH. 5' DIAMETER MANHOLES SHALL BE USED IF THE ABOVE CONDITIONS ARE NOT MET.
- ALL LATERALS (4" AND 6") SHALL UTILIZE A 4" RISER (STACK).
- REFER TO DETAIL S.12 FOR SEPARATION REQUIREMENTS.
- FOR SINGLE FAMILY RESIDENTIAL LOTS, CLEANOUT SHALL BE LOCATED 18" FROM RIGHT-OF-WAY OR EASEMENT. FOR ALL NON-SINGLE FAMILY LOTS, CLEANOUT SHALL BE NO CLOSER THAN 10' TO FRONT OF BUILDING, UNLESS OTHERWISE APPROVED BY FAYPWC.

THE FOLLOWING TABLE SUMMARIZES THE MATERIALS TO BE UTILIZED FOR SEWER MAIN TO LATERAL CONNECTIONS:

	PVC Main	DI Main
DI Lateral	DI fitting or approved saddle	MJ fitting or approved saddle
PVC Lateral	PVC fitting or approved saddle	MJ fitting with transition gasket or approved saddle

NOTE: REFER TO FAYPWC TECHNICAL SPECIFICATIONS FOR ADDITIONAL INFORMATION.

SEWER LATERAL NOTES (4-INCH AND 6-INCH)		FAYETTEVILLE PUBLIC WORKS COMMISSION FAYETTEVILLE, N.C.			NO.	DATE	REVISION
SHEET NO. 1 OF 1	DWG. NO. S.11	DWG. BY: FAYPWC	WATER RESOURCES ENGINEERING DEPARTMENT		3	01/13	REVISED NOTES AND ADDED TABLE
DATE: JAN. 01, 2022	APPROVED BY: M.M.M.			4	01/15	REVISED NOTE 22, TABLE	
				5	07/18	REVISED NOTES 6, 9	

S11-RESSLAT-NOTES.dwg

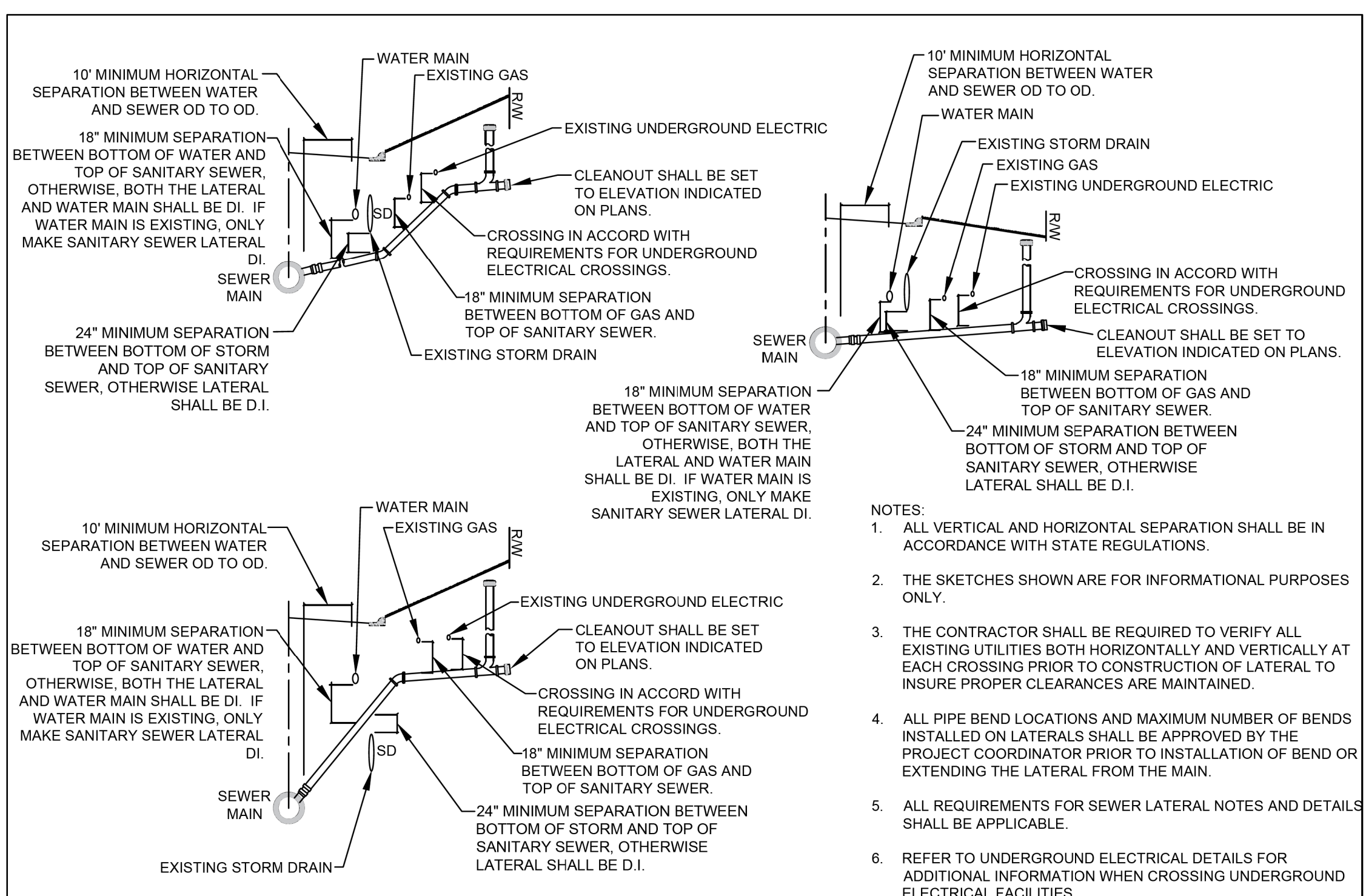

SEWER LATERAL UTILITY CONFLICT SEPARATION REQUIREMENTS N.T.S.		FAYETTEVILLE PUBLIC WORKS COMMISSION FAYETTEVILLE, N.C.			NO.	DATE	REVISION
SHEET NO. 1 OF 1	DWG. NO. S.12	DWG. BY: FAYPWC	WATER RESOURCES ENGINEERING DEPARTMENT		1	01/05	REVISED NOTES 1 AND 6
DATE: JAN. 01, 2022	APPROVED BY: M.M.M.			2	11/06	ADDED NOTE ON DI LATERALS	
				3	03/10	ADDED LATERAL AND WM SEPARATION	

S12-UTIL-CONFLICT.dwg

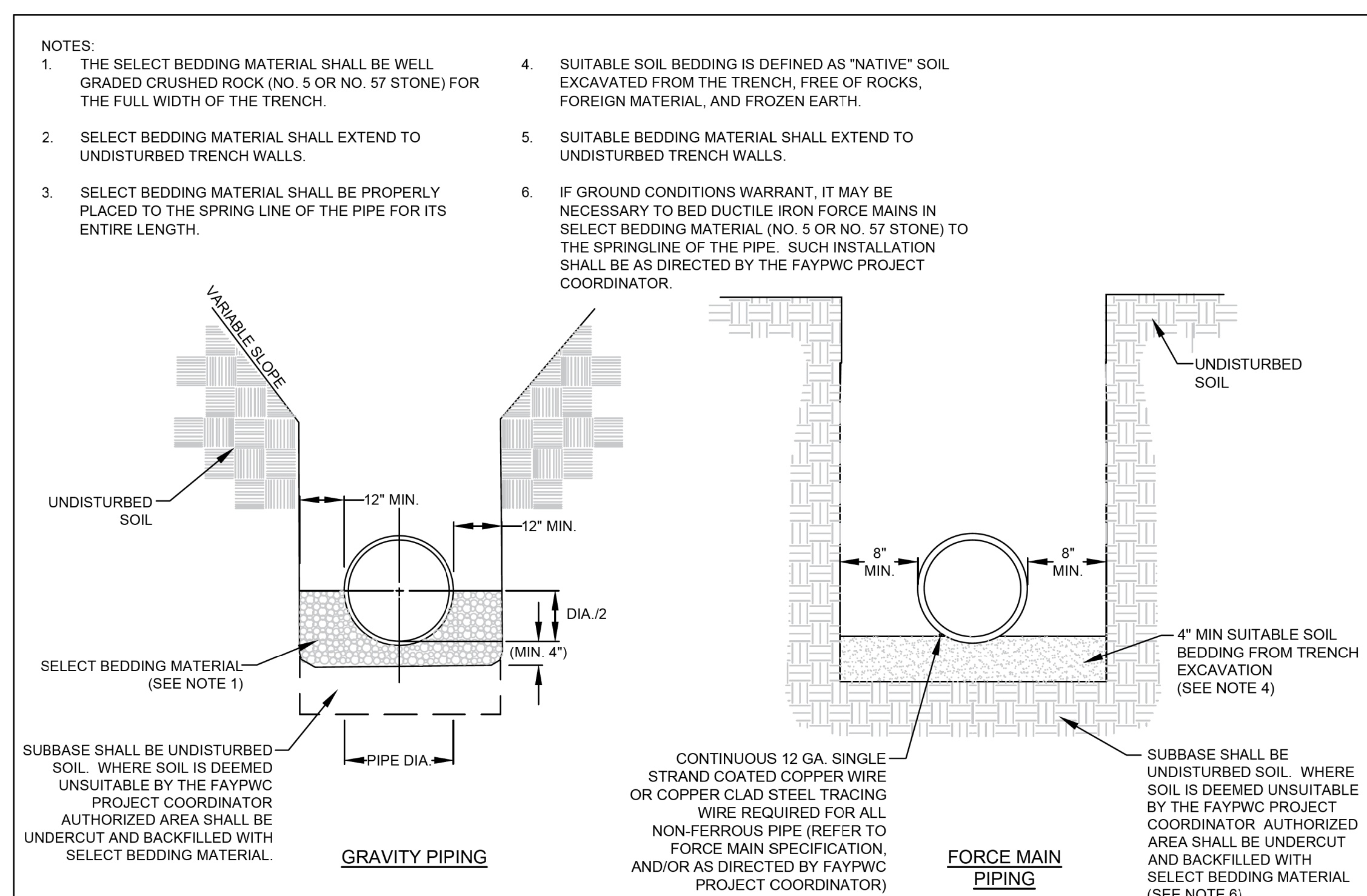

SEWER BEDDING N.T.S.		FAYETTEVILLE PUBLIC WORKS COMMISSION FAYETTEVILLE, N.C.			NO.	DATE	REVISION
SHEET NO. 1 OF 1	DWG. NO. S.13	DWG. BY: FAYPWC	WATER RESOURCES ENGINEERING DEPARTMENT		1	01/01/05	REVISED NOTES
DATE: JAN. 01, 2022	APPROVED BY: M.M.M.			2	01/01/16	REVISED NOTES	

S13-SEWER-BEDDING.dwg

24-MAR-2022 10:37 AM C:\CAD\CAD\Utilities\Engineer\ng\UC\Pro\280\_025\_U2519BA\_UT\_DTL\_UC3K\_PSH.dgn

# PROJECT TYPICAL DETAILS



2411 W. 2002nd St.  
 Fayetteville, NC 28404  
 Phone: 910.881.3889  
 Fax: 910.881.3888

PROJECT REFERENCE NO.	SHEET NO.
U-2519BA	UC-3J
DESIGNED BY: DJ	
DRAWN BY: DJ	
CHECKED BY: TR	
APPROVED BY: TR	
REVISED:	3/24/2022
UTILITY CONSTRUCTION PLANS ONLY	

## UTILITY CONSTRUCTION

**NOTE:**  
 ANY REFERENCE TO FAYPWC PROJECT COORDINATOR, PWC COORDINATOR OR FAYPWC (FAYETTEVILLE PUBLIC WORKS COMMISSION) SHALL BE INTERPRETED AS A REFERENCE TO THE ENGINEER.

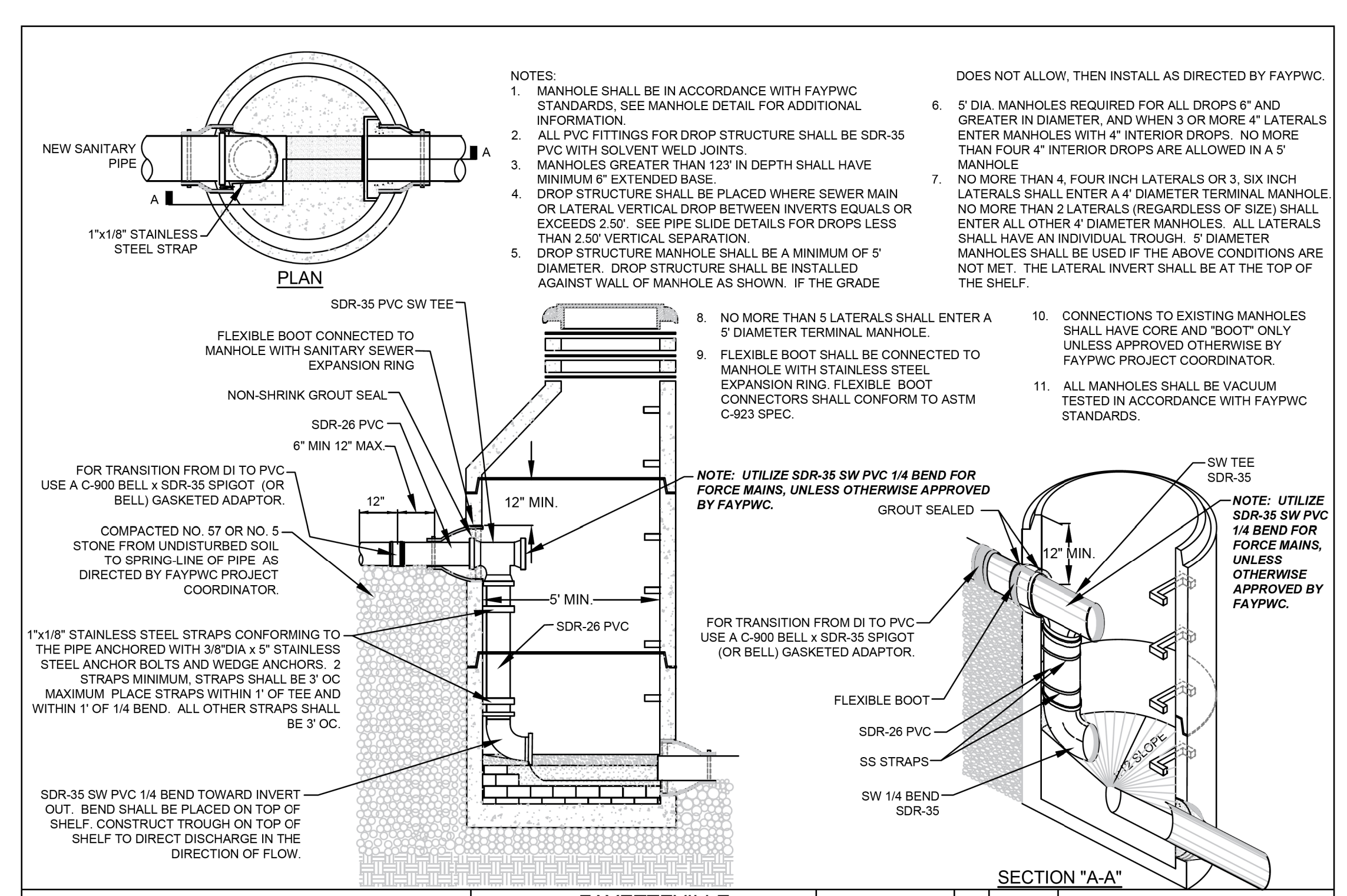

INTERIOR DROP STRUCTURE SEWER MAINS AND LATERALS		FAYETTEVILLE PUBLIC WORKS COMMISSION FAYETTEVILLE, N.C.		NO. DATE REVISION	
SHEET NO. 1 OF 1		DWG. NO. S.5 DWG. BY: FAYPWC		4 11/08 REVISED FITTING MATERIAL	
DATE: JAN. 01, 2022		APPROVED BY: M.M.M.		5 07/12 REVISED NOTES 5, 6, AND HUB ON INVERT	
WATER RESOURCES ENGINEERING DEPARTMENT		FAYETTEVILLE PUBLIC WORKS COMMISSION FAYETTEVILLE, N.C.		6 07/14 ADDED FORCE MAIN NOTE	
SS-DROP-MH.dwg					

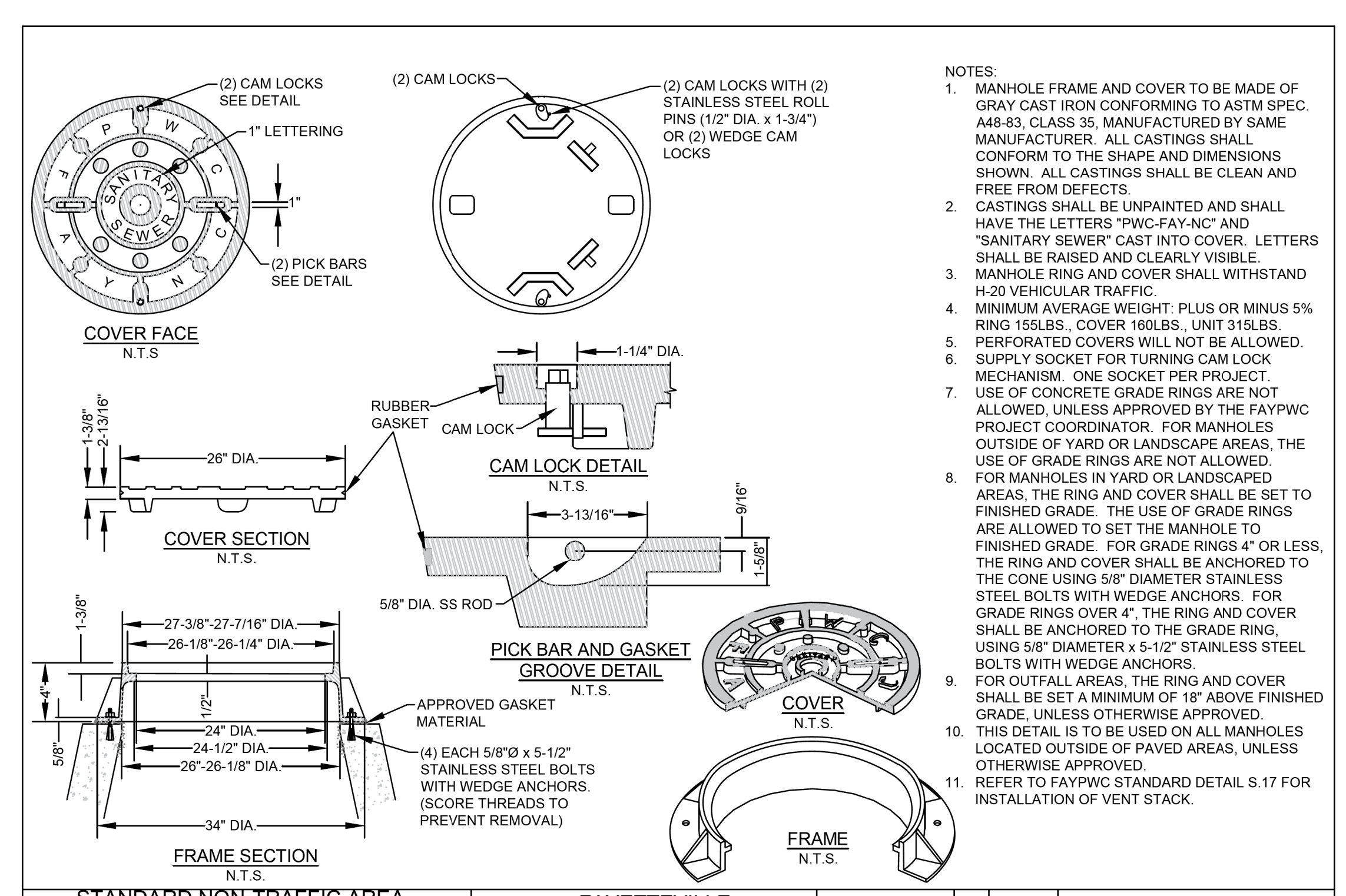

STANDARD NON-TRAFFIC AREA MANHOLE RING AND COVER WITH WIPER GASKET AND CAM LOCK		FAYETTEVILLE PUBLIC WORKS COMMISSION FAYETTEVILLE, N.C.		NO. DATE REVISION	
SHEET NO. 1 OF 1		DWG. NO. S.6 DWG. BY: FAYPWC		1 07/09 REVISED NOTES ON FRAME SECTION/REVISED NOTE 3	
DATE: JAN. 01, 2022		APPROVED BY: M.M.M.		2 07/17 ADDED NOTE ON WEDGE CAM LOCKS	
WATER RESOURCES ENGINEERING DEPARTMENT		FAYETTEVILLE PUBLIC WORKS COMMISSION FAYETTEVILLE, N.C.		3 01/18 UPDATED NOTES 7 AND 8	
S6-RING-COVER.dwg					

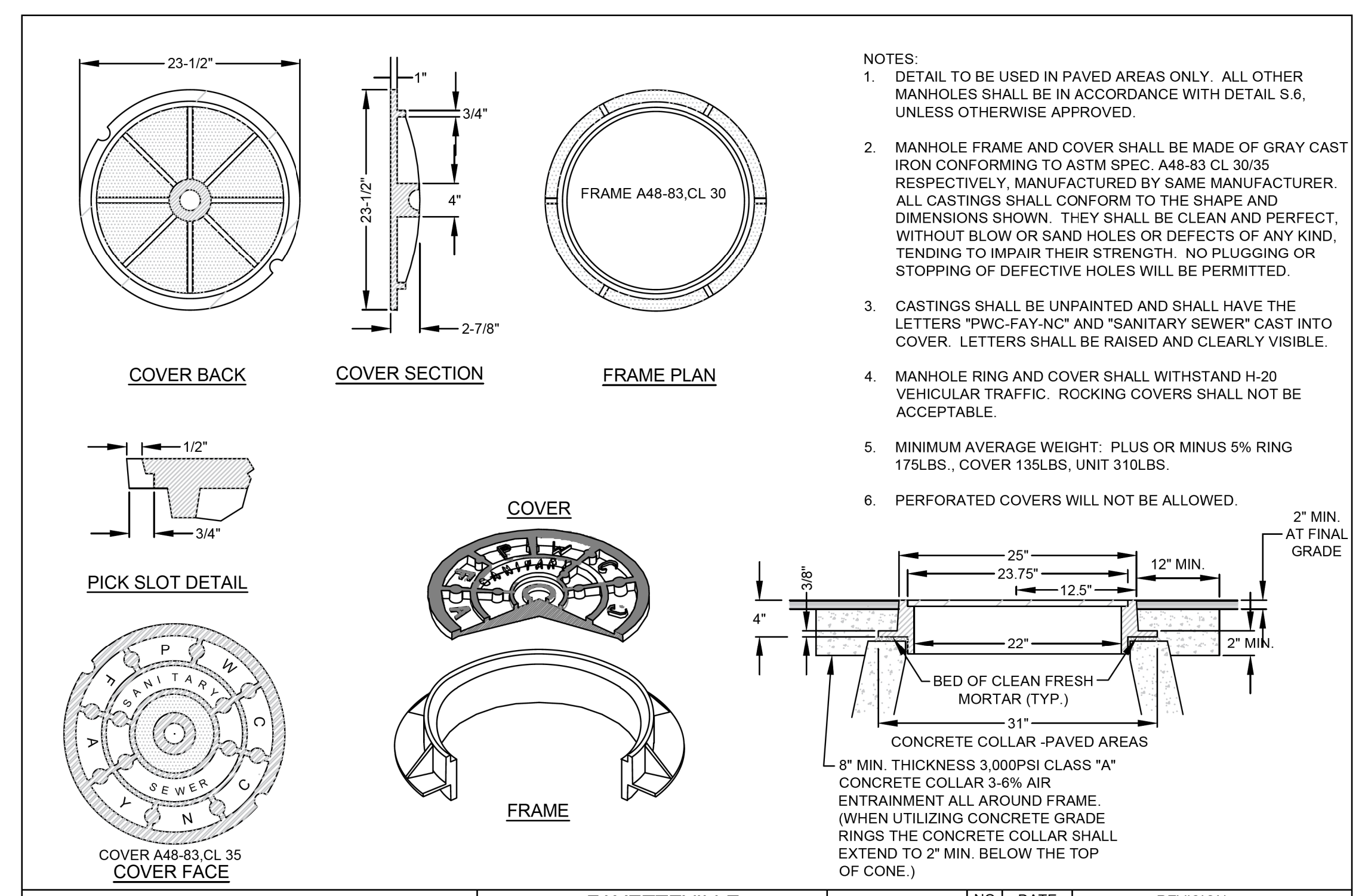

STANDARD TRAFFIC AREA MANHOLE RING AND COVER		FAYETTEVILLE PUBLIC WORKS COMMISSION FAYETTEVILLE, N.C.		NO. DATE REVISION	
SHEET NO. 1 OF 1		DWG. NO. S.7 DWG. BY: FAYPWC		1 01/05 CHANGED NON TRAFFIC DETAIL	
DATE: JAN. 01, 2022		APPROVED BY: M.M.M.		2 07/06 ADDED NOTE ON CONCRETE COLLAR	
WATER RESOURCES ENGINEERING DEPARTMENT		FAYETTEVILLE PUBLIC WORKS COMMISSION FAYETTEVILLE, N.C.		3 02/07 REMOVED NON TRAFFIC AREA AND REVISED NOTES	
				4 07/08 REVISED ASPHALT THICKNESS	
S7-RING-COVER.dwg					

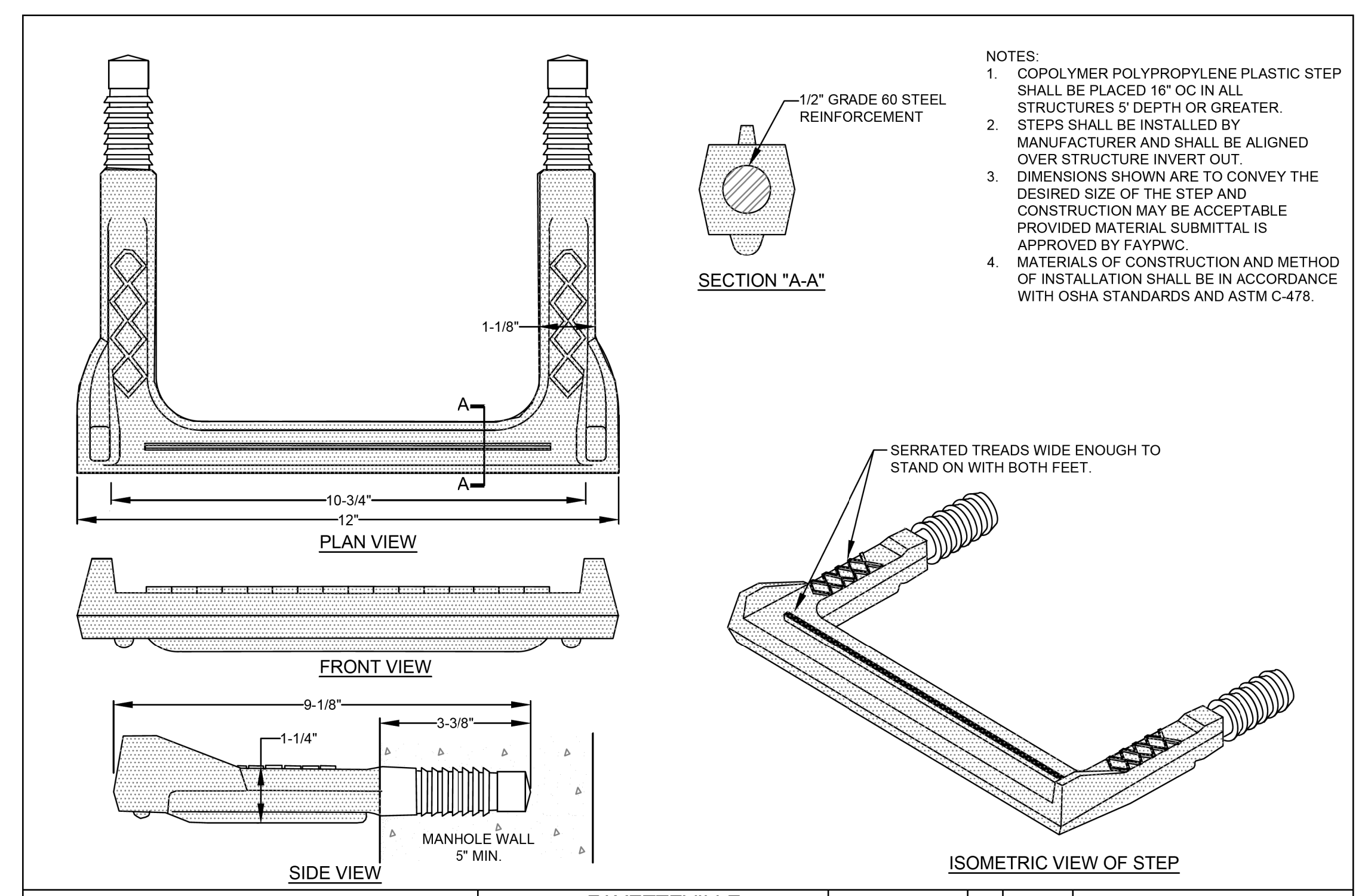

STRUCTURE STEP		FAYETTEVILLE PUBLIC WORKS COMMISSION FAYETTEVILLE, N.C.		NO. DATE REVISION	
SHEET NO. 1 OF 1		DWG. NO. S.8 DWG. BY: FAYPWC			
DATE: JAN. 01, 2022		APPROVED BY: M.M.M.			
WATER RESOURCES ENGINEERING DEPARTMENT		FAYETTEVILLE PUBLIC WORKS COMMISSION FAYETTEVILLE, N.C.			
S8-STEP.dwg					

5/14/22



2500 W. JEFFERSON ROAD  
SUITE 110  
FAYETTEVILLE, NC 28404  
PHONE: 910.891.9999  
NC COLA #24000

PROJECT REFERENCE NO.	SHEET NO.
U-2519BA	UC-3K
DESIGNED BY: DJ	
DRAWN BY: DJ	
CHECKED BY: TR	
APPROVED BY: TR	
REVISED:	3/24/2022
UTILITY CONSTRUCTION PLANS ONLY	

# UTILITY CONSTRUCTION

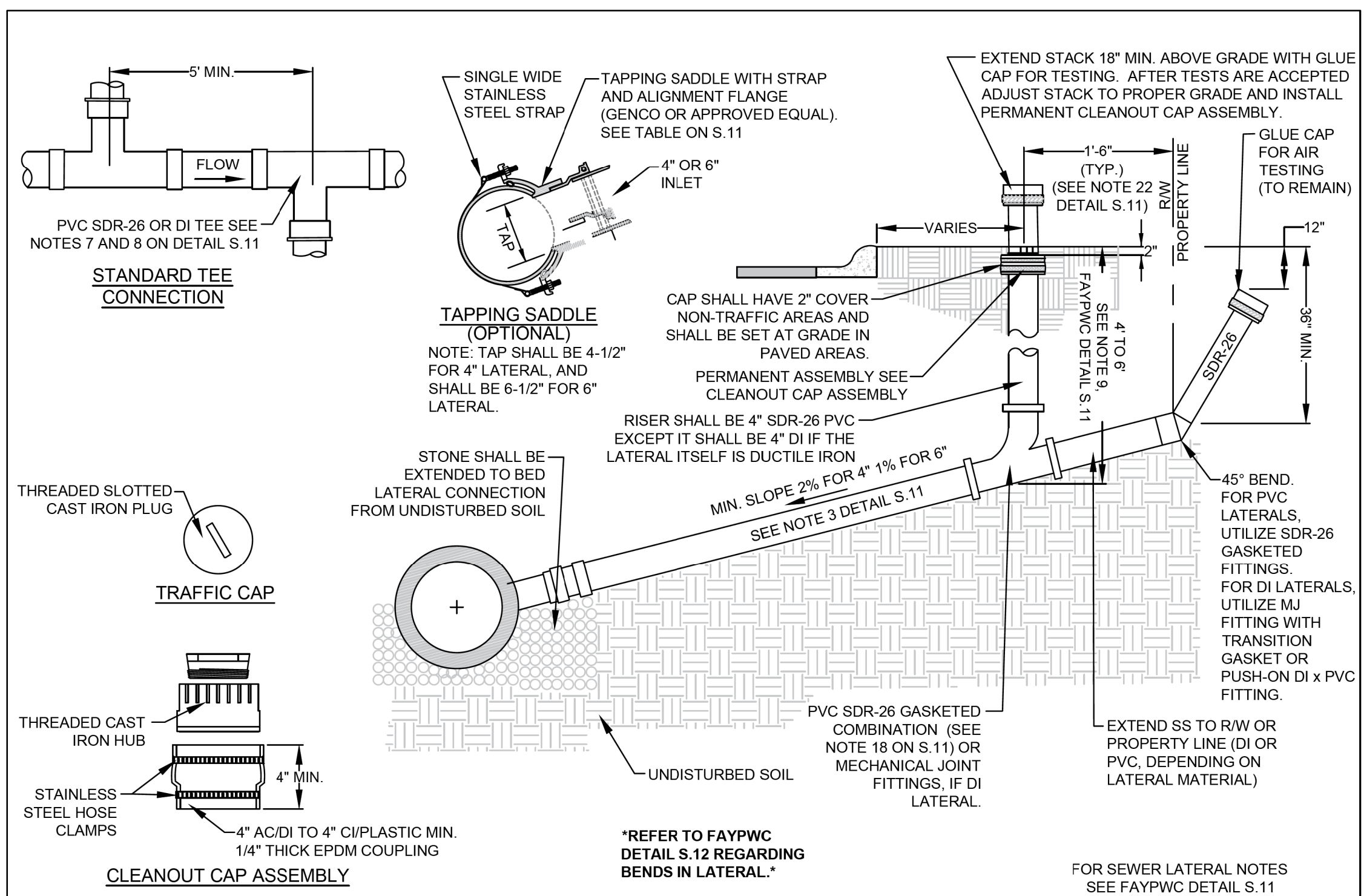

SEWER LATERAL (4-INCH AND 6-INCH) N.T.S.		FAYETTEVILLE PUBLIC WORKS COMMISSION FAYETTEVILLE, N.C.		NO.	DATE	REVISION
DWG. NO. S.10		WATER RESOURCES ENGINEERING DEPARTMENT				
SHEET NO. 1 OF 1	DATE: JAN. 01, 2022	DWG. BY: FAYPWC	APPROVED BY: M.M.M.	2	01/14	ADDED TAILPIECE, NOTES
				3	01/15	REVISED NOTES RE: TAILPIECE
				4	07/18	REVISED NOTE RE: LATERAL DEPTH

S10-RESSLAT.dwg

## SEWER LATERAL NOTES

- HOLE IN SANITARY SEWER MAIN MUST BE CUT WITH SHELL CUTTER NO HAMMER TAPS ALLOWED.
- LATERAL SHALL CONFORM TO ASTM SPECS. D-3034 SDR-26 UNLESS OTHERWISE INDICATED AS DI.
- ALL PIPE AND FITTINGS SHALL BE 4" OR 6" UNLESS OTHERWISE SPECIFIED.
- ALL DI PIPE SHALL HAVE AN INTERIOR LINING OF CERAMIC EPOXY (PROTECTO 401). THE ENTIRE DI LATERAL SHALL BE COMPRISED OF DI PIPE AND MECHANICAL JOINT FITTINGS.
- ALL CONNECTIONS SHALL HAVE RUBBER GASKET SEALS INSTALLED.
- SANITARY SEWER LATERAL CLEANOUT STACK SHALL BE LOCATED 18" FROM WATER LATERAL LOCK VALVE WHEN IN THE SAME DITCH.
- INSTALLATION OTHER THAN AS SHOWN MUST BE APPROVED BY THE FAYPWC.
- CONNECTIONS TO THE TOP OF MAIN SHALL NOT BE ALLOWED, UNLESS OTHERWISE APPROVED BY THE FAYPWC PROJECT COORDINATOR.
- THE DESIGN ENGINEER SHALL DETERMINE THE SLOPE AND DEPTH OF THE LATERAL BASED ON THE TOPOGRAPHY OF THE LOT.
- LATERAL SHALL CONFORM TO 2% MINIMUM SLOPE FOR 4" OR 1% MINIMUM SLOPE FOR 6". THE MAXIMUM LENGTH OF A SEWER LATERAL SHALL BE 60 FEET, UNLESS OTHERWISE APPROVED BY FAYPWC.
- SEE INTERIOR DROP STRUCTURE OR SLIDE, MORTAR SLIDE AND SHELF DETAIL FOR VERTICAL DROPS OF MAINS AND LATERALS.
- LATERALS LESS THAN 3' IN DEPTH OR GREATER THAN 20' DEPTH SHALL UTILIZE DUCTILE IRON PIPE AND FITTINGS WITH CERAMIC EPOXY (PROTECTO 401), OR WHEN SEPARATION REQUIREMENTS CANNOT BE MET.
- ENTIRE SEWER LATERAL ASSEMBLY SHALL BE AIR TESTED CONCURRENTLY WITH SEWER MAIN.
- INDIVIDUAL LATERALS SHALL BE CLEANED AND FLUSHED PRIOR TO FLUSHING SANITARY SEWER MAINS.
- LATERAL SHALL NOT BE BACK-FILLED UNTIL INSPECTED BY THE FAYPWC PROJECT COORDINATOR.
- WYE CONNECTIONS SHALL NOT BE USED TO TIE LATERALS INTO A MANHOLE.
- IF BENDS ARE APPROVED BY THE PROJECT COORDINATOR, STONE BEDDING IS REQUIRED TO BE INSTALLED FROM UNDISTURBED (SEE DETAIL S.12) SOIL TO BOTTOM OF BEND.
- PVC COMBINATION SHALL BE A MOLDED WYE AND BEND, GASKETED, SDR-26, AS MANUFACTURED BY HARCO, GPK, PLASTIC TRENDS, OR APPROVED EQUAL.
- NO MORE THAN 4, FOUR-INCH LATERALS OR 3, SIX-INCH LATERALS SHALL ENTER A 4' DIAMETER TERMINAL MANHOLE. NO MORE THAN 2 LATERALS (REGARDLESS OF SIZE) SHALL ENTER ALL OTHER 4' DIAMETER MANHOLES. ALL LATERALS SHALL HAVE AN INDIVIDUAL TROUGH. 5' DIAMETER MANHOLES SHALL BE USED IF THE ABOVE CONDITIONS ARE NOT MET.
- ALL LATERALS (4" AND 6") SHALL UTILIZE A 4" RISER (STACK).
- REFER TO DETAIL S.12 FOR SEPARATION REQUIREMENTS.
- FOR SINGLE FAMILY RESIDENTIAL LOTS, CLEANOUT SHALL BE LOCATED 18" FROM RIGHT-OF-WAY OR EASEMENT. FOR ALL NON-SINGLE FAMILY LOTS, CLEANOUT SHALL BE NO CLOSER THAN 10' TO FRONT OF BUILDING, UNLESS OTHERWISE APPROVED BY FAYPWC.

THE FOLLOWING TABLE SUMMARIZES THE MATERIALS TO BE UTILIZED FOR SEWER MAIN TO LATERAL CONNECTIONS:

	PVC Main	DI Main
DI Lateral	DI fitting or approved saddle	MJ fitting or approved saddle
PVC Lateral	PVC fitting or approved saddle	MJ fitting with transition gasket or approved saddle

NOTE: REFER TO FAYPWC TECHNICAL SPECIFICATIONS FOR ADDITIONAL INFORMATION.

SEWER LATERAL NOTES (4-INCH AND 6-INCH)		FAYETTEVILLE PUBLIC WORKS COMMISSION FAYETTEVILLE, N.C.		NO.	DATE	REVISION
DWG. NO. S.11		WATER RESOURCES ENGINEERING DEPARTMENT				
SHEET NO. 1 OF 1	DATE: JAN. 01, 2022	DWG. BY: FAYPWC	APPROVED BY: M.M.M.	3	01/13	REVISED NOTES AND ADDED TABLE
				4	01/15	REVISED NOTE 22, TABLE
				5	07/18	REVISED NOTES 6, 9

S11-RESSLAT-NOTES.dwg

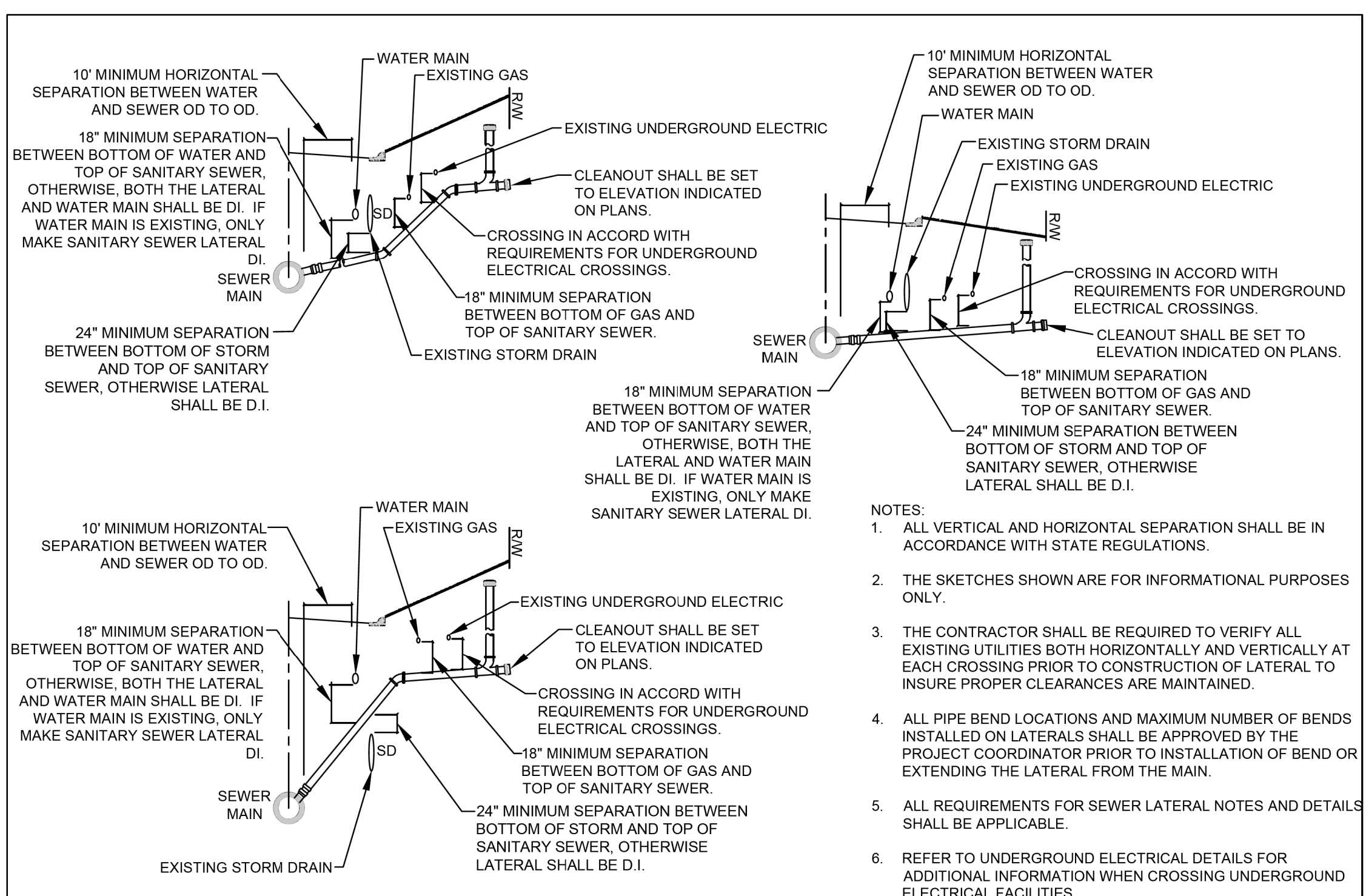

SEWER LATERAL UTILITY CONFLICT SEPARATION REQUIREMENTS N.T.S.		FAYETTEVILLE PUBLIC WORKS COMMISSION FAYETTEVILLE, N.C.		NO.	DATE	REVISION
DWG. NO. S.12		WATER RESOURCES ENGINEERING DEPARTMENT				
SHEET NO. 1 OF 1	DATE: JAN. 01, 2022	DWG. BY: FAYPWC	APPROVED BY: M.M.M.	1	01/05	REVISED NOTES 1 AND 6
				2	11/06	ADDED NOTE ON DI LATERALS
				3	03/10	ADDED LATERAL AND WM SEPARATION

S12-UTIL-CONFLICT.dwg

## NOTES:

- THE SELECT BEDDING MATERIAL SHALL BE WELL GRADED CRUSHED ROCK (NO. 5 OR NO. 57 STONE) FOR THE FULL WIDTH OF THE TRENCH.
- SELECT BEDDING MATERIAL SHALL EXTEND TO UNDISTURBED TRENCH WALLS.
- SELECT BEDDING MATERIAL SHALL BE PROPERLY PLACED TO THE SPRING LINE OF THE PIPE FOR ITS ENTIRE LENGTH.
- SUITABLE SOIL BEDDING IS DEFINED AS "NATIVE" SOIL EXCAVATED FROM THE TRENCH, FREE OF ROCKS, FOREIGN MATERIAL, AND FROZEN EARTH.
- SUITABLE BEDDING MATERIAL SHALL EXTEND TO UNDISTURBED TRENCH WALLS.
- IF GROUND CONDITIONS WARRANT, IT MAY BE NECESSARY TO BED DUCTILE IRON FORCE MAINS IN SELECT BEDDING MATERIAL (NO. 5 OR NO. 57 STONE) TO THE SPRINGLINE OF THE PIPE. SUCH INSTALLATION SHALL BE AS DIRECTED BY THE FAYPWC PROJECT COORDINATOR.

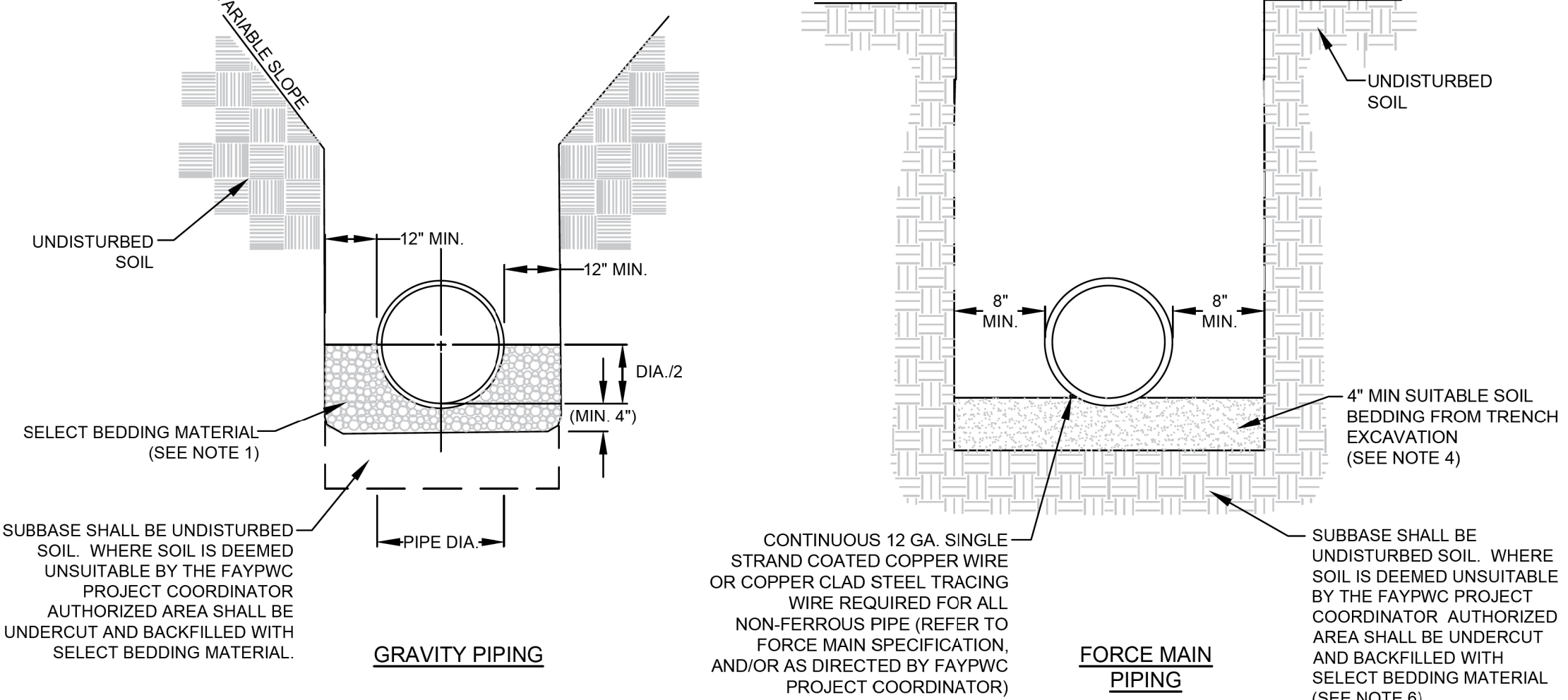

SEWER BEDDING N.T.S.		FAYETTEVILLE PUBLIC WORKS COMMISSION FAYETTEVILLE, N.C.		NO.	DATE	REVISION
DWG. NO. S.13		WATER RESOURCES ENGINEERING DEPARTMENT				
SHEET NO. 1 OF 1	DATE: JAN. 01, 2022	DWG. BY: FAYPWC	APPROVED BY: M.M.M.	1	01/01/05	REVISED NOTES
				2	01/01/16	REVISED NOTES

S13-SEWER-BEDDING.dwg

24-MAR-2022 10:37 AM C:\Users\matt\OneDrive\Engineering\UC\Projects\2020\_025\_U2519BA\_UT-DTL\_UC3K\_PSH.dgn

PROJECT REFERENCE NO.	SHEET NO.
<b>U-2519BA</b>	<b>UC-3L</b>
DESIGNED BY: DJ	
DRAWN BY: DJ	
CHECKED BY: TR	
APPROVED BY: TR	
REVISED:	
	3/24/2022
UTILITY CONSTRUCTION PLANS ONLY	

# UTILITY CONSTRUCTION

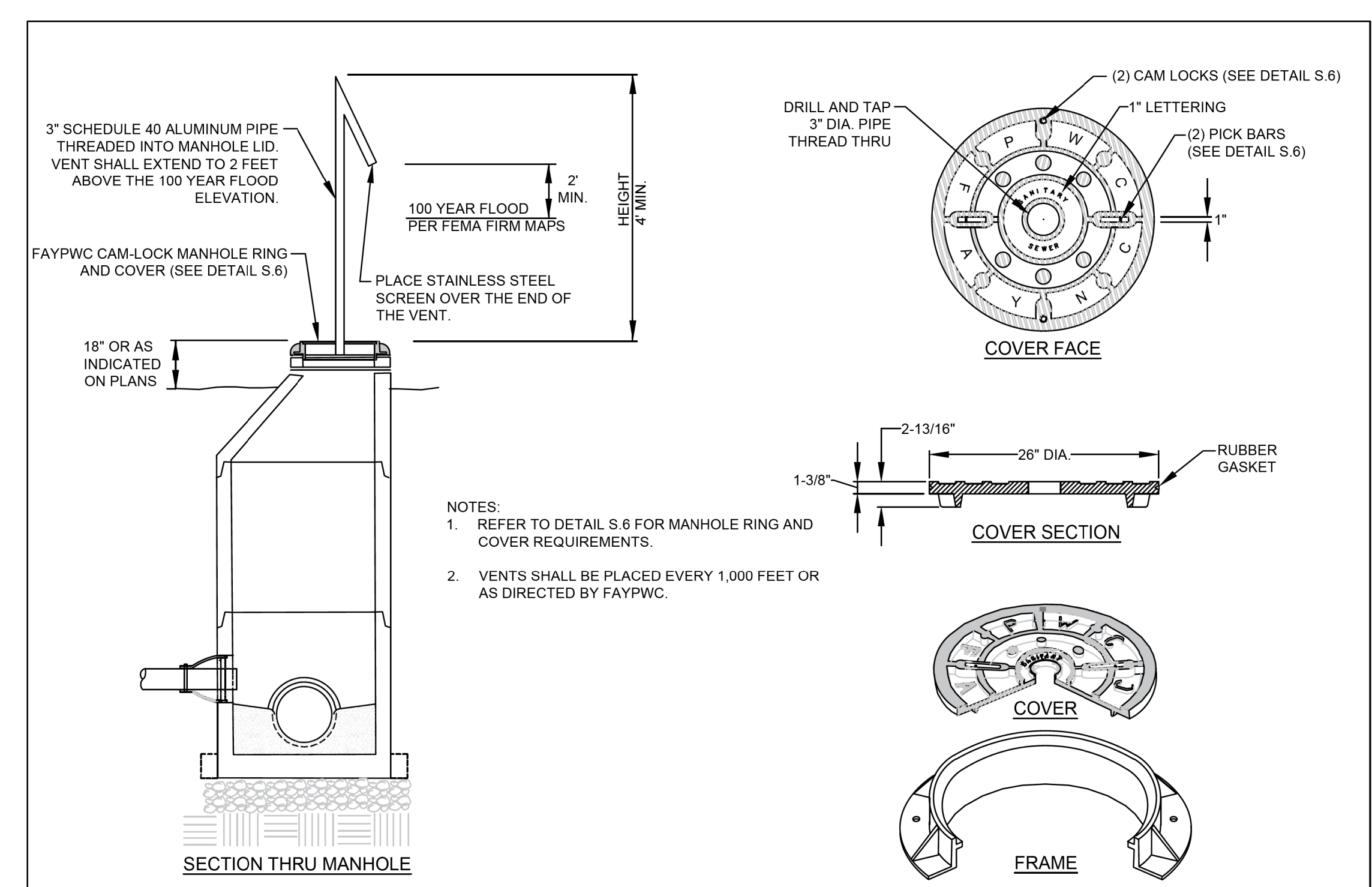

- NOTES:
- REFER TO DETAIL S.6 FOR MANHOLE RING AND COVER REQUIREMENTS.
  - VENTS SHALL BE PLACED EVERY 1,000 FEET OR AS DIRECTED BY FAYPWC.

MANHOLE VENT N.T.S.		FAYETTEVILLE PUBLIC WORKS COMMISSION FAYETTEVILLE, N.C.			NO.	DATE	REVISION
SHEET NO. 1 OF 1	DWG. NO. S.17 DATE: JAN. 01, 2022	DWG. BY: FAYPWC APPROVED BY: M.M.M.	WATER RESOURCES ENGINEERING DEPARTMENT				

S17-MH-VENT.dwg

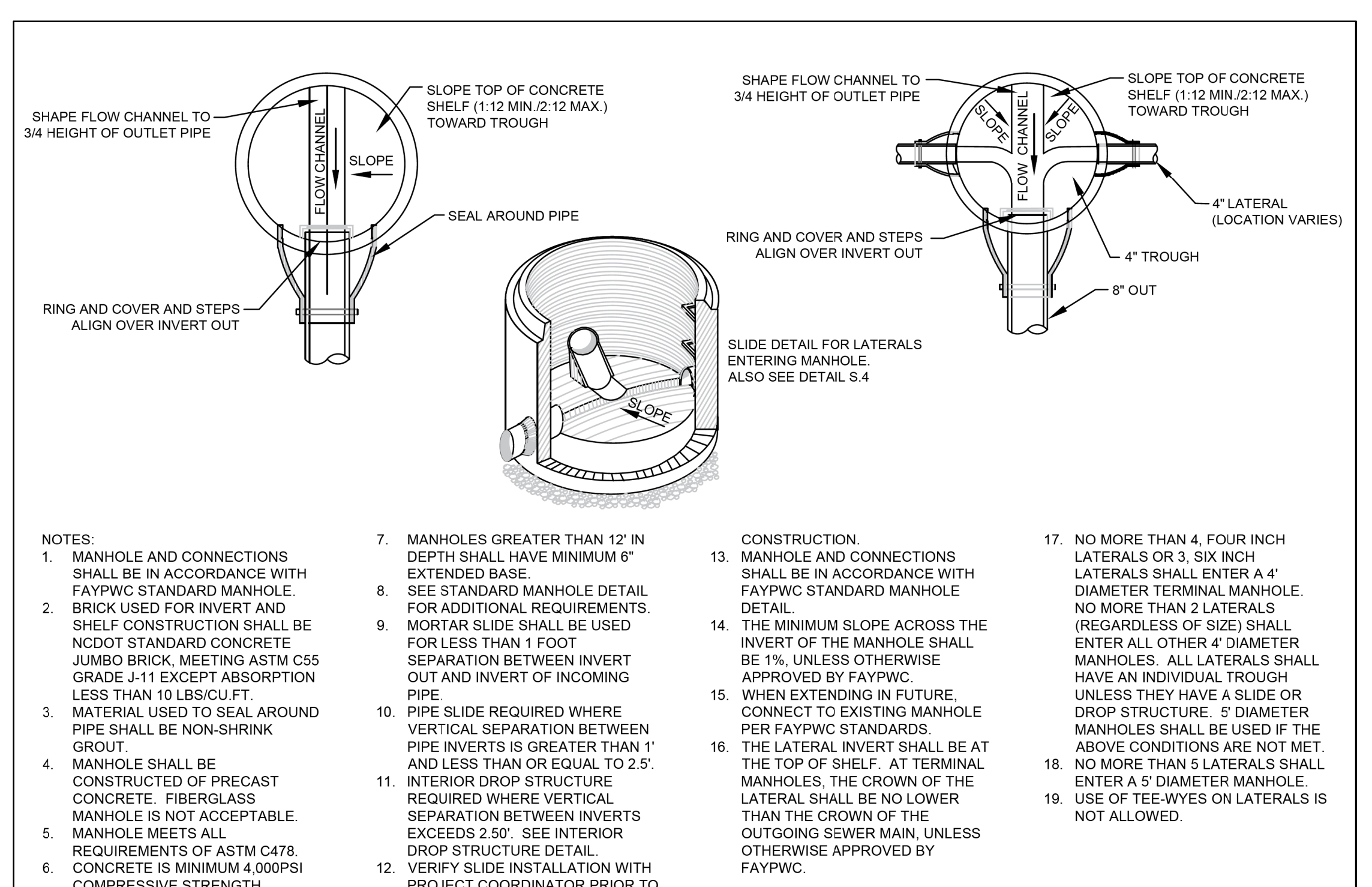

- NOTES:
- MANHOLE AND CONNECTIONS SHALL BE IN ACCORDANCE WITH FAYPWC STANDARD MANHOLE.
  - BRICK USED FOR INVERT AND SHELF CONSTRUCTION SHALL BE NCDOT STANDARD CONCRETE JUMBO BRICK, MEETING ASTM C55 GRADE J-11 EXCEPT ABSORPTION LESS THAN 10 LBS/CU.FT.
  - MATERIAL USED TO SEAL AROUND PIPE SHALL BE NON-SHRINK GROUT.
  - MANHOLE SHALL BE CONSTRUCTED OF PRECAST CONCRETE. FIBERGLASS MANHOLE IS NOT ACCEPTABLE. MANHOLE MEETS ALL REQUIREMENTS OF ASTM C478.
  - CONCRETE IS MINIMUM 4,000PSI COMPRESSIVE STRENGTH.
  - MANHOLES GREATER THAN 12" IN DEPTH SHALL HAVE MINIMUM 6" EXTENDED BASE.
  - SEE STANDARD MANHOLE DETAIL FOR ADDITIONAL REQUIREMENTS.
  - MORTAR SLIDE SHALL BE USED FOR LESS THAN 1 FOOT SEPARATION BETWEEN INVERT OUT AND INVERT OF INCOMING PIPE.
  - PIPE SLIDE REQUIRED WHERE VERTICAL SEPARATION BETWEEN PIPE INVERTS IS GREATER THAN 1' AND LESS THAN OR EQUAL TO 2.5'.
  - INTERIOR DROP STRUCTURE REQUIRED WHERE VERTICAL SEPARATION BETWEEN INVERTS EXCEEDS 2.50'. SEE INTERIOR DROP STRUCTURE DETAIL.
  - VERIFY SLIDE INSTALLATION WITH PROJECT COORDINATOR PRIOR TO CONSTRUCTION.
  - MANHOLE AND CONNECTIONS SHALL BE IN ACCORDANCE WITH FAYPWC STANDARD MANHOLE DETAIL.
  - THE MINIMUM SLOPE ACROSS THE INVERT OF THE MANHOLE SHALL BE 1%, UNLESS OTHERWISE APPROVED BY FAYPWC.
  - WHEN EXTENDING IN FUTURE, CONNECT TO EXISTING MANHOLE PER FAYPWC STANDARDS.
  - THE LATERAL INVERT SHALL BE AT THE TOP OF SHELF. AT TERMINAL MANHOLES, THE CROWN OF THE LATERAL SHALL BE NO LOWER THAN THE CROWN OF THE OUTGOING SEWER MAIN, UNLESS OTHERWISE APPROVED BY FAYPWC.
  - NO MORE THAN 4, FOUR INCH LATERALS OR 3, SIX INCH LATERALS SHALL ENTER A 4' DIAMETER TERMINAL MANHOLE. NO MORE THAN 2 LATERALS (REGARDLESS OF SIZE) SHALL ENTER ALL OTHER 4' DIAMETER MANHOLES. ALL LATERALS SHALL HAVE AN INDIVIDUAL TROUGH UNLESS THEY HAVE A SLIDE OR DROP STRUCTURE. 5' DIAMETER MANHOLES SHALL BE USED IF THE ABOVE CONDITIONS ARE NOT MET.
  - NO MORE THAN 5 LATERALS SHALL ENTER A 5' DIAMETER MANHOLE.
  - USE OF TEE-WYES ON LATERALS IS NOT ALLOWED.

TERMINAL MANHOLE N.T.S.		FAYETTEVILLE PUBLIC WORKS COMMISSION FAYETTEVILLE, N.C.			NO.	DATE	REVISION
SHEET NO. 1 OF 1	DWG. NO. S.20 DATE: JAN. 01, 2022	DWG. BY: FAYPWC APPROVED BY: M.M.M.	WATER RESOURCES ENGINEERING DEPARTMENT				

S20-TERMINAL-MANHOLE.dwg



PROJECT REFERENCE NO.	SHEET NO.
<b>U-2519BA</b>	<b>UC-3M</b>
DESIGNED BY: DJ	
DRAWN BY: DJ	
CHECKED BY: TR	
APPROVED BY: TR	
REVISED:	
	3/24/2022
	UTILITY CONSTRUCTION PLANS ONLY

**UTILITY CONSTRUCTION**

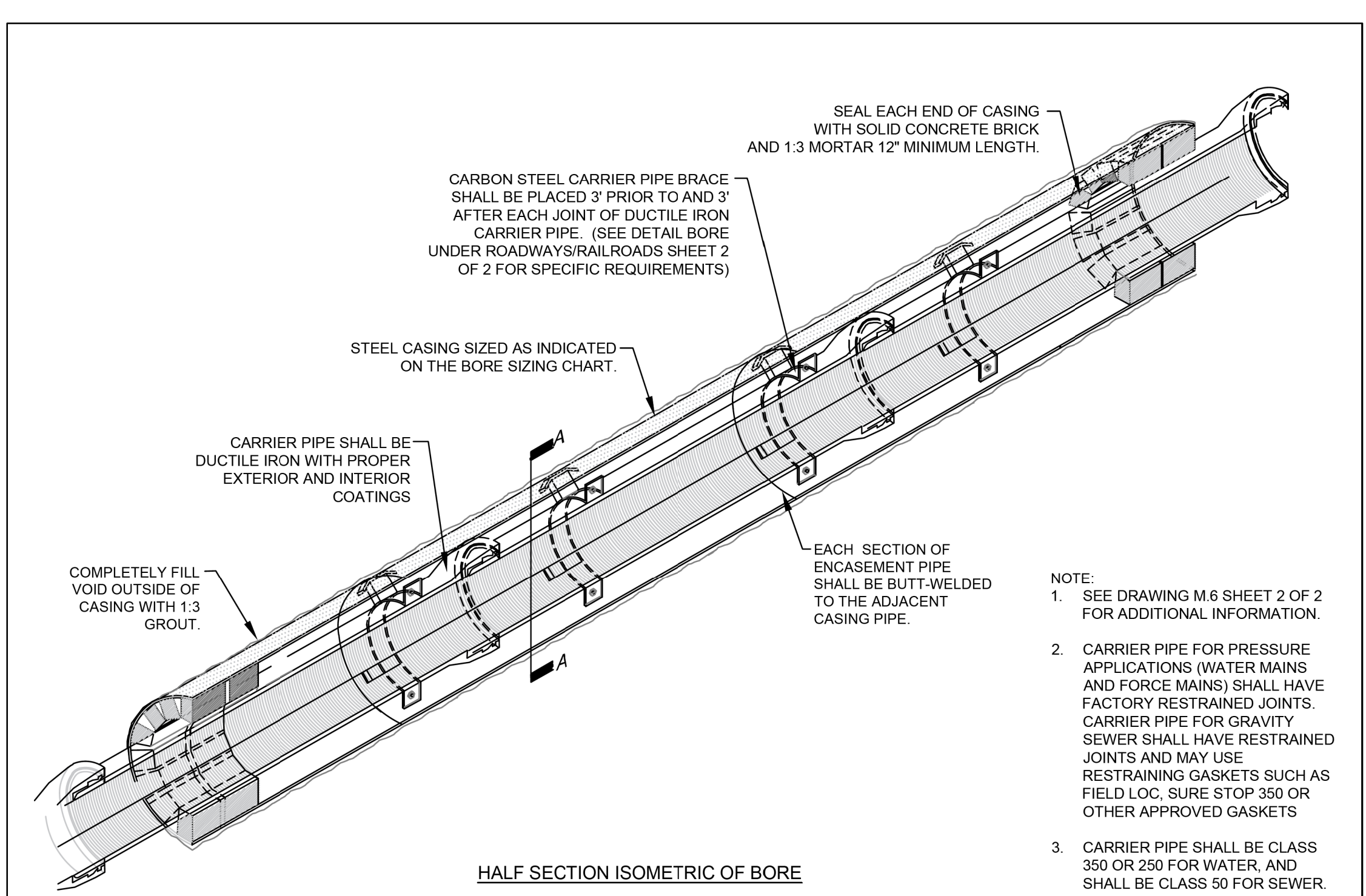

HALF SECTION ISOMETRIC OF BORE

BORE UNDER ROADWAYS/RAILROADS N.T.S.		FAYETTEVILLE PUBLIC WORKS COMMISSION FAYETTEVILLE, N.C.			NO.	DATE	REVISION
SHEET NO. 1 OF 2	DWG. NO. M.6 DATE: JAN. 01, 2022	DWG. BY: FAYPWC APPROVED BY: M.M.M.	WATER RESOURCES ENGINEERING DEPARTMENT		1	01/05	ADDED NOTES 2 AND 3
				2	10/09	CLARIFIED RESTRAINT REQUIREMENTS	

M6-BORE-ROAD-RAIL.dwg

CARRIER PIPE SIZE	MIN. CASING SIZE	ROADWAYS MIN. WALL THICKNESS	RAILROADS MIN. WALL THICKNESS
4"	10"	0.188"	0.188"
6"	12"	0.25"	0.281"
8"	16"	0.25"	0.281"
12"	24"	0.25"	0.375"
16"	30"	0.312"	0.469"
18"	30"	0.312"	0.469"
24"	36"	0.375"	0.532"
30"	42"	0.500"	0.625"
36"	48"	0.500"	0.688"

\*CONTRACTOR MAY SUBSTITUTE A LARGER SIZE CASING PIPE HAVING THE MINIMUM WALL THICKNESS SHOWN FOR SEWER MAINS. ALL ADDITIONAL COSTS SHALL BE INCLUDED IN THE NET PRICE BID FOR BORING AND JACKING.

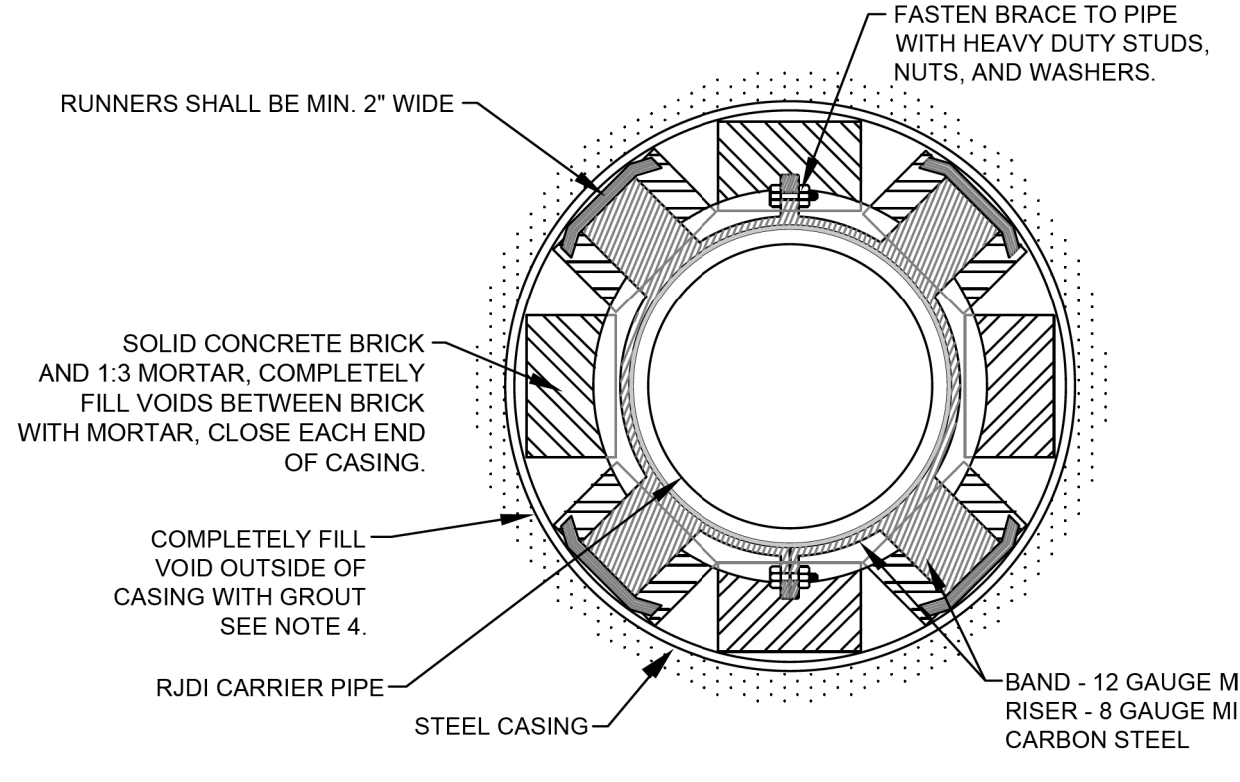

SECTION "A-A" CARBON STEEL CARRIER PIPE BRACE

BORE UNDER ROADWAYS/RAILROADS N.T.S.		FAYETTEVILLE PUBLIC WORKS COMMISSION FAYETTEVILLE, N.C.			NO.	DATE	REVISION
SHEET NO. 2 OF 2	DWG. NO. M.6 DATE: JAN. 01, 2022	DWG. BY: FAYPWC APPROVED BY: M.M.M.	WATER RESOURCES ENGINEERING DEPARTMENT		1	02/11/04	ADDED 8" CARRIER PIPE TO BORE SIZING CHART
				2	07/10	REVISED NOTES, SIZING CHART	

M6-BORE-ROAD-RAIL.dwg

- NOTES:
- INSTALLATION SHALL BE DRY BORE AND JACKING OF SMOOTH WALL STEEL PIPE. JETTING OR WET BORING WITH WATER SHALL NOT BE ALLOWED.
  - SEE BORE SIZING CHART FOR CARRIER PIPE SIZE AND STEEL CASING SIZE, MINIMUM DIAMETER, AND WALL THICKNESS.
  - CASING PIPE SHALL BE IN ACCORDANCE WITH ASTM A-53, GRADE B WITH A MINIMUM YIELD STRENGTH OF 35,000PSI.
  - EACH END OF ENCASEMENT TO BE PLUGGED WITH BRICK. ALL VOIDS OUTSIDE THE CASING PIPE SHALL BE COMPLETELY FILLED WITH 1:3 PORTLAND CEMENT GROUT AT SUFFICIENT PRESSURE TO INSURE NO SETTLEMENT OF ROADWAY/RAILROAD. METHOD OF GROUTING SHALL BE AS APPROVED BY THE PERMITTING AGENCY.
  - IT IS RECOMMENDED THAT THE BORE BE ACCOMPLISHED BEFORE PIPE CONSTRUCTION BEGINS.
  - THE BORING SHALL BE PERFORMED FROM "UPSTREAM" TO "DOWNSTREAM" DIRECTION MAINTAINING THE CRITICAL DOWNSTREAM INVERT ELEVATION. SHOULD THE BORE NOT BE ON GRADE, A REVISED PLAN SHALL BE SUBMITTED TO FAYPWC FOR APPROVAL.
  - THE BORING OPERATION SHALL BE CONDUCTED IN A MANNER THAT THE FLOW OF TRAFFIC IS NOT IMPEDED OR IN SUCH A MANNER SO AS NOT TO CREATE A HAZARD.
  - IF AN OBSTRUCTION IS ENCOUNTERED DURING THE BORING OPERATION, THE AUGER SHALL BE WITHDRAWN, THE EXCESS CASING PIPE CUT-OFF, CAPPED AND THE INTERIOR AND EXTERIOR VOIDS SHALL BE COMPLETELY FILLED WITH 1:3 PORTLAND CEMENT GROUT UNDER PRESSURE. NO SEPARATE PAYMENT FOR UNSUCCESSFUL BORES.
  - CONTRACTOR SHALL FIELD ADJUST AND INSTALL PROPER PIPE BRACES TO ACCOMPLISH GRADE AND INVERTS AS SHOWN ON THE DRAWINGS.
  - A MANUAL CONTROL STEERING HEAD OR OTHER GUIDANCE SYSTEM IS RECOMMENDED FOR BORES 30" DIAMETER AND/OR LARGER AND FOR BORES EXCEEDING 100' IN LENGTH OR AS SPECIFIED.
  - SUBCONTRACTORS SHALL ADHERE TO ALL PERMIT REQUIREMENTS AND SHALL PROVIDE APPROVED INSURANCE CERTIFICATES AS REQUIRED.
  - CONTRACTOR SHALL EXECUTE AND PERFORM ALL REQUIREMENTS AND CONDITIONS STIPULATED BY THE PERMITTING AGENCY.
  - SEE DRAWING M.6 SHEET 1 OF 2 FOR ADDITIONAL INFORMATION.
  - CARRIER PIPE FOR PRESSURE APPLICATIONS (WATER MAINS AND FORCE MAINS) SHALL HAVE FACTORY RESTRAINED JOINTS. CARRIER PIPE FOR GRAVITY SEWER SHALL HAVE RESTRAINED JOINTS AND MAY USE RESTRAINING GASKETS SUCH AS FIELD LOC, SURE STOP 350, GRIPRING, OR OTHER APPROVED GASKETS.

PROJECT REFERENCE NO.	SHEET NO.
U-2519BA	UC-4
DESIGNED BY: VR	
DRAWN BY: WJM	
CHECKED BY: AMH	
APPROVED BY: AA	
REVISED:	
NORTH CAROLINA DEPARTMENT OF TRANSPORTATION	
UTILITIES ENGINEERING SEC. PHONE: (919) 707-6690 FAX: (919) 250-4151	UTILITY CONSTRUCTION PLANS ONLY

**UTILITY NOTE:**

1. SEQUENCE INSTALLATION OF PROP. 36" STEEL ENCASUREMENT FOR FUTURE WATER MAIN SO IT DOES NOT CONFLICT WITH THE KING ROAD DETOUR. CONSTRUCT THE STEEL ENCASUREMENT PRIOR TO THE KING ROAD DETOUR OR AFTER THE DETOUR IS NO LONGER NEEDED. SEQUENCE CONSTRUCTION OF PROP. 36" STEEL ENCASUREMENT WITH DRAINAGE STRUCTURE 1314. PROP. 36" STEEL ENCASUREMENT SHALL BE MADE DORMANT FOR FUTURE USE OF A 12" RUDIP PRESSURE CLASS 350 WATER MAIN.
2. STEEL ENCASUREMENT UNDER PNG/DUKE ENERGY HIGH PRESSURE TRANSMISSION GAS MAIN SHALL BE PROVIDED WITH A FUSION BONDED EPOXY COATING ON ITS EXTERIOR.
3. B-# PWC REFERENCES SUPPLEMENTAL GEOTECHNICAL ENGINEERING DATA RETRIEVED TO ASSIST BIDDERS IN DEFINING EXISTING SOIL CONDITIONS.
4. CONTRACTOR SHALL COORDINATE WITH FAYPWC COORDINATOR TO SCHEDULE AS-BUILT SURVEY OF ENCASUREMENT ENDS PRIOR TO SEALING ENDS AND BACKFILLING ACCESS PITS. MINIMUM 3 BUSINESS DAY NOTICE SHALL BE REQUIRED.
5. CONTRACTOR SHALL ABIDE BY ALL TERMS AND CONDITIONS OF PNG/DUKE ENERGY'S APPROVAL OF THE ENCROACHMENT OF THE STEEL ENCASUREMENT IN THEIR EASEMENT. CONTRACTOR SHALL BE RESPONSIBLE FOR PROVIDING PNG/DUKE ENERGY RIGHT OF WAY AGENT AN OBSERVATION HOLE THAT ALLOWS THEIR EXISTING EXISTING GAS MAIN TO BE OBSERVED WHILE THE STEEL ENCASUREMENT IS JACKED UNDER THE GAS MAIN. THE OBSERVATION HOLE SHALL BE VACUUM EXCAVATED TO NO LOWER THAN THE BOTTOM OF THE GAS MAIN. THE HOLE SHALL BE BACKFILLED AND TAMPED IN ACCORDANCE WITH PNG RIGHT OF WAY AGENT INSTRUCTIONS.

-Y14-  
 PI Sta 20+46.87  
 $\Delta = 0'15"15.0" (LT)$   
 $D = 0'17"11.3"$   
 $L = 88.72'$   
 $T = 44.36'$   
 $R = 20,000.00'$   
 SE = NC

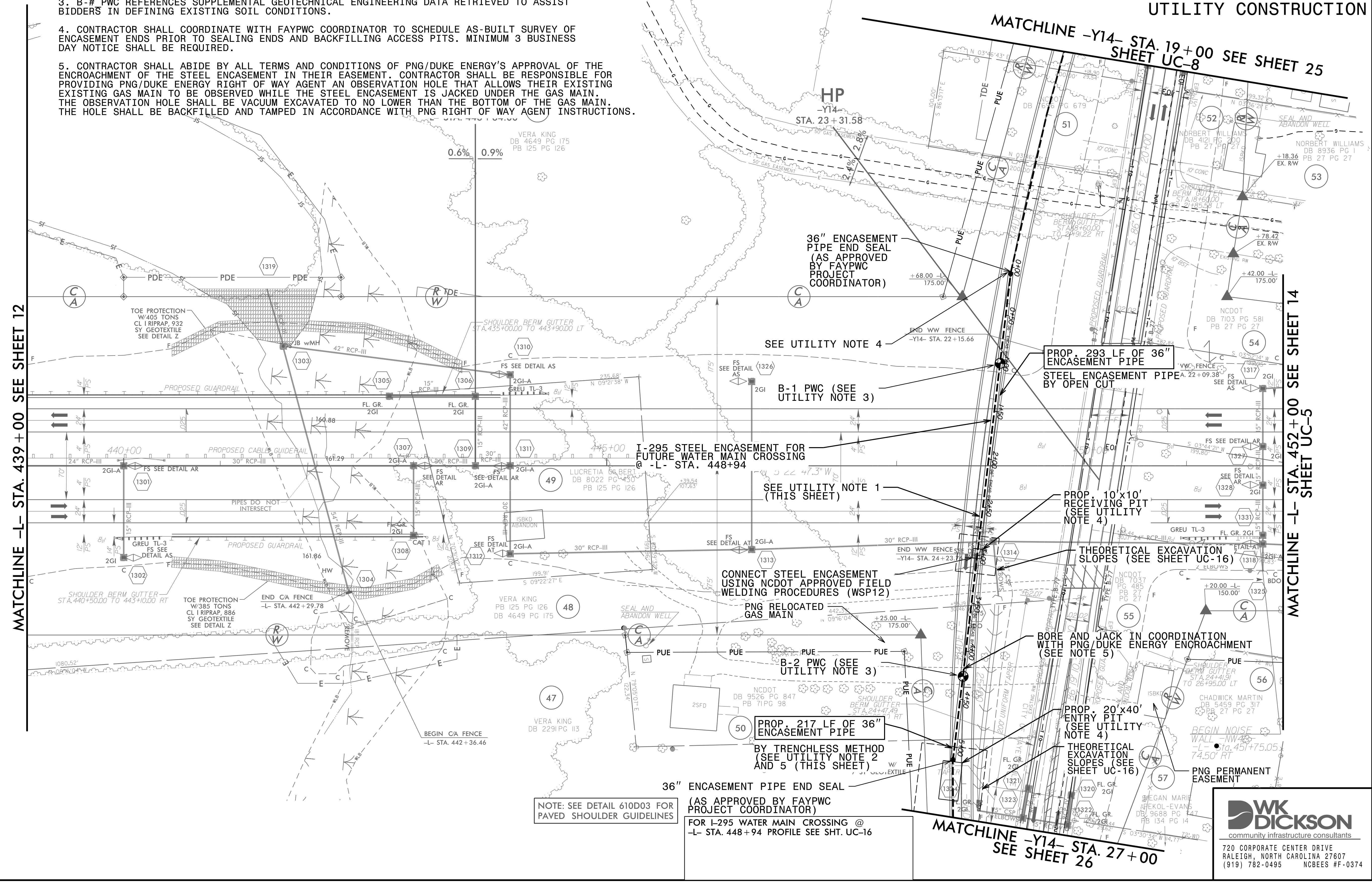

MATCHLINE -L- STA. 439 + 00 SEE SHEET 12

MATCHLINE -L- STA. 452 + 00 SEE SHEET 14  
 SHEET UC-5

MATCHLINE -Y14- STA. 19+00 SEE SHEET 25  
 SHEET UC-8

MATCHLINE -Y14- STA. 27+00  
 SEE SHEET 26

NOTE: SEE DETAIL 610D03 FOR PAVED SHOULDER GUIDELINES

FOR I-295 WATER MAIN CROSSING @  
 -L- STA. 448 + 94 PROFILE SEE SHT. UC-16

**WK DICKSON**  
 community infrastructure consultants  
 720 CORPORATE CENTER DRIVE  
 RALEIGH, NORTH CAROLINA 27607  
 (919) 782-0495 NCBEES #F-0374

8/17/99  
 07-APR-2022 07:14  
 Z:\Projects\Environmental\Fayetteville Public Works Commission\2018020800RA - Area 32\CADD\Microstation\U2519-BA\Utilities\U2519BA\_UC\_psh13.dgn  
 wheel

UTILITY NOTE:

1. STEEL ENCASUREMENT UNDER PNG/DUKE ENERGY HIGH PRESSURE TRANSMISSION GAS MAIN SHALL BE PROVIDED WITH A FUSION BONDED EPOXY COATING ON ITS EXTERIOR.
2. B-# PWC REFERENCES SUPPLEMENTAL GEOTECHNICAL ENGINEERING DATA RETRIEVED TO ASSIST BIDDERS IN DEFINING EXISTING SOIL CONDITIONS.
3. CONTRACTOR SHALL COORDINATE WITH FAYPWC COORDINATOR TO SCHEDULE AS-BUILT SURVEY OF ENCASUREMENT ENDS PRIOR TO THREADING CARRIER PIPE, SEALING ENDS AND BACKFILLING ACCESS PITS. MINIMUM 3 BUSINESS DAYS NOTICE SHALL BE REQUIRED.
4. CONTRACTOR SHALL ABIDE BY ALL TERMS AND CONDITIONS OF PNG/DUKE ENERGY'S APPROVAL OF THE ENCROACHMENT OF THE STEEL ENCASUREMENT IN THEIR EASEMENT. CONTRACTOR SHALL BE RESPONSIBLE FOR PROVIDING PNG/DUKE ENERGY RIGHT OF WAY AGENT AN OBSERVATION HOLE THAT ALLOWS THEIR EXISTING GAS MAIN TO BE OBSERVED WHILE THE STEEL ENCASUREMENT IS JACKED UNDER THE GAS MAIN. THE OBSERVATION HOLE SHALL BE VACUUM EXCAVATED TO NO LOWER THAN THE BOTTOM OF THE MAIN. THE HOLE SHALL BE BACKFILLED AND TAMPED IN ACCORDANCE WITH PNG RIGHT OF WAY AGENT INSTRUCTIONS.

PROJECT REFERENCE NO.	SHEET NO.
U-2519BA	UC-5
DESIGNED BY: VR	
DRAWN BY: WJM	
CHECKED BY: AMH	
APPROVED BY: AA	
REVISED:	
NORTH CAROLINA DEPARTMENT OF TRANSPORTATION	
UTILITIES ENGINEERING SEC. PHONE: (919) 707-6690 FAX: (919) 250-4151	
UTILITY CONSTRUCTION PLANS ONLY	

UTILITY CONSTRUCTION

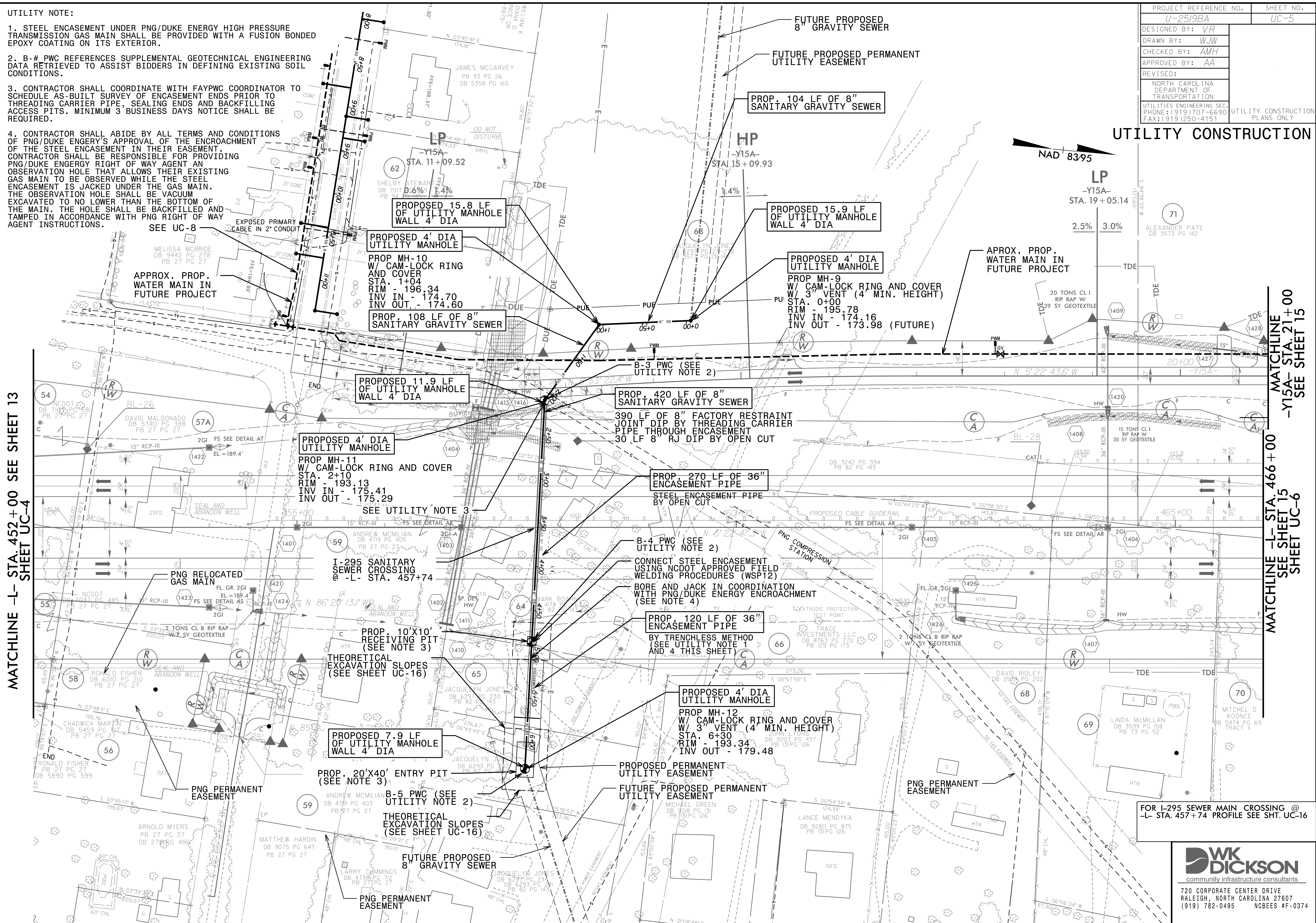

FOR I-295 SEWER MAIN CROSSING @ -L- STA. 457+74 PROFILE SEE SHT. UC-16

**WK DICKSON**  
community infrastructure consultants

720 CORPORATE CENTER DRIVE  
RALEIGH, NORTH CAROLINA 27607  
(919) 782-0495 NCBES #F-0374

8/17/99  
 22-MAR-2022 12:41  
 C:\Projects\Environmental\Fayetteville Public Works Commission\2018\0208000RA - Area\_32\CADD\Microstation\U2519-BA\Utilities\U2519BA\_UC\_psh14.dgn  
 MATCHLINE -L- STA. 452+00 SEE SHEET 13 SHEET UC-4  
 MATCHLINE -L- STA. 466+00 SEE SHEET 15 SHEET UC-6  
 MATCHLINE -Y15A- STA. 21+00 SEE SHEET 15

PROJECT REFERENCE NO.	SHEET NO.
U-2519BA	UC-6
DESIGNED BY: VR	
DRAWN BY: WJW	
CHECKED BY: AMH	
APPROVED BY: AA	
REVISED:	
NORTH CAROLINA DEPARTMENT OF TRANSPORTATION	
UTILITIES ENGINEERING SEC. PHONE: (919) 707-6690 FAX: (919) 250-4151	UTILITY CONSTRUCTION PLANS ONLY

**UTILITY CONSTRUCTION**

**UTILITY NOTE:**

1. B-# PWC REFERENCES SUPPLEMENTAL GEOTECHNICAL ENGINEERING DATA RETRIEVED TO ASSIST BIDDERS IN DEFINING EXISTING SOIL CONDITIONS.
2. CONTRACTOR SHALL COORDINATE WITH FAYPWC COORDINATOR TO SCHEDULE AS-BUILT SURVEY OF ENCASEMENT ENDS PRIOR TO THREADING CARRIER PIPE, SEALING ENDS AND BACKFILLING ACCESS PITS. MINIMUM OF 3 BUSINESS DAYS NOTICE SHALL BE REQUIRED.

MATCHLINE -L- STA. 466+00 SEE SHEET 14 SHEET UC-5

MATCHLINE -L- STA. 479+00 SEE SHEET 16 SHEET UC-7

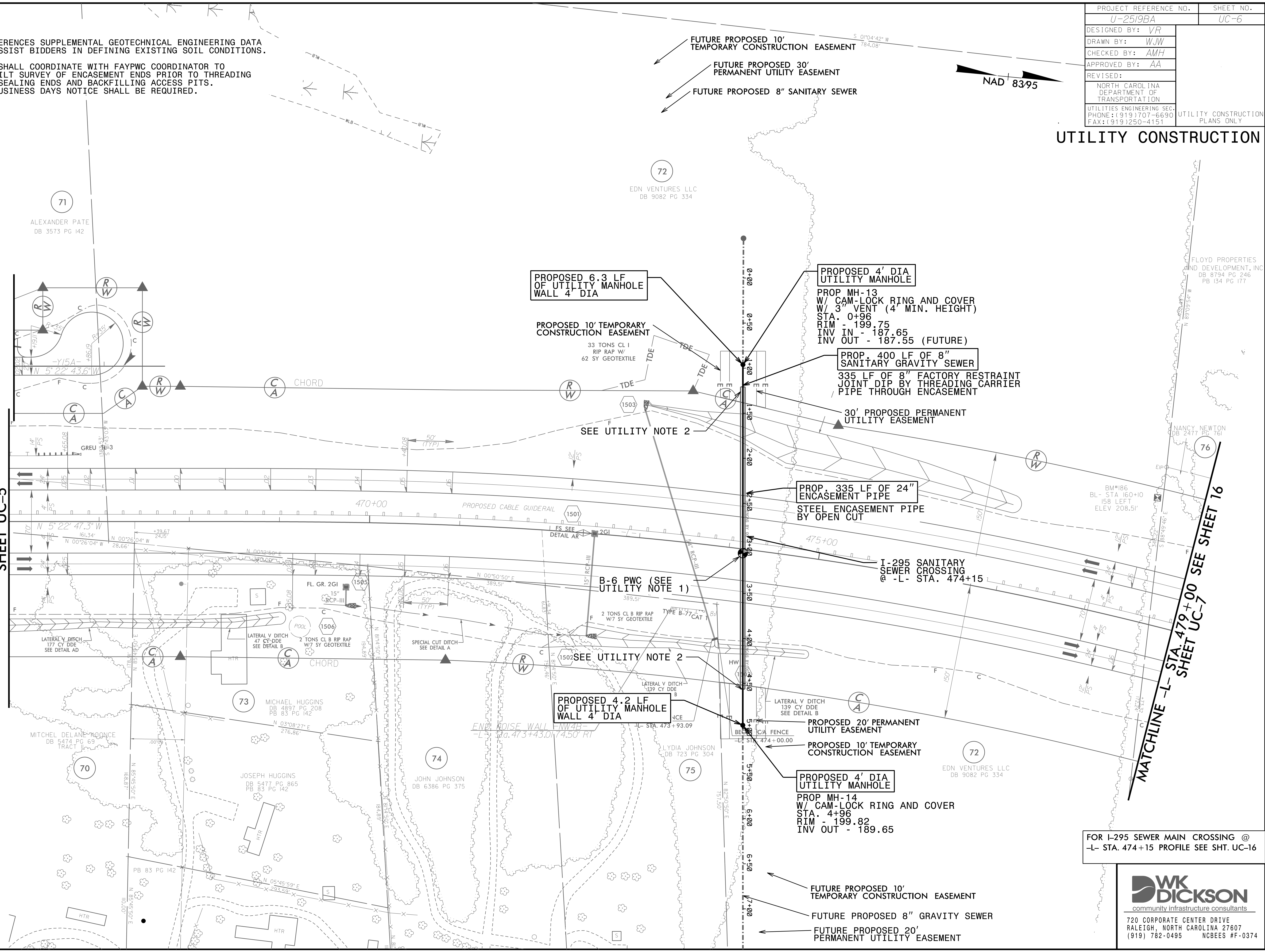

FOR I-295 SEWER MAIN CROSSING @ -L- STA. 474+15 PROFILE SEE SHT. UC-16

**WK DICKSON**  
community infrastructure consultants  
720 CORPORATE CENTER DRIVE  
RALEIGH, NORTH CAROLINA 27607  
(919) 782-0495 NCBEES #F-0374

22-MAR-2022 12:41 25-Projects-Environmental\Fayetteville Public Works Commission\20180000000RA - Area\_32\CADD\Microstation\U2519-BA\Utilities\U2519BA\_UC\_psh15.dgn

8/17/99  
22-MAR-2022 12:41  
Z:\Projects\Environmental\Fayetteville Public Works Commission\20160208000RA - Area\_32\CADD\Microstation\U2519-BA\Utilities\U2519BA\_UC\_psh16.dgn  
whb\lele - A - W02133

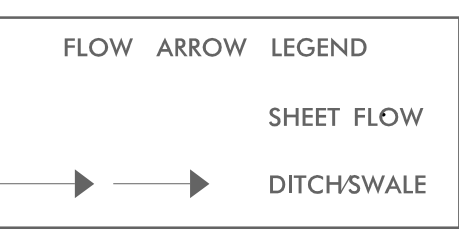

**UTILITY NOTE:**

1. B-# PWC REFERENCES SUPPLEMENTAL GEOTECHNICAL ENGINEERING DATA RETRIEVED TO ASSIST BIDDERS IN DEFINING EXISTING SOIL CONDITIONS.

2. CONTRACTOR SHALL COORDINATE WITH FAYPWC COORDINATOR TO SCHEDULE AS-BUILT SURVEY OF ENCASUREMENT ENDS PRIOR TO THREADING CARRIER PIPE, SEALING ENDS AND BACKFILLING ACCESS PITS. MINIMUM OF 3 BUSINESS DAYS NOTICE SHALL BE REQUIRED.

FLOYD PROPERTIES  
AND DEVELOPMENT, INC  
DB 8794 PG 246  
PB 134 PG 177

PROJECT REFERENCE NO.	SHEET NO.
U-2519BA	UC-7
DESIGNED BY: VR	
DRAWN BY: WJW	
CHECKED BY: AMH	
APPROVED BY: AA	
REVISED:	
NORTH CAROLINA DEPARTMENT OF TRANSPORTATION	
UTILITIES ENGINEERING SEC. PHONE: (919) 707-6690 FAX: (919) 250-4151	UTILITY CONSTRUCTION PLANS ONLY

MATCHLINE -L- STA. 479+00 SEE SHEET 15  
SHEET UC-6

MATCHLINE -L- STA. 491+00 SEE SHEET 17

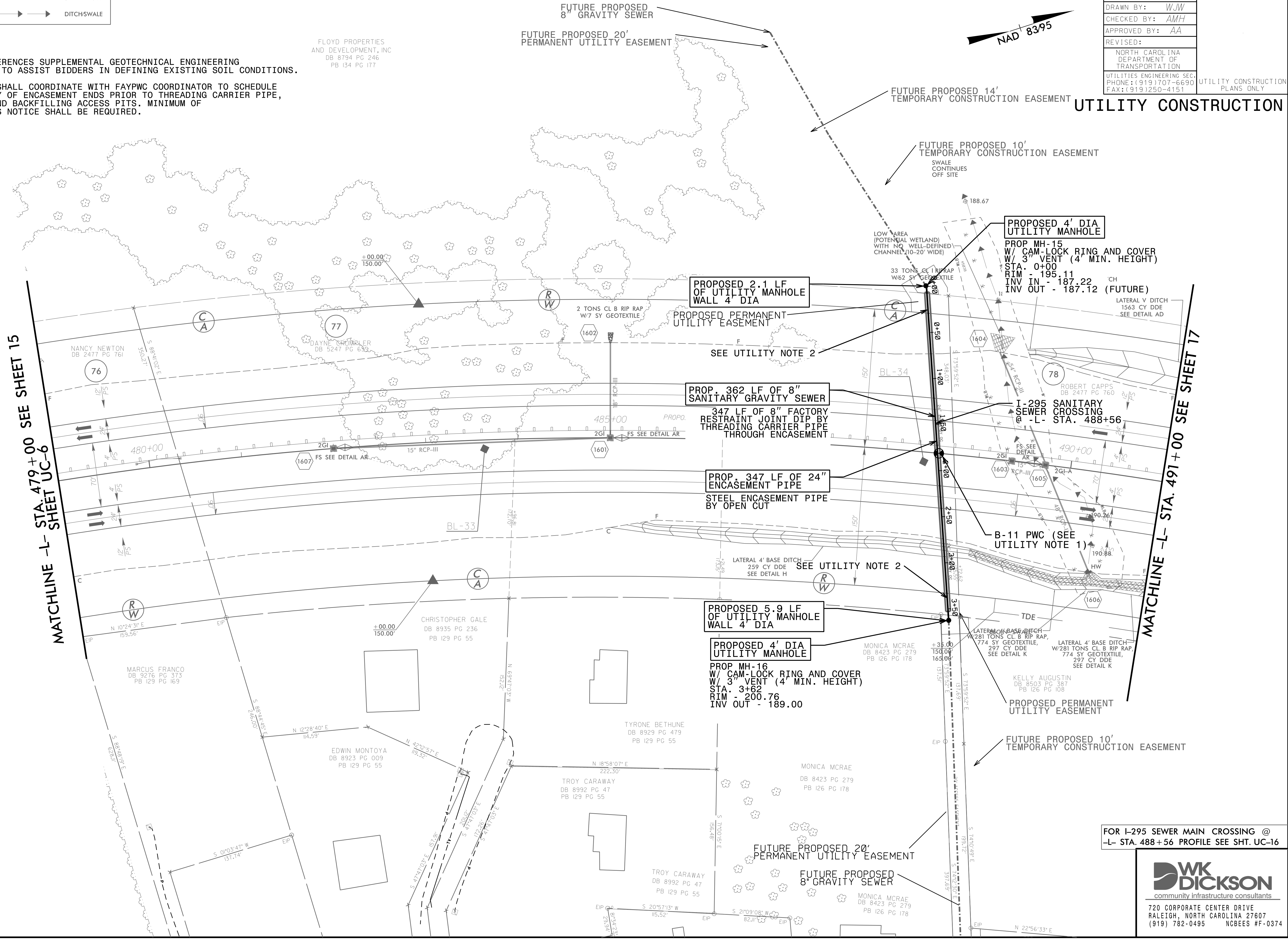

**FOR I-295 SEWER MAIN CROSSING @ -L- STA. 488+56 PROFILE SEE SHT. UC-16**



PROJECT REFERENCE NO.	U-2519BA
SHEET NO.	UC-8
DESIGNED BY:	VR
DRAWN BY:	WJM
CHECKED BY:	AMH
APPROVED BY:	AA
REVISED:	
NORTH CAROLINA DEPARTMENT OF TRANSPORTATION	
UTILITIES ENGINEERING SEC. PHONE: (919) 707-6690 FAX: (919) 250-4151	
UTILITY CONSTRUCTION PLANS ONLY	

**UTILITY CONSTRUCTION**

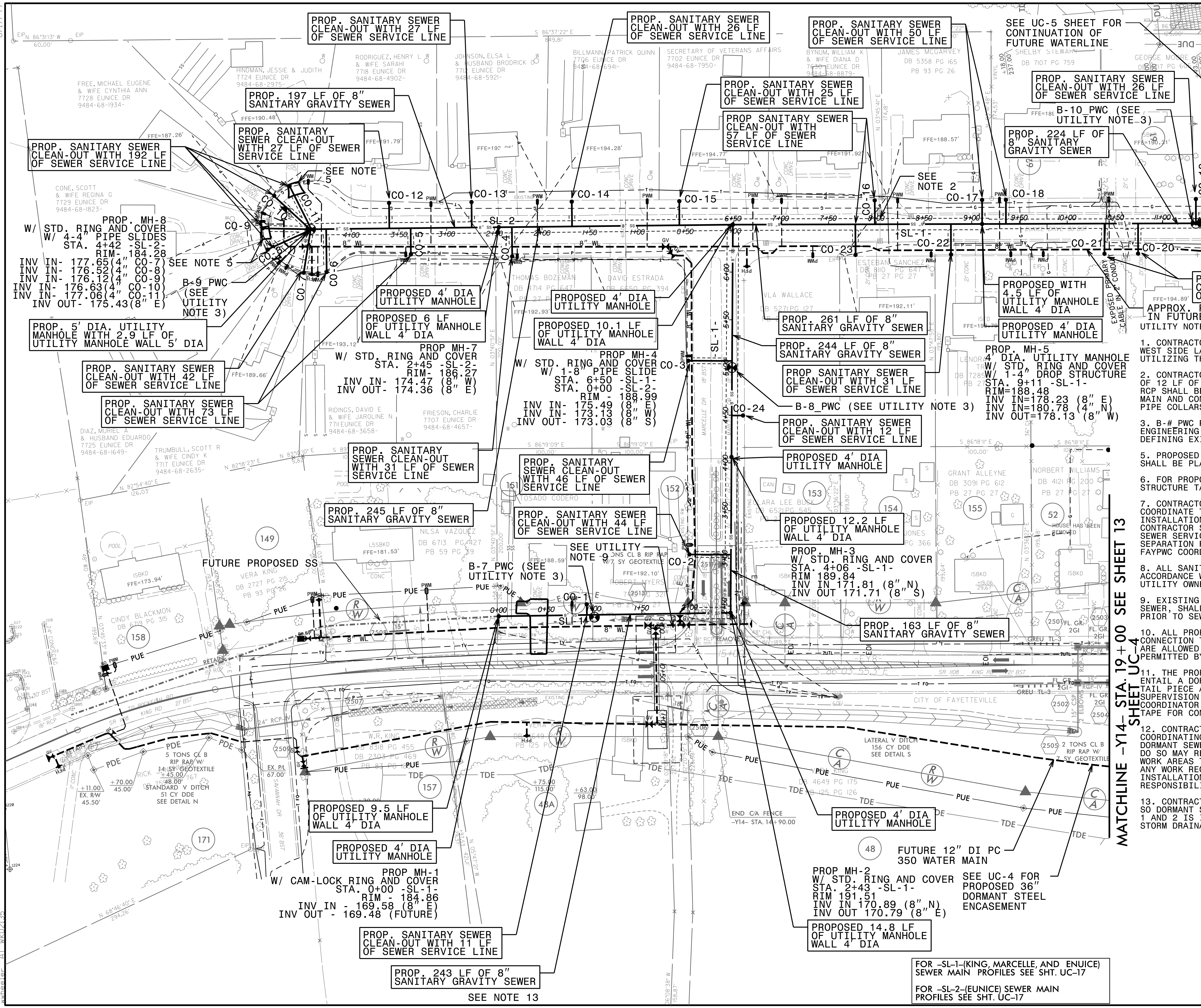

PROPOSED 4' DIA. UTILITY MANHOLE WITH 3.8 LF OF UTILITY MANHOLE WALL 4' DIA

PROP. MH-6 W/ STD. RING AND COVER W/ 1-4" PIPE SLIDE STA. 11+35 -SL-1- RIM - 190.47 INV IN - 183.02 (4" N) INV OUT - 180.64 (8" E)

PROP. SANITARY SEWER CLEAN-OUT WITH 64 LF OF SEWER SERVICE LINE

APPROX. PROP WATER MAIN IN FUTURE PROJECT

UTILITY NOTE:

- CONTRACTOR SHALL MAINTAIN ENTRANCE/EXIT ON WEST SIDE LANE FOR MARCELLE DR. TRAFFIC CONTROL UTILIZING THIS APPROACH SHALL ADHERE TO MUTCD.
- CONTRACTOR SHALL REMOVE AND REPLACE A MIN. OF 12 LF OF 24" RCP DRAINAGE PIPE. THE PROPOSED RCP SHALL BE CENTERED OVER THE PROPOSED SEWER MAIN AND CONNECTED TO EXISTING RCP WITH CONCRETE PIPE COLLARS. (APPROX. LOCATION -SL-1- STA. 8+04)
- B-# PWC REFERENCES SUPPLEMENTAL GEOTECHNICAL ENGINEERING DATA RETRIEVED TO ASSIST BIDDERS IN DEFINING EXISTING SOIL CONDITIONS.
- PROPOSED CLEANOUTS LOCATED WITHIN DRIVEWAYS SHALL BE PLACED AT GRADE WITH TRAFFIC RATED CAP.
- FOR PROPOSED CLEANOUT INFORMATION SEE CLEANOUT STRUCTURE TABLE ON SHEET UC-17.
- CONTRACTOR SHALL BE RESPONSIBLE TO COORDINATE THE PROPOSED SEWER LATERAL INSTALLATION WITH THE EXISTING UTILITIES. CONTRACTOR SHALL USE UTILITY OWNER STANDARD SEWER SERVICE LATERAL DETAIL. UTILITY CONFLICT SEPARATION REQUIREMENTS ONLY WHEN APPROVED BY FAYPWC COORDINATOR.
- ALL SANITARY SEWER CONSTRUCTION SHALL BE IN ACCORDANCE WITH UTILITY SPECIAL PROVISIONS AND UTILITY OWNER STANDARD DETAILS.
- EXISTING WELL ON PARCEL 152, NEAR PROPOSED SEWER, SHALL BE RELOCATED AND/OR ABANDONED PRIOR TO SEWER INSTALLATION BY OTHERS.
- ALL PROPOSED SEWER SHALL BE DORMANT. NO CONNECTION TO PROPOSED SEWER AND LATERAL STUBS ARE ALLOWED UNLESS OTHERWISE AUTHORIZED AND PERMITTED BY UTILITY OWNER.
- THE PROPOSED LATERAL INSTALLATION WILL ENTAIL A DORMANT SEWER TAPE WRAPPED AROUND THE TAIL PIECE AND UP THE CLEAN OUT STACK UNDER SUPERVISION FROM FAYPWC COORDINATOR. FAYPWC COORDINATOR WILL PROVIDE DORMANT SEWER WARNING TAPE FOR CONTRACTOR'S INSTALLATION.
- CONTRACTOR SHALL BE RESPONSIBLE FOR COORDINATING WITH FAYPWC COORDINATOR TO OBSERVE DORMANT SEWER TAPE INSTALLATION. FAILURE TO DO SO MAY RESULT IN CONTRACTOR UNCOVERING THE WORK AREAS TO EXPOSE THE INSTALLED TAPE. ANY WORK REQUIRED TO UNCOVER UNSUPERVISED INSTALLATIONS WILL BE THE CONTRACTOR'S RESPONSIBILITIES.
- CONTRACTOR SHALL SEQUENCE INSTALLATIONS SO DORMANT SEWER BETWEEN PROPOSED SSMH 1 AND 2 IS INSTALLED PRIOR TO THE PROPOSED STORM DRAINAGE.

MATCHLINE -Y14- STA. 19+00 SEE SHEET UC-4

FOR -SL-1-(KING, MARCELLE, AND ENUCE) SEWER MAIN PROFILES SEE SHT. UC-17

FOR -SL-2-(EUNICE) SEWER MAIN PROFILES SEE SHT. UC-17



720 CORPORATE CENTER DRIVE  
RALEIGH, NORTH CAROLINA 27607  
(919) 782-0495 NCBES #F-0374

25-MAR-2022, 12:41 PM Projects, Environmental\Fayetteville Public Works Commission\2018\02\08\000RA - Area\_32\CADD\Microstation\U2519BA\Utilities\U2519BA\_UC\_psh25.dgn

SEE UC-5 SHEET FOR CONTINUATION OF FUTURE WATERLINE

B-10 PWC (SEE UTILITY NOTE 3)

APPROX. PROP WATER MAIN IN FUTURE PROJECT

- UTILITY NOTE:**
1. SEQUENCE INSTALLATION OF PROP. 24" STEEL ENCASEMENT FOR FUTURE WATER MAIN SO IT DOES NOT CONFLICT WITH THE KING ROAD DETOUR. CONSTRUCT THE STEEL ENCASEMENT PRIOR TO THE KING ROAD DETOUR OR AFTER THE DETOUR IS NO LONGER NEEDED. PROP. 24" ENCASEMENT SHALL BE MADE DORMANT FOR FUTURE USE OF 8" RJDIP PRESSURE CLASS 350 WATER MAIN.
  2. ALL ENCASEMENT CONSTRUCTION SHALL BE IN ACCORDANCE WITH UTILITY SPECIAL PROVISIONS AND UTILITY OWNER STANDARD DETAILS.
  3. B-# PWC REFERENCES SUPPLEMENTAL GEOTECHNICAL ENGINEERING DATA RETRIEVED TO ASSIST BIDDERS IN DEFINING EXISTING SOIL CONDITIONS.
  4. CONTRACTOR SHALL COORDINATE WITH FAYPWC COORDINATOR TO SCHEDULE AS-BUILT SURVEY OF ENCASEMENT ENDS PRIOR TO SEALING ENDS AND BACKFILLING ACCESS PITS. MINIMUM 3 BUSINESS DAYS NOTICE SHALL BE REQUIRED.

8/17/99  
 22-MAR-2022 12:42  
 C:\Projects\Environmental\Fayetteville Public Works Commission\20180208000RA - Area\_32\CADD\Microstation\U2519-BA\Utilities\U2519BA\_UC\_psh25B.dgn  
 wheel@carroll.com

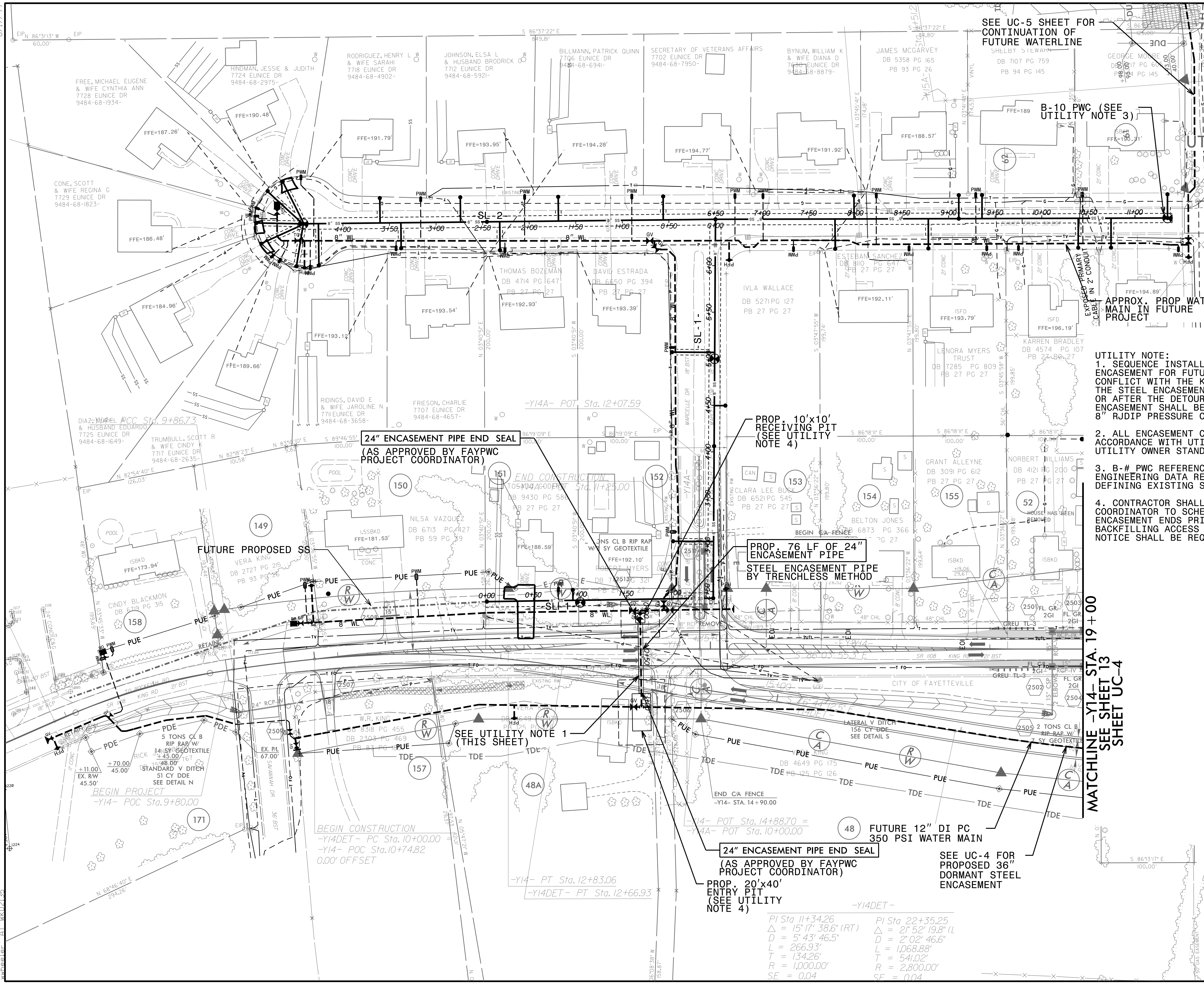

**24" ENCASEMENT PIPE END SEAL**  
 (AS APPROVED BY FAYPWC PROJECT COORDINATOR)

**PROP. 10'x10' RECEIVING PIT**  
 (SEE UTILITY NOTE 4)

**PROP. 76 LF OF 24" ENCASEMENT PIPE**  
**STEEL ENCASEMENT PIPE BY TRENCHLESS METHOD**

**SEE UTILITY NOTE 1 (THIS SHEET)**

**24" ENCASEMENT PIPE END SEAL**  
 (AS APPROVED BY FAYPWC PROJECT COORDINATOR)

**PROP. 20'x40' ENTRY PIT**  
 (SEE UTILITY NOTE 4)

**SEE UC-4 FOR PROPOSED 36" DORMANT STEEL ENCASEMENT**

**MATCHLINE -Y14- STA. 19+00 SEE SHEET 13 SHEET UC-4**

PI Sta 11+34.26	PI Sta 22+35.25
Δ = 15' 17" 38.6" (RT)	Δ = 21' 52" 19.8" (L)
D = 5' 43' 46.5"	D = 2' 02' 46.6"
L = 266.93'	L = 1,068.88'
T = 134.26'	T = 541.02'
R = 1,000.00'	R = 2,800.00'
SE = 0.04	SE = 0.04

FOR KING RD WATER MAIN CROSSING @ -Y14- STA. 14+25 PROFILE SEE SHT. UC-17B



720 CORPORATE CENTER DRIVE  
 RALEIGH, NORTH CAROLINA 27607  
 (919) 782-0495 NCBEES #F-0374