

**This electronic collection of documents is provided
for the convenience of the user
and is Not a Certified Document –**

**The documents contained herein were originally issued
and sealed by the individuals whose names and license
numbers appear on each page, on the dates appearing
with their signature on that page.**

**This file or an individual page
shall not be considered a certified document.**

**STATE OF NORTH CAROLINA
DEPARTMENT OF TRANSPORTATION**

**SIGNING PLAN
COLUMBUS COUNTY**

LOCATION: INTERCHANGE OF US 74 AND SR 1735 IN LAKE WACCAMAW

T.I.P.: R-5819 R-5820

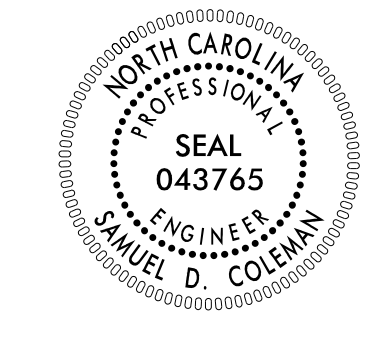
PROJECT REFERENCE NO. R-5819 R-5820	SHEET NO. SIGN-1
APPROVED: _____	
DATE: _____	
SEAL	
	
DOCUMENT NOT CONSIDERED FINAL UNLESS ALL SIGNATURES COMPLETED	

PLANS PREPARED FOR THE NCDOT BY:
M MOTT MACDONALD 1 & E, LLC
 1101 HAYNES STREET, SUITE 101
 RALEIGH, NC 27604
M NC LICENSE NO. F-0669

ROADWAY STANDARD DRAWING

THE FOLLOWING ROADWAY STANDARDS AS APPEAR IN "ROADWAY STANDARD DRAWINGS" - PROJECT SERVICES UNIT - N.C. DEPARTMENT OF TRANSPORTATION - RALEIGH, N.C., DATED JANUARY 2018 ARE APPLICABLE TO THIS PROJECT AND BY REFERENCE HEREBY ARE CONSIDERED A PART OF THESE PLANS:

STD. NO.	TITLE
901.10	TYPE 'A' SIGNS
901.20	TYPE 'B' SIGNS
901.50	ARROWS AND SHIELDS
901.70	SIGN STRINGERS AND SUPPORT SPACING
901.80	SIGN MOUNTING DETAILS - FOR TYPE A AND TYPE B SIGNS
903.10	GROUND MOUNTED SIGN SUPPORTS
904.10	ORIENTATION OF GROUND MOUNTED SIGNS
904.20	SECONDARY SIGN MOUNTING
904.30	SUPPLEMENTAL SIGN MOUNTING
904.40	MILEPOST AND PLACEMENT
904.50	MOUNTING OF TYPE 'D', 'E' AND 'F' SIGNS ON 'U' CHANNEL POSTS
910.20	SCHOOL MARKED AND UNMARKED CROSSWALKS / SPEED REDUCTION REQUIREMENTS
910.40	SINGLE/TWO LANE ROUNDABOUT WITH PEDESTRIAN
910.50	SIGNING FOR SPEED REDUCTION ZONE

GENERAL NOTES

- . SIGNS FURNISHED BY STATE
- . CONFIRM IN WRITING AT LEAST 4 MONTHS IN ADVANCE, THE ACTUAL DATE THE DEPARTMENT FURNISHED SIGNS WILL BE REQUIRED.
- . ALL TYPE 'D' SIGNS SHALL BE MOUNTED ON TWO U-CHANNEL POSTS UNLESS OTHERWISE INDICATED ON THE PLANS.
- . IF REMOVAL OR RELOCATION OF SIGNS ON PRIVATE STREET (NON-STATE MAINTAINED) IS REQUIRED DUE TO CONSTRUCTION, THE CONTRACTOR SHALL INFORM THE ENGINEER. THE WORK WILL BE COMPLETED BY OTHERS.
- . WHEN NOT STATIONED OR DIMENSIONED ON PLANS, ALL 'E' AND 'F' SIGNS SHALL BE FIELD LOCATED BY THE ENGINEER
- . ALL EXISTING SIGNS ON "U" CHANNEL POST WITHIN THE PROJECT LIMITS SHALL BE REMOVED AND DISPOSED OF UNLESS OTHERWISE NOTED ON PLANS.
- . WHEN EXISTING SIGNS ARE REMOVED AND INSTALLED ON NEW SUPPORTS, THE RE-ERECTION SHALL IMMEDIATELY FOLLOW THE REMOVAL.
- . THE BACKGROUND FOR TYPE E & F SIGNS SHALL BE TYPE C REFLECTIVE SHEETING.
- . DO NOT BEGIN FABRICATION FOR TYPES A & B SIGNS MOUNTED ON OVERHEAD STRUCTURES OR STEEL SUPPORTS UNTIL "S" DIMENSIONS HAVE BEEN FIELD VERIFIED.
- . SEE ROADWAY PLANS FOR GUARD/GUIDE RAIL DETAILS.

SUMMARY OF QUANTITIES

ITEM NO.	ITEM DESCRIPTION		QUANTITY	UNIT
DESC. NO.	SECT. NO.			
4048000000	902	REINFORCED CONCRETE SIGN FOUNDATION	6	C.Y.
4054000000	902	PLAIN CONCRETE SIGN FOUNDATION	1	C.Y.
4060000000	903	SUPPORTS, BREAKAWAY STEEL BEAM	7721	LB.
4072000000	903	SUPPORTS, 3 LB. STEEL U-CHANNEL	1650	L.F.
4096000000	904	SIGN ERECTION, TYPE D	4	EA.
4102000000	904	SIGN ERECTION, TYPE E	67	EA.
4108000000	904	SIGN ERECTION, TYPE F	16	EA.
4110000000	904	SIGN ERECTION, TYPE A (GROUND MOUNTED)	8	EA.
4110000000	904	SIGN ERECTION, TYPE B (GROUND MOUNTED)	6	EA.
4114000000	904	SIGN ERECTION, MILEMARKERS	6	EA.
4116100000	904	SIGN ERECTION, RELOCATE SIGN TYPE E	2	EA.
4155000000	907	DISPOSAL OF SIGN SYSTEM, U-CHANNEL	75	EA.

PROJECT NOTES

- 1 DISPOSAL OF SIGN SYSTEM, U-CHANNEL
- 2 DISPOSAL OF SUPPORT, U-CHANNEL
- 3 RELOCATE SIGN, TYPE E

INDEX

SHEET NO.	DESCRIPTION
SIGN-1	TITLE SHEET
SIGN-2 SERIES	SUPPORT INFORMATION
SIGN-3 SERIES	A, B, AND D SIGN DESIGNS
SIGN-4 SERIES	E AND F SIGNS
SIGN-5-23A	SIGNING DETAIL SHEETS

PLAN REVIEWED BY: N.C.D.O.T. SIGNING AND DELINEATION UNIT

AYMAN ALQUDWAH, PE SIGNING & DELINEATION REGIONAL ENGINEER
 MATTHEW TRACEY, PE SIGNING & DELINEATION PROJECT DESIGN ENGINEER

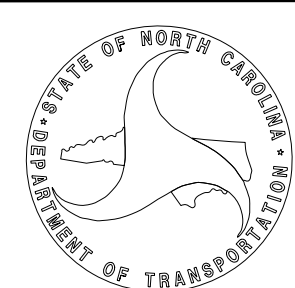

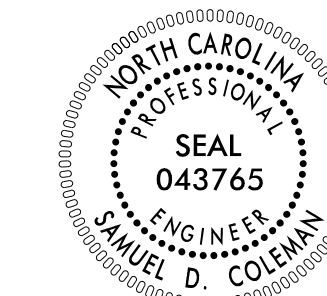

DOCUMENT NOT CONSIDERED FINAL UNLESS ALL SIGNATURES COMPLETED

Version: 3.1 Posted: 6/2/2017

NUMBER	SIGN TYPE	SIGN SIZE (in.)				ROADWAY STATION	NUMBER OF SUPPORTS	BEAM SECTION	SUPPORT TYPE BA or S	OMNI COUPLER	ATTACHMENT METHOD	MOUNTING METHOD	HORIZONTAL CLEARANCE* (ft.)	SUPPORT SPACING	LENGTH (ft)			LEFT SUPPORT (ft)			CENTER SUPPORT (ft)			RIGHT SUPPORT (ft)			SUPPORT WEIGHTS		FOOTINGS				FIELD VERIFIED SEE NOTE 2 (mm/dd/yy)
		w	x	x	h										SNS HT "H"	MTG HT "C"	EMBED- MENT	S	L	LENGTH	S	L	LENGTH	S	L	LENGTH	B/A (lbs.)	SIMPLE (lbs.)	DIAMETER (ft.)	DEPTH (ft.)	REINFORCED (c.y.)	PLAIN (c.y.)	
101A	B	132	x	30	See SIGN-5	3	W6x16	BA	N/A	1-R	N/A	30.00	6.92	6.00	7.00	4.0	3.30	16.30	20.30	4.30	17.30	21.30	5.50	18.50	22.50	1166.60	0	1.5	4.5	0.88	0.00	_____	
101B	A	234	x	72																													
102A	B	132	x	30	See SIGN-6	3	W6x16	BA	N/A	1-R	N/A	30.00	6.92	6.00	7.00	4.0	3.40	16.40	20.40	4.10	17.10	21.10	5.04	18.04	22.04	1157.64	0	1.5	4.5	0.88	0.00	_____	
102B	A	234	x	72																													
103A	B	132	x	30	-LEB- STA 29+20	3	W6x16	BA	N/A	1-R	N/A	30.00	6.92	7.50	7.00	4.0	3.42	17.92	21.92	4.60	19.10	23.10	5.84	20.34	24.34	1250.76	0	1.5	4.5	0.88	0.00	_____	
103B	A	234	x	90																													
104A	B	132	x	30	-L- STA 43+77	3	W6x16	BA	N/A	1-R	N/A	30.00	6.92	7.50	7.00	4.0	3.60	18.10	22.10	5.15	19.65	23.65	5.55	20.05	24.05	1257.80	0	1.5	4.5	0.88	0.00	_____	
104B	A	234	x	90																													
105A	B	132	x	30	-L- STA 71+00	3	W6x16	BA	N/A	1-R	N/A	30.00	6.92	6.00	7.00	4.0	3.75	16.75	20.75	4.94	17.94	21.94	6.15	19.15	23.15	1194.44	0	1.5	4.5	0.88	0.00	_____	
105B	A	234	x	72																													
106A	B	132	x	30	-L- STA 97+50	3	W6x16	BA	N/A	1-R	N/A	30.00	6.92	6.00	7.00	4.0	4.75	17.75	21.75	6.48	19.48	23.48	8.20	21.20	25.20	1267.88	0	1.5	4.5	0.88	0.00	_____	
106B	A	234	x	72																													
201	A	96	x	60	-LEB- STA 37+67	2	S3x5.7	BA	N/A	N/A	N/A	Δ	4.69	5.00	7.00	2.5	1.00	13.00	15.50	0.00	0.00	0.00	1.00	13.00	15.50	212.70	0	1.0	3	0.00	0.17	_____	
202	A	96	x	60	-L- STA 35+31	2	S3x5.7	BA	N/A	N/A	N/A	Δ	4.69	5.00	7.00	2.5	1.00	13.00	15.50	0.00	0.00	0.00	1.00	13.00	15.50	212.70	0	1.0	3	0.00	0.17	_____	

TOTAL	7720.52	TOTAL	0.00	TOTAL	5.30	TOTAL	0.35
USE:	7721.00		0.00		6.00		1.00

NOTES

- DIMENSION "S" REPRESENTS AN INCREASE (+), OR A DECREASE (-) IN POLE LENGTH, RELATIVE TO THE ELEVATION OF THE EDGE OF TRAVEL LANE.
- FIELD VERIFICATIONS SHALL BE REQUIRED FOR ALL SUPPORTS, SEE (*) ARTICLE 903-3. FABRICATORS SHALL BE AISC CERTIFIED IN CATEGORY 1, SEE (*) ARTICLE 1072-1. (*) = N.C.D.O.T. STANDARD SPECIFICATIONS FOR ROADS AND STRUCTURES
- PLAN LOCATIONS FOR EXISTING UTILITIES ARE BASED ON THE BEST AVAILABLE INFORMATION AND, MAY NOT BE PRECISELY ACCURATE. THEREFORE, IT IS INCUMBENT UPON THE CONTRACTOR TO DETERMINE THE EXACT LOCATION OF UTILITIES BEFORE BEGINNING WORK IN A LOCATION.

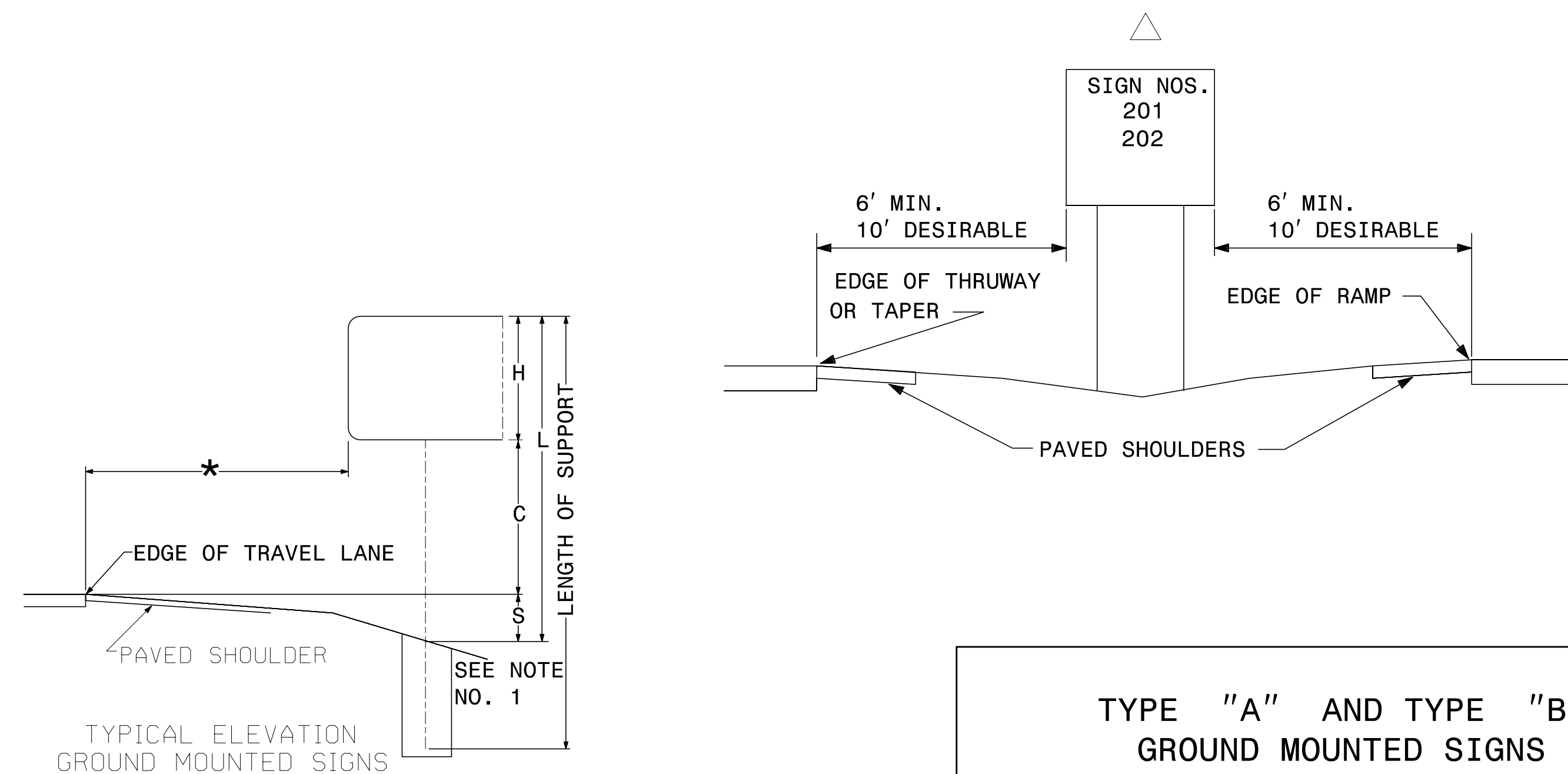

TYPE "A" AND TYPE "B" GROUND MOUNTED SIGNS

M
M
 MOTT
 MACDONALD
 NC LICENSE NO. F-0669

MOTT MACDONALD I & E, LLC
 1101 HAYNES STREET, SUITE 101
 RALEIGH, NC 27604

SIGN NUMBER: 301, 302 TYPE: D QUANTITY: 2 SIGN WIDTH: 7'-0" HEIGHT: 2'-6" TOTAL AREA: 17.5 Sq.Ft. BORDER TYPE: FLUSH RECESS: 0" WIDTH: 1" RADII: 3" NO. Z BARS: LENGTH:	BACKG COLOR: Green COPY COLOR: White SYMBOL X Y WID HT AR_Type D 67.4 12 6 9 MAT'L: 0.125" (3.2 mm) ALUMINUM	DESIGN BY: S Coleman PROJECT ID: R-5819/5820 CHECKED BY: LOCATION: Lake Waccamaw Feb 04, 2021 DIV: 6
--	--	---

USE NOTES:
 1. Legend and border (except those that are colored black) shall be direct applied Grade C sheeting.
 2. Background shall be Grade C reflective sheeting.

Spacing Factor is 1 unless specified otherwise

LETTER POSITIONS

Letter spacings are to start of next letter													Series/Size
E	a	s	t	C	o	i	u	m	b	u	s		D 2000
7.6	11.9	16.1	19.2	26.1	31.1	35.8	37.9	42.6	49.7	54.2	58.6		53.8
H	i	g	h	S	c	h	o	o	l				D 2000
12.7	18.1	20	24.8	32.8	37.6	41.9	46.3	50.7	55.3				43.6

FILENAME: Sign Designs NORTH CAROLINA D.O.T. SIGN DETAIL

SIGN NUMBER: 303 TYPE: D QUANTITY: 1 SIGN WIDTH: 7'-0" HEIGHT: 3'-6" TOTAL AREA: 24.5 Sq.Ft. BORDER TYPE: FLUSH RECESS: 0" WIDTH: 0.75" RADII: 2.25" NO. Z BARS: LENGTH:	BACKG COLOR: Green / Green COPY COLOR: White SYMBOL X Y WID HT AR_FISHOOK 3.3 27.3 9.9 10.8 AR_Type D 67.4 9.1 6 9 MAT'L: 0.125" (3.2 mm) ALUMINUM	DESIGN BY: S Coleman PROJECT ID: R-5819/5820 CHECKED BY: LOCATION: Lake Waccamaw Feb 04, 2021 DIV: 6
---	---	---

USE NOTES:
 1. Legend and border (except those that are colored black) shall be direct applied Grade C sheeting.
 2. Background shall be Grade C reflective sheeting.

Spacing Factor is 1 unless specified otherwise

LETTER POSITIONS

Letter spacings are to start of next letter													Series/Size
L	o	k	e	W	a	c	c	a	m	a	w		D 2000
19.2	23.4	27.9	32.3	40.3	46.1	50.4	54.5	58.5	63.1	69.9	74		61.6
E	a	s	t	C	o	i	u	m	b	u	s		D 2000
7.6	11.9	16.1	19.2	26.1	31.1	35.8	37.9	42.6	49.7	54.2	58.6		53.8
H	i	g	h	S	c	h	o	o	l				D 2000
12.7	18.1	20	24.8	32.8	37.6	41.9	46.3	50.7	55.3				43.6

FILENAME: Sign Designs NORTH CAROLINA D.O.T. SIGN DETAIL

SIGN NUMBER: 304 TYPE: D QUANTITY: 1 SIGN WIDTH: 7'-0" HEIGHT: 3'-6" TOTAL AREA: 24.5 Sq.Ft. BORDER TYPE: FLUSH RECESS: 0" WIDTH: 0.75" RADII: 2.25" NO. Z BARS: LENGTH:	BACKG COLOR: Green / Green COPY COLOR: White SYMBOL X Y WID HT AR_FISHOOK 7.2 23.3 9.9 10.8 AR_Type D 71.3 5.1 6 9 MAT'L: 0.125" (3.2 mm) ALUMINUM	DESIGN BY: S Coleman PROJECT ID: R-5819/5820 CHECKED BY: LOCATION: Lake Waccamaw Feb 04, 2021 DIV: 6
---	---	---

USE NOTES:
 1. Legend and border (except those that are colored black) shall be direct applied Grade C sheeting.
 2. Background shall be Grade C reflective sheeting.

Spacing Factor is 1 unless specified otherwise

LETTER POSITIONS

Letter spacings are to start of next letter													Series/Size
E	a	s	t	C	o	i	u	m	b	u	s		D 2000
23.1	27.4	31.6	34.7	41.6	46.6	51.2	53.3	58.1	65.1	69.6	74		53.8
H	i	g	h	S	c	h	o	o	l				D 2000
28.1	33.5	35.5	40.3	48.3	53	57.4	61.8	66.2	70.8				43.6
L	o	k	e	W	a	c	c	a	m	a	w		D 2000
3.7	7.9	12.5	16.8	24.8	30.7	35	39.1	43.1	47.6	54.4	58.5		61.6

FILENAME: Sign Designs NORTH CAROLINA D.O.T. SIGN DETAIL

SIGN NUMBER: 101A, 102A, 103A, 104A, 105A, 106A TYPE: B QUANTITY: 1 SIGN WIDTH: 11'-0" HEIGHT: 2'-6" TOTAL AREA: 27.5 Sq.Ft. BORDER TYPE: FLUSH RECESS: 0" WIDTH: 2" RADII: 3" NO. Z BARS: 2 LENGTH: 124.0	BACKG COLOR: Green COPY COLOR: White SYMBOL X Y WID HT MAT'L: 0.125" (3.2 mm) ALUMINUM	DESIGN BY: S Coleman PROJECT ID: R-5819/5820 CHECKED BY: LOCATION: Lake Waccamaw Mar 25, 2022 DIV: 6
---	---	---

USE NOTES:
 1. Legend and border (except those that are colored black) shall be direct applied Grade C sheeting.
 2. Background shall be Grade C reflective sheeting.

Spacing Factor is 1.2 for the word "EXIT"
 Spacing Factor is 1 unless specified otherwise

LETTER POSITIONS

Letter locations are panel edge to lower left corner					Series/Size
E	X	I	T		E 2000
22.4	31.5	42.6	46.5		31.6
2	5	2			E 2000
69	83.2	97.5			40.7

FILENAME: Sign Designs NORTH CAROLINA D.O.T. SIGN DETAIL

4/14/2022
 G:\501406565_Calyx_R5820\IR-5819_R-5820\Traffic\Signing_Layout\Plans\IR-5819_R-5820_Sgn_SGN_3A.dgn
 User:COL85144

APPROVED: _____ DATE: _____			SIGN DESIGNS
DOCUMENT NOT CONSIDERED FINAL UNLESS ALL SIGNATURES COMPLETED			

401 QUANTITY REQ'D 1

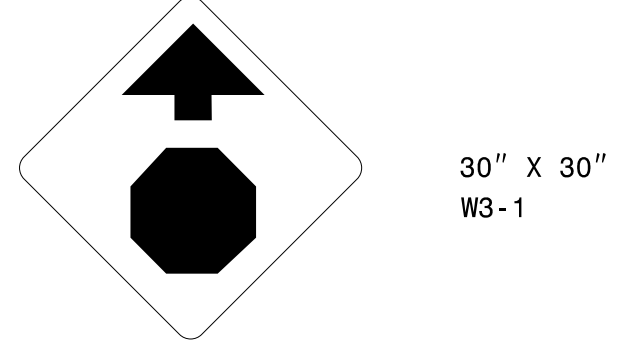

30" X 30"
W3-1

ONE "U" POST PER SIGN

402 QUANTITY REQ'D 2

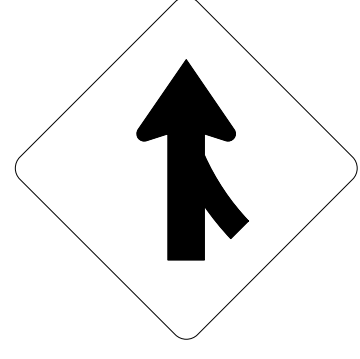

48" X 48"
W4-1

TWO "U" POSTS PER SIGN

403 QUANTITY REQ'D 8

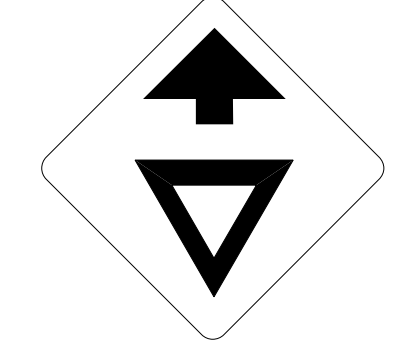

30" X 30"
W3-2

ONE "U" POST PER SIGN

404 QUANTITY REQ'D 10

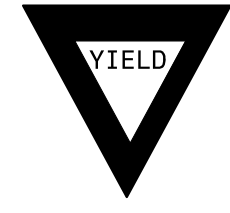

36" X 36" X 36"
R1-2

ONE "U" POST PER SIGN

405 QUANTITY REQ'D 4



24" X 8"
S4-3P

YELLOW/GREEN REFLECTIVE SHEETING

MOUNTED ABOVE SIGN 410
IN 2 INSTALLATIONS
MOUNTED BELOW SIGN 415
IN 2 INSTALLATIONS

406 QUANTITY REQ'D 5

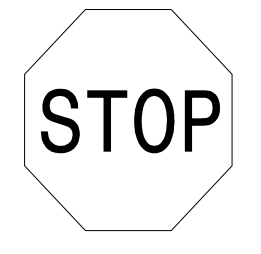

36" X 36"
R1-1

ONE "U" POST PER SIGN

407 QUANTITY REQ'D 10

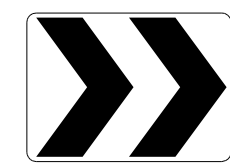

30" X 24"
R6-4

ONE "U" POST PER SIGN

408 QUANTITY REQ'D 2

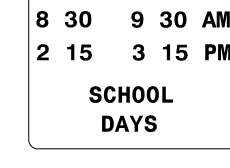

24" X 16"
S4-1P

MOUNTED BELOW SIGN 410
IN 2 INSTALLATIONS

409 QUANTITY REQ'D 4

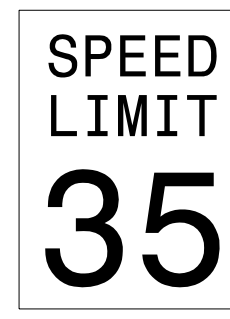

24" X 30"
R2-1

ONE "U" POST PER SIGN

410 QUANTITY REQ'D 2



24" X 30"
R2-1

ONE "U" POST PER SIGN

411 QUANTITY REQ'D 2



48" X 60"
R2-1

TWO "U" POSTS PER SIGN

412 QUANTITY REQ'D 2



36" X 36"
W3-5

ONE "U" POST PER SIGN

413 QUANTITY REQ'D 4

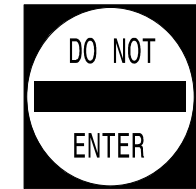

30" X 30"
R5-1

ONE "U" POST PER SIGN

414 QUANTITY REQ'D 4

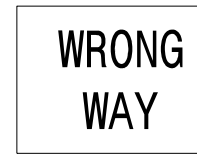

36" X 24"
R5-1a

ONE "U" POST PER SIGN

415 QUANTITY REQ'D 2



36" X 36"
S1-1

YELLOW/GREEN REFLECTIVE SHEETING

ONE "U" POST PER SIGN

416 QUANTITY REQ'D 1



30" X 30"
W11-2

YELLOW/GREEN REFLECTIVE SHEETING

ONE "U" POST PER SIGN

417 QUANTITY REQ'D 1

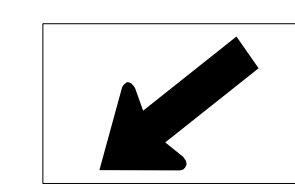

24" X 12"
W16-7

YELLOW/GREEN REFLECTIVE SHEETING

MOUNT BELOW SIGN 416
IN 1 INSTALLATIONS

418 QUANTITY REQ'D 1

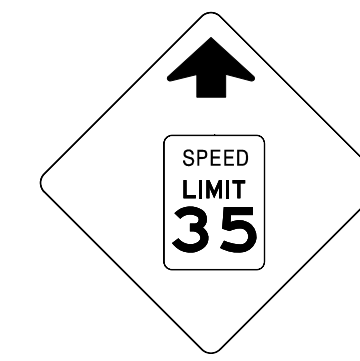

36" X 36"
W3-5

ONE "U" POST PER SIGN

419 QUANTITY REQ'D 2

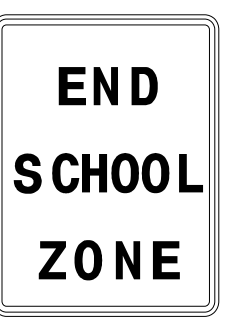

24" X 30"
S5-2

ONE "U" POST PER SIGN

QUANTITY REQ'D 2

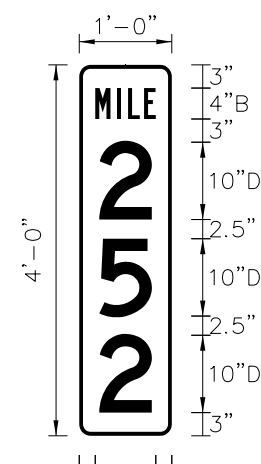

D10-3
12" X 48"

BORDER R=1.5" TH=0.5"

ONE 3 LB. "U" POST PER SIGN

QUANTITY REQ'D 2

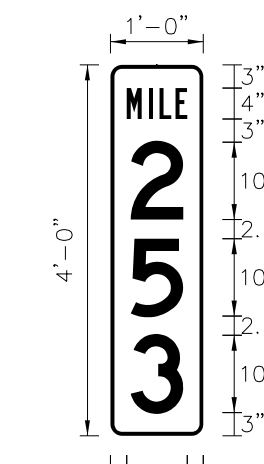

D10-3
12" X 48"

BORDER R=1.5" TH=0.5"

ONE 3 LB. "U" POST PER SIGN

QUANTITY REQ'D 2

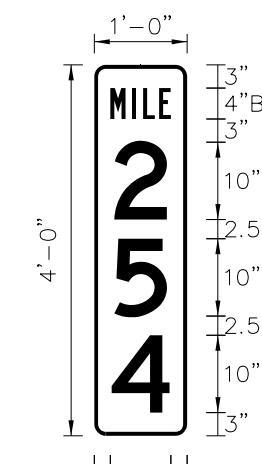

D10-3
12" X 48"

BORDER R=1.5" TH=0.5"

ONE 3 LB. "U" POST PER SIGN

APPROVED: _____
 DATE: _____

**DOCUMENT NOT CONSIDERED FINAL
UNLESS ALL SIGNATURES COMPLETED**

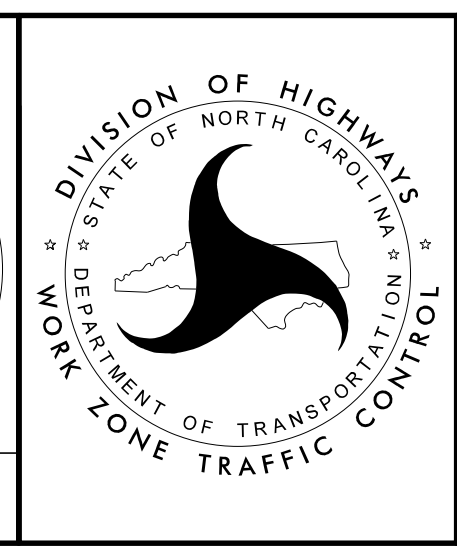

TYPE 'E' SIGNS
& MILEMARKERS

501

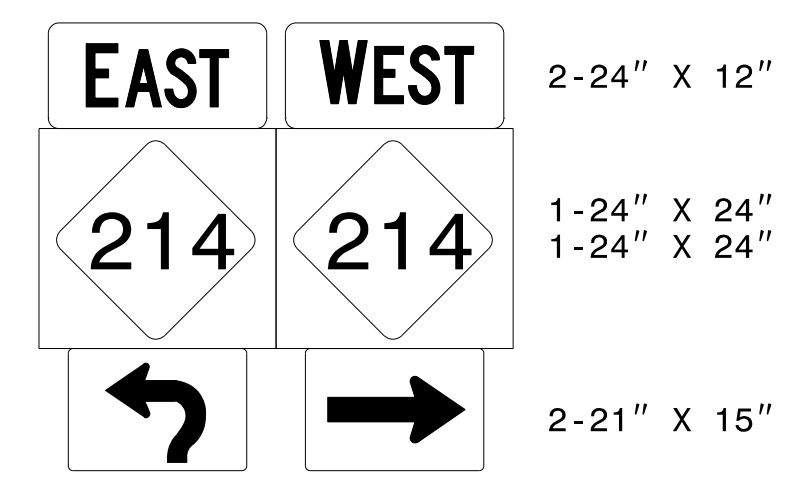

TWO "U" POSTS PER SIGN

502

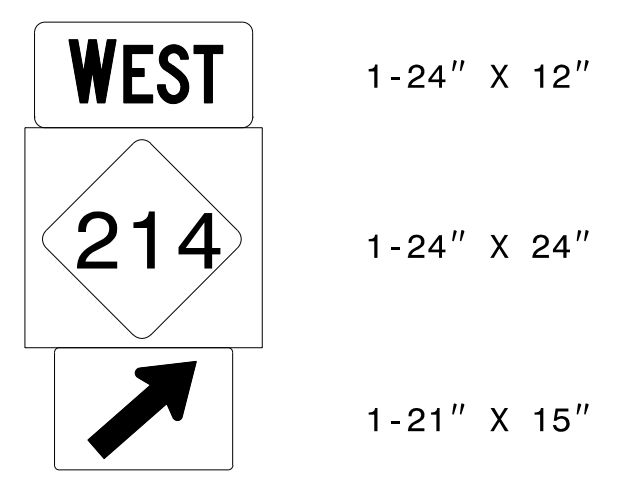

ONE "U" POST PER SIGN

503 516

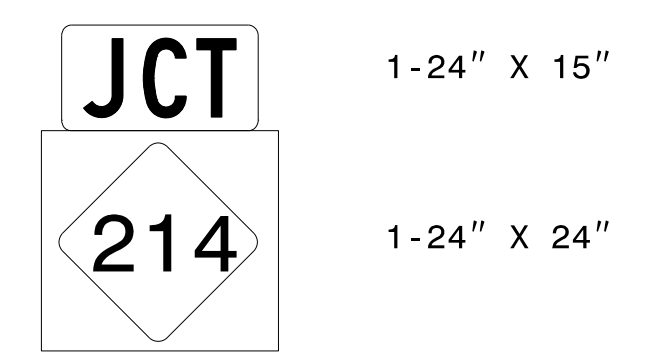

ONE "U" POST PER SIGN

504

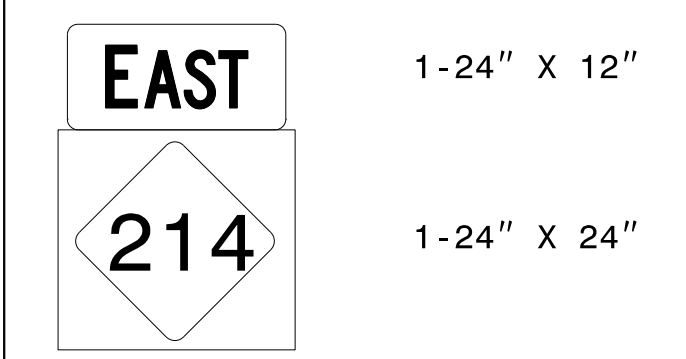

ONE "U" POST PER SIGN

505

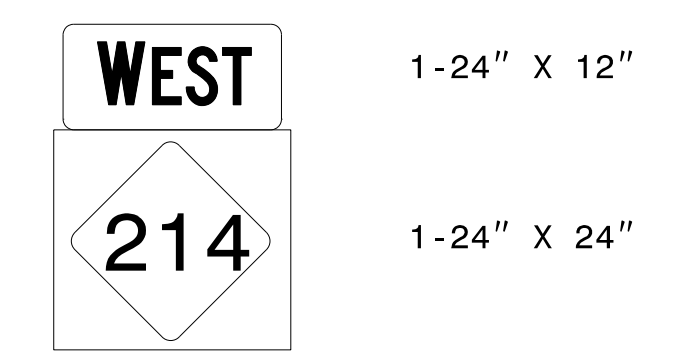

ONE "U" POST PER SIGN

506

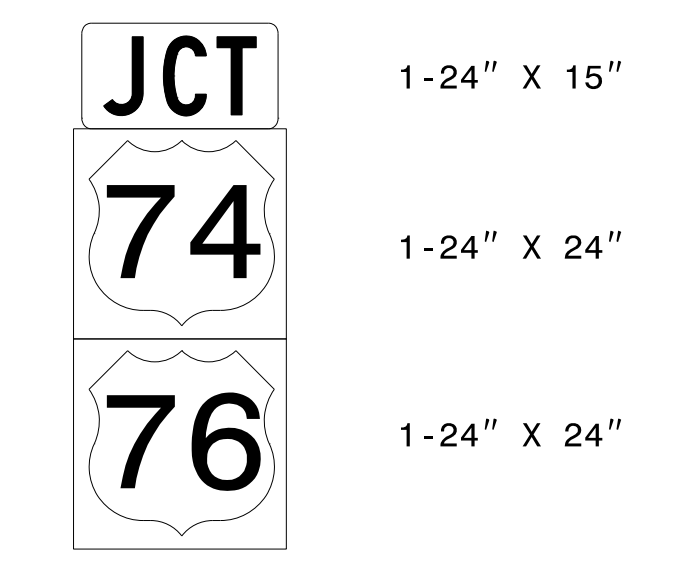

ONE "U" POST PER SIGN

507

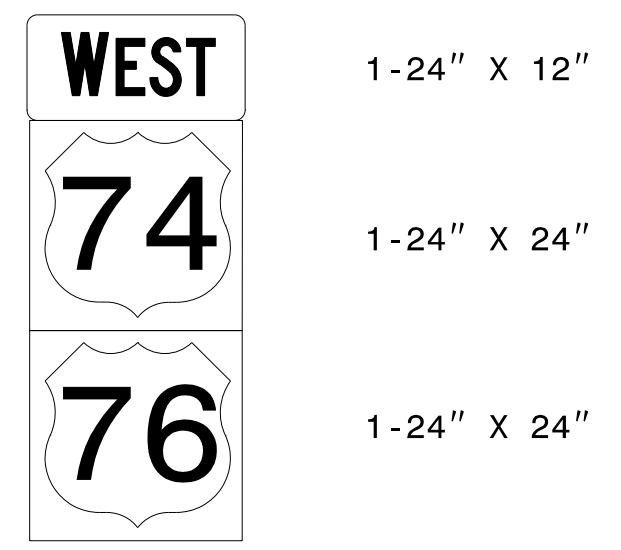

ONE "U" POST PER SIGN

508

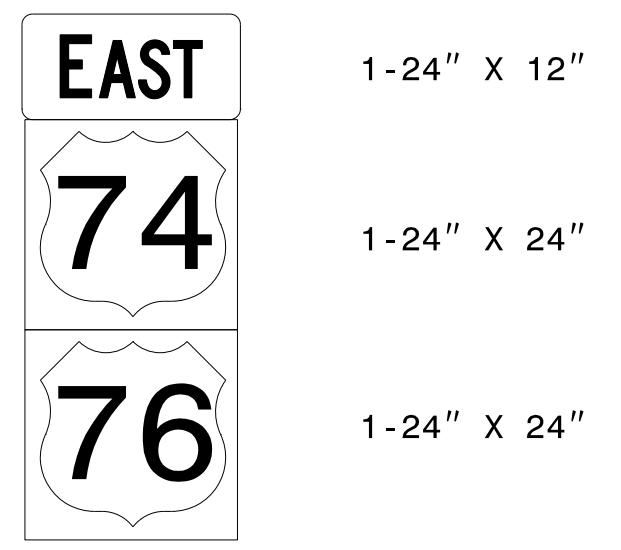

ONE "U" POST PER SIGN

509

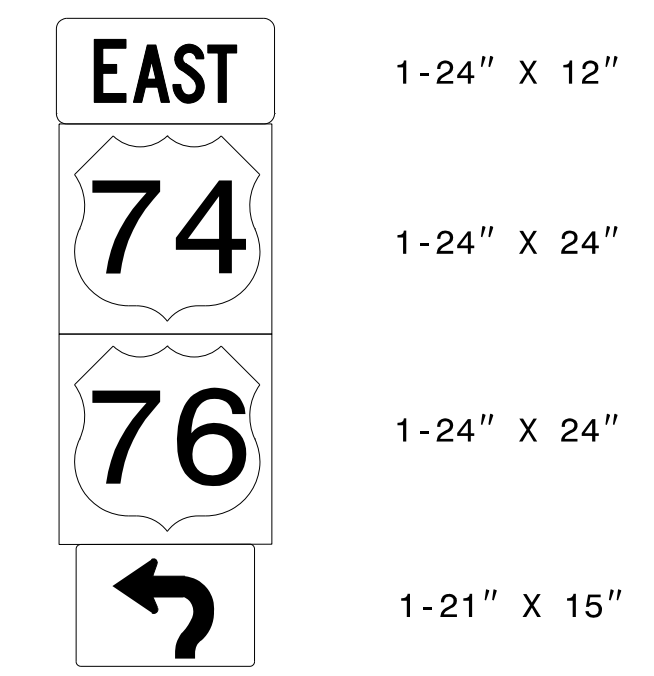

ONE "U" POST PER SIGN

510

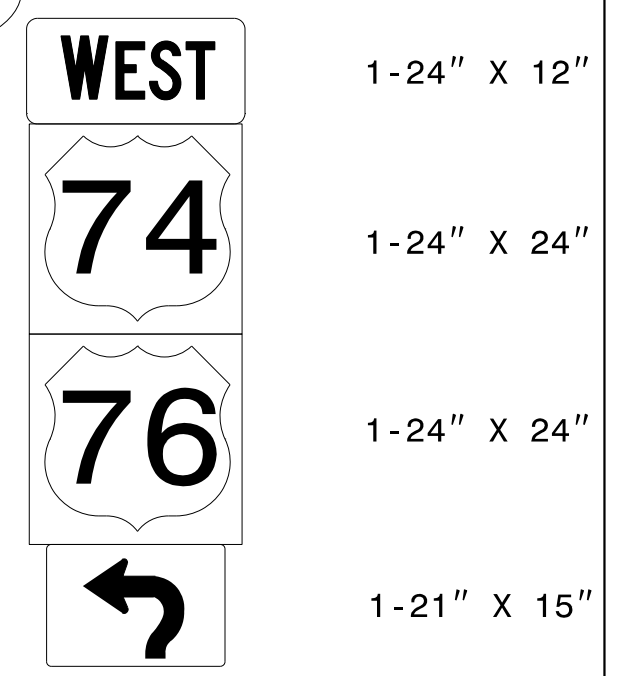

ONE "U" POST PER SIGN

511

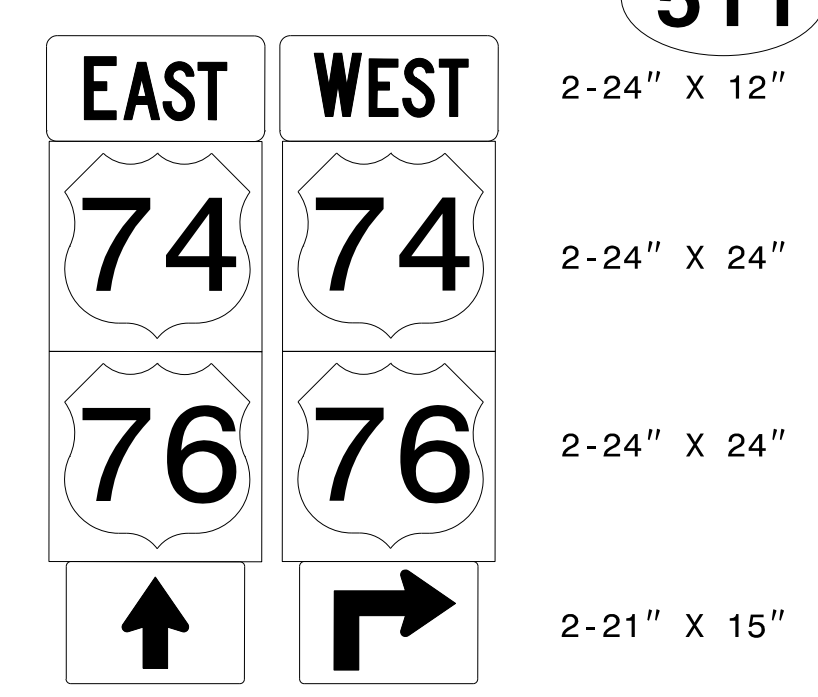

TWO "U" POSTS PER SIGN

512

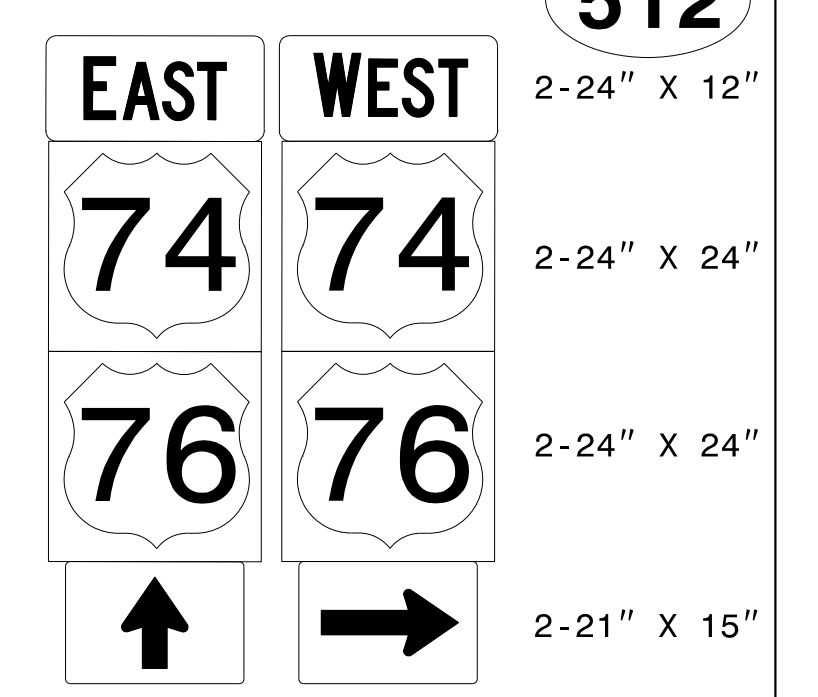

TWO "U" POSTS PER SIGN

513

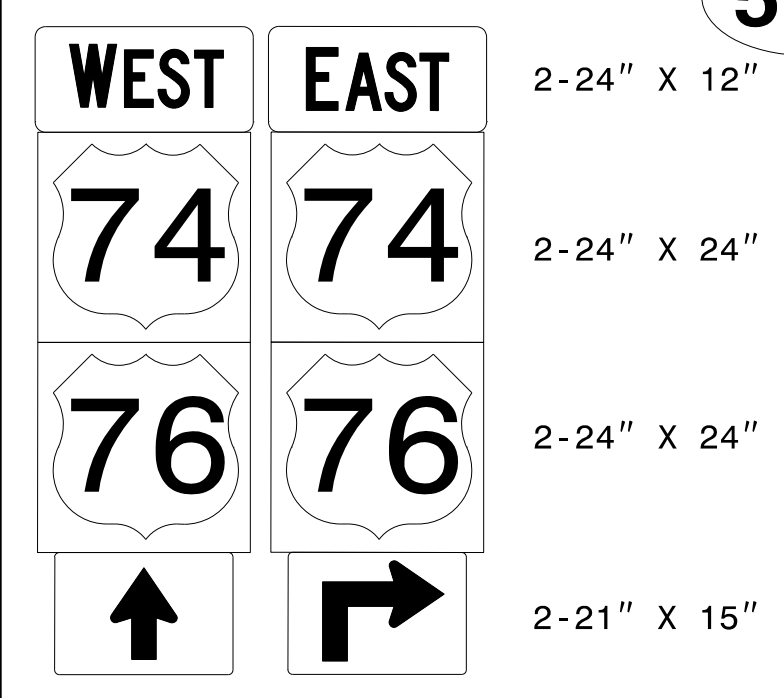

TWO "U" POSTS PER SIGN

514

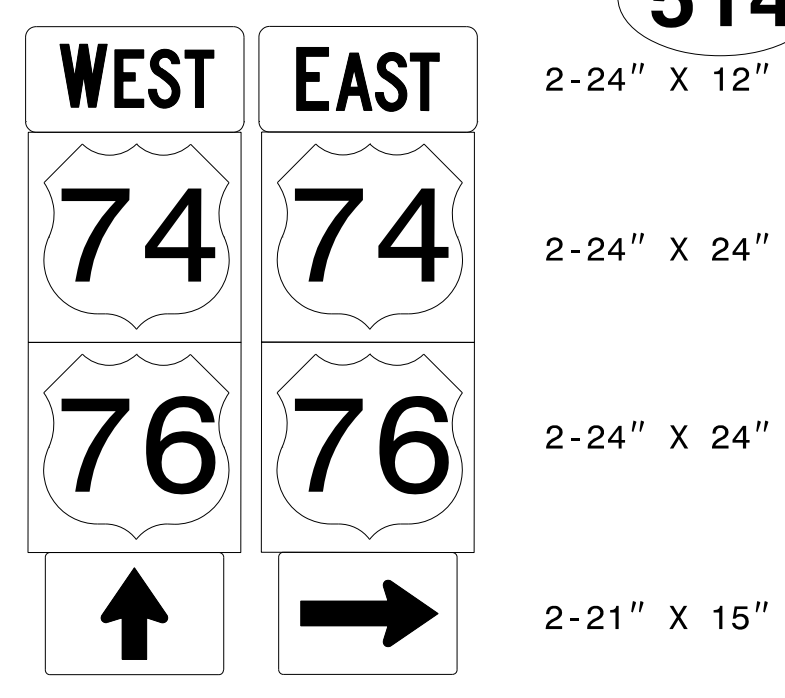

TWO "U" POSTS PER SIGN

515

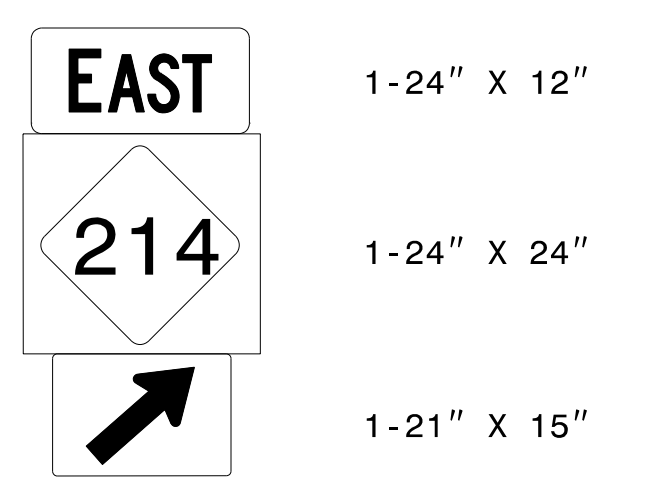

ONE "U" POST PER SIGN

APPROVED: _____
 DATE: _____

**DOCUMENT NOT CONSIDERED FINAL
 UNLESS ALL SIGNATURES COMPLETED**

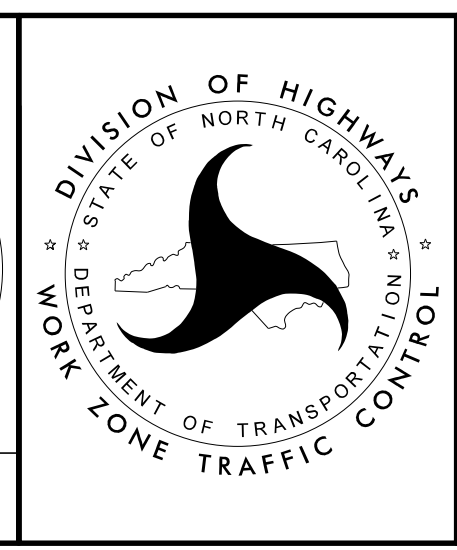

TYPE 'F' SIGNS

PLANS PREPARED FOR THE NCDOT BY:

M MOTT MACDONALD I & E, LLC
 1101 HAYNES STREET, SUITE 101
 RALEIGH, NC 27604
M MOTT MACDONALD NC LICENSE NO. F-0669

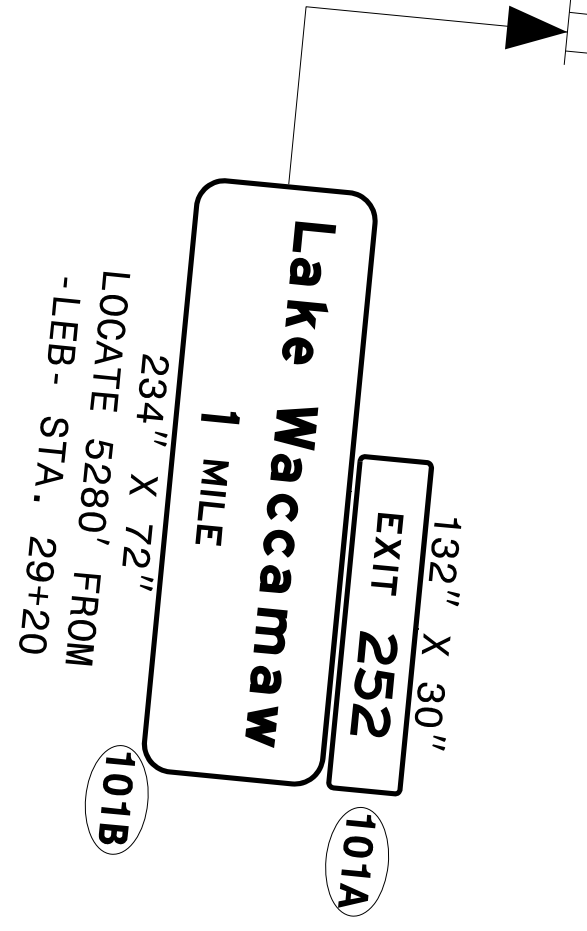
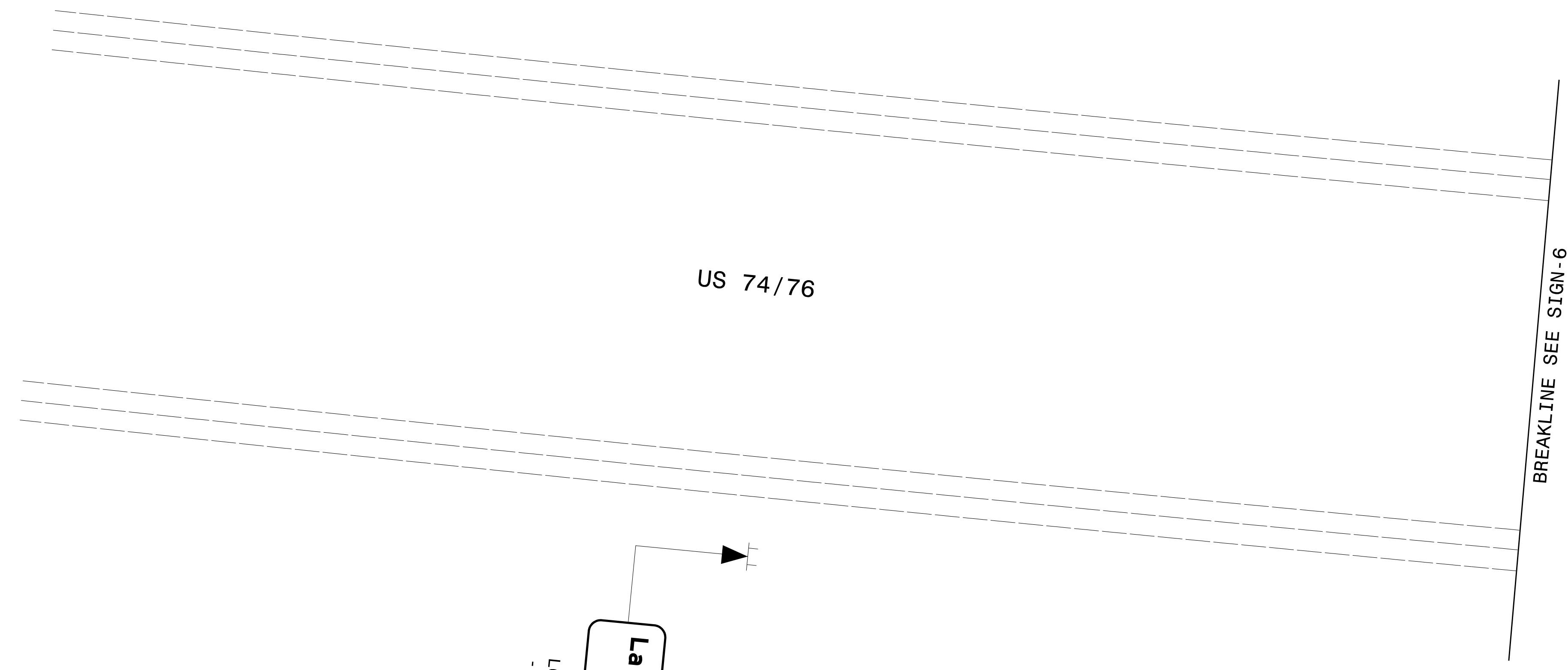

4/14/2022
 G:\50406565_Calyx_R5819_R5820\Tr-offic\Signing\CADD\Signing Layout Plans\R-5819 R-5820_Sgn_SGN_5.dgn
 User:COLL85144

APPROVED: _____ DATE: _____ SEAL			<p>PROPOSED SIGNING DETAIL SHEET</p>
<p>DOCUMENT NOT CONSIDERED FINAL UNLESS ALL SIGNATURES COMPLETED</p>			

PLANS PREPARED FOR THE NCDOT BY:

M MOTT MACDONALD I & E, LLC
 1101 HAYNES STREET, SUITE 101
 RALEIGH, NC 27604
M MOTT MACDONALD NC LICENSE NO. F-0669

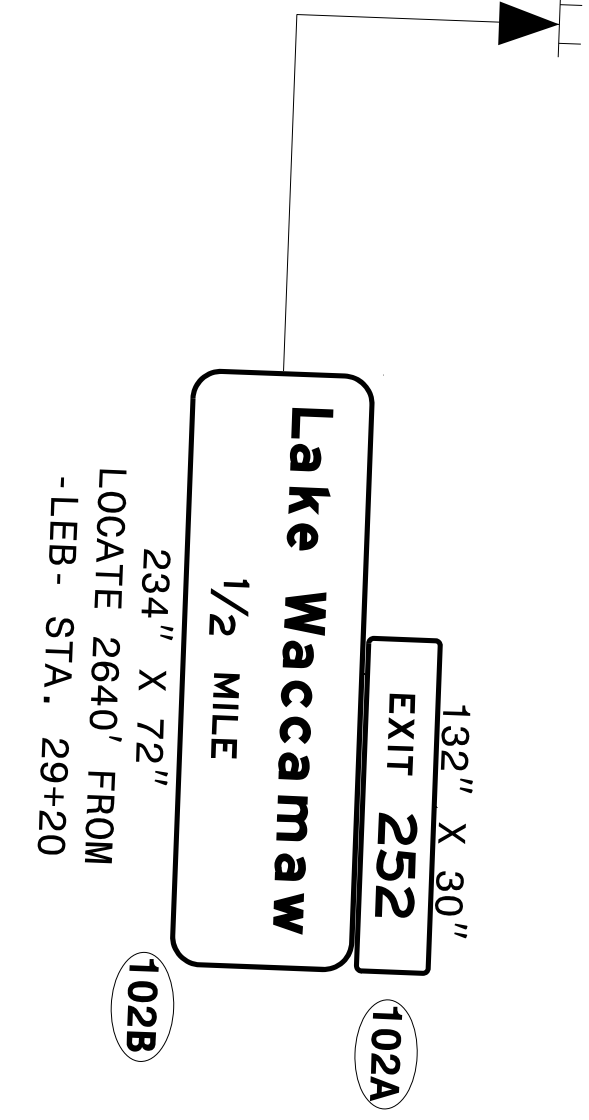
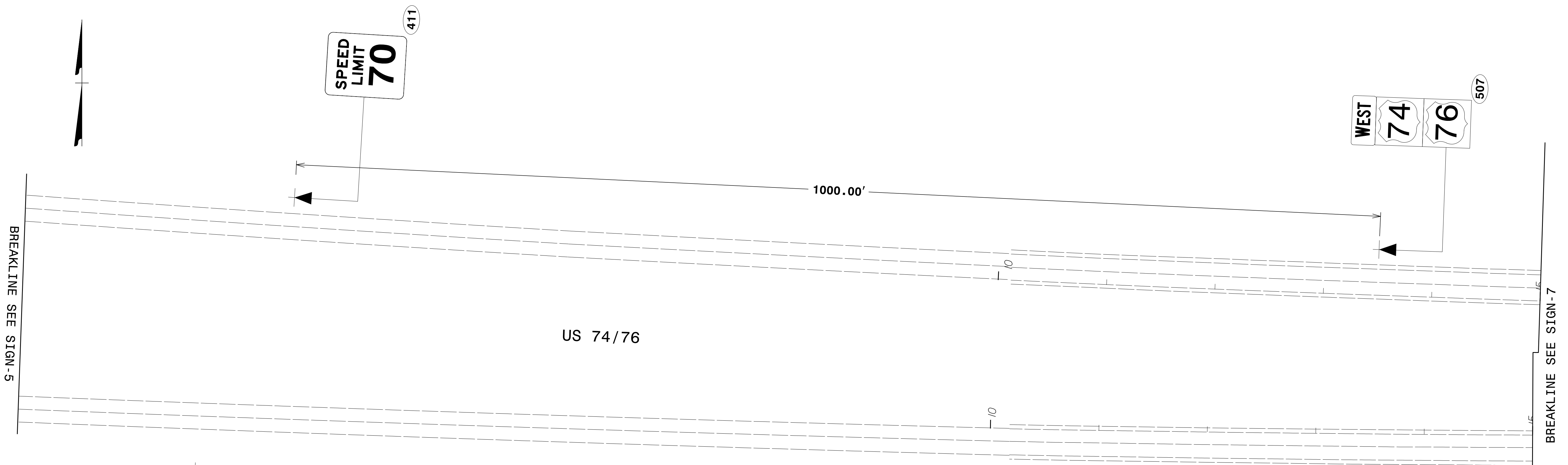

4/14/2022
 G:\501406565_Calyx_R5819_R5820\Traffic\Signing\CADD\Signing Layout Plans\R-5819 R-5820_Sgn_SGN-6.dgn
 User:COL85144



APPROVED: _____ DATE: _____ SEAL			<p style="text-align: center;">PROPOSED SIGNING DETAIL SHEET</p>
<p>DOCUMENT NOT CONSIDERED FINAL UNLESS ALL SIGNATURES COMPLETED</p>			

PLANS PREPARED FOR THE NCDOT BY:

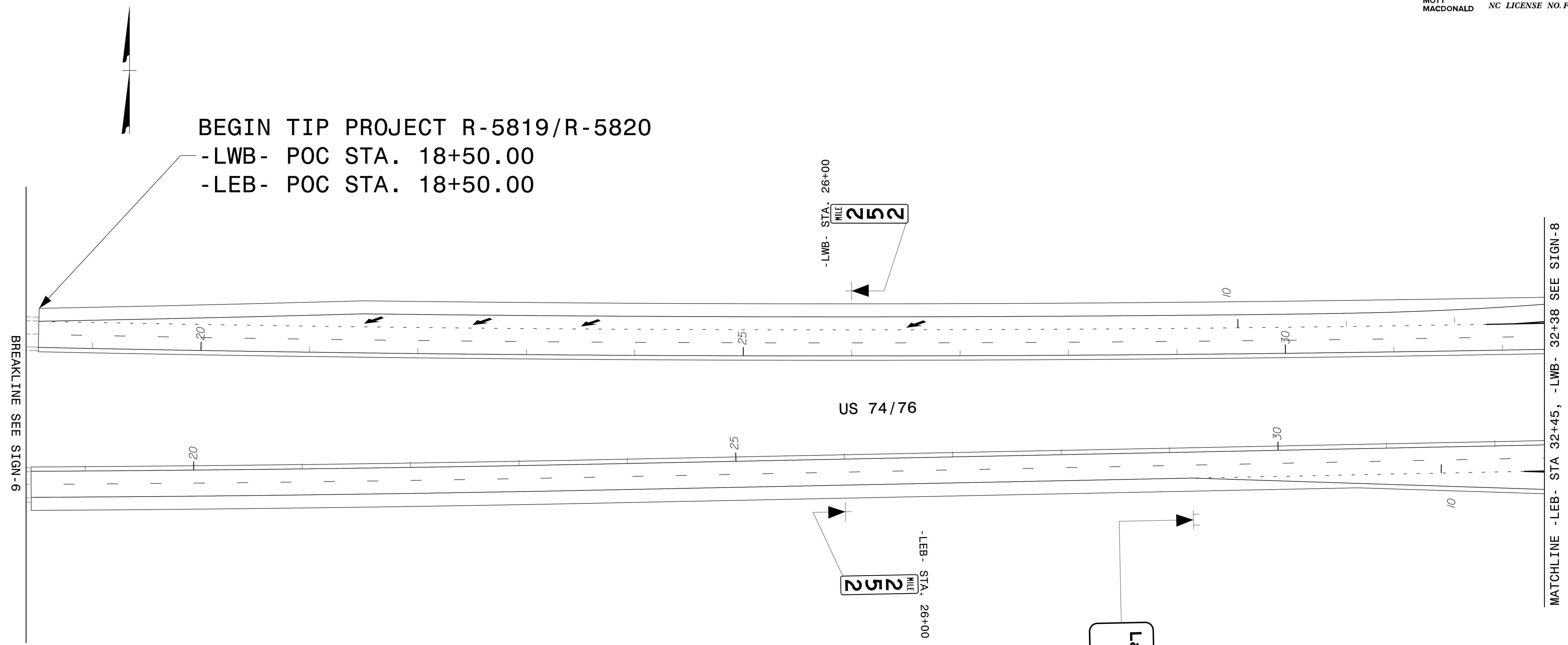
M MOTT MACDONALD I & E, LLC
 1101 HAYNES STREET, SUITE 101
 RALEIGH, NC 27604
M MOTT MACDONALD NC LICENSE NO. F-0669

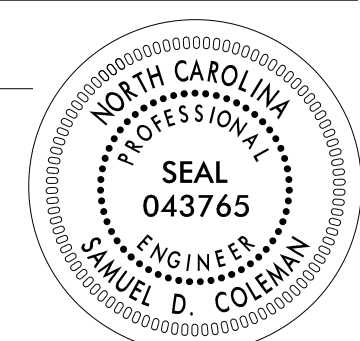

4/14/2022
 G:\50406565_Calyx_R5819_R5820\Tr-afflic\Signing\CADD\Signing_Layout_Plans\R-5819_R-5820_Sgn_Sgn_7.dgn
 User:COL85144

APPROVED: _____ DATE: _____ SEAL	 	<p>PROPOSED SIGNING DETAIL SHEET</p>
<p>DOCUMENT NOT CONSIDERED FINAL UNLESS ALL SIGNATURES COMPLETED</p>		

PLANS PREPARED FOR THE NCDOT BY:

M
MOTT
MACDONALD

MOTT MACDONALD I & E, LLC
1101 HAYNES STREET, SUITE 101
RALEIGH, NC 27604
NC LICENSE NO. F-0669

PROJ. REFERENCE NO.	SHEET NO.
R-5819 R-5820	SIGN-8

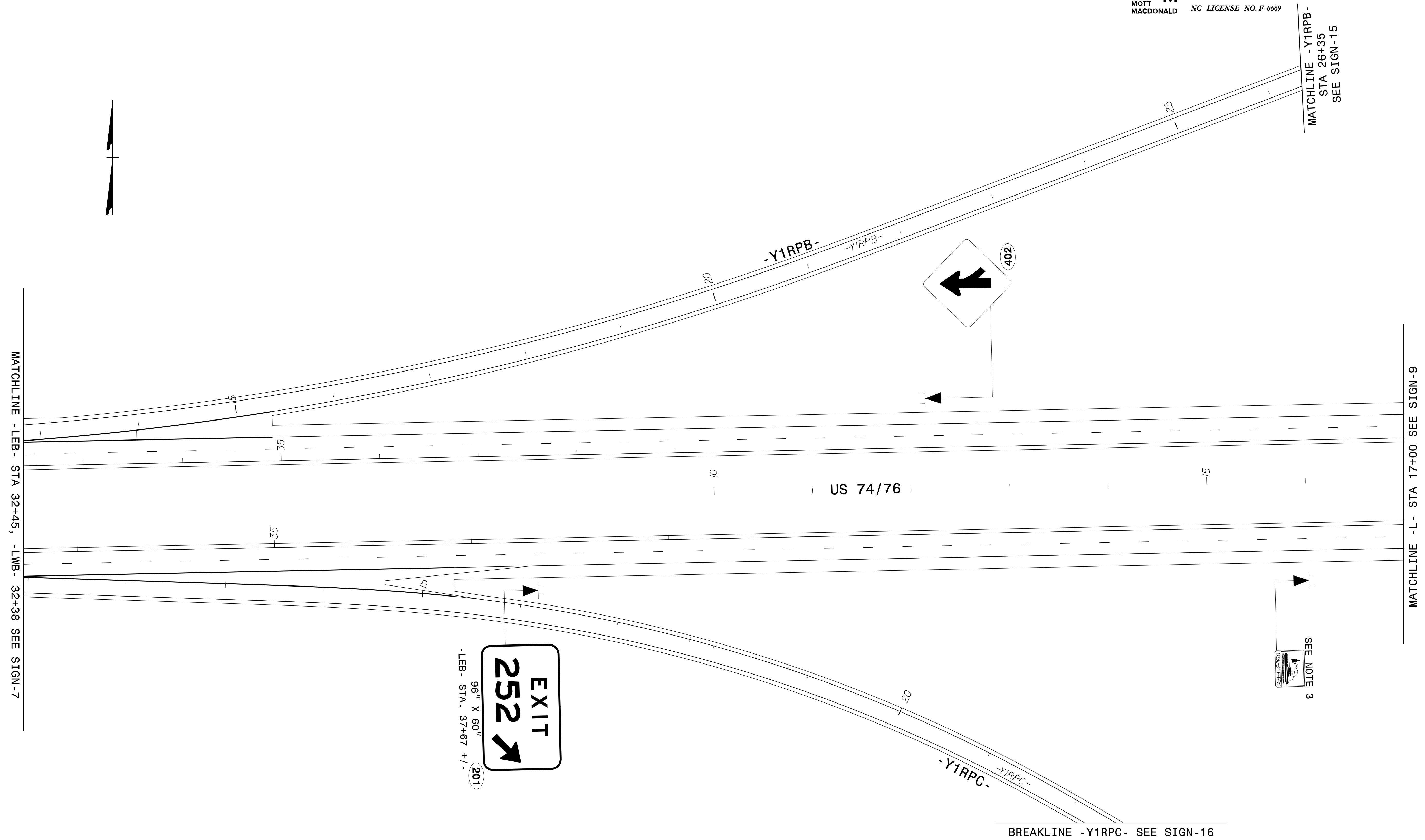

MATCHLINE - LEB - STA 32+45, -LWB- 32+38 SEE SIGN-7

MATCHLINE - L - STA 17+00 SEE SIGN-9

MATCHLINE -Y1RPB-
STA 26+35
SEE SIGN-15

96" X 60"
-LEB- STA. 37+67 +/-
252
EXIT
201

SEE NOTE 3

BREAKLINE -Y1RPC- SEE SIGN-16

APPROVED: _____
DATE: _____

SEAL

SEAL
NORTH CAROLINA
PROFESSIONAL
ENGINEER
SAMUEL D. COLEMAN
043765

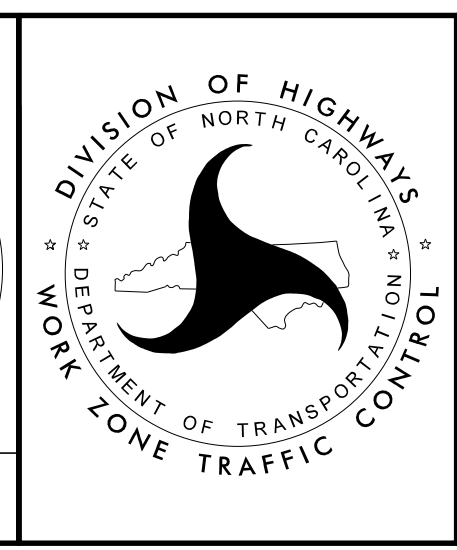

PROPOSED
SIGNING DETAIL SHEET

DOCUMENT NOT CONSIDERED FINAL
UNLESS ALL SIGNATURES COMPLETED

4/14/2022
G:\50406565_Calyx_R5819_R5820\Tr\affic\Signing\CA00\Signing Layout Plans\R-5819_R-5820_Sgn_SGN_8.dgn
User:COL85144



PROJ. REFERENCE NO.	SHEET NO.
R-5819 R-5820	SIGN-8A

PLANS PREPARED FOR THE NCDOT BY:

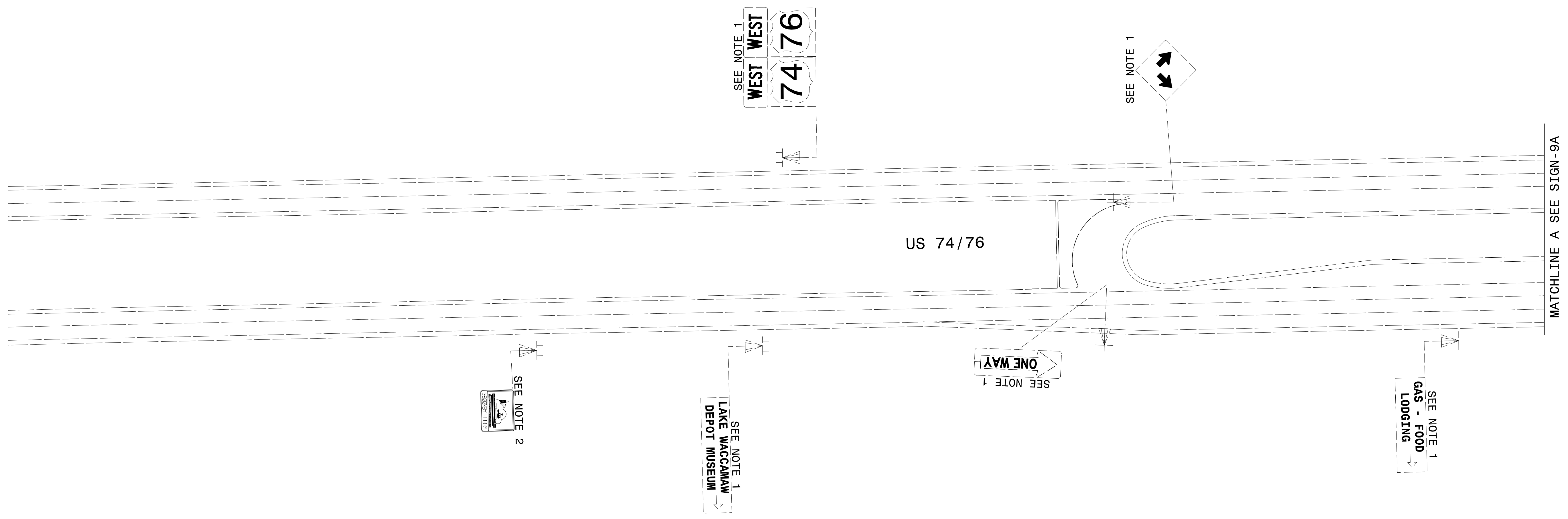
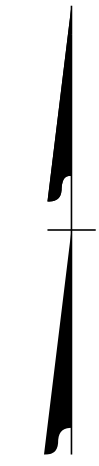
M MOTT MACDONALD I & E, LLC
 1101 HAYNES STREET, SUITE 101
 RALEIGH, NC 27604
M MOTT MACDONALD NC LICENSE NO. F-0669

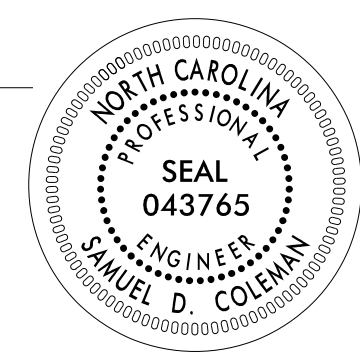

4/14/2022
 G:\50406565_Calyx_R5819_R5820\Tr-offic\Signing\CADD\Signing Layout Plans\R-5819_R-5820_Sgn_Sgn_8a.dgn
 User:COL85144

APPROVED: _____ DATE: _____ SEAL 		<p>EXISTING SIGNING DETAIL SHEET</p>
<p>DOCUMENT NOT CONSIDERED FINAL UNLESS ALL SIGNATURES COMPLETED</p>		

PLANS PREPARED FOR THE NCDOT BY:

M MOTT MACDONALD I & E, LLC
 1101 HAYNES STREET, SUITE 101
 RALEIGH, NC 27604
M MOTT MACDONALD NC LICENSE NO. F-0669

BREAKLINE -Y1RPA- SEE SIGN-15

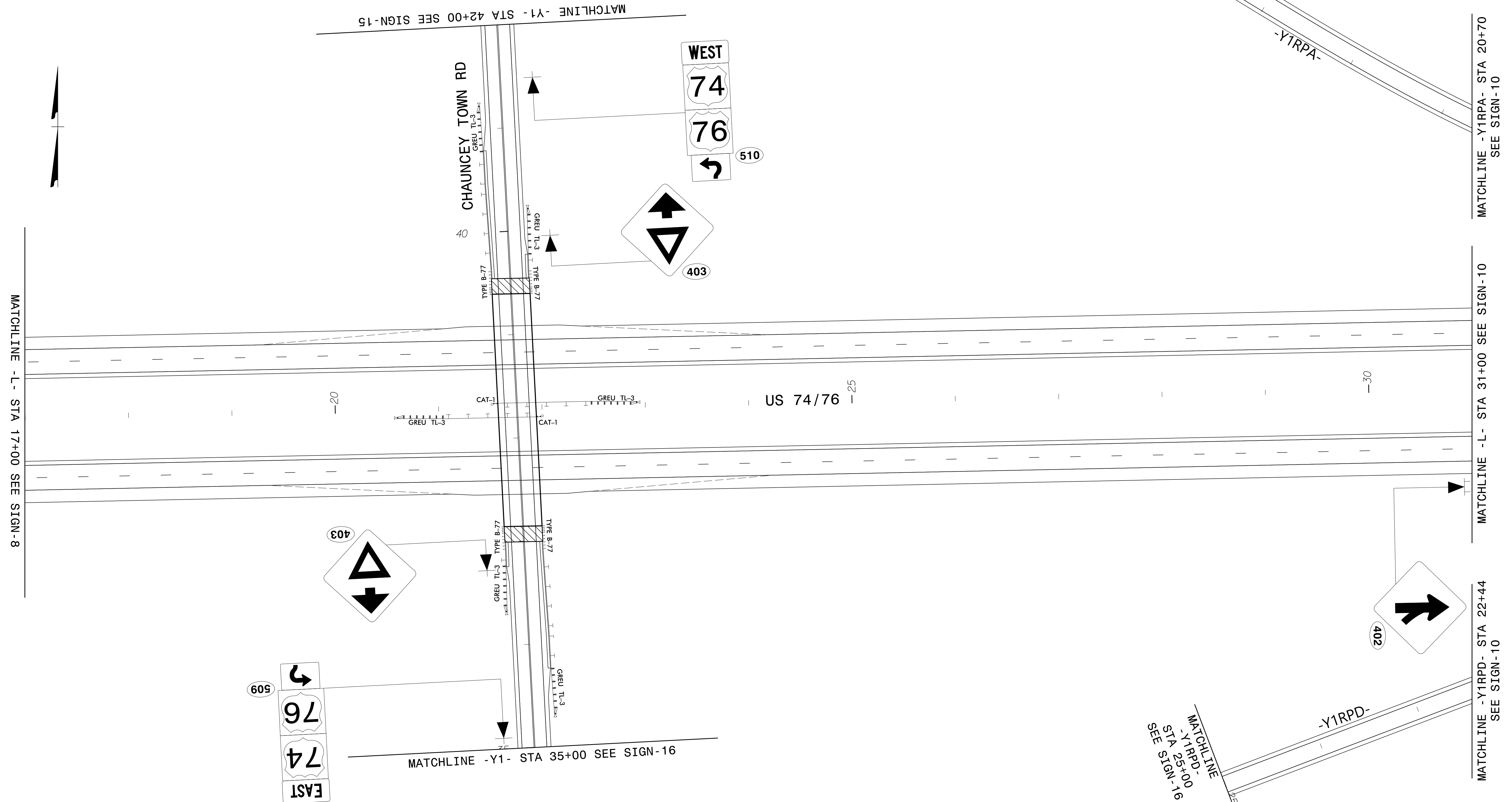

4/14/2022
 G:\50406565_Calyx_R5819_R5820\Traffic\Signing\CADD\Signing Layout\ Plans\R-5819 R-5820_Sgn_SGN_9.dgn
 User:COL85144

APPROVED: _____ DATE: _____ SEAL			<p style="text-align: center;">PROPOSED SIGNING DETAIL SHEET</p>
<p>DOCUMENT NOT CONSIDERED FINAL UNLESS ALL SIGNATURES COMPLETED</p>			

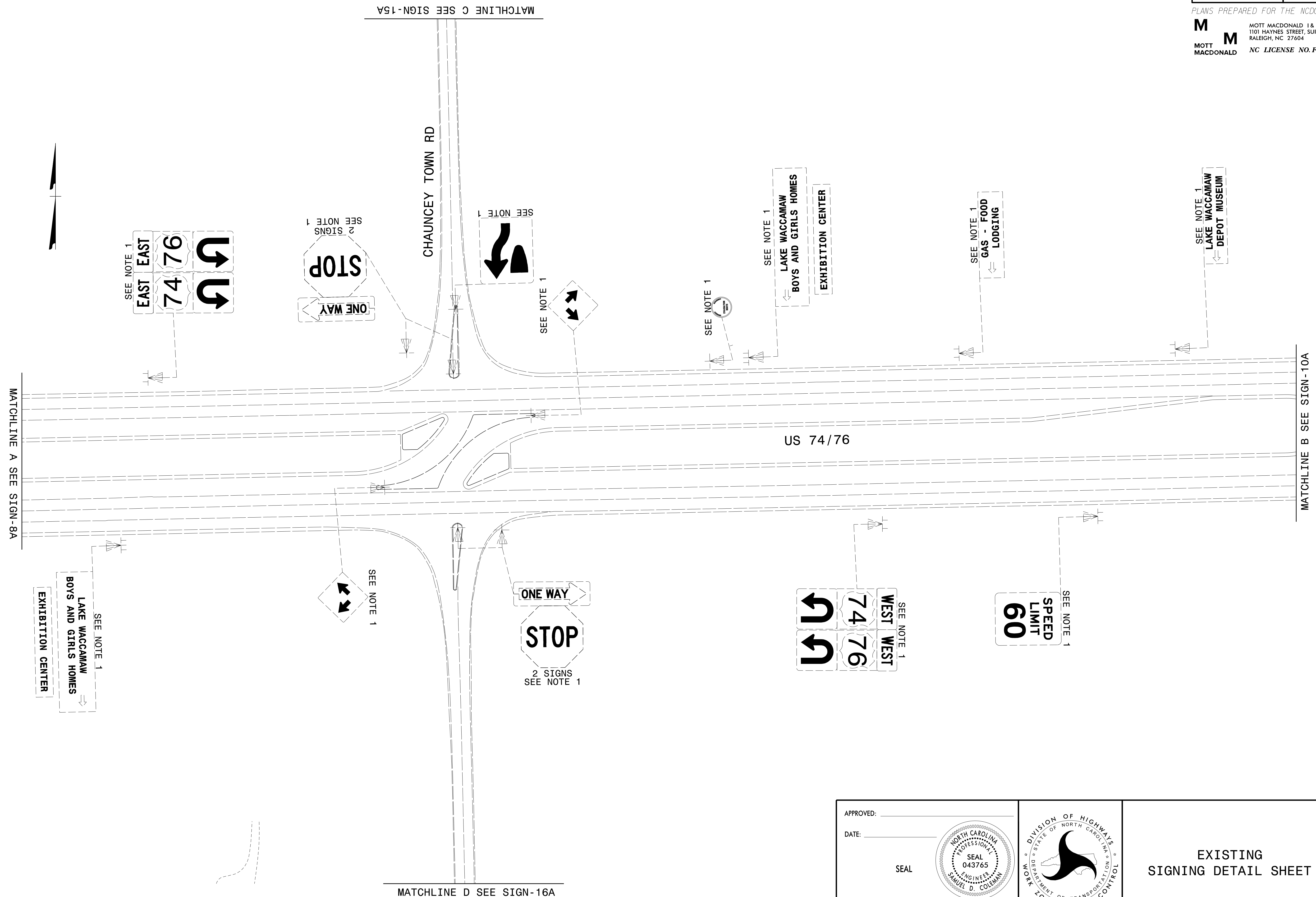

4/14/2022
 G:\50406565_Calyx_R5819_R5820\Tr\affic\Signing\CA00\Signing Layout Plans\R-5819_R-5820_Sgn_SGN_9a.dgn
 User:COL85144

APPROVED: _____ DATE: _____ SEAL			<p style="text-align: center;">EXISTING SIGNING DETAIL SHEET</p>
<p style="text-align: center;">DOCUMENT NOT CONSIDERED FINAL UNLESS ALL SIGNATURES COMPLETED</p>			

PLANS PREPARED FOR THE NCDOT BY:

M MOTT MACDONALD I & E, LLC
 1101 HAYNES STREET, SUITE 101
 RALEIGH, NC 27604
M MOTT MACDONALD NC LICENSE NO. F-0669

MATCHLINE -Y1RPA- STA 20+70 SEE SIGN-9
 MATCHLINE -L- STA 31+00 SEE SIGN-9
 MATCHLINE -Y1RPD- STA 22+44 SEE SIGN-9

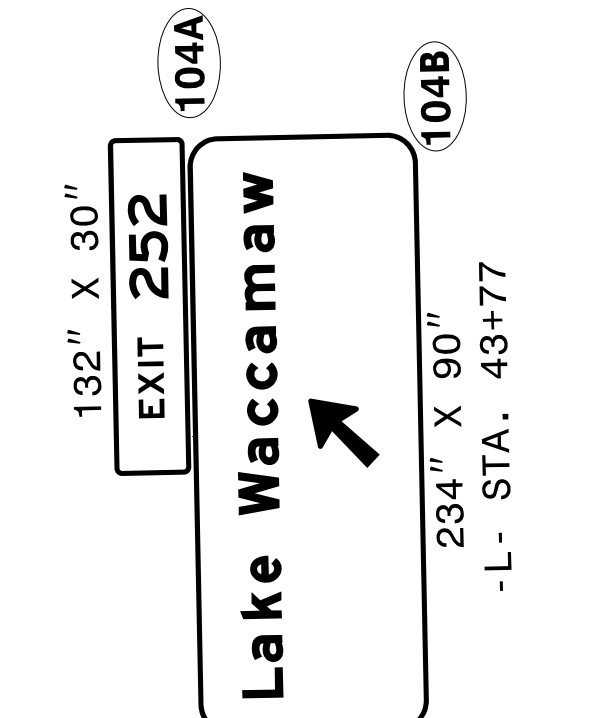
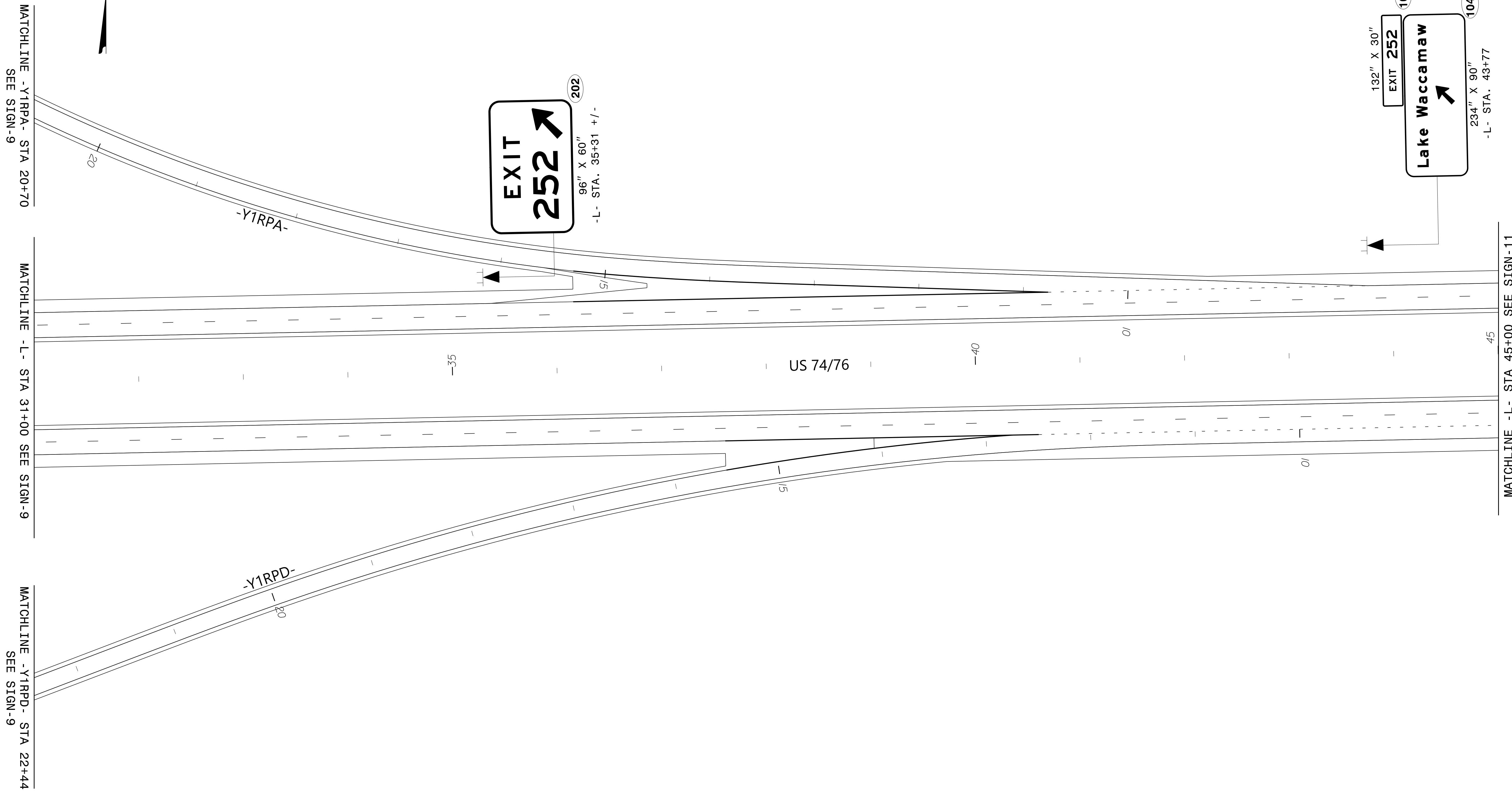
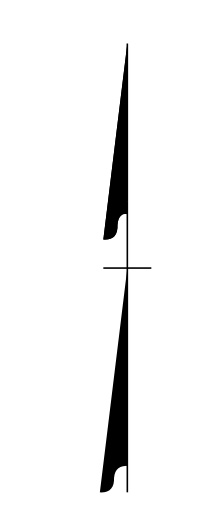

4/14/2022
 G:\501406565_Calyx_R5819_R5820\Traffic\Signing\CADD\Signing Layout Plans\R-5819 R-5820_Sgn_SGN10.dgn
 User:COL85144

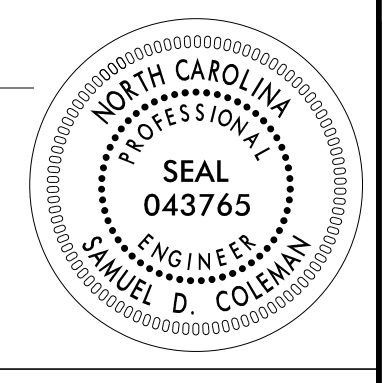
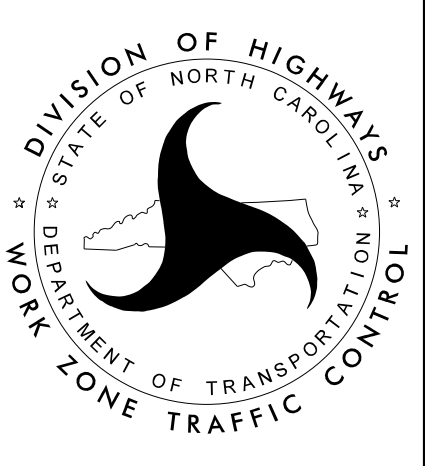
APPROVED: _____ DATE: _____ SEAL 		<p>PROPOSED SIGNING DETAIL SHEET</p>
<p>DOCUMENT NOT CONSIDERED FINAL UNLESS ALL SIGNATURES COMPLETED</p>		

PLANS PREPARED FOR THE NCDOT BY:

M MOTT MACDONALD I & E, LLC
 1101 HAYNES STREET, SUITE 101
 RALEIGH, NC 27604
M MOTT MACDONALD NC LICENSE NO. F-0669

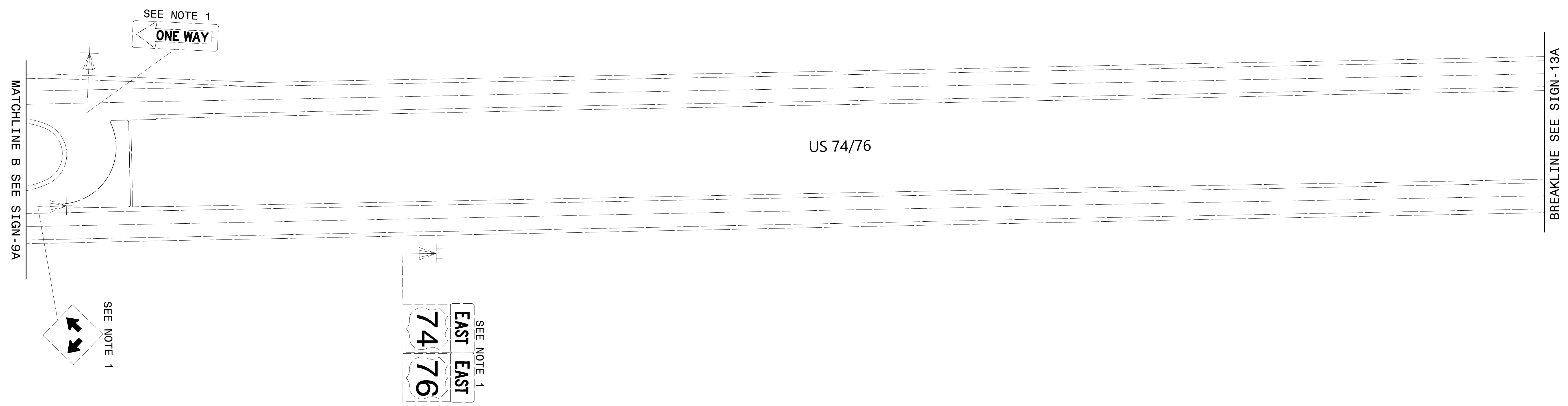

4/14/2022
 G:\50406565_Calyx_R5819_R5820\Tr-offic\Signing\CADD\Signing Layout Plans\R-5819_R-5820_Sgn_SGN_10a.dgn
 User:COL85144

APPROVED: _____ DATE: _____ SEAL		 EXISTING SIGNING DETAIL SHEET
<p style="text-align: center;">DOCUMENT NOT CONSIDERED FINAL UNLESS ALL SIGNATURES COMPLETED</p>		



PROJ. REFERENCE NO.	SHEET NO.
R-5819 R-5820	SIGN-11

PLANS PREPARED FOR THE NCDOT BY:

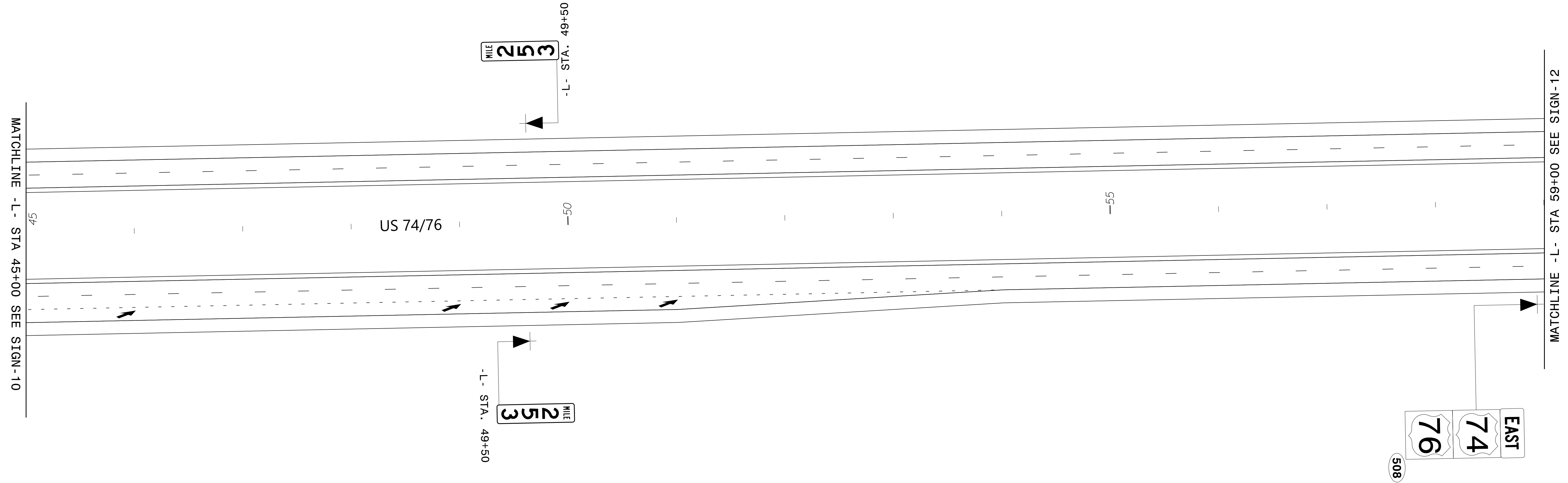
M MOTT MACDONALD I & E, LLC
 1101 HAYNES STREET, SUITE 101
 RALEIGH, NC 27604
M MOTT MACDONALD NC LICENSE NO. F-0669

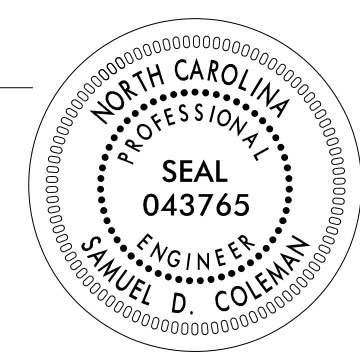

4/14/2022
 G:\50406565_Calyx_R5819_R5820\Tr-offic\Signing\CADD\Signing Layout Plans\R-5819 R-5820_Sgn_SGN.dgn
 User:COL85144

APPROVED: _____ DATE: _____ SEAL 		<p>PROPOSED SIGNING DETAIL SHEET</p>
<p>DOCUMENT NOT CONSIDERED FINAL UNLESS ALL SIGNATURES COMPLETED</p>		

PROJ. REFERENCE NO.	SHEET NO.
R-5819 R-5820	SIGN-12

PLANS PREPARED FOR THE NCDOT BY:

M MOTT MACDONALD I & E, LLC
1101 HAYNES STREET, SUITE 101
RALEIGH, NC 27604
M MOTT MACDONALD NC LICENSE NO. F-0669



MATCHLINE -L- STA 59+00 SEE SIGN-11

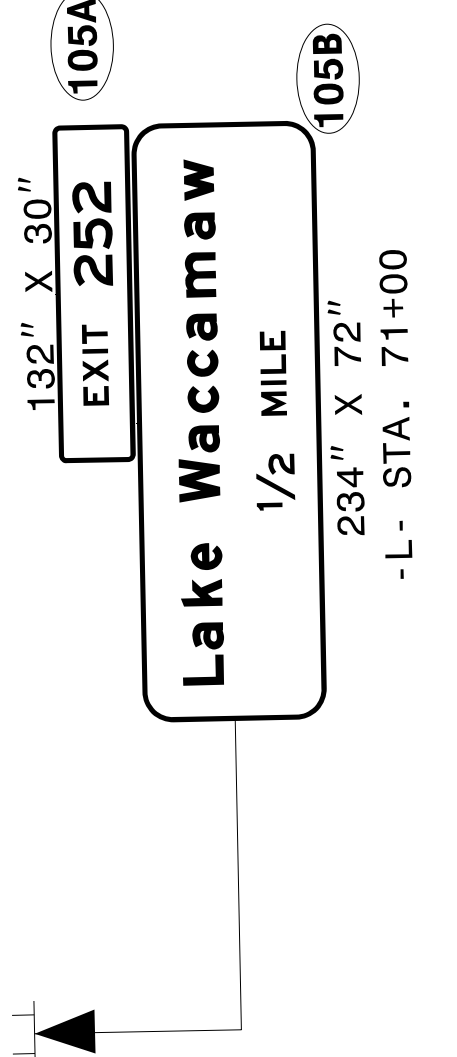
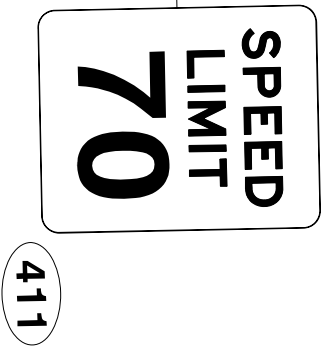
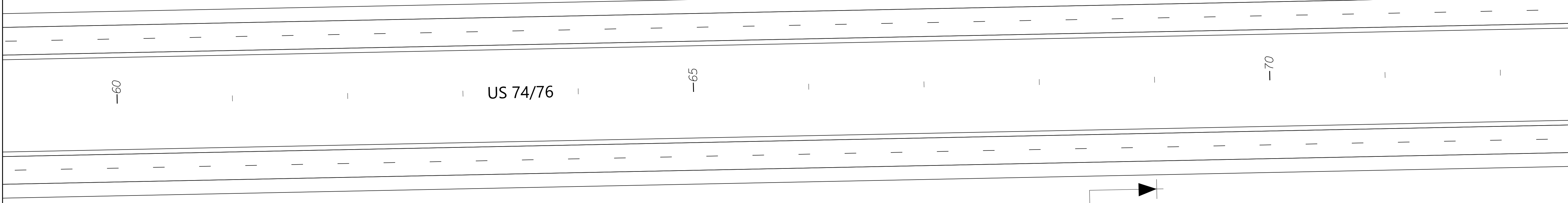

MATCHLINE -L- STA 72+59 SEE SIGN-13

4/14/2022
G:\50406565_Calyx_R5819_R5820\Tr-afftc\Signing\CAADD\Signing Layout Plans\R-5819 R-5820_Sgn_SGN.L2.dgn
User:COL85144

APPROVED: _____
DATE: _____

SEAL

**DOCUMENT NOT CONSIDERED FINAL
UNLESS ALL SIGNATURES COMPLETED**

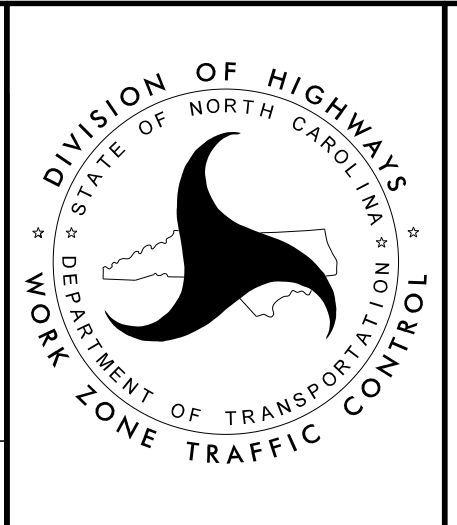

**PROPOSED
SIGNING DETAIL SHEET**

PROJ. REFERENCE NO.	SHEET NO.
R-5819 R-5820	SIGN-13

PLANS PREPARED FOR THE NCDOT BY:

M MOTT MACDONALD I & E, LLC
 1101 HAYNES STREET, SUITE 101
 RALEIGH, NC 27604
M MOTT MACDONALD NC LICENSE NO. F-0669

NO SIGNS THIS SHEET

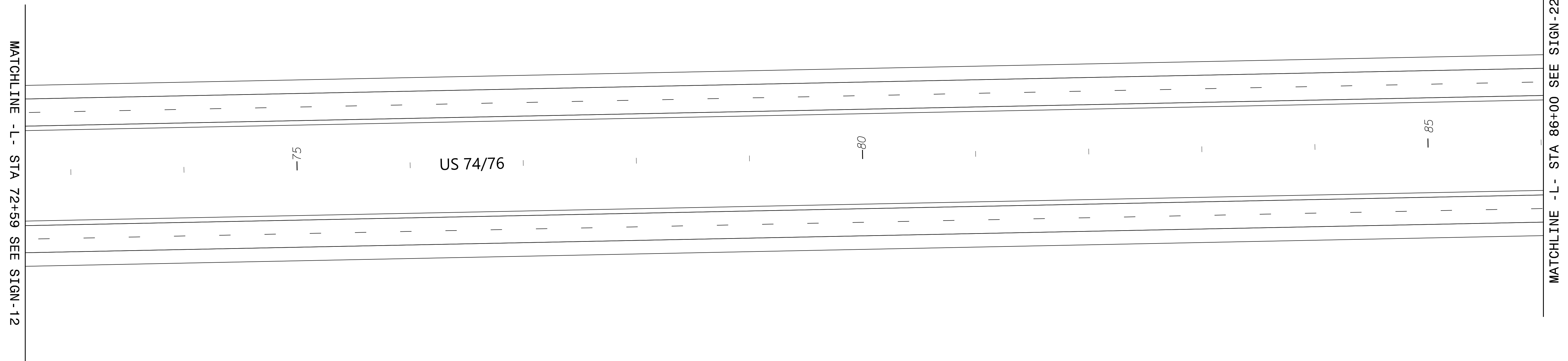
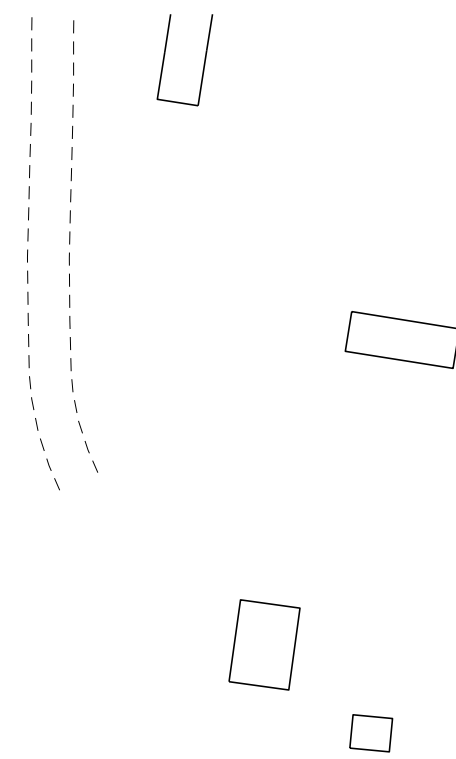
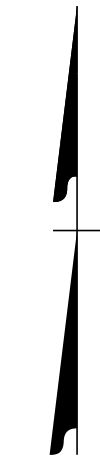

4/14/2022
 G:\50406565_Calyx_R5819_R5820\Tr-offic\Signing\CADD\Signing Layout Plans\R-5819 R-5820_Sgn_SGN_13.dgn
 User:COL85144

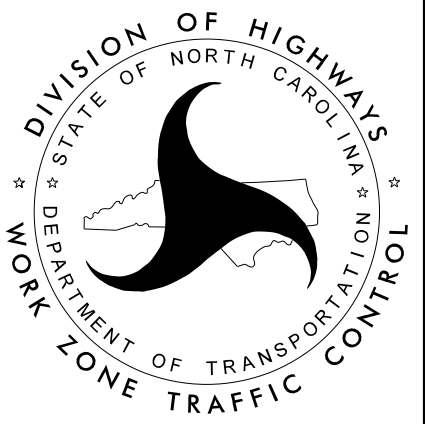

APPROVED: _____ DATE: _____ SEAL 		<p style="text-align: center;">PROPOSED SIGNING DETAIL SHEET</p>
<p style="text-align: center;">DOCUMENT NOT CONSIDERED FINAL UNLESS ALL SIGNATURES COMPLETED</p>		

PLANS PREPARED FOR THE NCDOT BY:

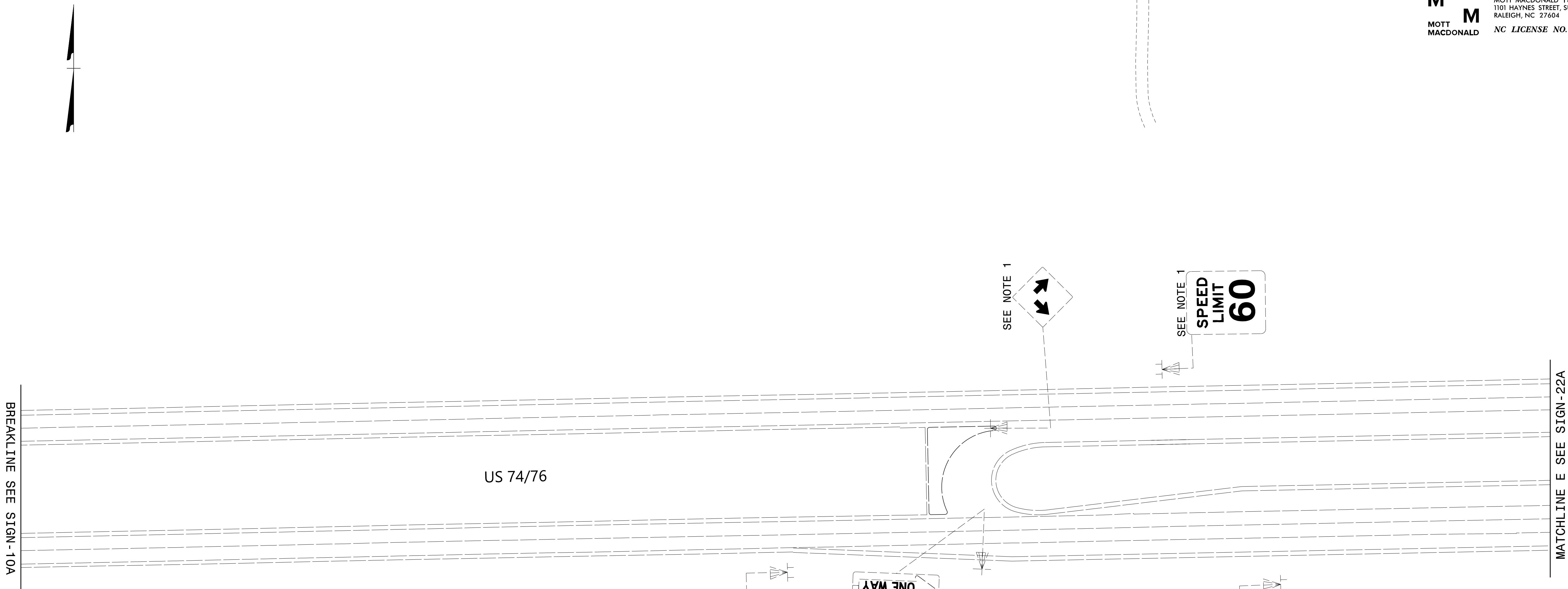
M MOTT MACDONALD I & E, LLC
 1101 HAYNES STREET, SUITE 101
 RALEIGH, NC 27604
M MOTT MACDONALD NC LICENSE NO. F-0669

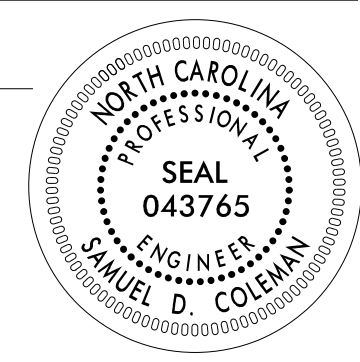

4/14/2022
 G:\50406565_Calyx_R5819_R5820\Tr-offic\Signing\CADD\Signing Layout Plans\R-5819_R-5820_Sgn_SGN_13a.dgn
 User:COL85144

APPROVED: _____ DATE: _____ SEAL 		<p>EXISTING SIGNING DETAIL SHEET</p>
<p>DOCUMENT NOT CONSIDERED FINAL UNLESS ALL SIGNATURES COMPLETED</p>		

PROJ. REFERENCE NO.	SHEET NO.
R-5819 R-5820	SIGN-14

PLANS PREPARED FOR THE NCDOT BY:

M MOTT MACDONALD I & E, LLC
1101 HAYNES STREET, SUITE 101
RALEIGH, NC 27604
M MOTT MACDONALD NC LICENSE NO. F-0669

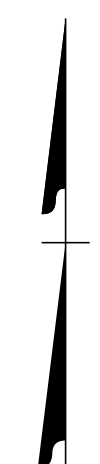
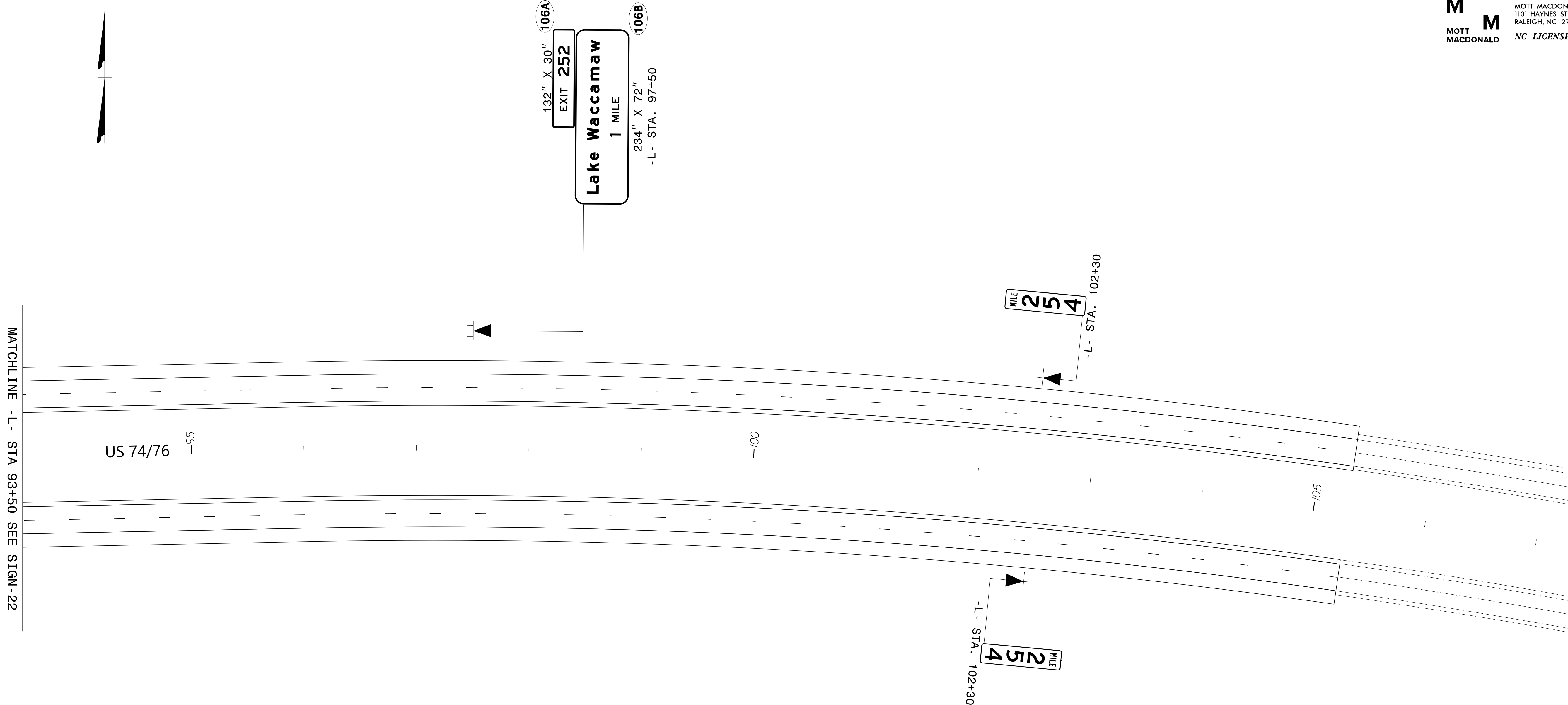

4/14/2022
G:\50406565_Calyx_R5819_R5820\Tr-offic\Signing\CADD\Signing_Layout_Plans\R-5819_R-5820_Sgn_SGN_14.dgn
User:COL85144

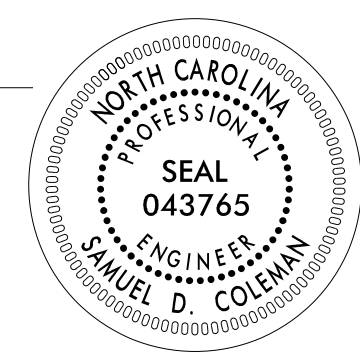
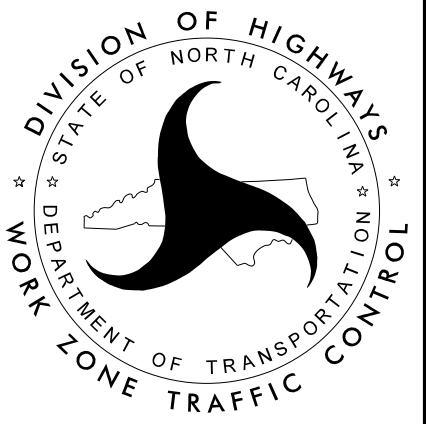
APPROVED: _____ DATE: _____ SEAL 		<p>PROPOSED SIGNING DETAIL SHEET</p>
<p>DOCUMENT NOT CONSIDERED FINAL UNLESS ALL SIGNATURES COMPLETED</p>		

PLANS PREPARED FOR THE NCDOT BY:

M MOTT MACDONALD I & E, LLC
 1101 HAYNES STREET, SUITE 101
 RALEIGH, NC 27604
M MOTT MACDONALD NC LICENSE NO. F-0669

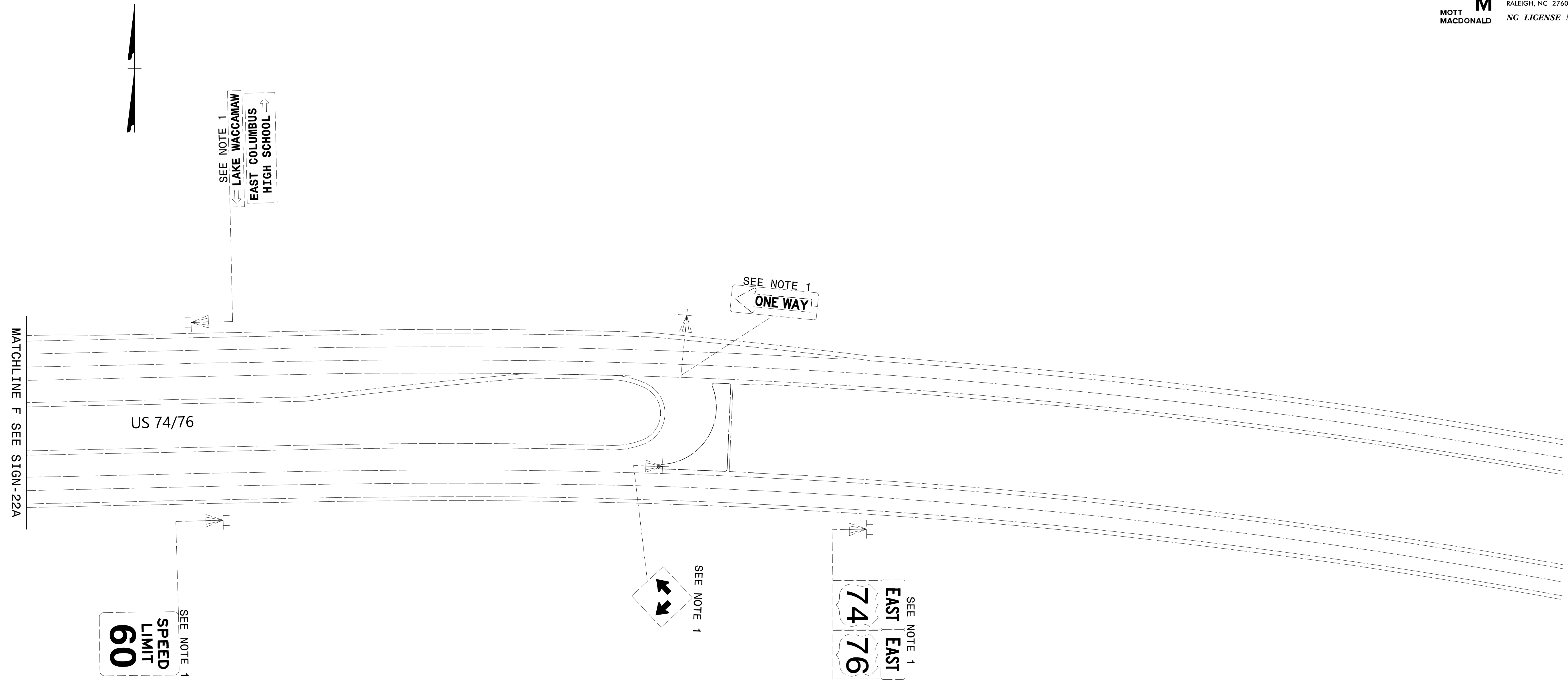

4/14/2022
 G:\501406565_Calyx_R5819_R5820\Tr-offic\Signing\CADD\Signing Layout\ Plans\R-5819 R-5820_Sgn_SGN_14a.dgn
 User:COL85144

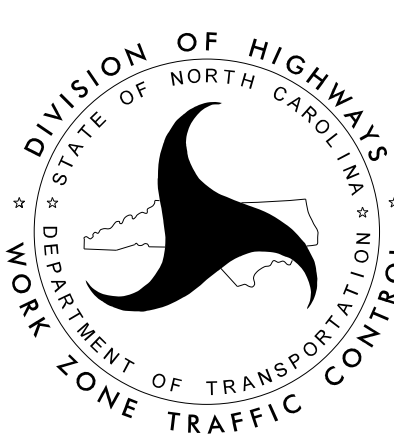
APPROVED: _____ DATE: _____ SEAL 		<p>EXISTING SIGNING DETAIL SHEET</p>
<p>DOCUMENT NOT CONSIDERED FINAL UNLESS ALL SIGNATURES COMPLETED</p>		

PLANS PREPARED FOR THE NCDOT BY:

M MOTT MACDONALD I & E, LLC
 1101 HAYNES STREET, SUITE 101
 RALEIGH, NC 27604
M MOTT MACDONALD NC LICENSE NO. F-0669

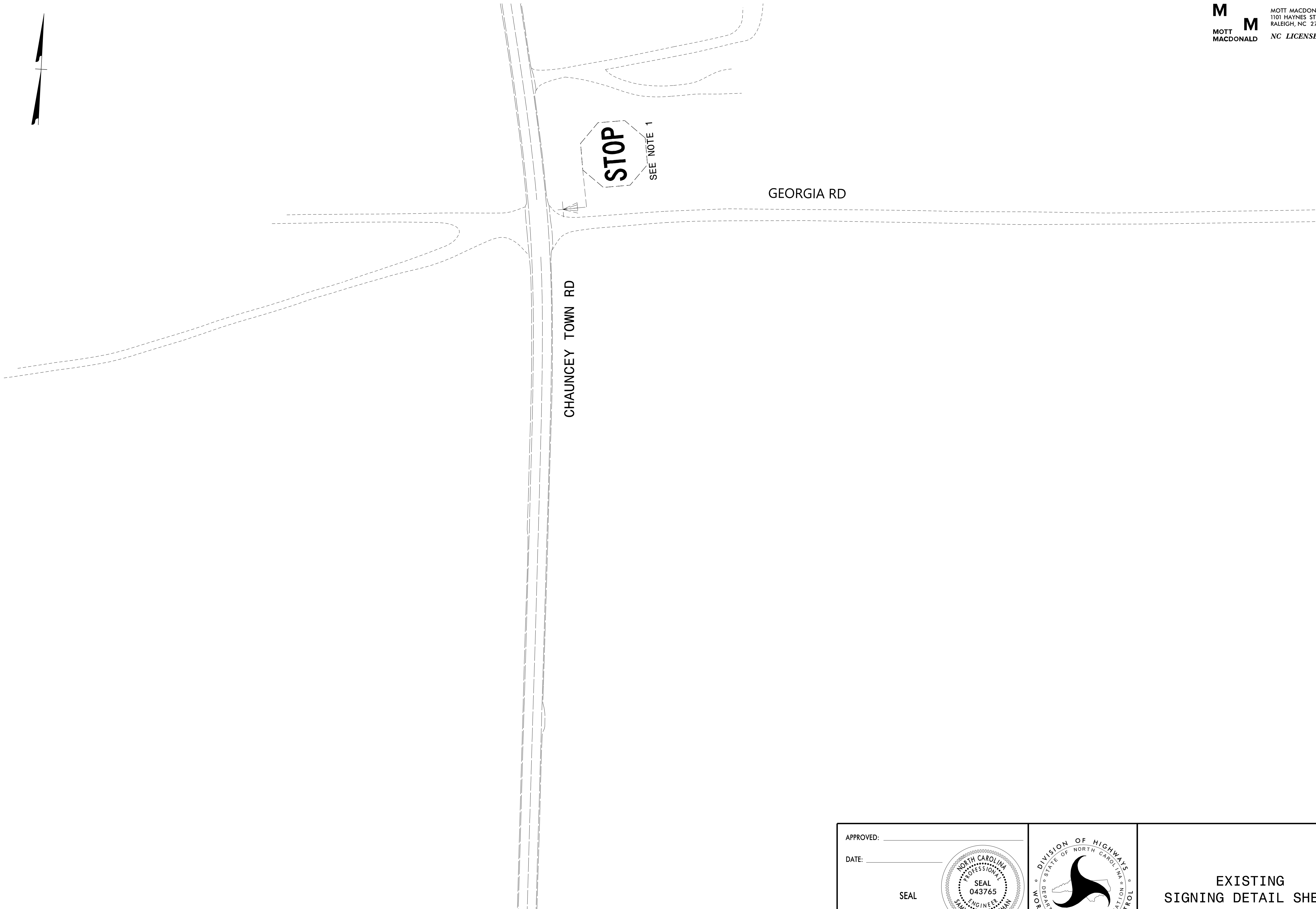

MATCHLINE C SEE SIGN-9A

4/14/2022
 G:\50406565_Calyx_R5819_R5820\Tr-afftc\Signing\CADD\Signing Layout Plans\R-5819 R-5820_Sgn_SGN15a.dgn
 User:COL85144

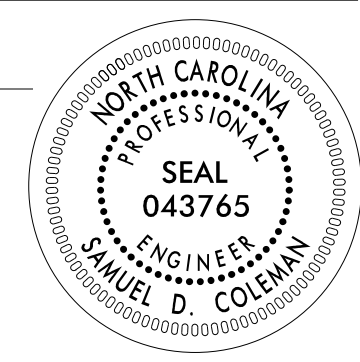
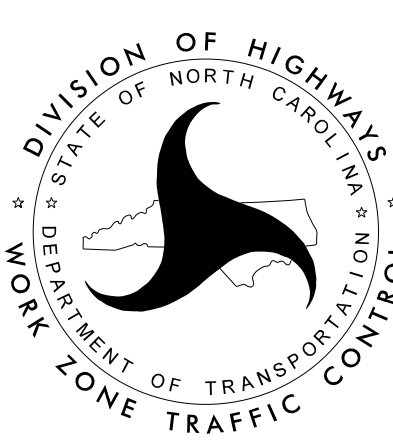
APPROVED: _____ DATE: _____ SEAL 		<p>EXISTING SIGNING DETAIL SHEET</p>
<p>DOCUMENT NOT CONSIDERED FINAL UNLESS ALL SIGNATURES COMPLETED</p>		

BREAKLINE -Y1RPC- SEE SIGN-8

MATCHLINE -Y1- STA 35+00 SEE SIGN-9

MATCHLINE -Y1RPD- STA 00+52 SEE SIGN-10

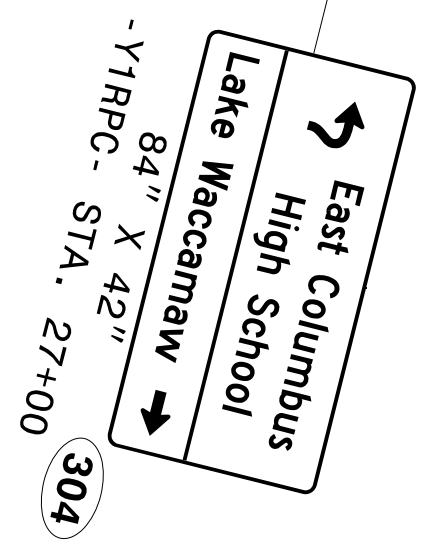
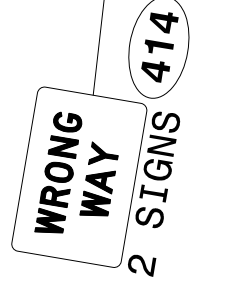
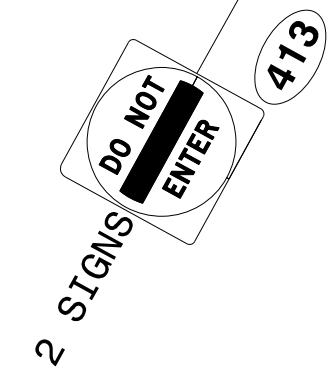
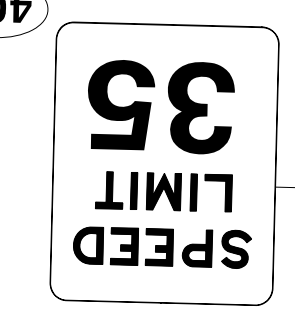
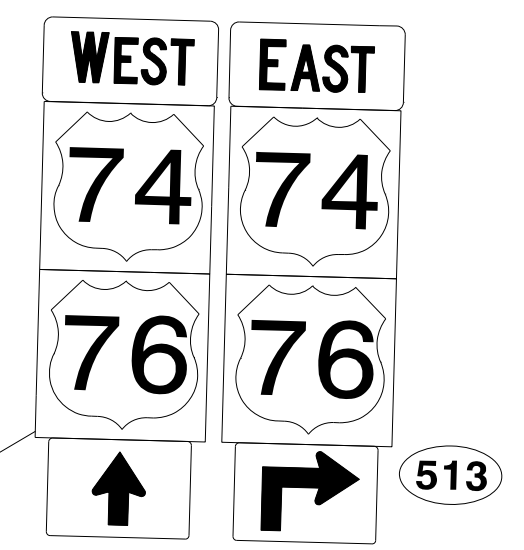
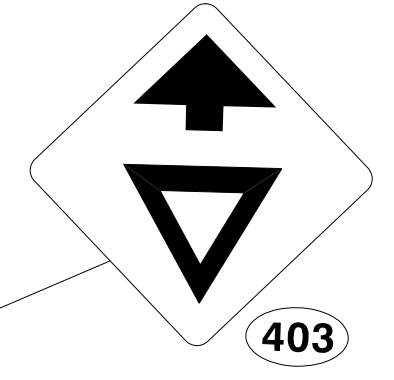
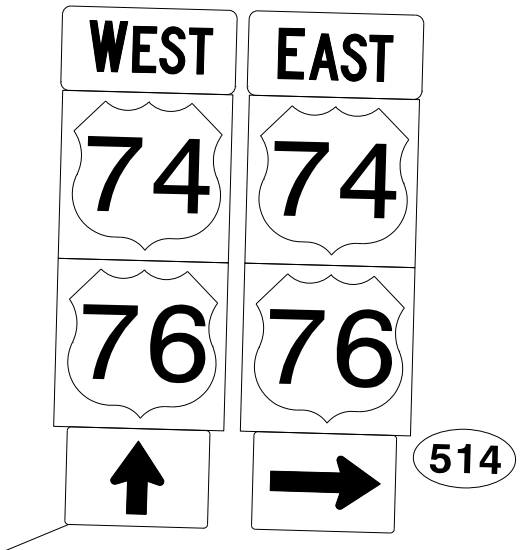
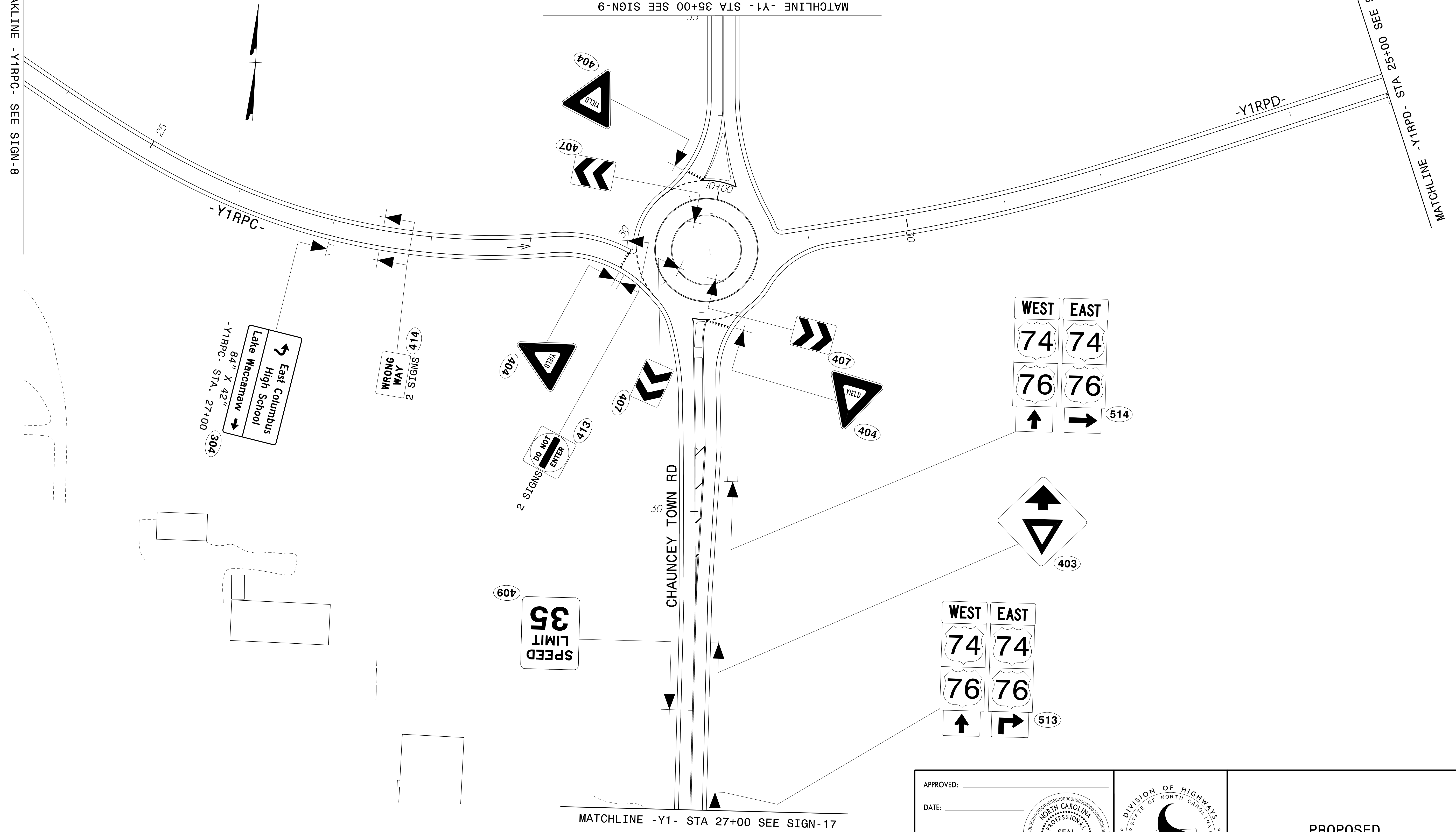

MATCHLINE -Y1- STA 27+00 SEE SIGN-17

APPROVED: _____

DATE: _____

SEAL

DOCUMENT NOT CONSIDERED FINAL UNLESS ALL SIGNATURES COMPLETED

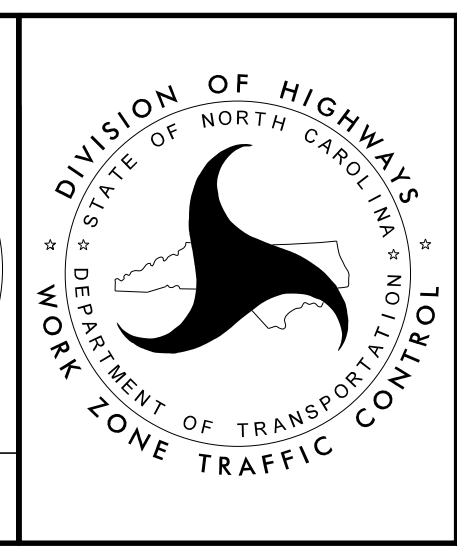

PROPOSED SIGNING DETAIL SHEET

PLANS PREPARED FOR THE NCDOT BY:

M MOTT MACDONALD I & E, LLC
 1101 HAYNES STREET, SUITE 101
 RALEIGH, NC 27604
M MOTT MACDONALD NC LICENSE NO. F-0669



MATCHLINE D SEE SIGN-9A

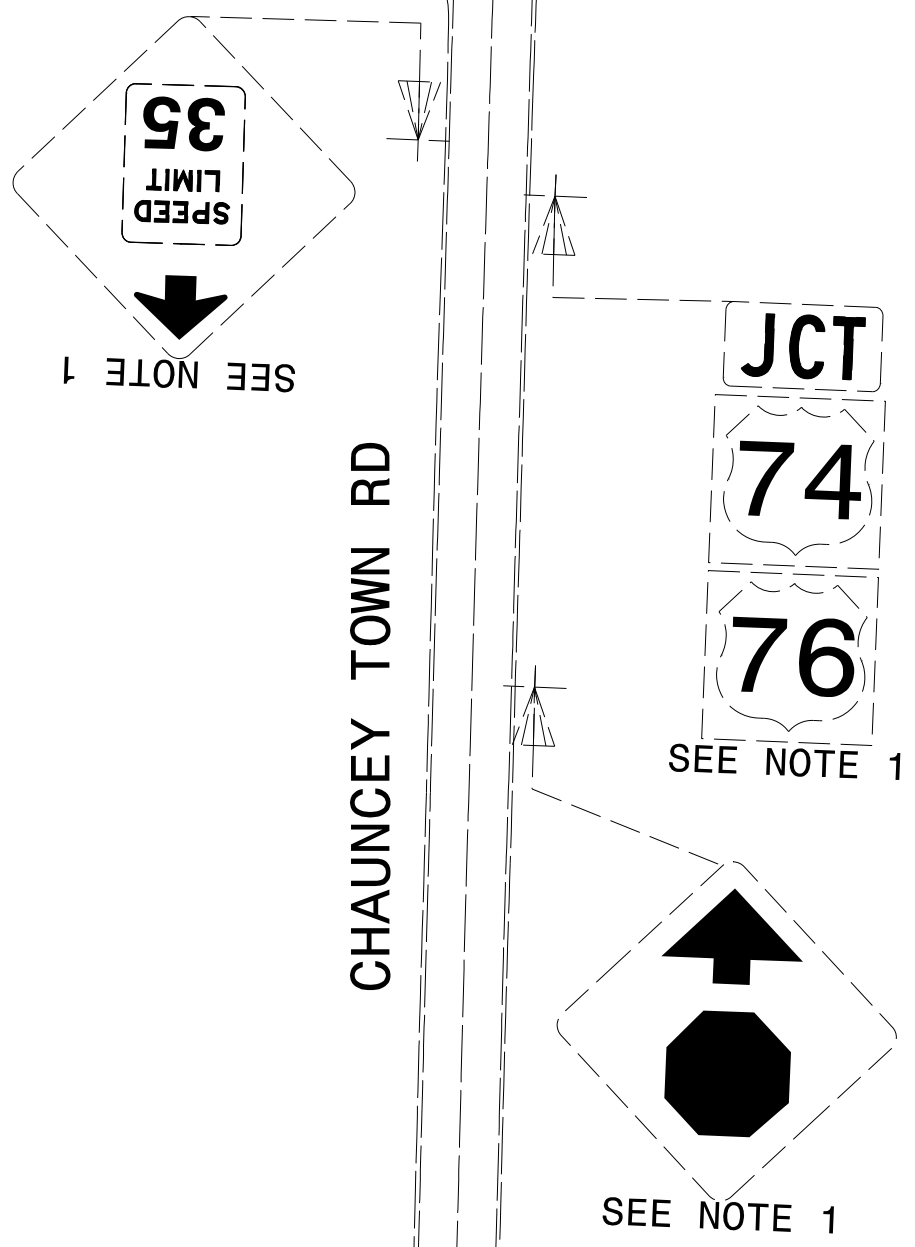

MATCHLINE G SEE SIGN-17A

4/14/2022
 G:\50406565_Calyx_R5819_R5820\Tr-afftc\Signing\CADD\Signing Layout Plans\R-5819_R-5820_Sgn_Sgn_16a.dgn
 User:COL85144

APPROVED: _____ DATE: _____ SEAL			EXISTING SIGNING DETAIL SHEET
DOCUMENT NOT CONSIDERED FINAL UNLESS ALL SIGNATURES COMPLETED			

PROJ. REFERENCE NO.	SHEET NO.
R-5819 R-5820	SIGN-17

PLANS PREPARED FOR THE NCDOT BY:

M MOTT MACDONALD I & E, LLC
 1101 HAYNES STREET, SUITE 101
 RALEIGH, NC 27604
M MOTT MACDONALD NC LICENSE NO. F-0669

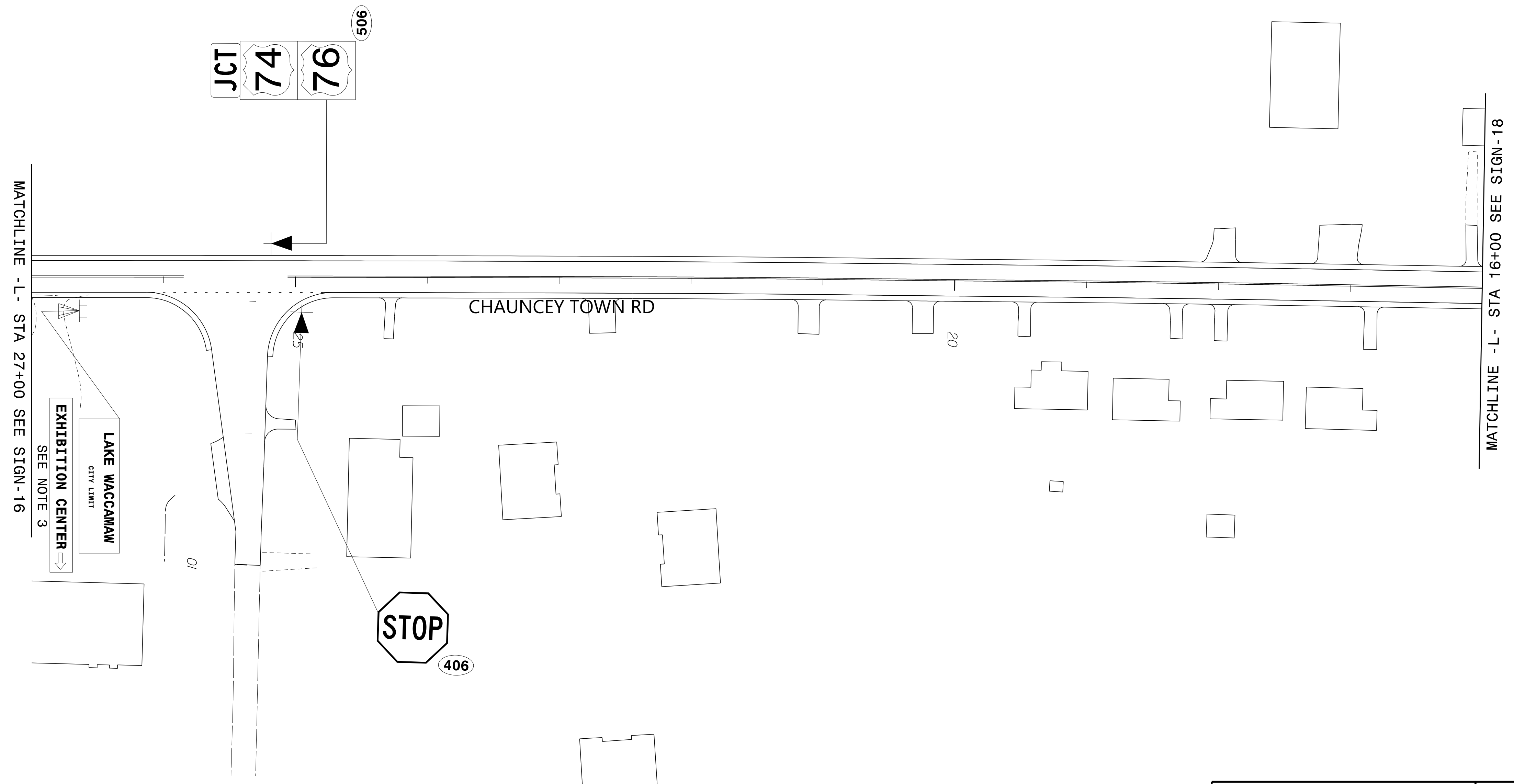
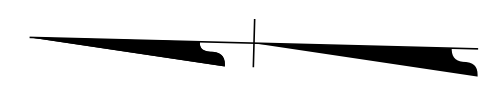

4/14/2022
 G:\50406565_Calyx_R5819_R5820\Tr\affic\Signing\CAADD\Signing_Layout_Plans\R-5819_R-5820_Sgn_SGN_17.dgn
 User:COL85144

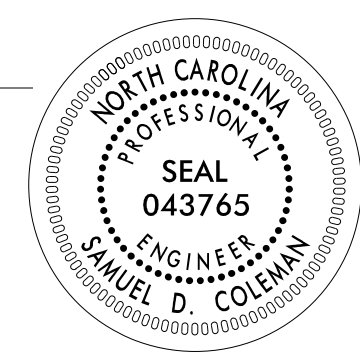
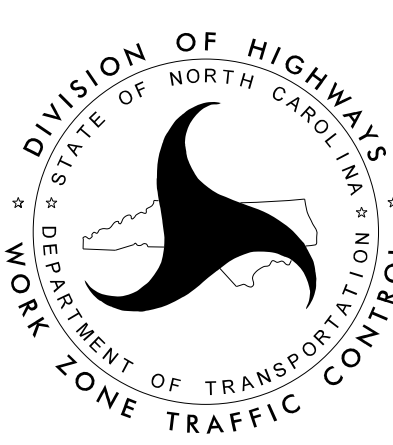

APPROVED: _____ DATE: _____ SEAL 		<p>PROPOSED SIGNING DETAIL SHEET</p>
<p>DOCUMENT NOT CONSIDERED FINAL UNLESS ALL SIGNATURES COMPLETED</p>		

PLANS PREPARED FOR THE NCDOT BY:

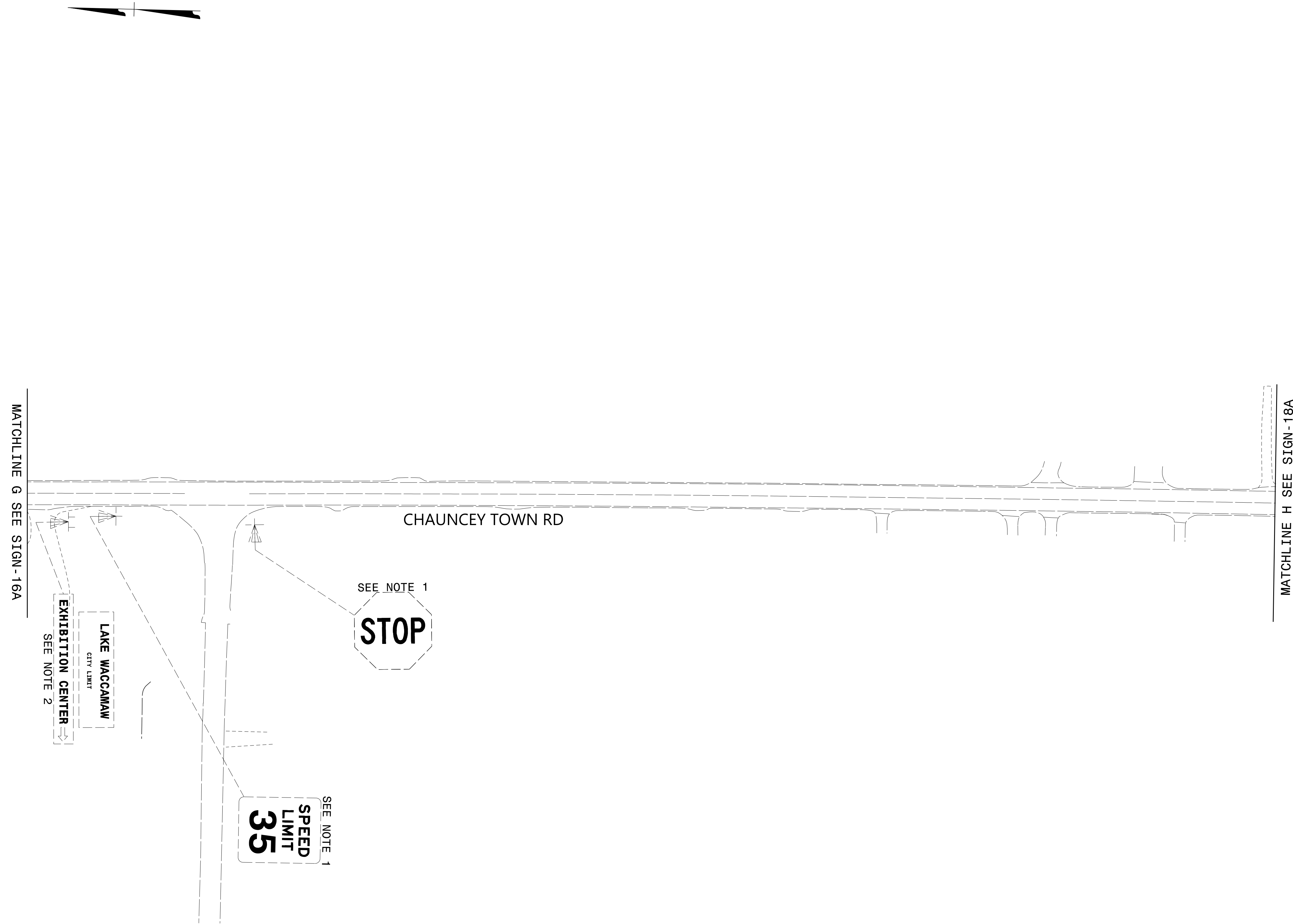
M MOTT MACDONALD I & E, LLC
 1101 HAYNES STREET, SUITE 101
 RALEIGH, NC 27604
M MOTT MACDONALD NC LICENSE NO. F-0669

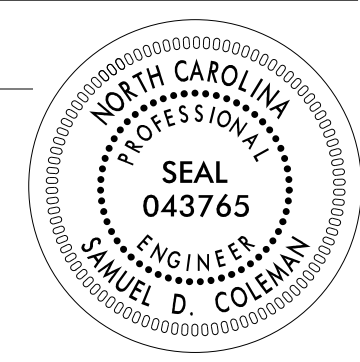

4/14/2022
 G:\501406565_Calyx_R5819_R5820\Tr-offic\Signing\CAADD\Signing_Layout_Plans\R-5819_R-5820_Sgn_Sgn_17a.dgn
 User:COL85144

APPROVED: _____ DATE: _____ SEAL 		<p style="text-align: center;">EXISTING SIGNING DETAIL SHEET</p>
<p>DOCUMENT NOT CONSIDERED FINAL UNLESS ALL SIGNATURES COMPLETED</p>		

END CONSTRUCTION
 -Y3- POC STA 21+23

END CONSTRUCTION
 -Y1A- POT STA 11+97

BEGIN CONSTRUCTION
 -Y3- POC STA 13+40

MATCHLINE -Y1- STA 16+00 SEE SIGN-17

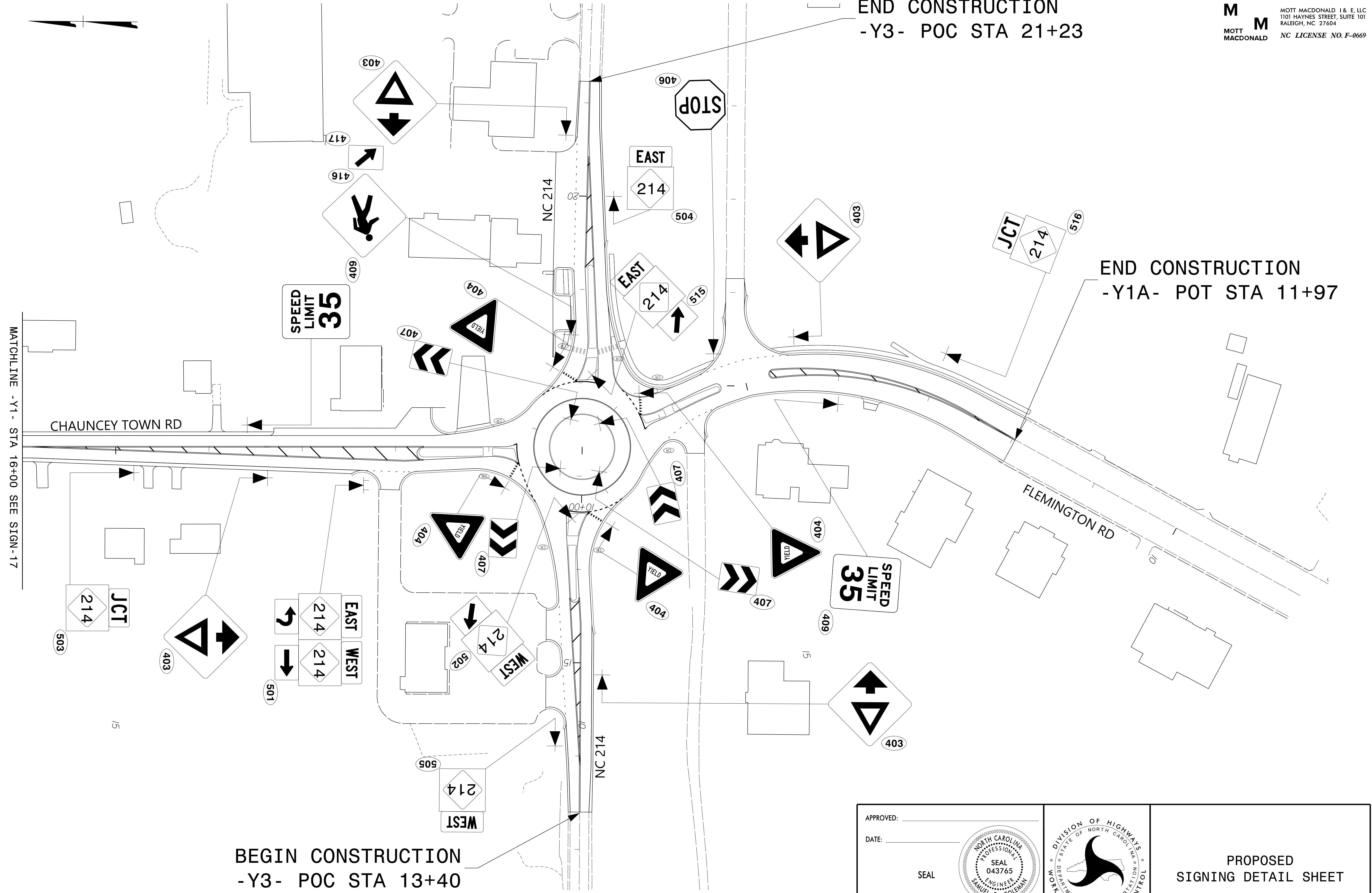

APPROVED: _____			<p>PROPOSED SIGNING DETAIL SHEET</p>
DATE: _____			

PLANS PREPARED FOR THE NCDOT BY:

M MOTT MACDONALD I & E, LLC
 1101 HAYNES STREET, SUITE 101
 RALEIGH, NC 27604
M MOTT MACDONALD NC LICENSE NO. F-0669

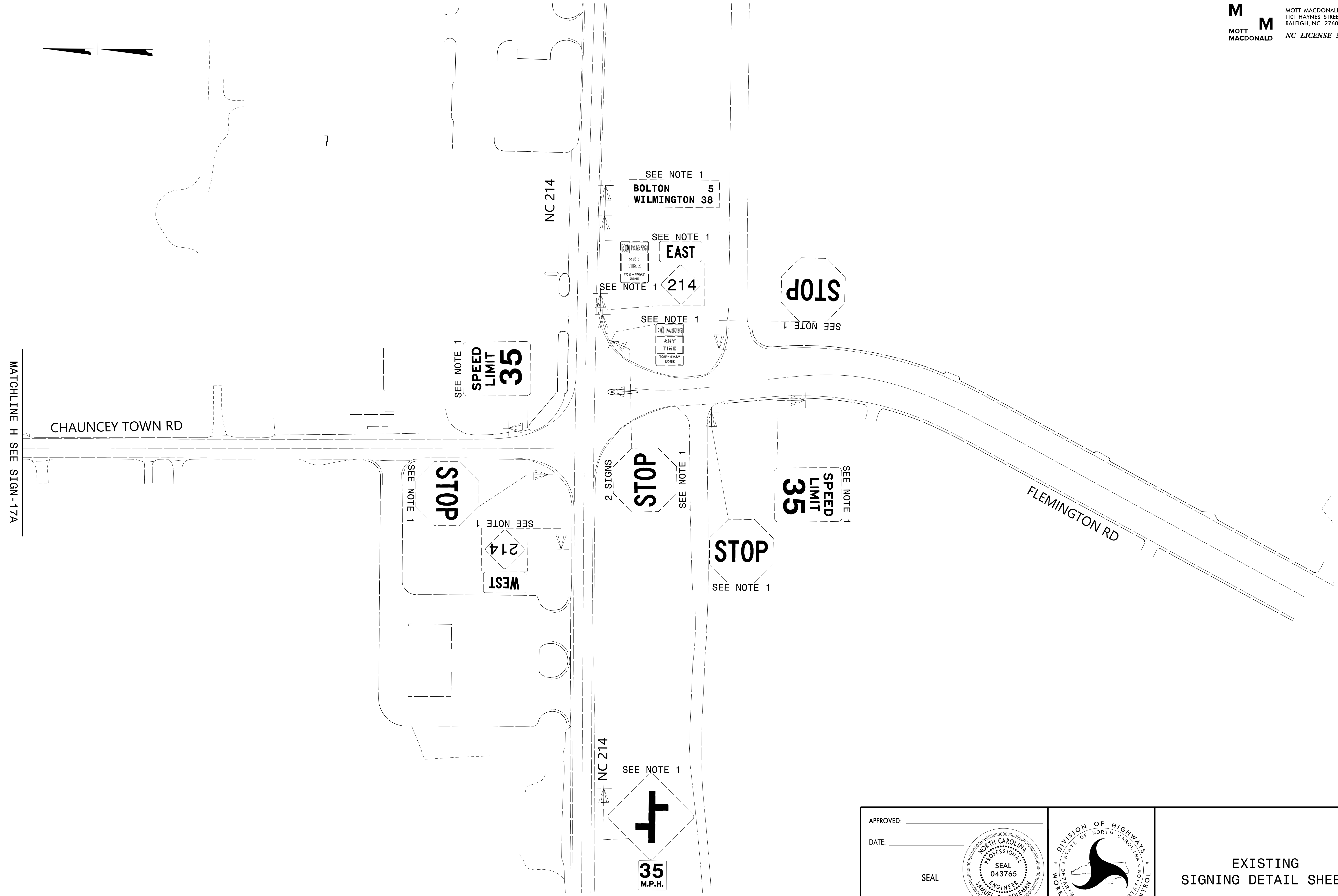

MATCHLINE H SEE SIGN-17A

4/14/2022
 G:\50406565_Calyx_R5819_R5820\Tr-offic\Signing\CADD\Signing Layout Plans\R-5819_R-5820_Sgn_18a.dgn
 User:COL85144

APPROVED: _____ DATE: _____ SEAL			EXISTING SIGNING DETAIL SHEET
<p>DOCUMENT NOT CONSIDERED FINAL UNLESS ALL SIGNATURES COMPLETED</p>			

PROJ. REFERENCE NO.	SHEET NO.
R-5819 R-5820	SIGN-19

PLANS PREPARED FOR THE NCDOT BY:

M MOTT MACDONALD I & E, LLC
 1101 HAYNES STREET, SUITE 101
 RALEIGH, NC 27604
M MOTT MACDONALD NC LICENSE NO. F-0669

NO SIGN THIS SHEET



BREAKLINE -Y7- SEE SIGN-15

MATCHLINE -Y7- STA 77+00 SEE SIGN-20

4/14/2022
 G:\50406565_Calyx_R5819_R5820\Traffic\Signing\CADD\Signing_Layout_Plans\R-5819_R-5820_Sgn_SGN_19.dgn
 User:COL85144

APPROVED: _____ DATE: _____ SEAL		 PROPOSED SIGNING DETAIL SHEET
<p>DOCUMENT NOT CONSIDERED FINAL UNLESS ALL SIGNATURES COMPLETED</p>		

PLANS PREPARED FOR THE NCDOT BY:

M MOTT MACDONALD I & E, LLC
 1101 HAYNES STREET, SUITE 101
 RALEIGH, NC 27604
M MOTT MACDONALD NC LICENSE NO. F-0669

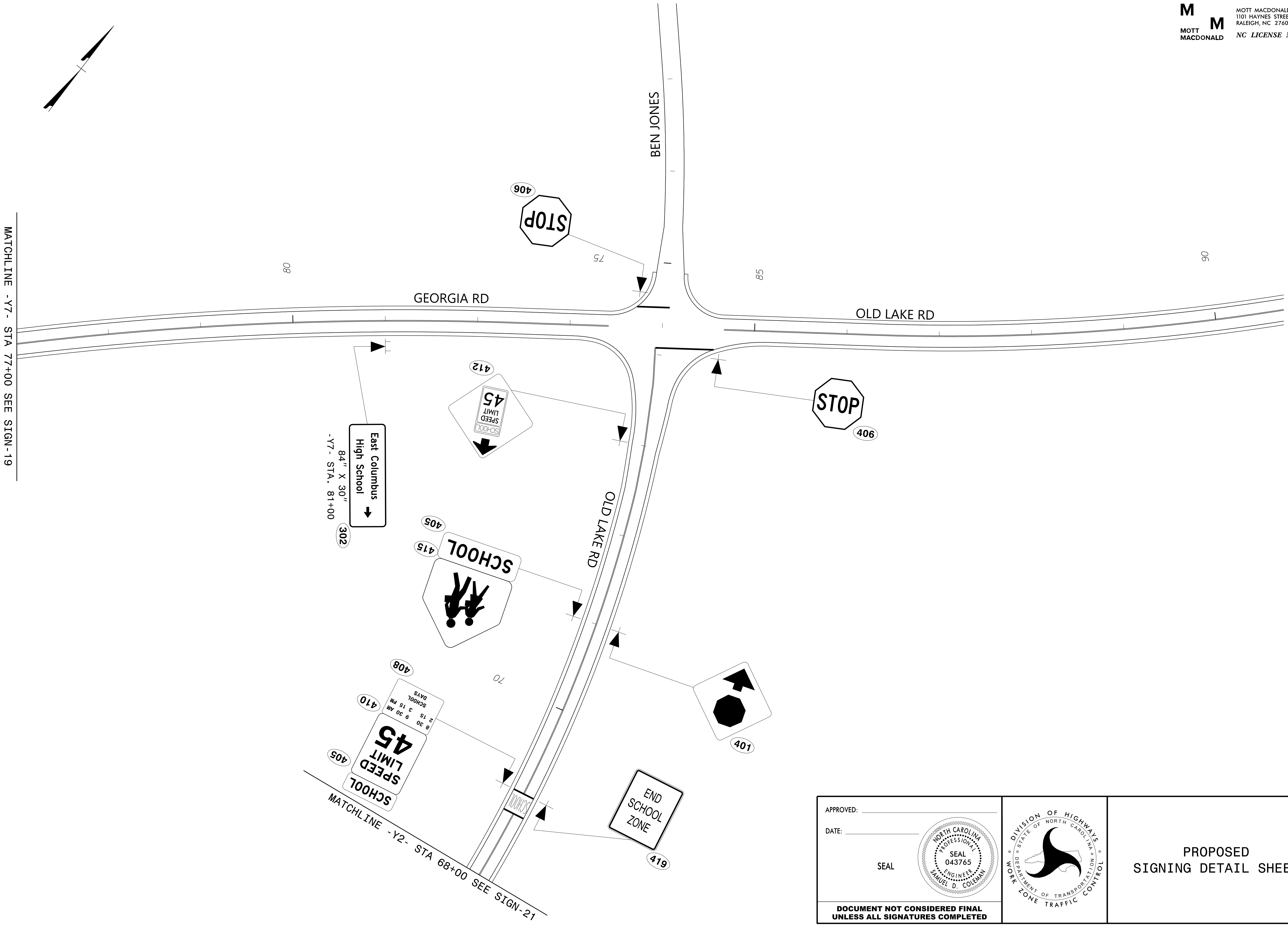

MATCHLINE -Y7- STA 77+00 SEE SIGN-19

MATCHLINE -Y2- STA 68+00 SEE SIGN-21

APPROVED: _____
 DATE: _____
 SEAL

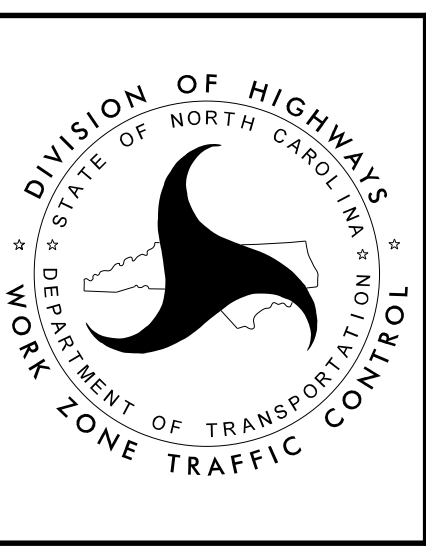
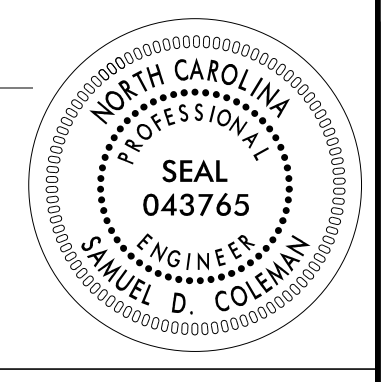

PROPOSED
 SIGNING DETAIL SHEET

PLANS PREPARED FOR THE NCDOT BY:

M MOTT MACDONALD I & E, LLC
 1101 HAYNES STREET, SUITE 101
 RALEIGH, NC 27604
M MOTT MACDONALD NC LICENSE NO. F-0669

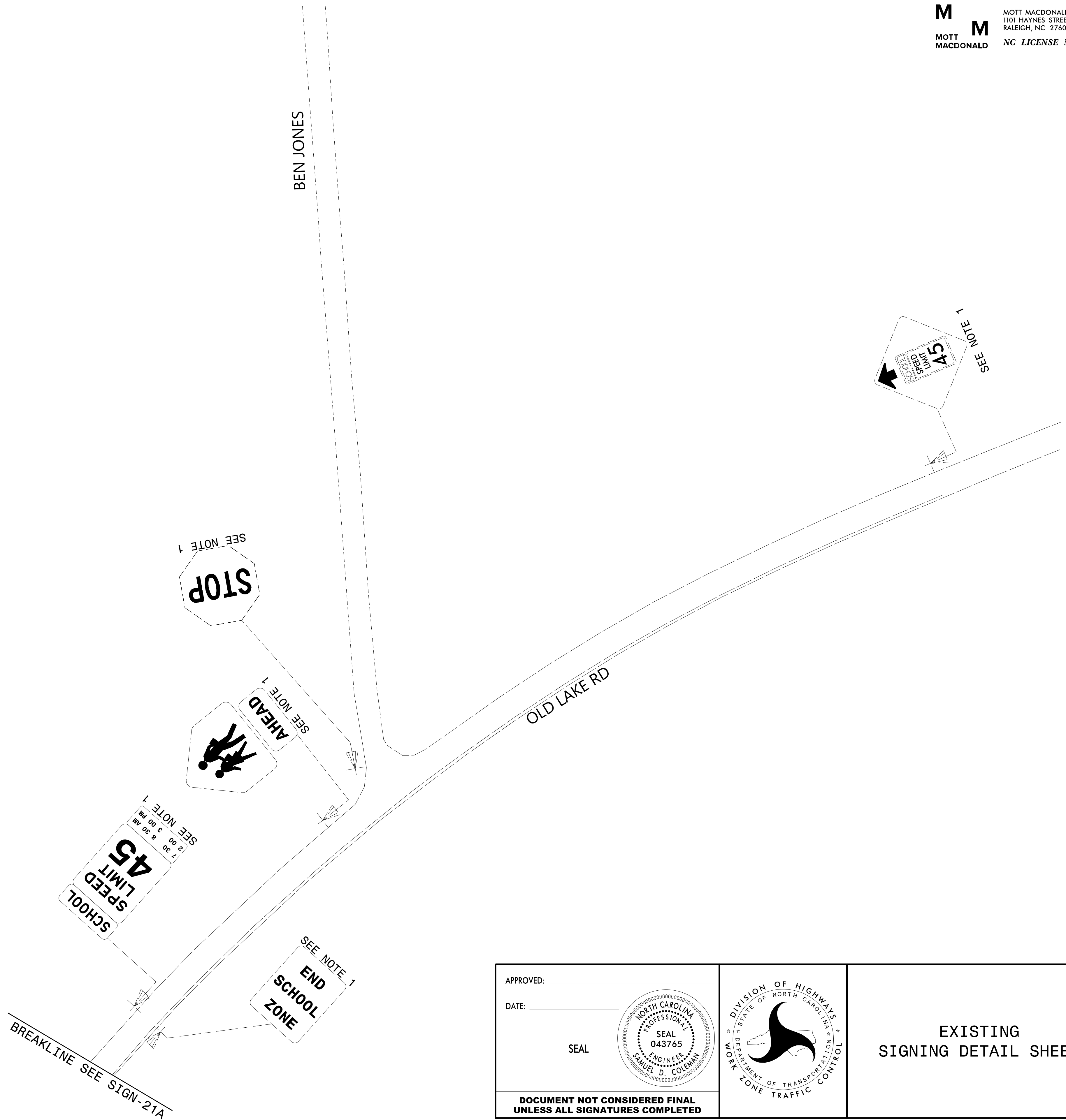
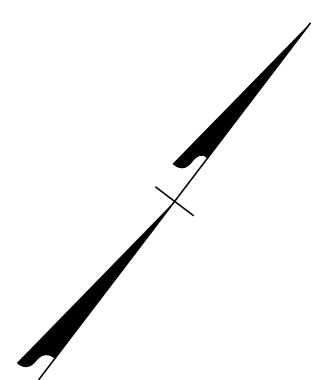

4/14/2022
 G:\50406565_Calyx_R-5819_R-5820\Traffic\Signing\CADD\Signing Layout Plans\R-5819 R-5820_Sgn_SGN_20a.dgn
 User:COL85144

APPROVED: _____ DATE: _____ SEAL		 <p style="text-align: center;">EXISTING SIGNING DETAIL SHEET</p>
<p>DOCUMENT NOT CONSIDERED FINAL UNLESS ALL SIGNATURES COMPLETED</p>		

PROJ. REFERENCE NO.	SHEET NO.
R-5819 R-5820	SIGN-21

PLANS PREPARED FOR THE NCDOT BY:

M MOTT MACDONALD I & E, LLC
 1101 HAYNES STREET, SUITE 101
 RALEIGH, NC 27604
M MOTT MACDONALD NC LICENSE NO. F-0669

NO SIGNS THIS SHEET



MATCHLINE -Y2- STA 68+00 SEE SIGN-20

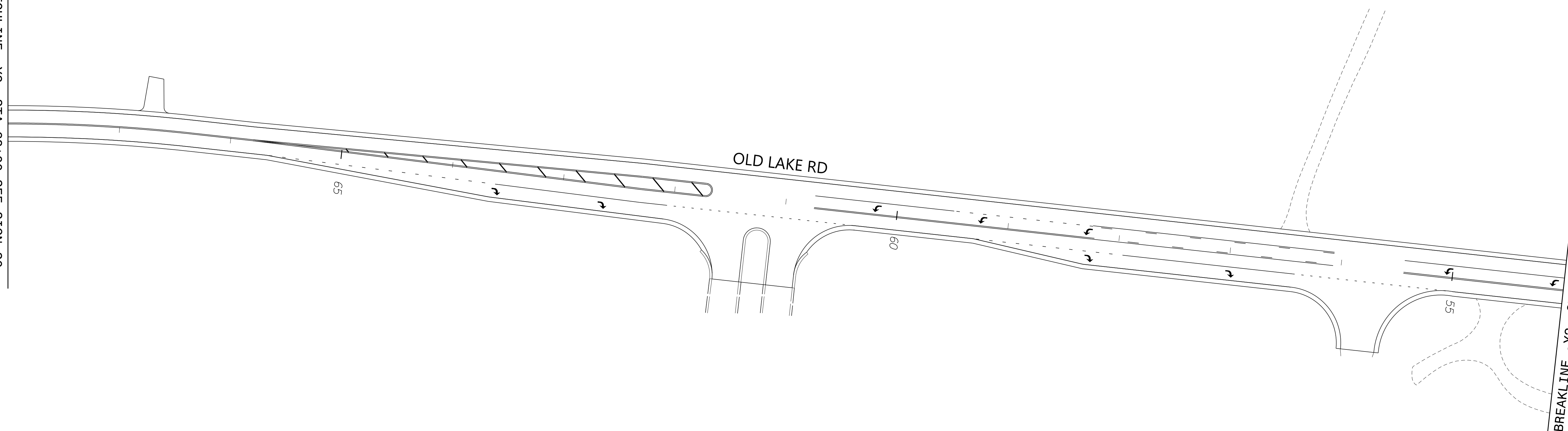

BREAKLINE -Y2- STA 54+00 SEE SIGN-22

4/14/2022
 G:\50406565_Calyx_R5819_R5820\Tr-office\Signing\CADD\Signing_Layout_Plans\R-5819_R-5820_Sgn_SGN_21.dgn
 User:COL85144

APPROVED: _____ DATE: _____ SEAL			<p style="text-align: center;">PROPOSED SIGNING DETAIL SHEET</p>
<p style="text-align: center;">DOCUMENT NOT CONSIDERED FINAL UNLESS ALL SIGNATURES COMPLETED</p>			

PROJ. REFERENCE NO.	SHEET NO.
R-5819 R-5820	SIGN-21A

PLANS PREPARED FOR THE NCDOT BY:

M MOTT MACDONALD I & E, LLC
 1101 HAYNES STREET, SUITE 101
 RALEIGH, NC 27604
M MOTT MACDONALD NC LICENSE NO. F-0669



BREAKLINE SEE SIGN-20A

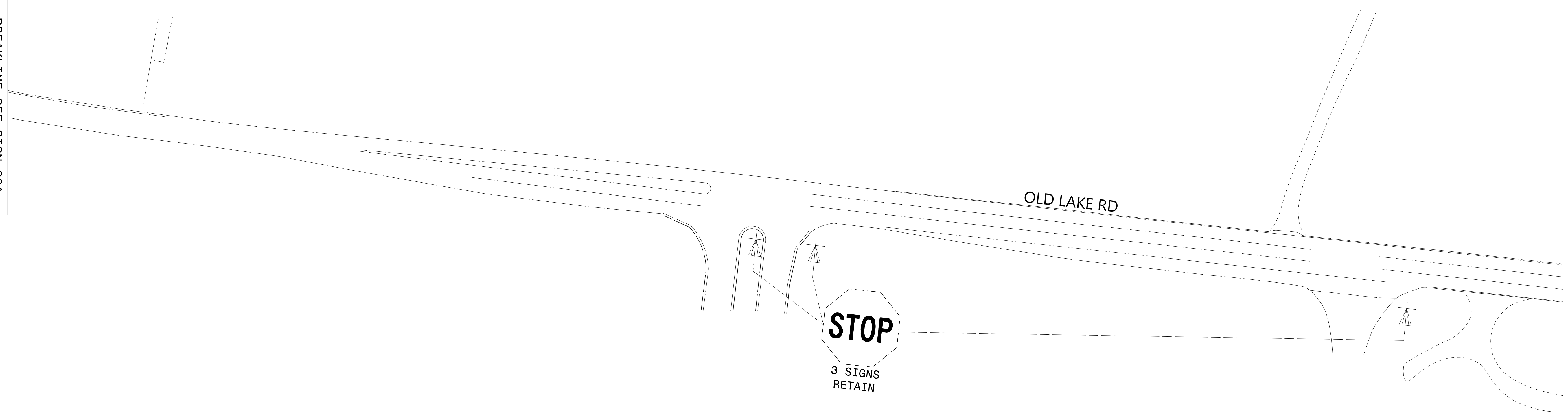

BREAKLINE SEE SIGN-22A

4/14/2022
 G:\50406565_Calyx_R5819_R5820\Tr-office\Signing\CADD\Signing_Layout_Plans\R-5819_R-5820_Sgn_SGN_21a.dgn
 User:COL85144

APPROVED: _____ DATE: _____ SEAL			<p>EXISTING SIGNING DETAIL SHEET</p>
<p>DOCUMENT NOT CONSIDERED FINAL UNLESS ALL SIGNATURES COMPLETED</p>			

PLANS PREPARED FOR THE NCDOT BY:

M MOTT MACDONALD I & E, LLC
 1101 HAYNES STREET, SUITE 101
 RALEIGH, NC 27604
M MOTT MACDONALD NC LICENSE NO. F-0669

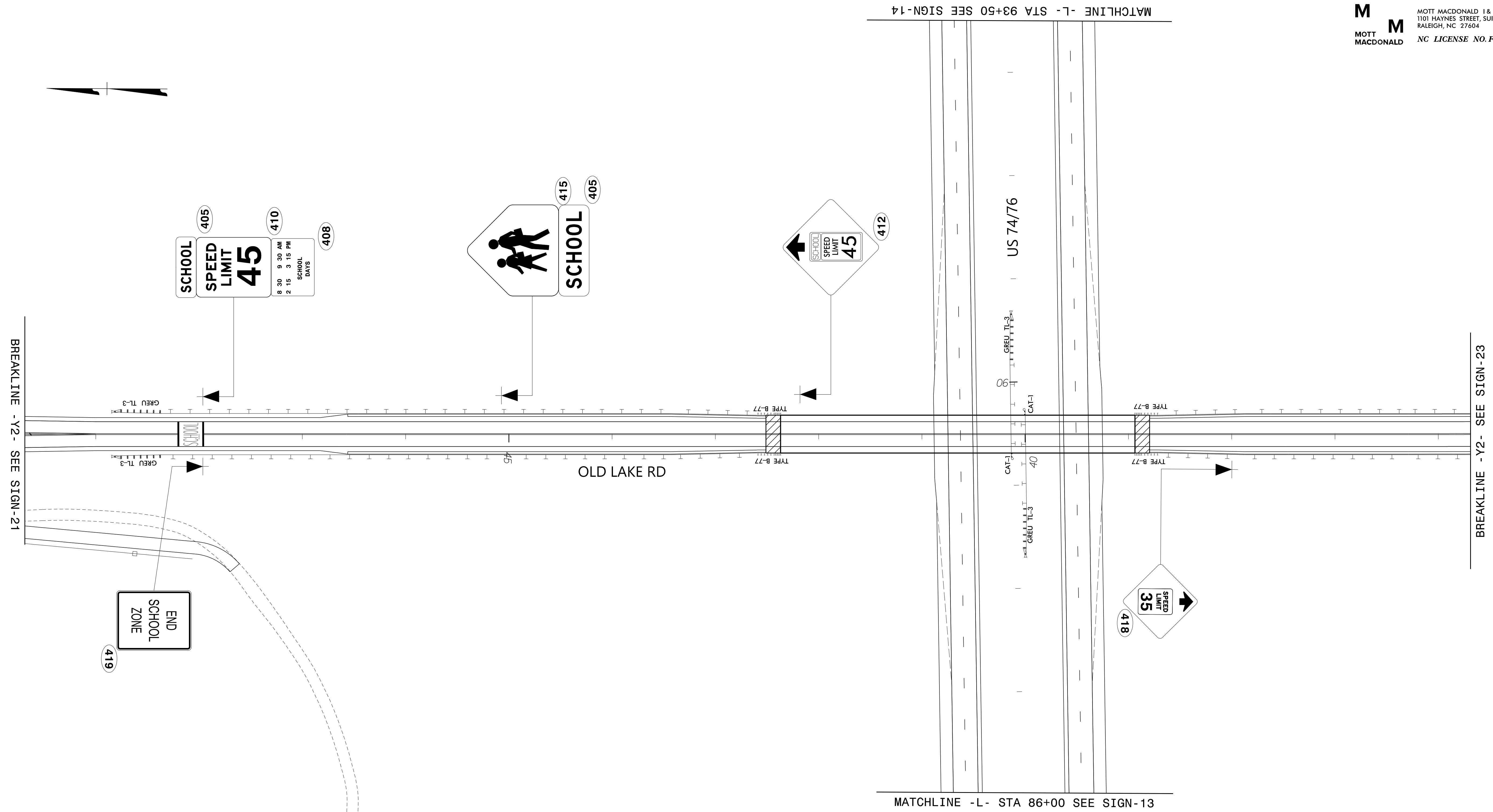

4/14/2022
 G:\50406565_Calyx_R5820\VR-5819_R-5820\Traffic\Signing\CADD\Signing Layout\ Plans\VR-5819 R-5820_Sgn_SGN.22.dgn
 User:COL85144

APPROVED: _____
 DATE: _____
 SEAL

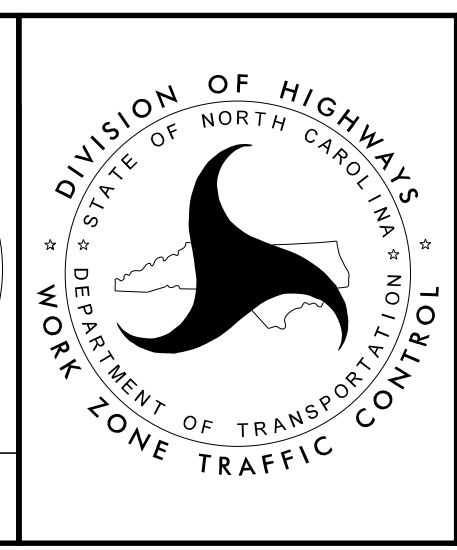
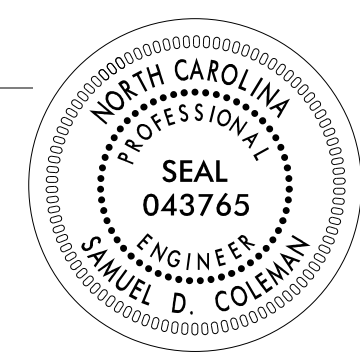

**PROPOSED
SIGNING DETAIL SHEET**



**DOCUMENT NOT CONSIDERED FINAL
UNLESS ALL SIGNATURES COMPLETED**

PLANS PREPARED FOR THE NCDOT BY:

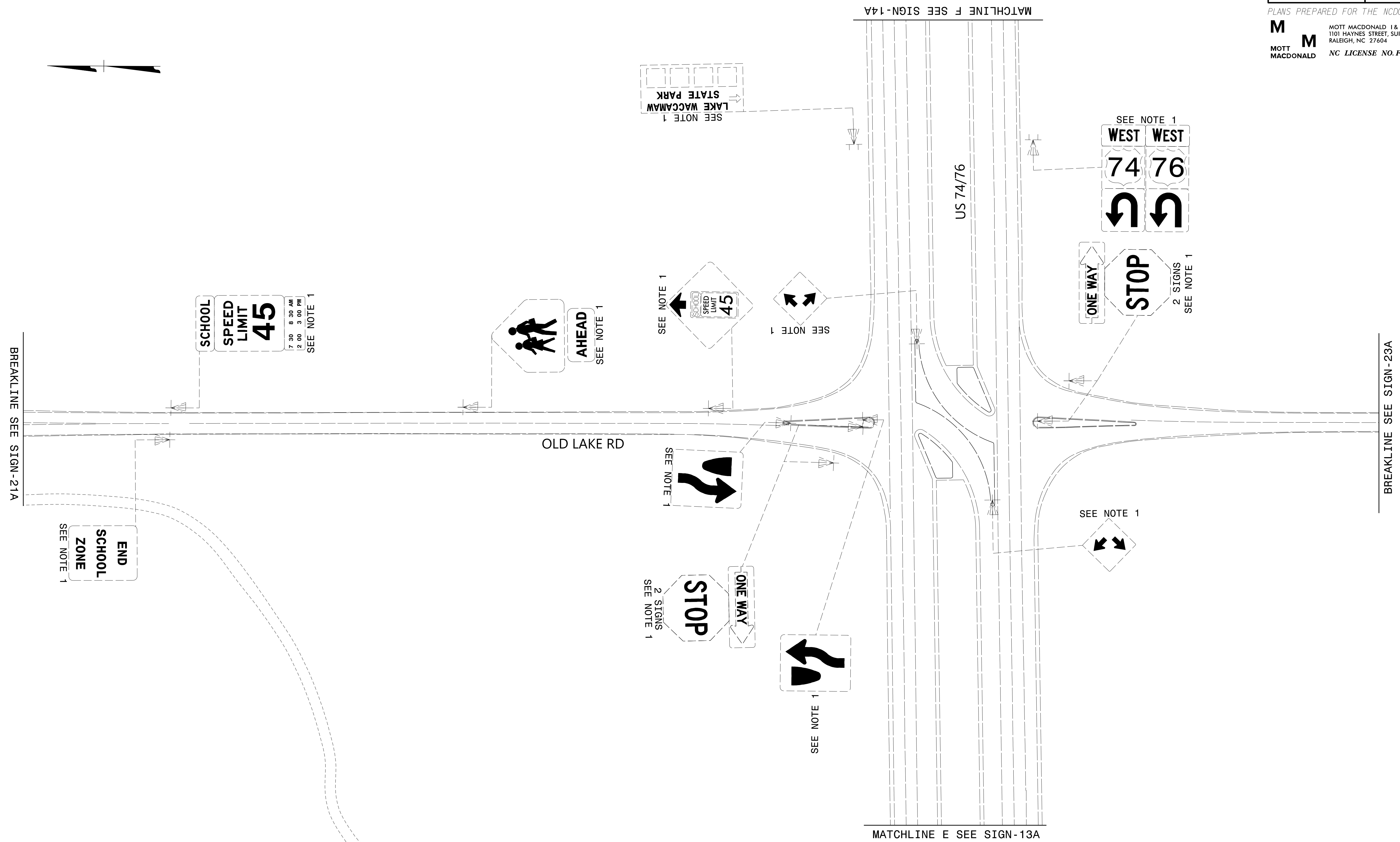
M MOTT MACDONALD I & E, LLC
 1101 HAYNES STREET, SUITE 101
 RALEIGH, NC 27604
M MOTT MACDONALD NC LICENSE NO. F-0669

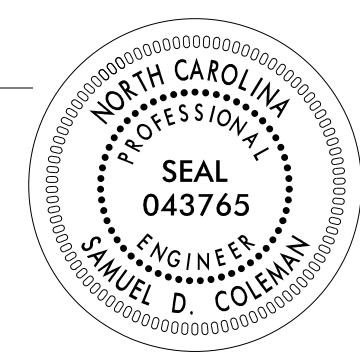

4/14/2022
 G:\501406565_Calyx_R5819_R5820\Tr-offic\Signing\CADD\Signing_Layout_Plans\R-5819_R-5820_Sgn_Sgn_22a.dgn
 User:COL85144

APPROVED: _____ DATE: _____ SEAL 		<p>EXISTING SIGNING DETAIL SHEET</p>
<p>DOCUMENT NOT CONSIDERED FINAL UNLESS ALL SIGNATURES COMPLETED</p>		

PROJ. REFERENCE NO.	SHEET NO.
R-5819 R-5820	SIGN-23

PLANS PREPARED FOR THE NCDOT BY:

M MOTT MACDONALD I & E, LLC
 1101 HAYNES STREET, SUITE 101
 RALEIGH, NC 27604
M MOTT MACDONALD NC LICENSE NO. F-0669

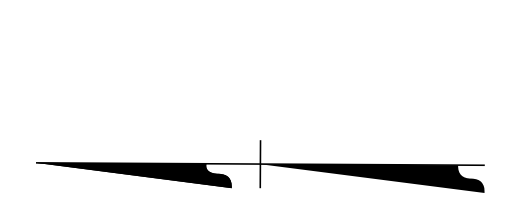

BREAKLINE - Y2 - STA 33+62 SEE SIGN-22

GREU TL-3

GREU TL-3

OLD LAKE RD

SPEED
LIMIT
35

409

BEGIN CONSTRUCTION
-Y2- POT STA 28+10

30

25

20

4/14/2022
 G:\501406565_Calyx_R5819_R5820\Tr-office\Signing\CADD\Signing Layout Plans\R-5819_R-5820_Sgn_SGN_23.dgn
 User:COL85144

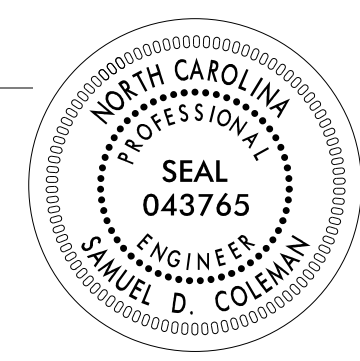
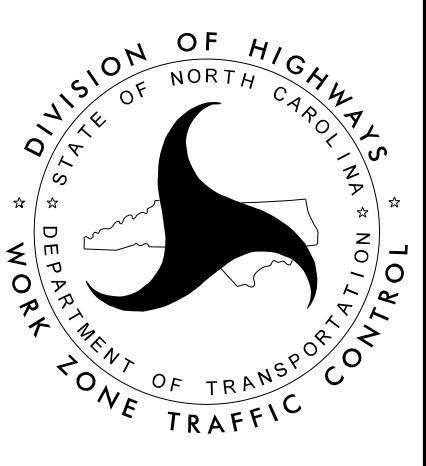
<p>APPROVED: _____</p> <p>DATE: _____</p> <p>SEAL</p> 		<p>PROPOSED SIGNING DETAIL SHEET</p>
<p>DOCUMENT NOT CONSIDERED FINAL UNLESS ALL SIGNATURES COMPLETED</p>		

PROJ. REFERENCE NO.	SHEET NO.
R-5819 R-5820	SIGN-23A

PLANS PREPARED FOR THE NCDOT BY:
M MOTT MACDONALD I & E, LLC
 1101 HAYNES STREET, SUITE 101
 RALEIGH, NC 27604
M MOTT MACDONALD NC LICENSE NO. F-0669

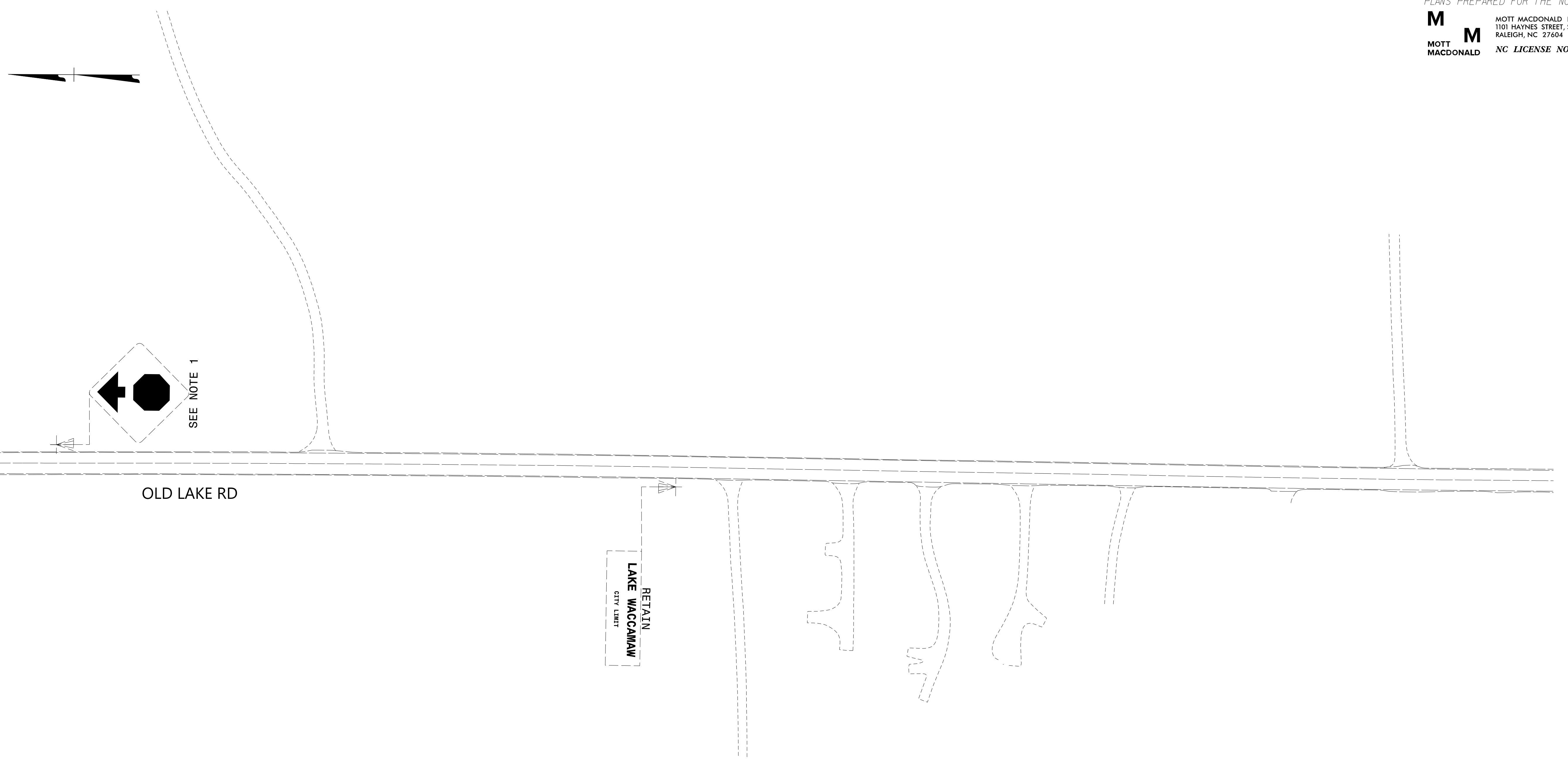

BREAKLINE SEE SIGN-22A

OLD LAKE RD

RETAIN
LAKE WACCAMAW
CITY LIMIT

APPROVED: _____
 DATE: _____

SEAL

**DOCUMENT NOT CONSIDERED FINAL
UNLESS ALL SIGNATURES COMPLETED**

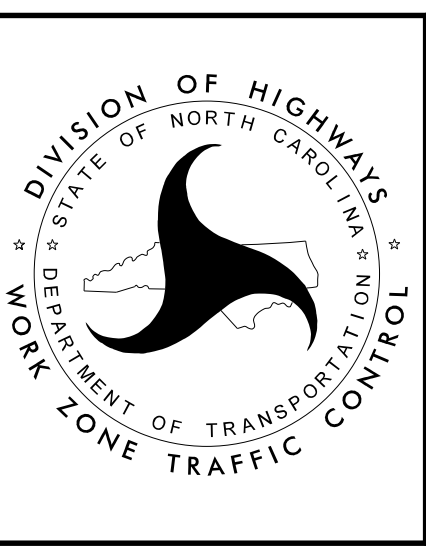

EXISTING
SIGNING DETAIL SHEET