

**This electronic collection of documents is provided
for the convenience of the user
and is Not a Certified Document –**

**The documents contained herein were originally issued
and sealed by the individuals whose names and license
numbers appear on each page, on the dates appearing
with their signature on that page.**

**This file or an individual page
shall not be considered a certified document.**

PLANS PREPARED FOR THE NCDOT BY:

M MOTT MACDONALD I & E, LLC
1101 HAYNES STREET, SUITE 101
RALEIGH, NC 27604
NC LICENSE NO. F-0669

SEE TMP-31 AND TMP-32 FOR
WORK BEGUN ON -Y1-, -Y1ROUND2-
AND -Y1RPA- IN PHASE II

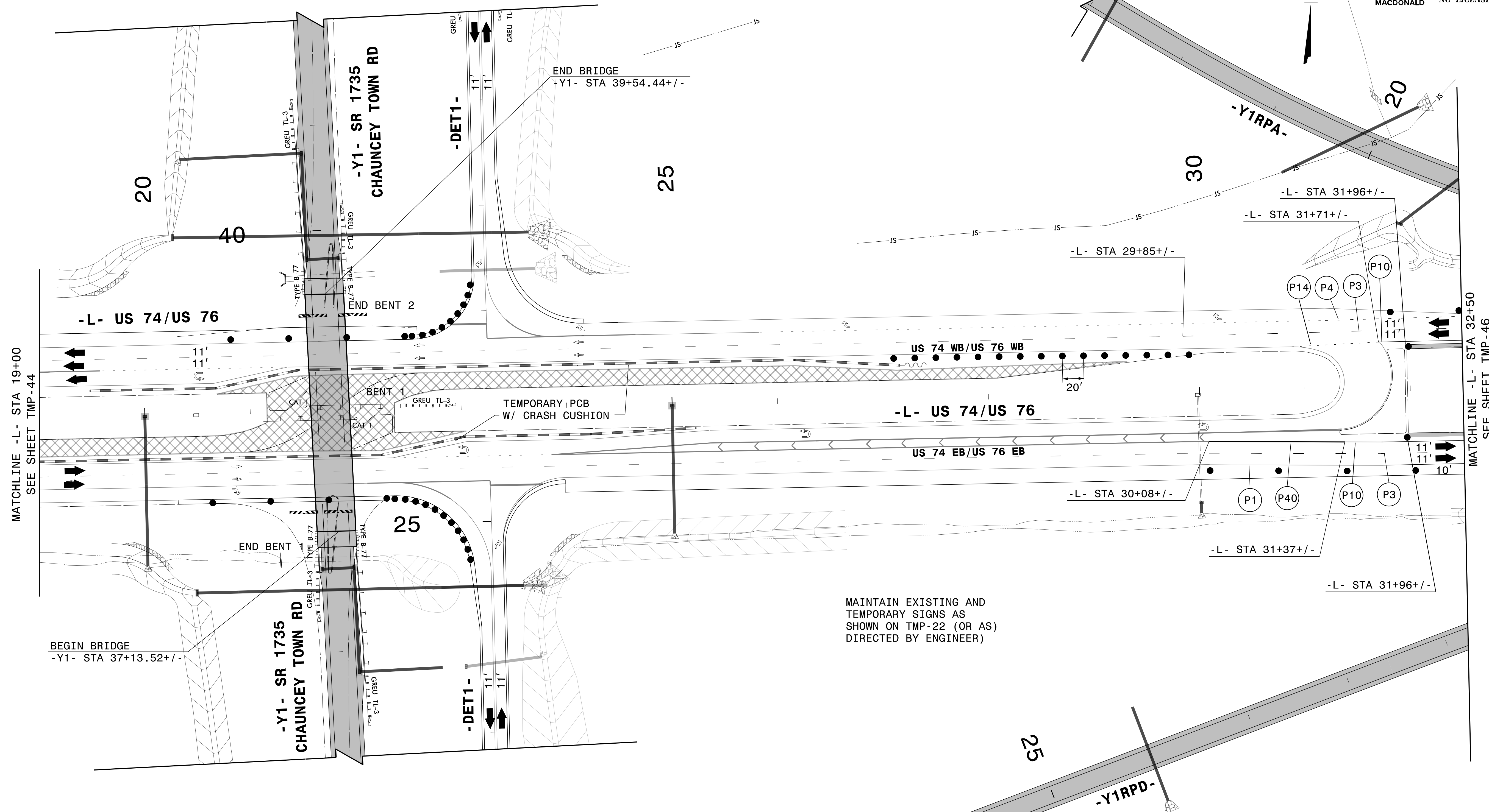

MAINTAIN EXISTING AND
TEMPORARY SIGNS AS
SHOWN ON TMP-22 (OR AS)
DIRECTED BY ENGINEER)

SEE TMP-29 AND TMP-30 FOR
WORK BEGUN ON -Y1-, -Y1ROUND1-
AND -Y1RPD- IN PHASE II

3/14/2022
G:\501406565_Calyx_R5819_R5820\TrafficControl\CPNR-5819_R-5820_TC_TMP_45_P3.dgn
User:ST086227

APPROVED: *Lori D Stoucho*
DATE: 4/13/2022

DocuSigned by:
Lori D Stoucho
7A92E46FD7874C7...



**TEMPORARY TRAFFIC CONTROL
AREA 2
PHASE III**

**DOCUMENT NOT CONSIDERED FINAL
UNLESS ALL SIGNATURES COMPLETED**

PLANS PREPARED FOR THE NCDOT BY:

M MOTT MACDONALD I & E, LLC
1101 HAYNES STREET, SUITE 101
RALEIGH, NC 27604
MOTT MACDONALD NC LICENSE NO. F-0669

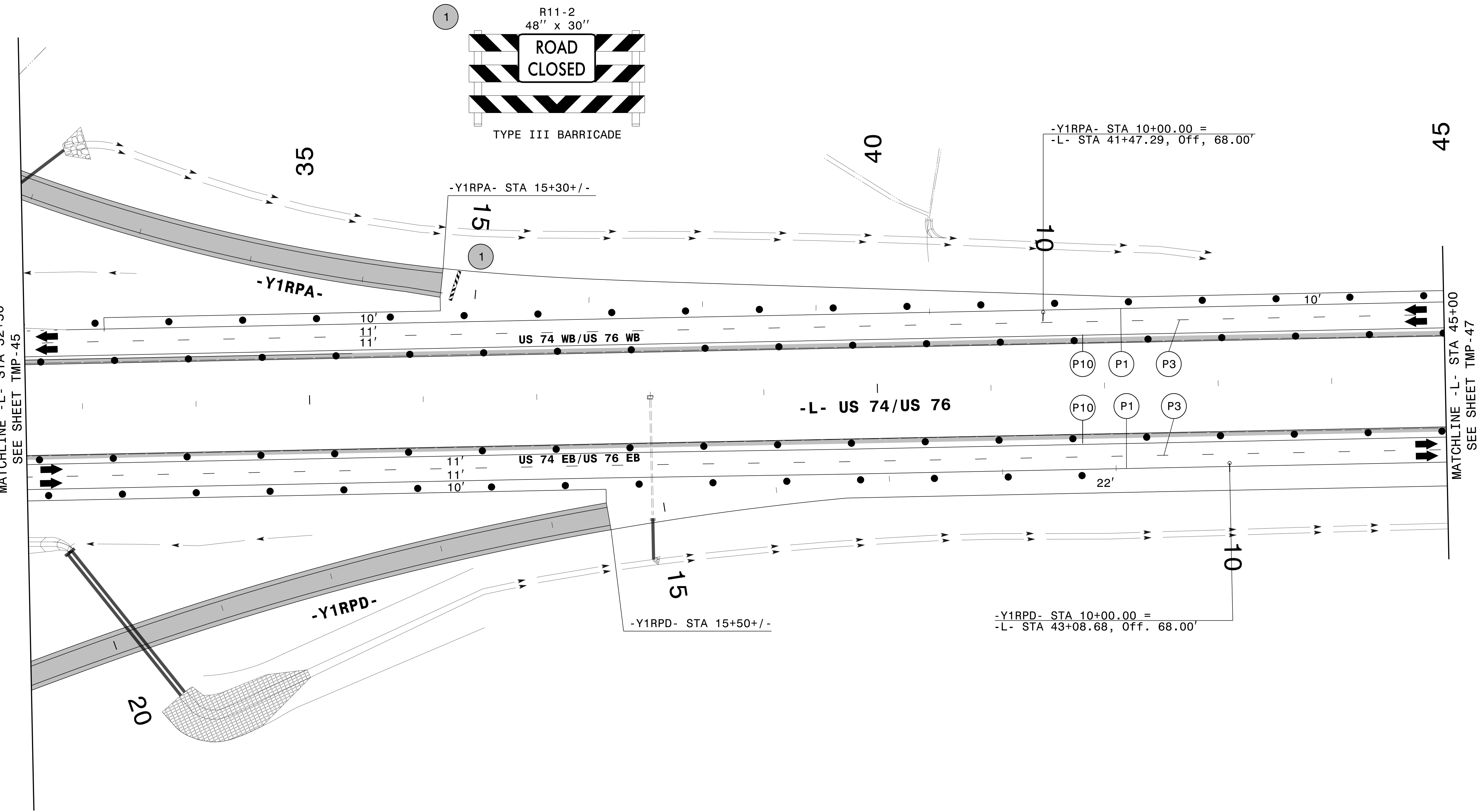
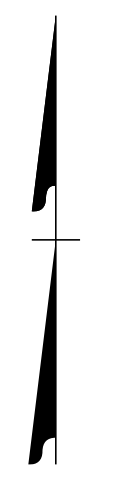

3/14/2022
G:\501406565_Calyx_R5819_R5820\TrafficControl\CPNR-5819_R-5820_TC-TMP-TMP_46_P3.dgn
User:STO86227

APPROVED: *Lori D Stoucho*
DATE: 4/13/2022

DOCUMENT NOT CONSIDERED FINAL
UNLESS ALL SIGNATURES COMPLETED



TEMPORARY TRAFFIC CONTROL
AREA 2
PHASE III

PROJ. REFERENCE NO.	SHEET NO.
R-5819 R-5820	TMP-47

PLANS PREPARED FOR THE NCDOT BY:
M MOTT MACDONALD I & E, LLC
 1101 HAYNES STREET, SUITE 101
 RALEIGH, NC 27604
M MOTT MACDONALD NC LICENSE NO. F-0669



45

50

55

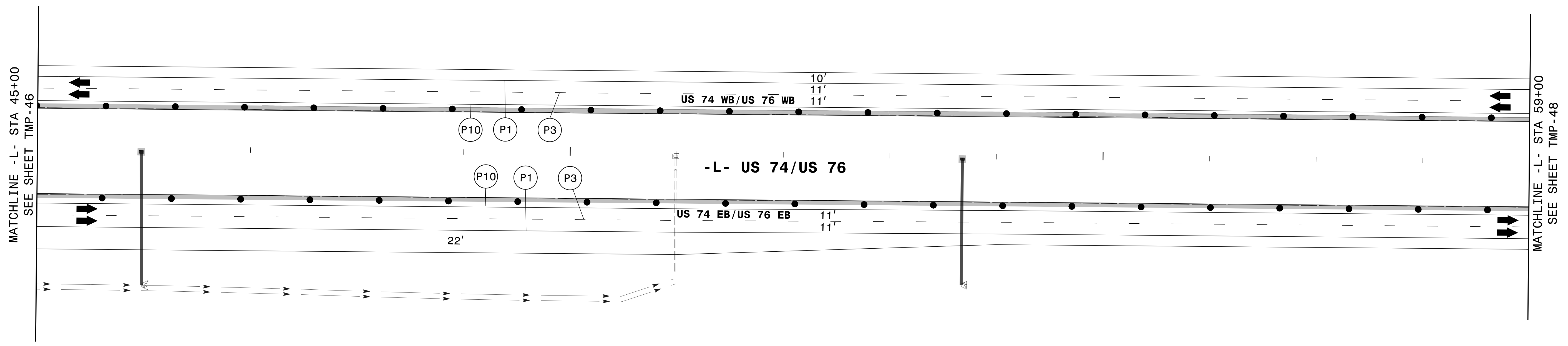

3/14/2022
 G:\501406565_Calyx_R5819_R5820\TrafficControl\TrafficControl\TC_TMP_47_P3.dgn
 User:ST086227

APPROVED: *Lois D. Stoucho*
DocuSigned by:
Lois D. Stoucho
7A92E40FD7874C7...

DATE: 4/13/2022

**DOCUMENT NOT CONSIDERED FINAL
UNLESS ALL SIGNATURES COMPLETED**

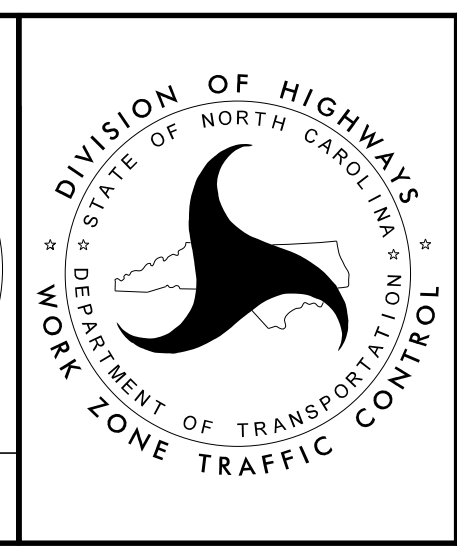

**TEMPORARY TRAFFIC CONTROL
AREA 2
PHASE III**

PROJ. REFERENCE NO.	SHEET NO.
R-5819 R-5820	TMP-48

PLANS PREPARED FOR THE NCDOT BY:

M MOTT MACDONALD I & E, LLC
 1101 HAYNES STREET, SUITE 101
 RALEIGH, NC 27604

M MOTT MACDONALD
 NC LICENSE NO. F-0669

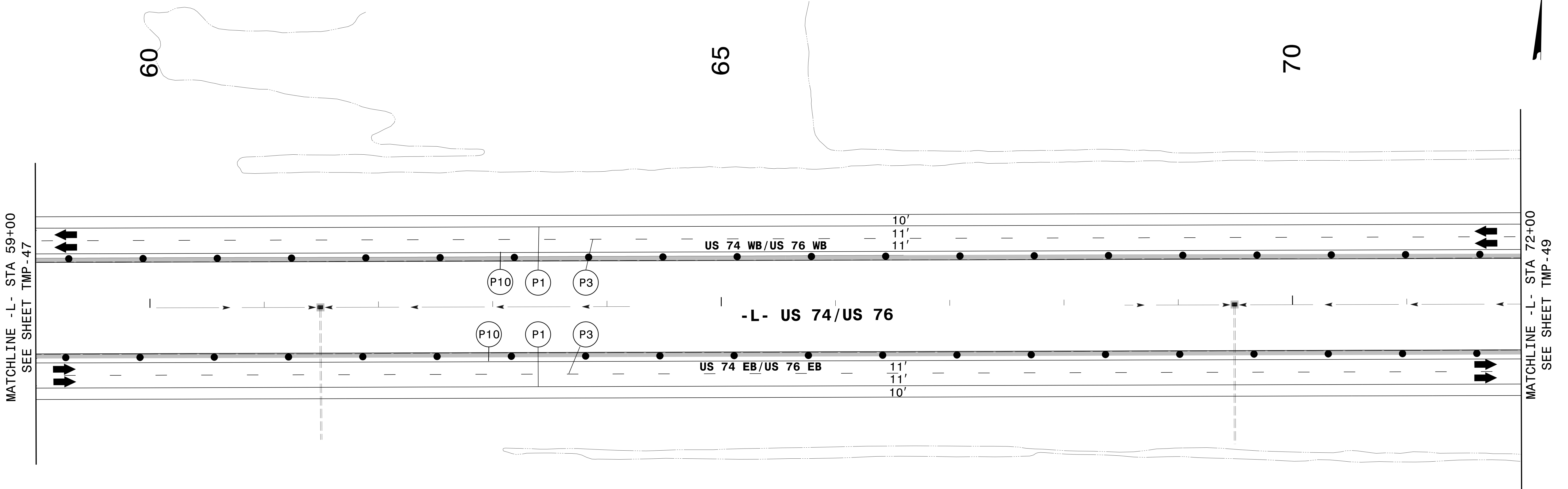

3/14/2022
 G:\501406565_Calyx_R5819_R5820\TrafficControl\CPNR-5819_R-5820_TC-TMP_TMP_48_P3.dgn
 User:ST086227

APPROVED: *Lori D Stouchko*
DocuSigned by:
Lori D Stouchko
7A82E46FD7874C7...

DATE: 4/13/2022

**DOCUMENT NOT CONSIDERED FINAL
 UNLESS ALL SIGNATURES COMPLETED**

**TEMPORARY TRAFFIC CONTROL
 AREA 2
 PHASE III**

PROJ. REFERENCE NO.	SHEET NO.
R-5819 R-5820	TMP-49

PLANS PREPARED FOR THE NCDOT BY:
M
MOTT MACDONALD & E, LLC
 1101 HAYNES STREET, SUITE 101
 RALEIGH, NC 27604
M
MOTT MACDONALD NC LICENSE NO. F-0669

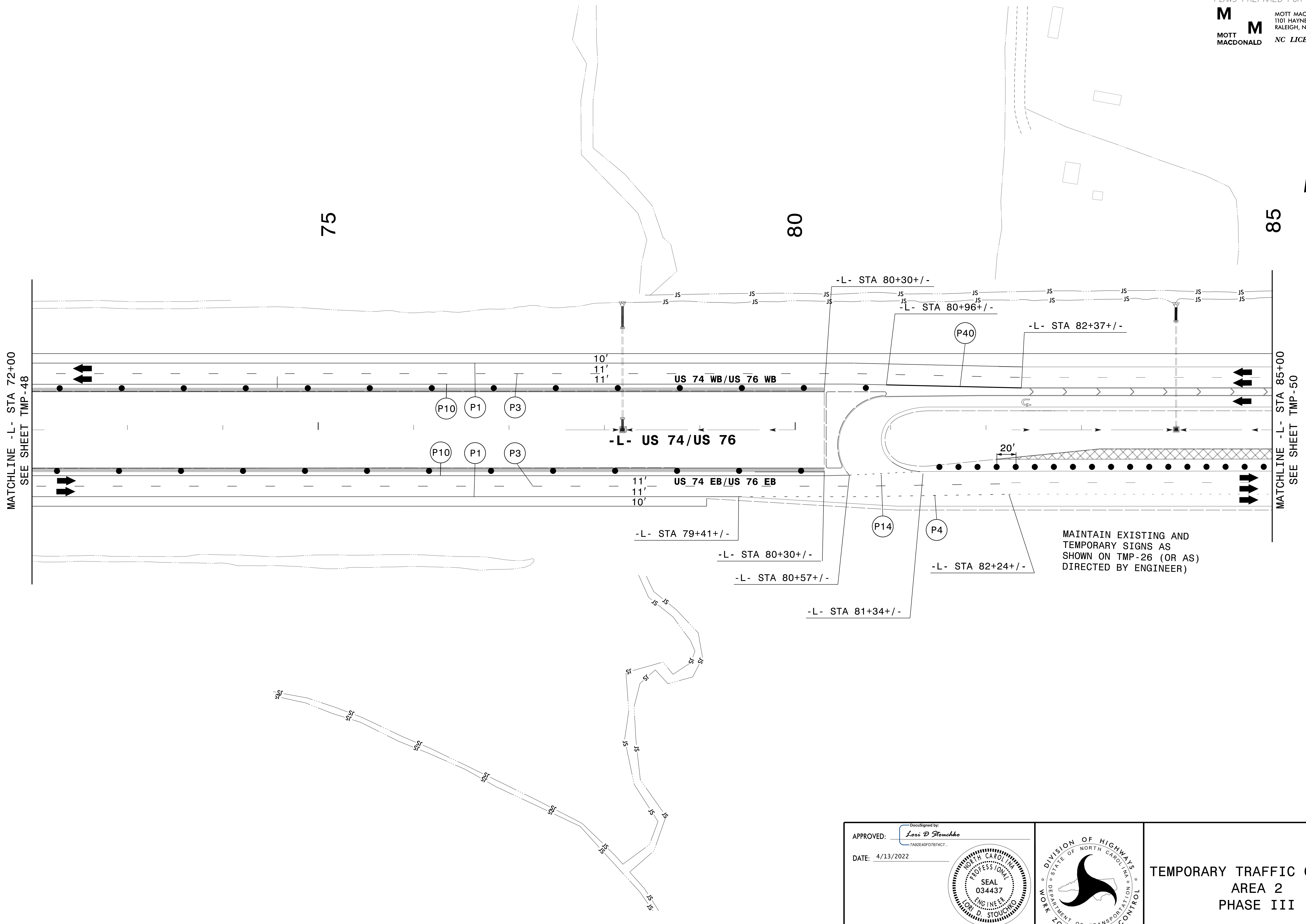

MATCHLINE -L- STA 72+00
SEE SHEET TMP-48

MATCHLINE -L- STA 85+00
SEE SHEET TMP-50

MAINTAIN EXISTING AND TEMPORARY SIGNS AS SHOWN ON TMP-26 (OR AS DIRECTED BY ENGINEER)

3/14/2022
G:\501406565_Calyx_R-5819_R-5820\TrafficControl\TrafficControl\NCPNR-5819_R-5820_TC_TMP_49_P3.dgn
User:ST086227

APPROVED: *Lois D. Stouchko*
7A92E40FD7874C7...
 DATE: 4/13/2022

**DOCUMENT NOT CONSIDERED FINAL
UNLESS ALL SIGNATURES COMPLETED**

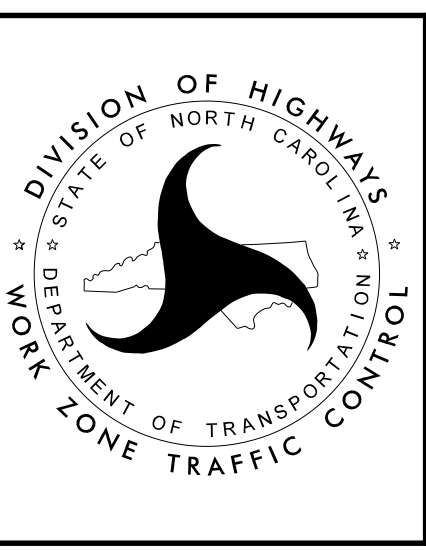

**TEMPORARY TRAFFIC CONTROL
AREA 2
PHASE III**

SEE TMP-34 AND TMP-35
 FOR WORK ON -Y2- BEGUN
 IN PHASE II

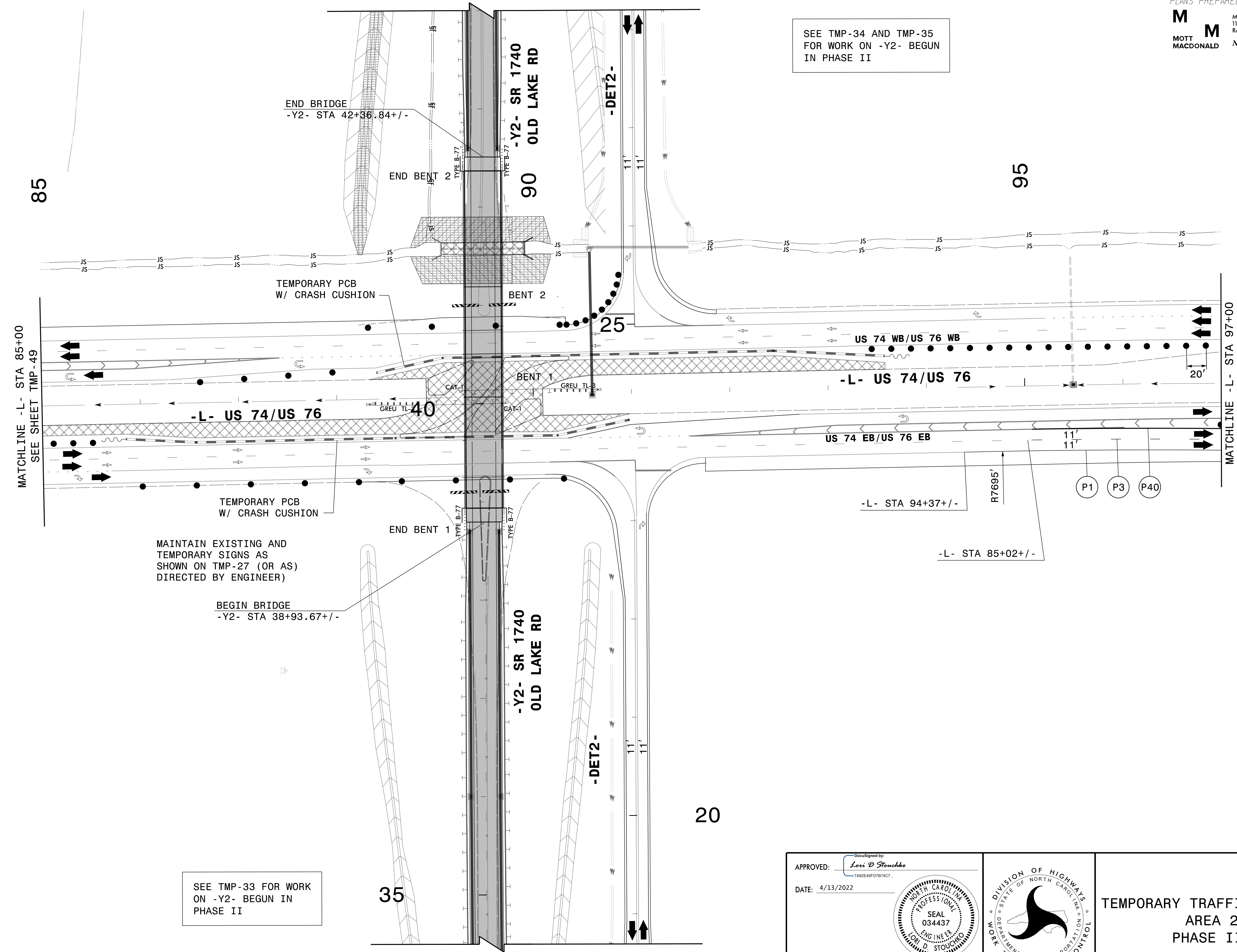

MAINTAIN EXISTING AND
 TEMPORARY SIGNS AS
 SHOWN ON TMP-27 (OR AS)
 DIRECTED BY ENGINEER)

SEE TMP-33 FOR WORK
 ON -Y2- BEGUN IN
 PHASE II

APPROVED: *Lori D Stoucho*
 DATE: 4/13/2022

Seal: NORTH CAROLINA PROFESSIONAL ENGINEER SEAL 034437 LOW D. STOUCHO

DOCUMENT NOT CONSIDERED FINAL UNLESS ALL SIGNATURES COMPLETED

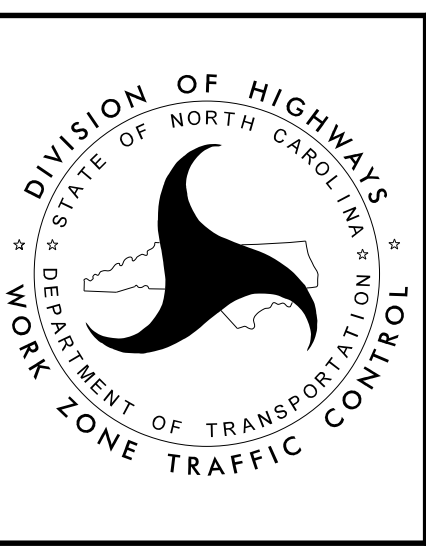

TEMPORARY TRAFFIC CONTROL
 AREA 2
 PHASE III

3/14/2022
 G:\501406565_Calvx_R5819_R5820\TrafficControl\CPNR-5819_R-5820_TC_TMP_50_P3.dgn
 User:ST086227

PROJ. REFERENCE NO.	SHEET NO.
R-5819 R-5820	TMP-51

PLANS PREPARED FOR THE NCDOT BY:

M MOTT MACDONALD I & E, LLC
 1101 HAYNES STREET, SUITE 101
 RALEIGH, NC 27604

M MOTT MACDONALD
 NC LICENSE NO. F-0669

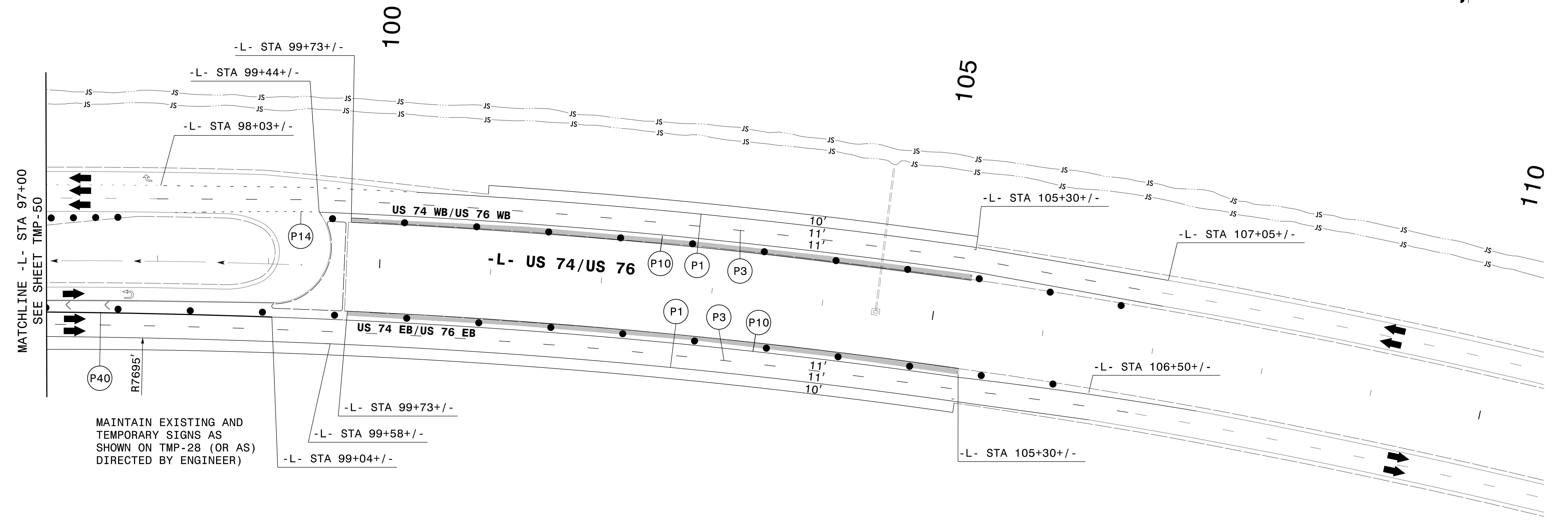

MAINTAIN EXISTING AND
 TEMPORARY SIGNS AS
 SHOWN ON TMP-28 (OR AS)
 DIRECTED BY ENGINEER)

3/14/2022
 G:\501406565_Calyx_R5819_R5820\TrafficControl\TrafficControl\TrafficControl\TC_TMP_51_P3.dgn
 User:ST08627

APPROVED: *Lori D. Stoucho*
 DATE: 4/13/2022

DocuSigned by:
 Lori D. Stoucho
 7A92E46F07874C7...

Professional Engineer Seal:
 NORTH CAROLINA PROFESSIONAL ENGINEER
 SEAL 034437
 LOW D. STOUCHO

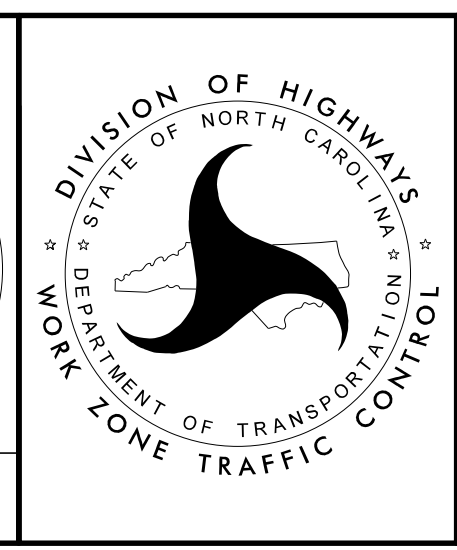

TEMPORARY TRAFFIC CONTROL
 AREA 2
 PHASE III

DOCUMENT NOT CONSIDERED FINAL
 UNLESS ALL SIGNATURES COMPLETED

SEE SHEETS TMP-32, TMP-37 THRU
TMP-40 FOR WORK BEGUN IN PHASE II

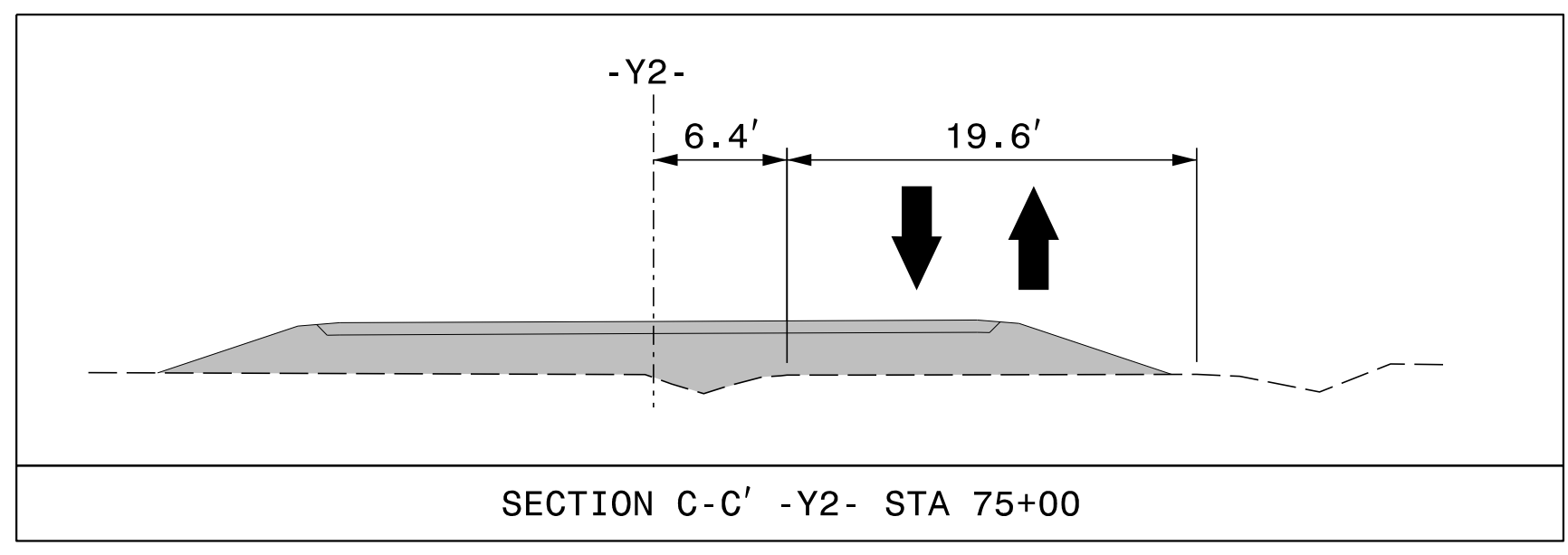
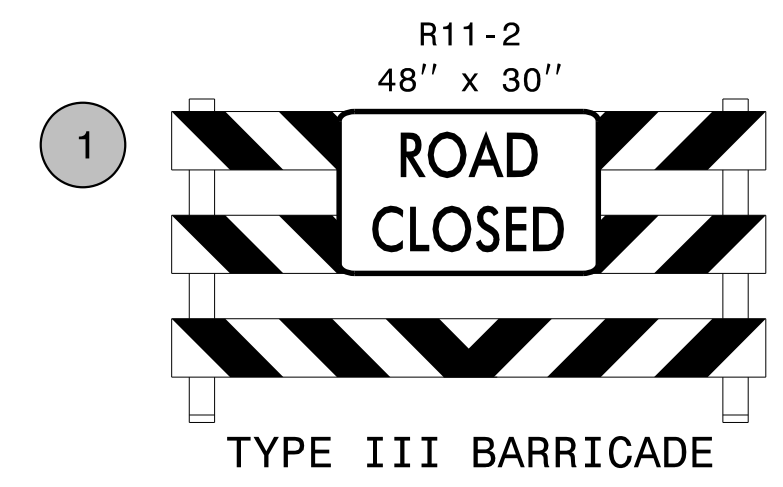
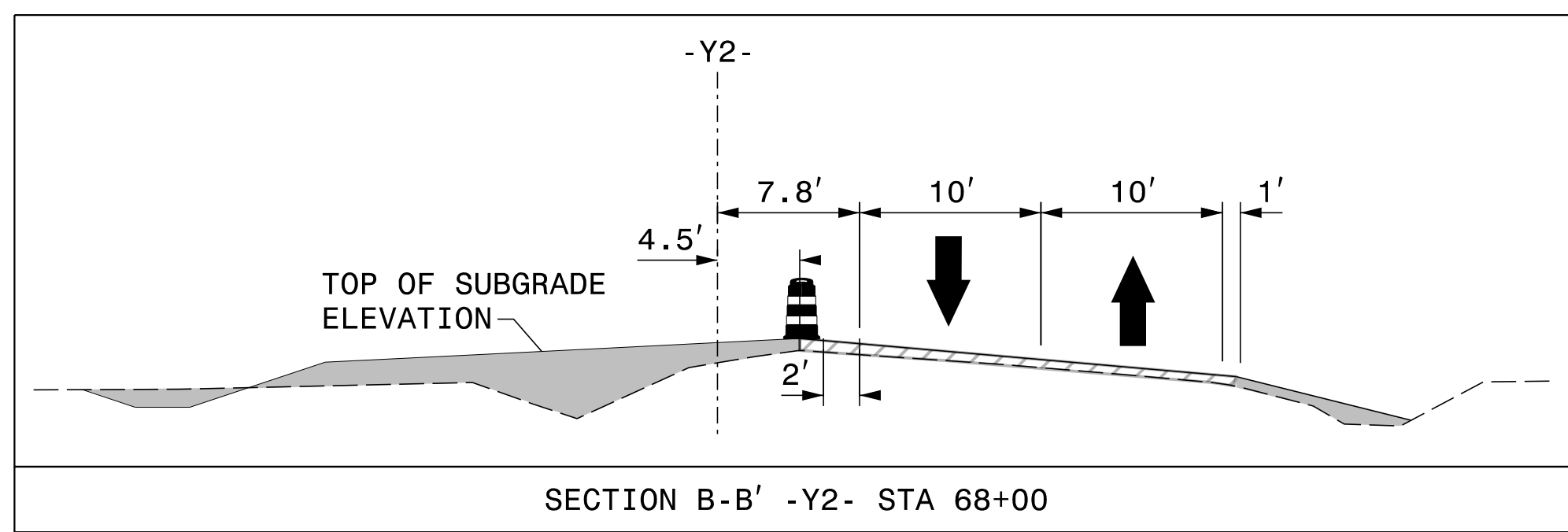
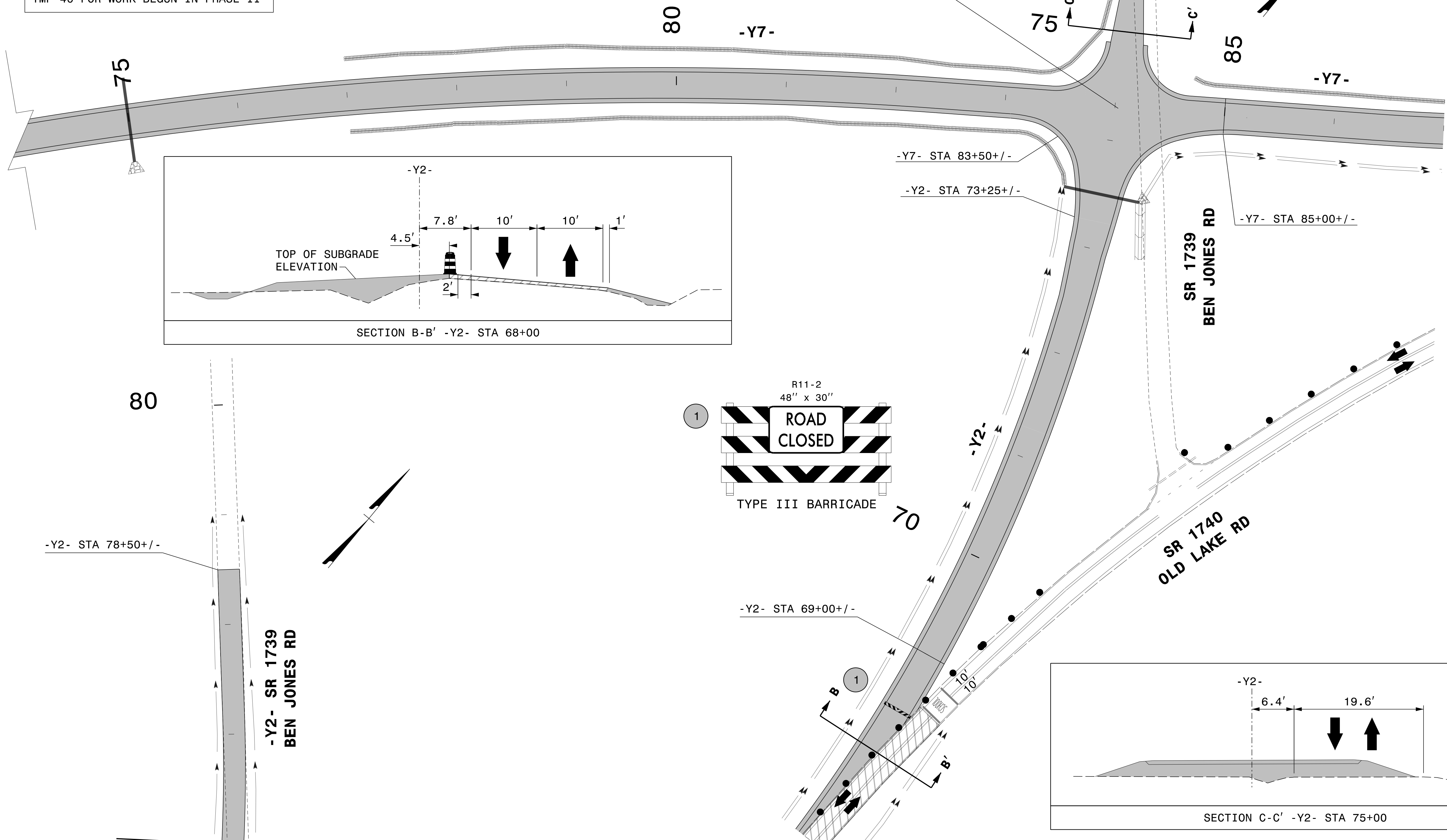

3/15/2022
G:\501406565_Calyx_R5819_R5820\TrafficControl\CPNR-5819_R-5820_TC_TMP_52_P3.dgn
User:ST086227

APPROVED: *Lori D Stoucho*
DATE: 4/13/2022

DOCUMENT NOT CONSIDERED FINAL
UNLESS ALL SIGNATURES COMPLETED

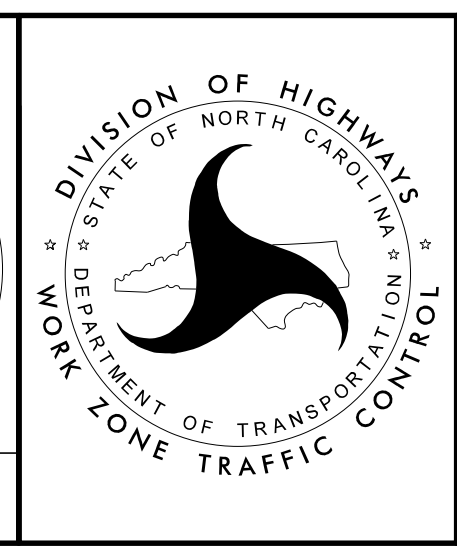

TEMPORARY TRAFFIC CONTROL
AREA 2
PHASE III

PROJ. REFERENCE NO.	SHEET NO.
R-5819 R-5820	TMP-53

PLANS PREPARED FOR THE NCDOT BY:

M MOTT MACDONALD I & E, LLC
 1101 HAYNES STREET, SUITE 101
 RALEIGH, NC 27604
M NC LICENSE NO. F-0669

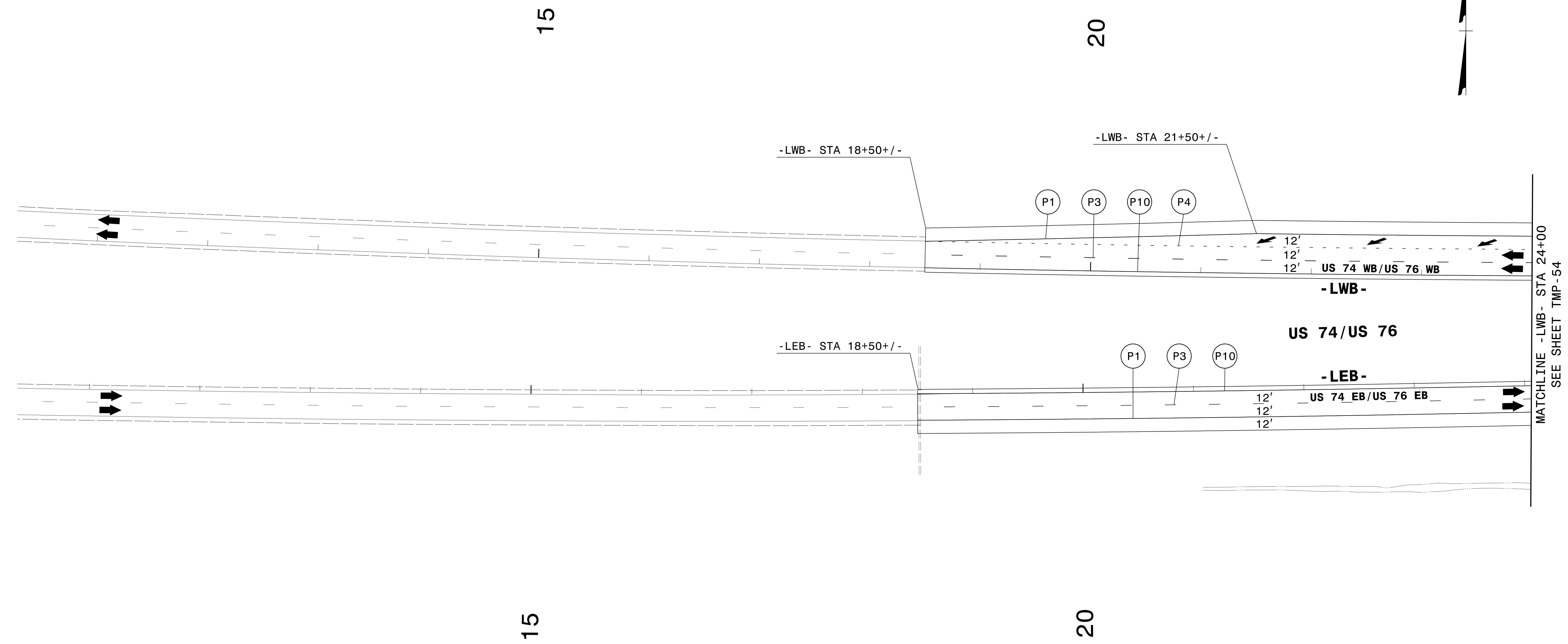

MATCHLINE -LWB- STA 24+00
SEE SHEET TMP-54

3/14/2022
G:\501406565_Calyx_R5819_R5820\TrafficControl\TrafficControl\CPNR-5819_R-5820_TC-TMP-TMP-53_P4A.dgn
User:ST086227

APPROVED: *Lori D. Stoucho*
 DATE: 4/13/2022

**DOCUMENT NOT CONSIDERED FINAL
UNLESS ALL SIGNATURES COMPLETED**

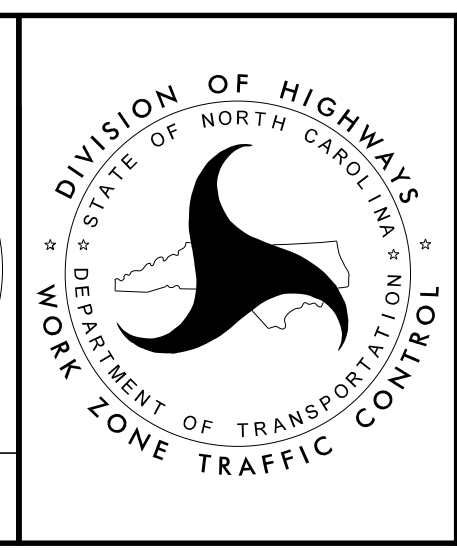

TEMPORARY TRAFFIC CONTROL
AREA 2
PHASE IVA

PLANS PREPARED FOR THE NCDOT BY:
M MOTT MACDONALD I & E, LLC
 1101 HAYNES STREET, SUITE 101
 RALEIGH, NC 27604
M
 MOTT MACDONALD NC LICENSE NO. F-0669

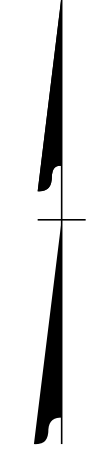
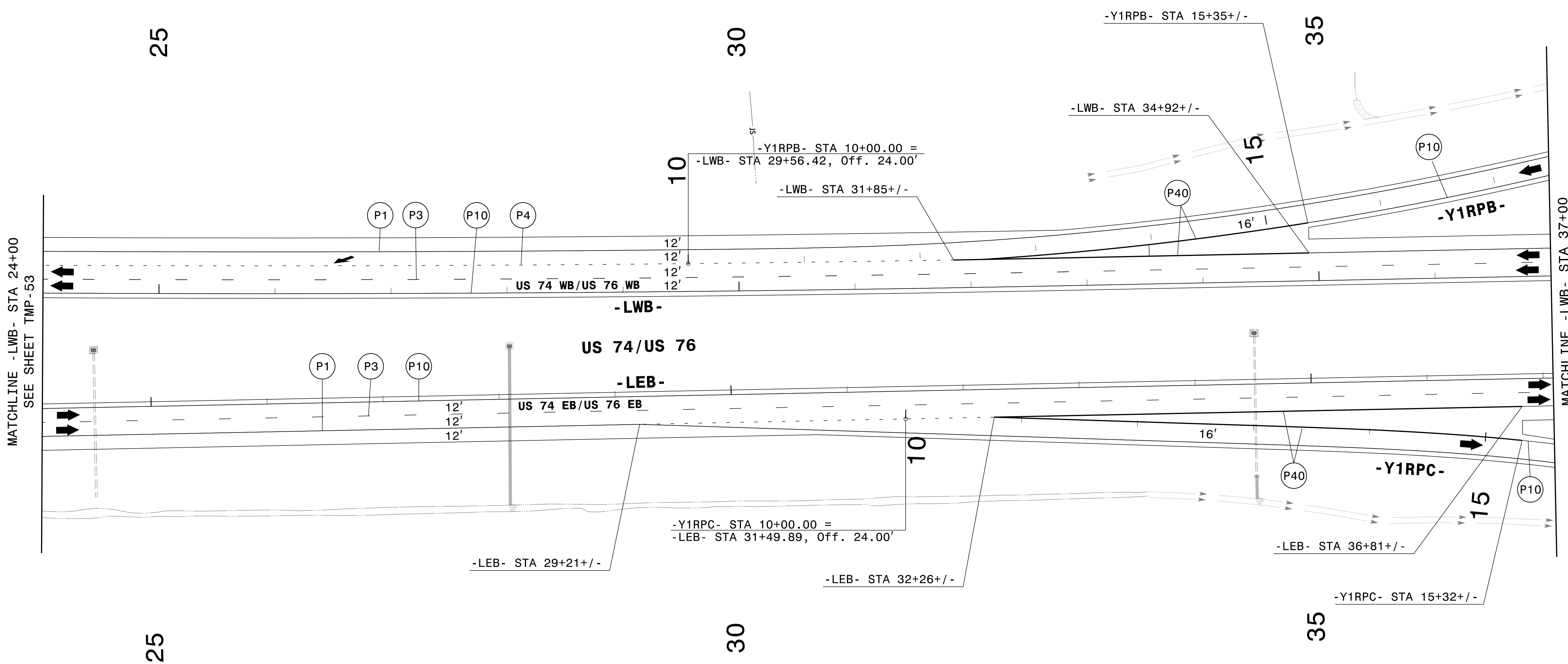

3/14/2022
 G:\501406565_Calyx_R5819_R5820\TrafficControl\CPNR-5819_R-5820\TC_TMP_54_P4A.dgn
 User:STO86227

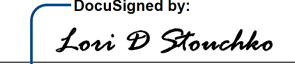
APPROVED:  Lari D. Stouchko
 DATE: 4/13/2022

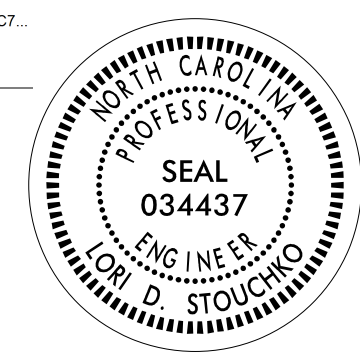

**DOCUMENT NOT CONSIDERED FINAL
 UNLESS ALL SIGNATURES COMPLETED**

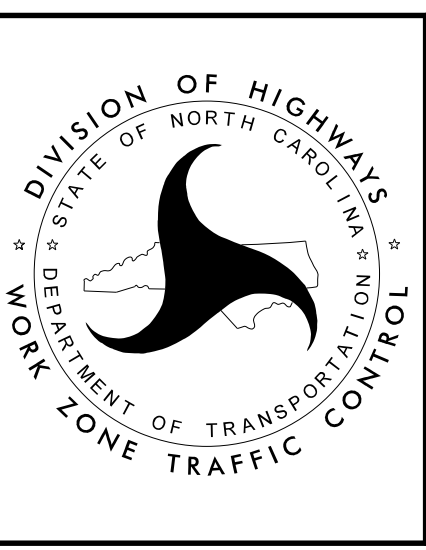

TEMPORARY TRAFFIC CONTROL
 AREA 2
 PHASE IVA

PROJ. REFERENCE NO.	SHEET NO.
R-5819 R-5820	TMP-55

PLANS PREPARED FOR THE NCDOT BY:

M MOTT MACDONALD I & E, LLC
 1101 HAYNES STREET, SUITE 101
 RALEIGH, NC 27604

M MOTT MACDONALD
 NC LICENSE NO. F-0669

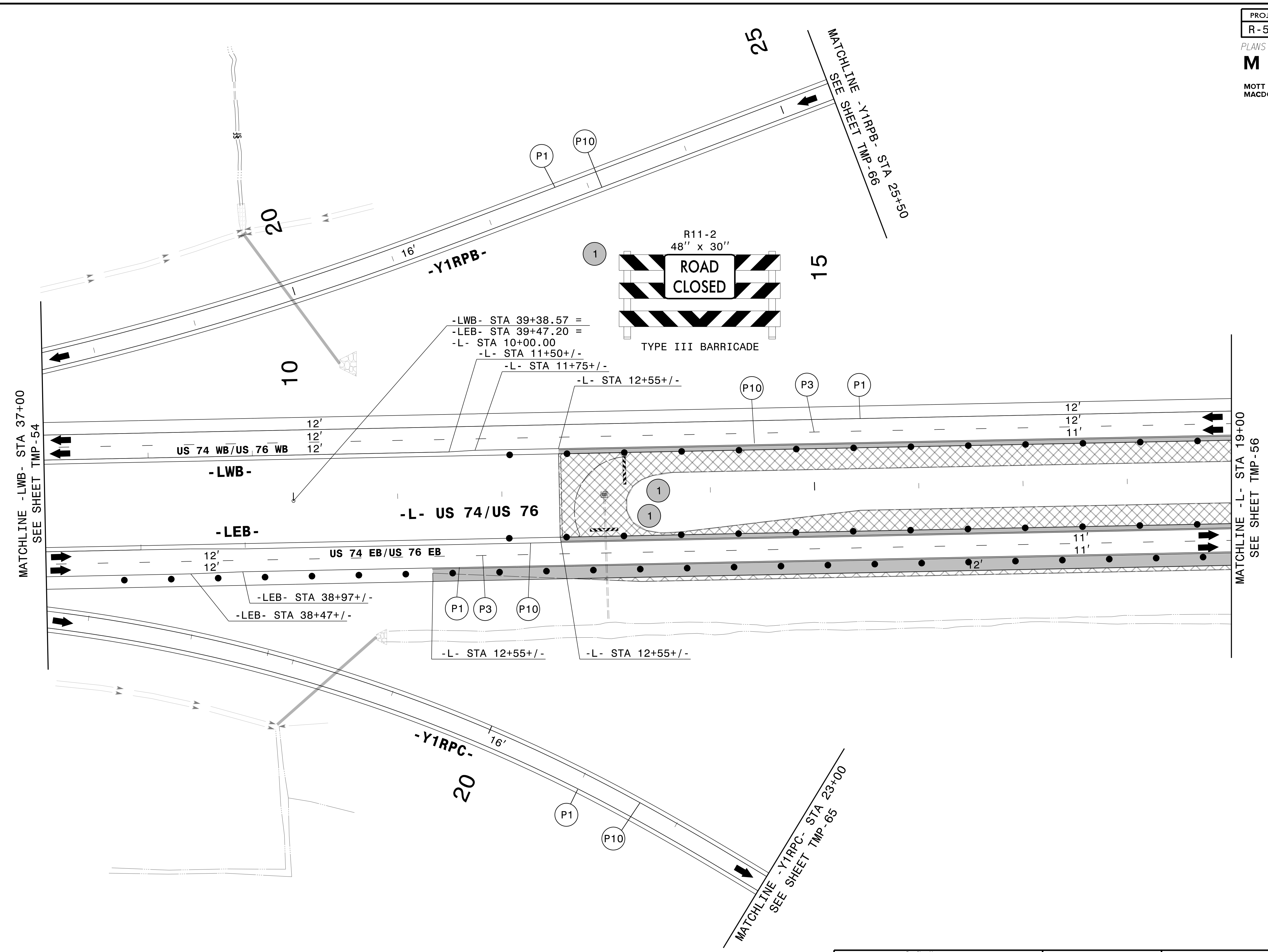
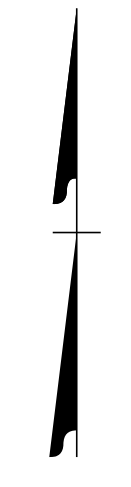

3/14/2022
 G:\501406565_Calyx_R5819_R5820\TrafficControl\TCP\N\R-5819_R-5820_TC_TMP_55_P4A.dgn
 User:ST086227

APPROVED: *Lori D Stoucho*
DocuSigned by:
Lori D Stoucho
7A92E46FD7874C7...

DATE: 4/13/2022

**DOCUMENT NOT CONSIDERED FINAL
UNLESS ALL SIGNATURES COMPLETED**



**TEMPORARY TRAFFIC CONTROL
 AREA 2
 PHASE IVA**

PLANS PREPARED FOR THE NCDOT BY:

M MOTT MACDONALD I & E, LLC
1101 HAYNES STREET, SUITE 101
RALEIGH, NC 27604
NC LICENSE NO. F-0669

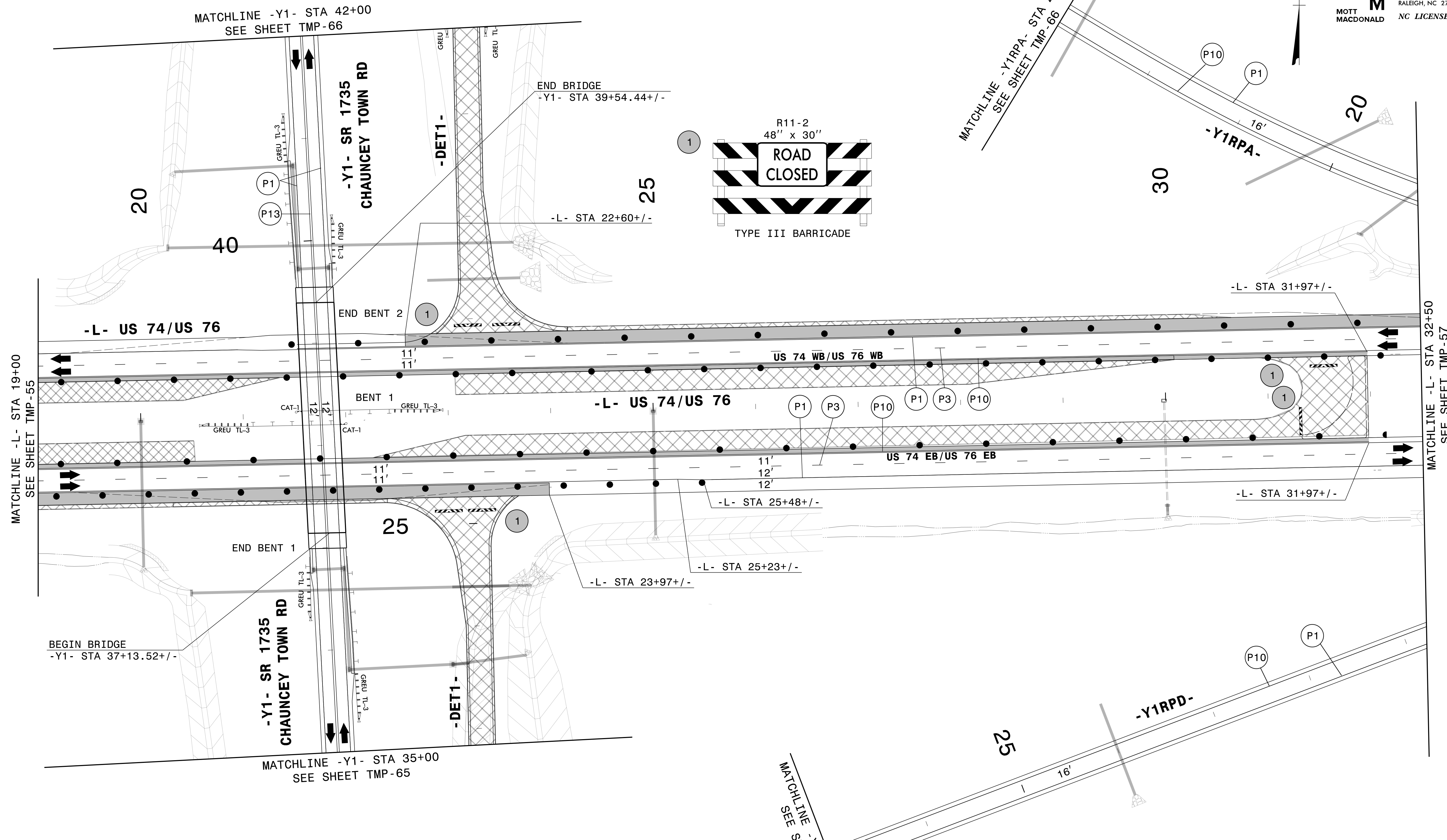

3/14/2022
 G:\501406565_Calyx_R5819_R5820\TrafficControl\TrafficControl\TC_TMP_56_P4A.dgn
 User:ST086227

APPROVED: *Lori D. Stoucho*
7A92E46FD7874C7

DATE: 4/13/2022

**DOCUMENT NOT CONSIDERED FINAL
UNLESS ALL SIGNATURES COMPLETED**

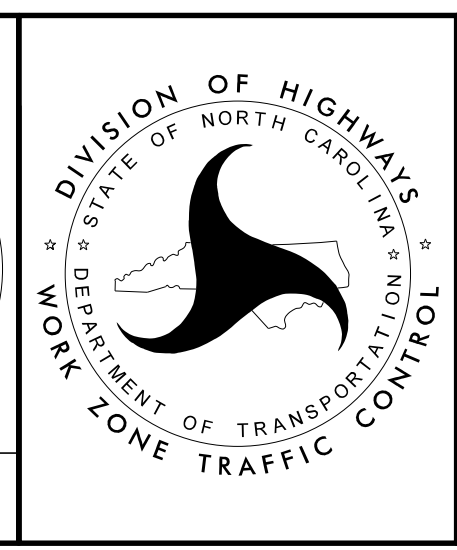

**TEMPORARY TRAFFIC CONTROL
AREA 2
PHASE IVA**

PROJ. REFERENCE NO.	SHEET NO.
R-5819 R-5820	TMP-57

PLANS PREPARED FOR THE NCDOT BY:

M MOTT MACDONALD I & E, LLC
 1101 HAYNES STREET, SUITE 101
 RALEIGH, NC 27604

M MOTT MACDONALD
 NC LICENSE NO. F-0669

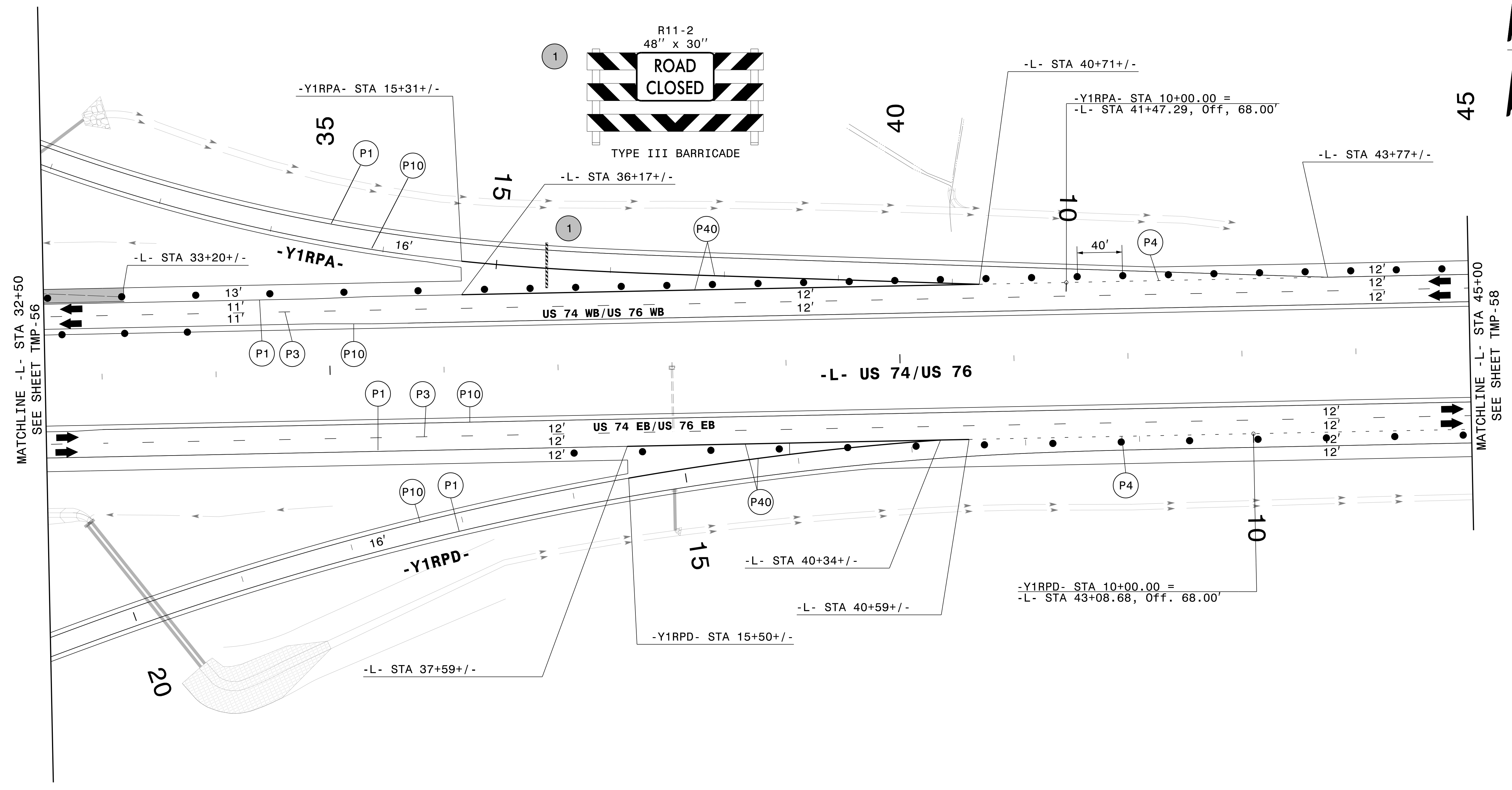
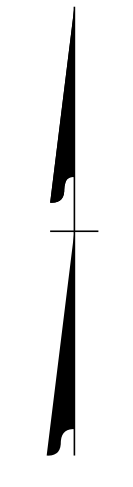

3/14/2022
 G:\501406565_Calyx_R5819_R5820\TrafficControl\CPNR-5819_R-5820_TC_TMP_57_P4A.dgn
 User:ST086227

APPROVED: *Lori D. Stoucho*
 DATE: 4/13/2022

**DOCUMENT NOT CONSIDERED FINAL
 UNLESS ALL SIGNATURES COMPLETED**

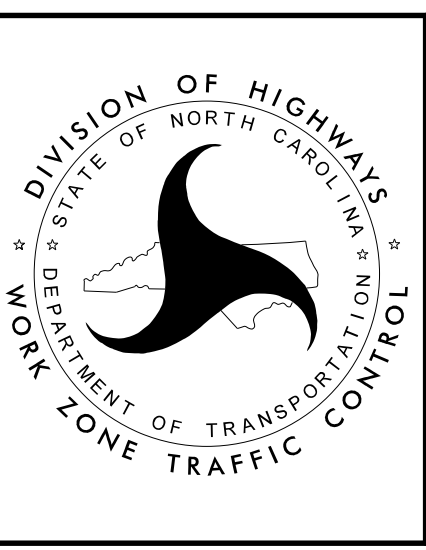

**TEMPORARY TRAFFIC CONTROL
 AREA 2
 PHASE IVA**

PROJ. REFERENCE NO.	SHEET NO.
R-5819 R-5820	TMP-58

PLANS PREPARED FOR THE NCDOT BY:

M MOTT MACDONALD I & E, LLC
 1101 HAYNES STREET, SUITE 101
 RALEIGH, NC 27604

M MOTT MACDONALD
 NC LICENSE NO. F-0669

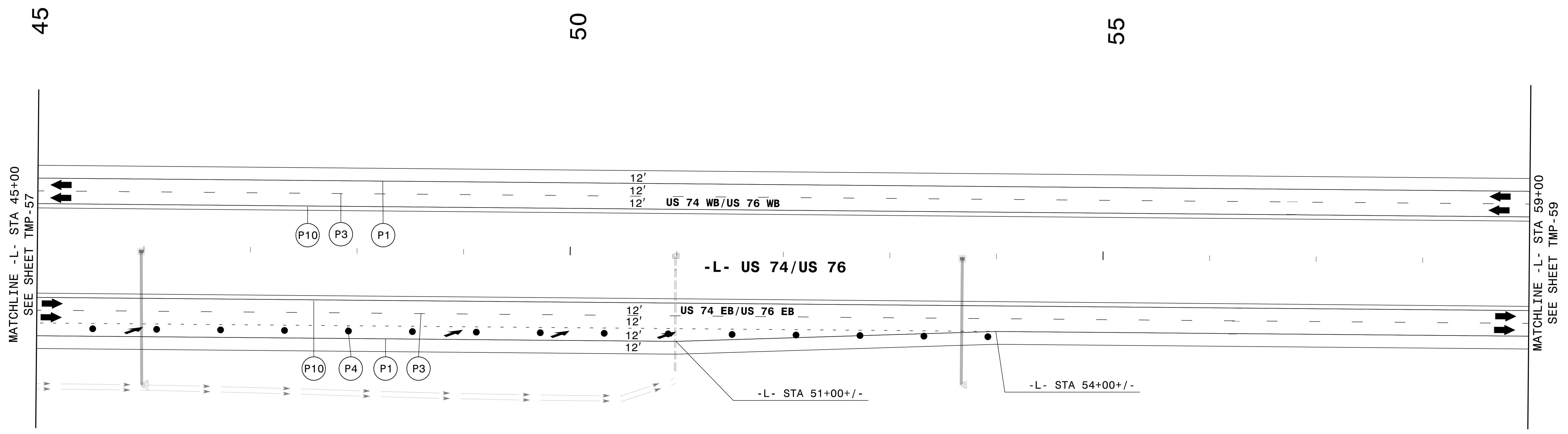

3/14/2022
 G:\501406565_Calyx_R5819_R5820\TrafficControl\TrafficControl\TC_TMP_58_P4A.dgn
 User:ST086227

APPROVED: *Lori D Stoucho*
DocuSigned by:
Lori D Stoucho
7A92E40FD7874C7...

DATE: 4/13/2022

**DOCUMENT NOT CONSIDERED FINAL
UNLESS ALL SIGNATURES COMPLETED**



**TEMPORARY TRAFFIC CONTROL
AREA 2
PHASE IVA**

PROJ. REFERENCE NO.	SHEET NO.
R-5819 R-5820	TMP-59

PLANS PREPARED FOR THE NCDOT BY:
M MOTT MACDONALD I & E, LLC
 1101 HAYNES STREET, SUITE 101
 RALEIGH, NC 27604
M MOTT MACDONALD NC LICENSE NO. F-0669

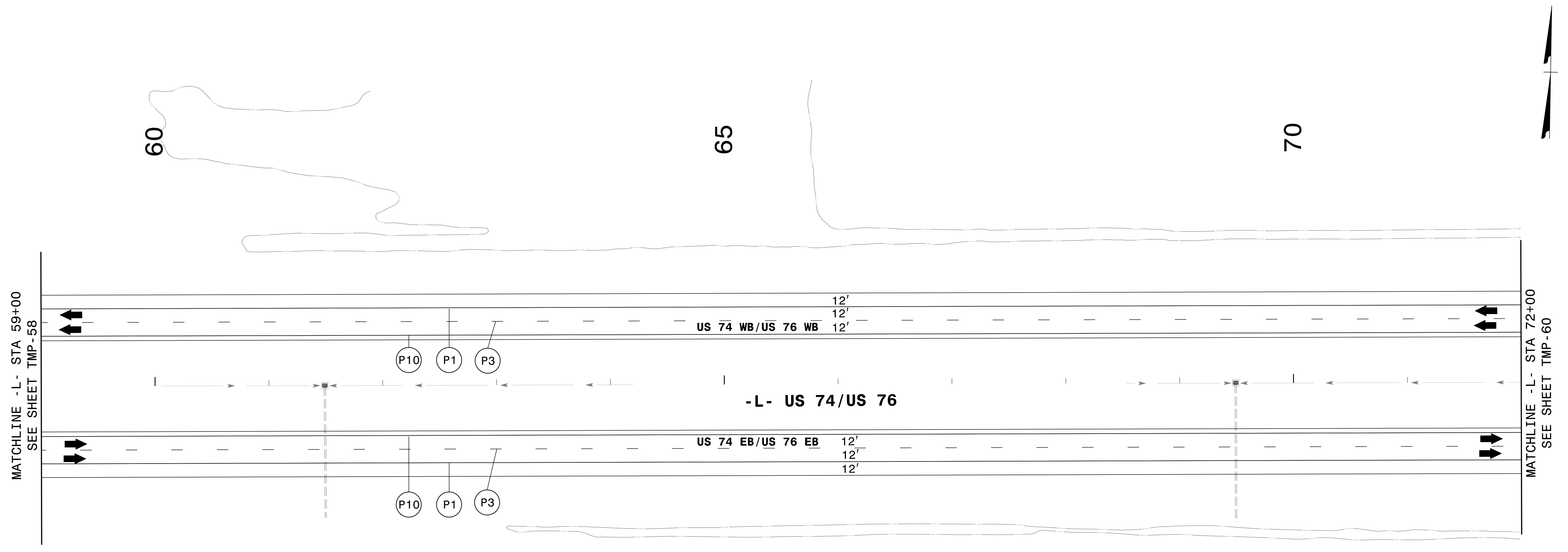

3/14/2022
 G:\501406565_Calyx_R5819_R5820\TrafficControl\TrafficControl\CPNR-5819_R-5820_TC_TMP_59_P4A.dgn
 User:ST086227

APPROVED: *Lori D. Stoucho*
DocuSigned by:
Lori D. Stoucho
7A92E40FD7874C7...

DATE: 4/13/2022

**DOCUMENT NOT CONSIDERED FINAL
UNLESS ALL SIGNATURES COMPLETED**

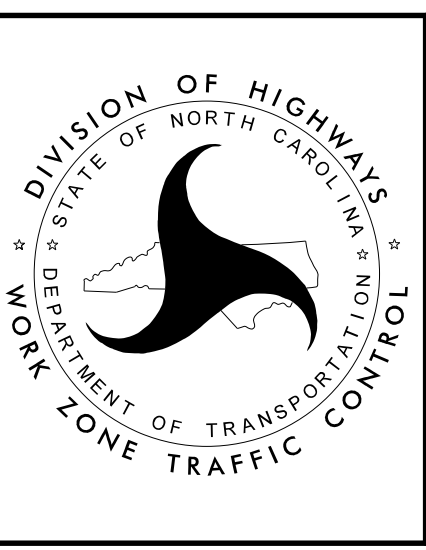

**TEMPORARY TRAFFIC CONTROL
AREA 2
PHASE IVA**

PROJ. REFERENCE NO.	SHEET NO.
R-5819 R-5820	TMP-60

PLANS PREPARED FOR THE NCDOT BY:

M MOTT MACDONALD I & E, LLC
1101 HAYNES STREET, SUITE 101
RALEIGH, NC 27604
NC LICENSE NO. F-0669

M MOTT MACDONALD

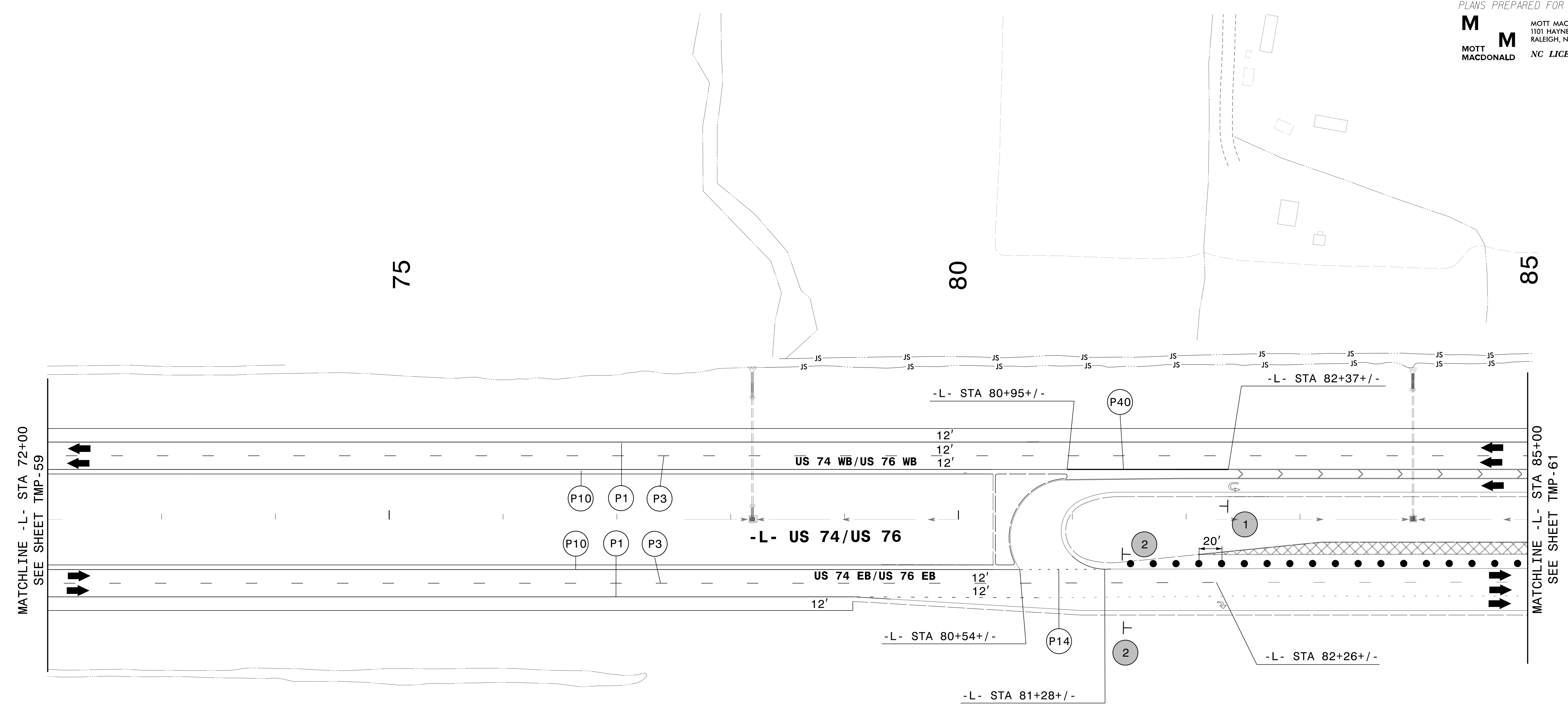
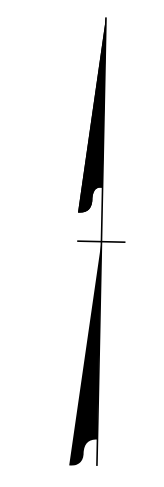

1	CHAUNCEY TOWN RD	SP-1	36" X 24"	2	CHAUNCEY TOWN RD	SP-1	36" X 24"
	DETOUR	M4-8	24" X 12"		DETOUR	M4-8	24" X 12"
		SP-3	21" X 21"			M5-1 R	21" X 15"

3/14/2022
G:\501406565_Calyx_R5819_R5820\TrafficControl\CPNR-5819_R-5820_TC_TMP_60_P4A.dgn
User:ST08627

APPROVED: *Lois D. Stoucho*
7AB2E46FD7874C7...

DATE: 4/13/2022

**DOCUMENT NOT CONSIDERED FINAL
UNLESS ALL SIGNATURES COMPLETED**

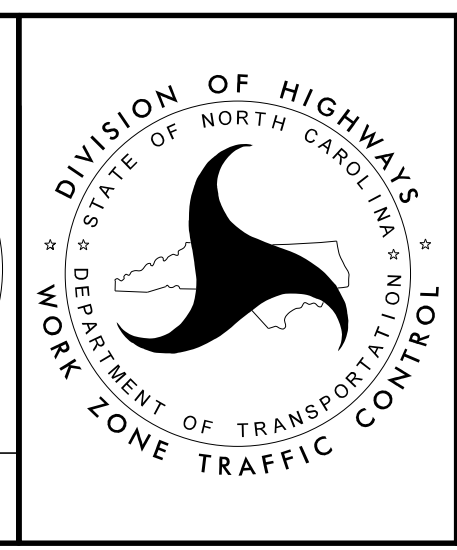

**TEMPORARY TRAFFIC CONTROL
AREA 2
PHASE IVA**

PLANS PREPARED FOR THE NCDOT BY:

M MOTT MACDONALD I & E, LLC
1101 HAYNES STREET, SUITE 101
RALEIGH, NC 27604
M MOTT MACDONALD NC LICENSE NO. F-0669

SEE TMP-34 AND TMP-35
FOR WORK ON -Y2- BEGUN
IN PHASE II

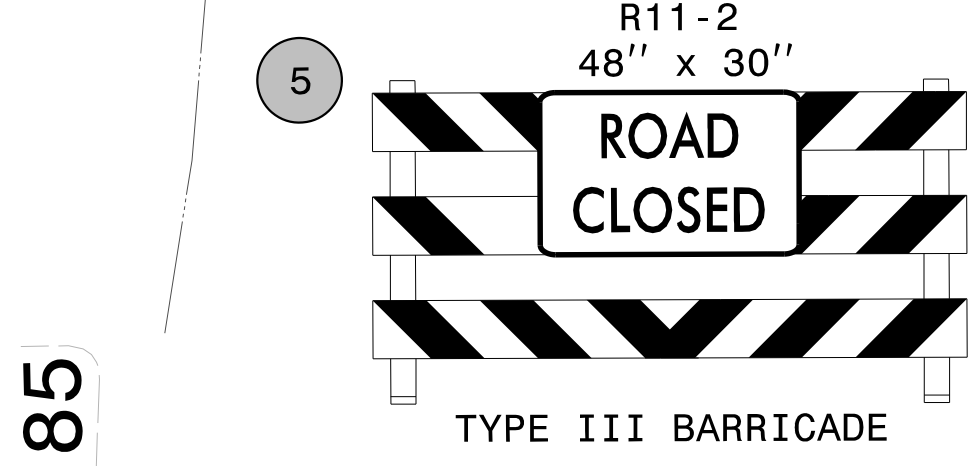
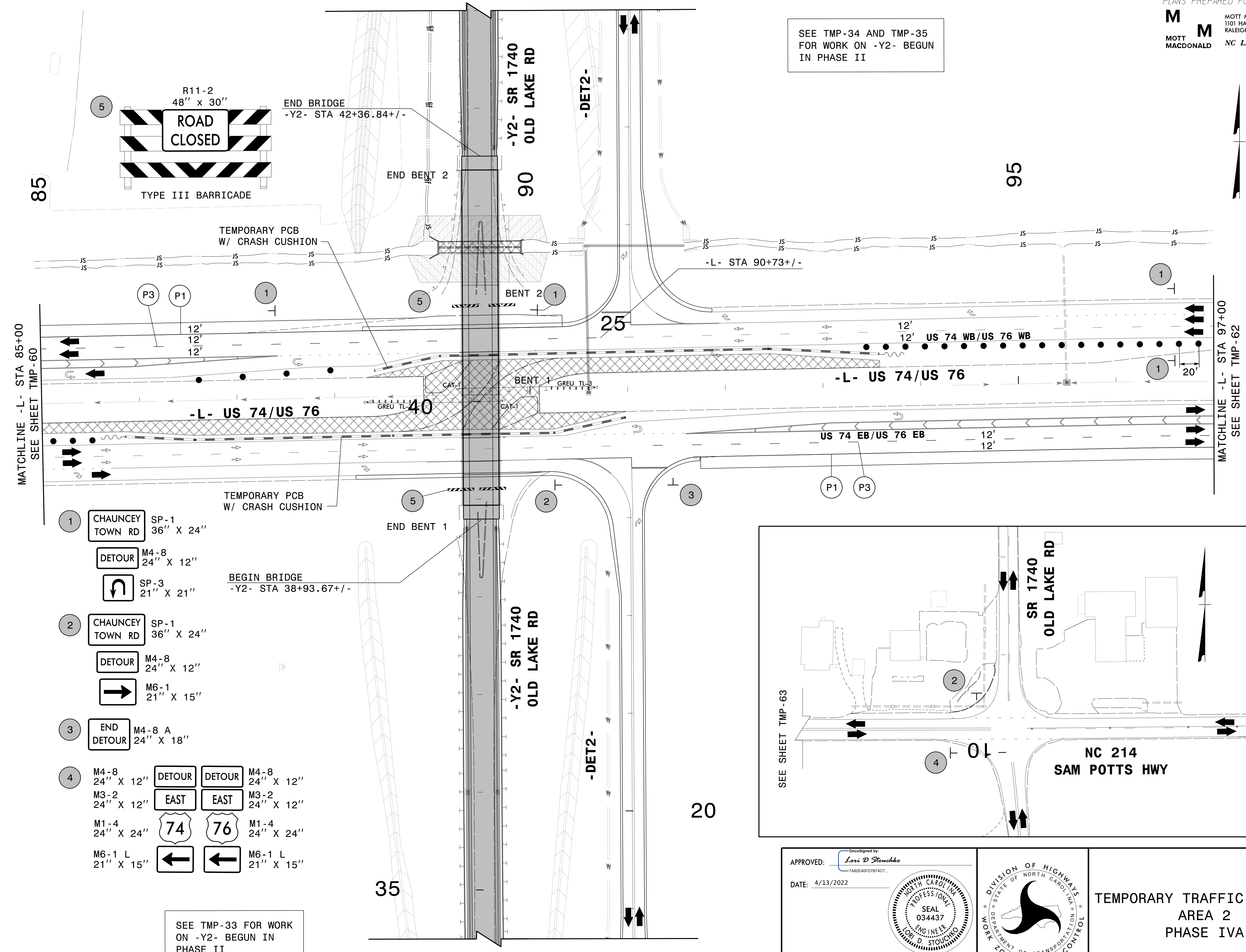

- 1 CHAUNCEY TOWN RD SP-1 36" X 24"
- DETOUR M4-8 24" X 12"
- SP-3 21" X 21"
- 2 CHAUNCEY TOWN RD SP-1 36" X 24"
- DETOUR M4-8 24" X 12"
- M6-1 21" X 15"
- 3 END DETOUR M4-8 A 24" X 18"
- 4 M4-8 24" X 12" DETOUR DETOUR M4-8 24" X 12"
- M3-2 24" X 12" EAST EAST M3-2 24" X 12"
- M1-4 24" X 24" 74 76 M1-4 24" X 24"
- M6-1 L 21" X 15" ← ← M6-1 L 21" X 15"

SEE TMP-33 FOR WORK
ON -Y2- BEGUN IN
PHASE II

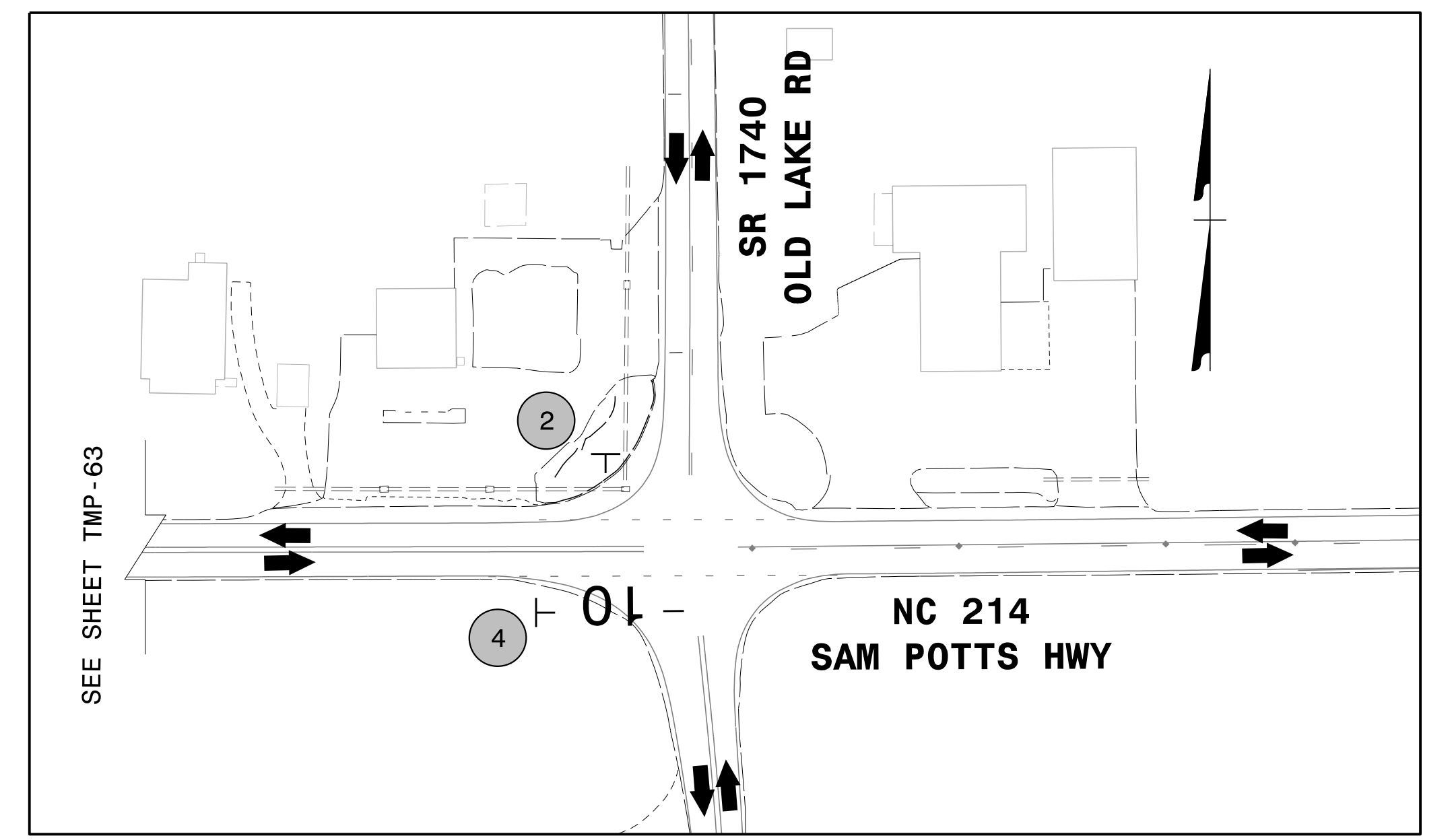

APPROVED: *Lori D Stoucho*
DATE: 4/13/2022

7A82E46FD7874C7

SEAL
034437
ENGINEER
LORI D. STOUCHO

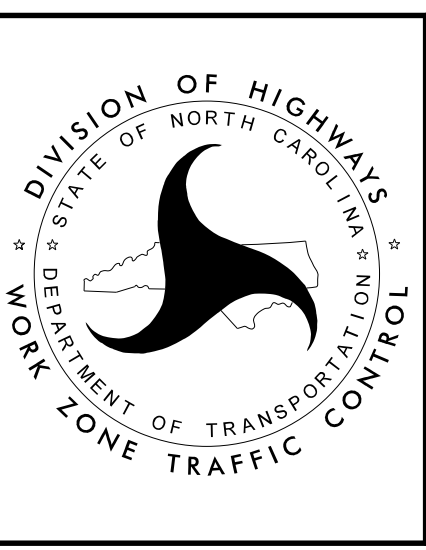

TEMPORARY TRAFFIC CONTROL
AREA 2
PHASE IVA

3/14/2022
G:\501406565_Calyx_R5819_R5820_VR-5819_R-5820\TrafficControl\TrafficControl\TrafficControl\TC_TMP_61_P4A.dgn
User:ST086227

PROJ. REFERENCE NO.	SHEET NO.
R-5819 R-5820	TMP-62

PLANS PREPARED FOR THE NCDOT BY:

M MOTT MACDONALD I & E, LLC
 1101 HAYNES STREET, SUITE 101
 RALEIGH, NC 27604
M NC LICENSE NO. F-0669

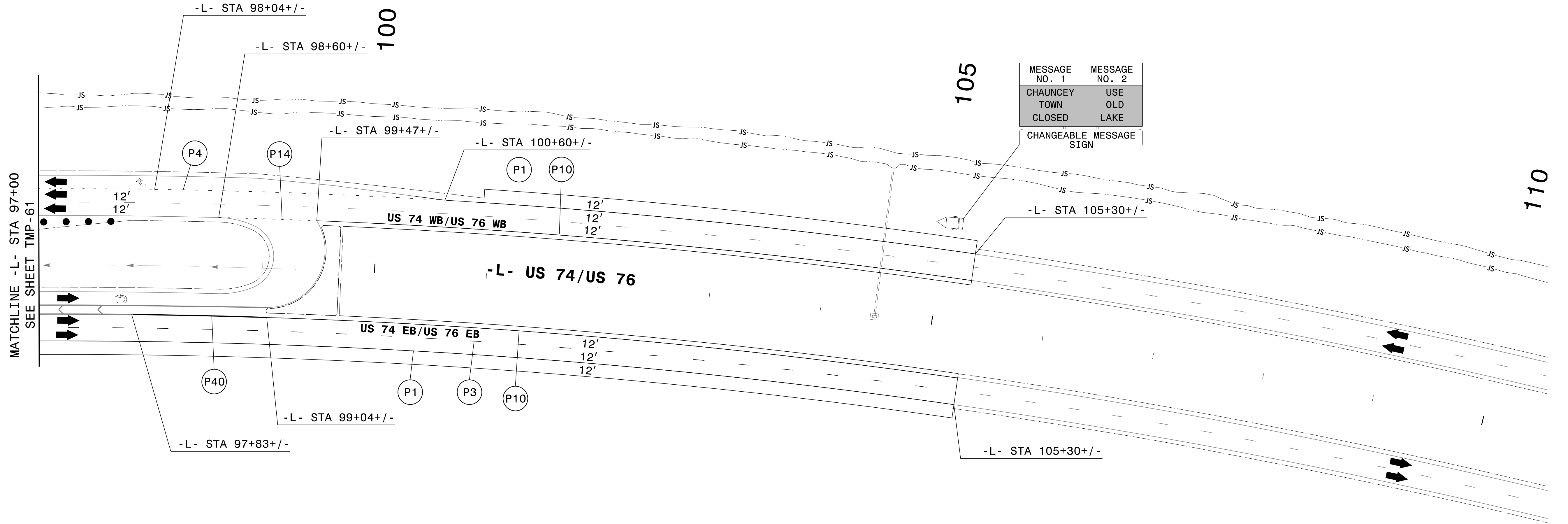

3/14/2022
 G:\501406565_Calyx_R-5820-VR-5819-R-5820-TrafficControl\TrafficControl\CPNR-5819-R-5820-TC-TMP-TMP_62_P4A.dgn
 User:ST086227

APPROVED: *Lori D. Stoucho*
 DATE: 4/13/2022

DOCUMENT NOT CONSIDERED FINAL
 UNLESS ALL SIGNATURES COMPLETED

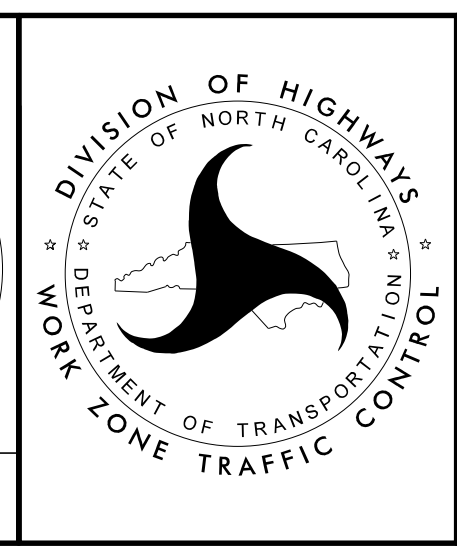

TEMPORARY TRAFFIC CONTROL
 AREA 2
 PHASE IVA

PLANS PREPARED FOR THE NCDOT BY:

M MOTT MACDONALD I & E, LLC
1101 HAYNES STREET, SUITE 101
RALEIGH, NC 27604
M MOTT MACDONALD NC LICENSE NO. F-0669

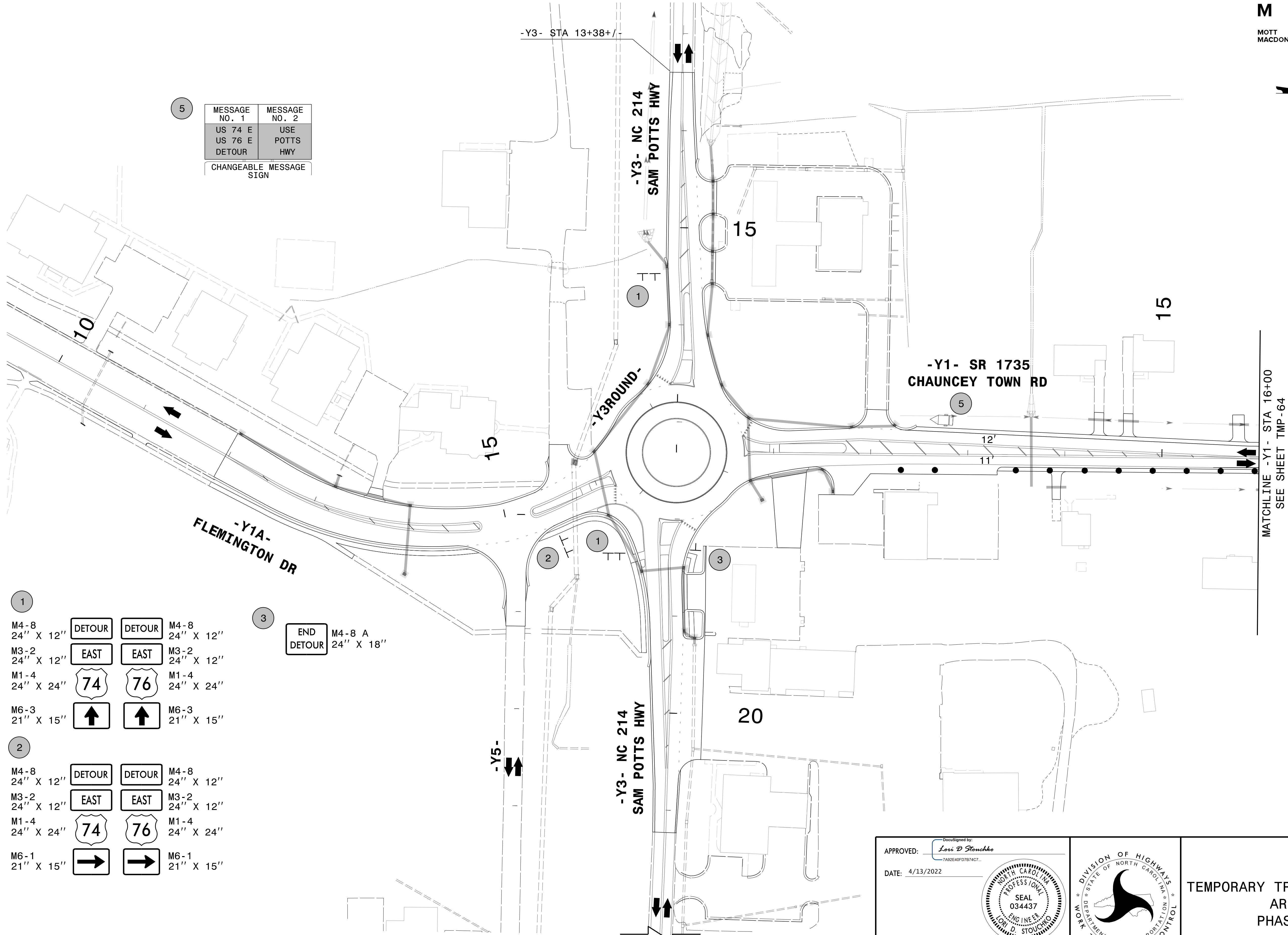

5	MESSAGE NO. 1	MESSAGE NO. 2
	US 74 E	USE
	US 76 E	POTTS HWY
CHANGEABLE MESSAGE SIGN		

- | | | | | | |
|---|-------------------|-------------------|---|---------------|---------------------|
| 1 | M4-8
24" X 12" | M4-8
24" X 12" | 1 | END
DETOUR | M4-8 A
24" X 18" |
| | M3-2
24" X 12" | M3-2
24" X 12" | 2 | | |
| | M1-4
24" X 24" | M1-4
24" X 24" | 3 | | |
| | M6-3
21" X 15" | M6-3
21" X 15" | | | |
-
- | | | | | | |
|---|-------------------|-------------------|--|--|--|
| 2 | M4-8
24" X 12" | M4-8
24" X 12" | | | |
| | M3-2
24" X 12" | M3-2
24" X 12" | | | |
| | M1-4
24" X 24" | M1-4
24" X 24" | | | |
| | M6-1
21" X 15" | M6-1
21" X 15" | | | |

MATCHLINE -Y1- STA 16+00
SEE SHEET TMP-64

SEE SHEET TMP-61

APPROVED: 
DATE: 4/13/2022

7402E40FD7874C7

SEAL
034437
ENGINEER
LOU D. STOUCHO

**DOCUMENT NOT CONSIDERED FINAL
UNLESS ALL SIGNATURES COMPLETED**



TEMPORARY TRAFFIC CONTROL
AREA 2
PHASE IVA

4/13/2022
G:\501406565_Calyx_R5819_R5820\TrafficControl\TrafficControl\NCP\NCP-R-5819_R-5820_TC_TMP_63_P4A.dgn
User:ST086227

PROJ. REFERENCE NO.	SHEET NO.
R-5819 R-5820	TMP-64

PLANS PREPARED FOR THE NCDOT BY:

M MOTT MACDONALD I & E, LLC
 1101 HAYNES STREET, SUITE 101
 RALEIGH, NC 27604
M MOTT MACDONALD
 NC LICENSE NO. F-0669

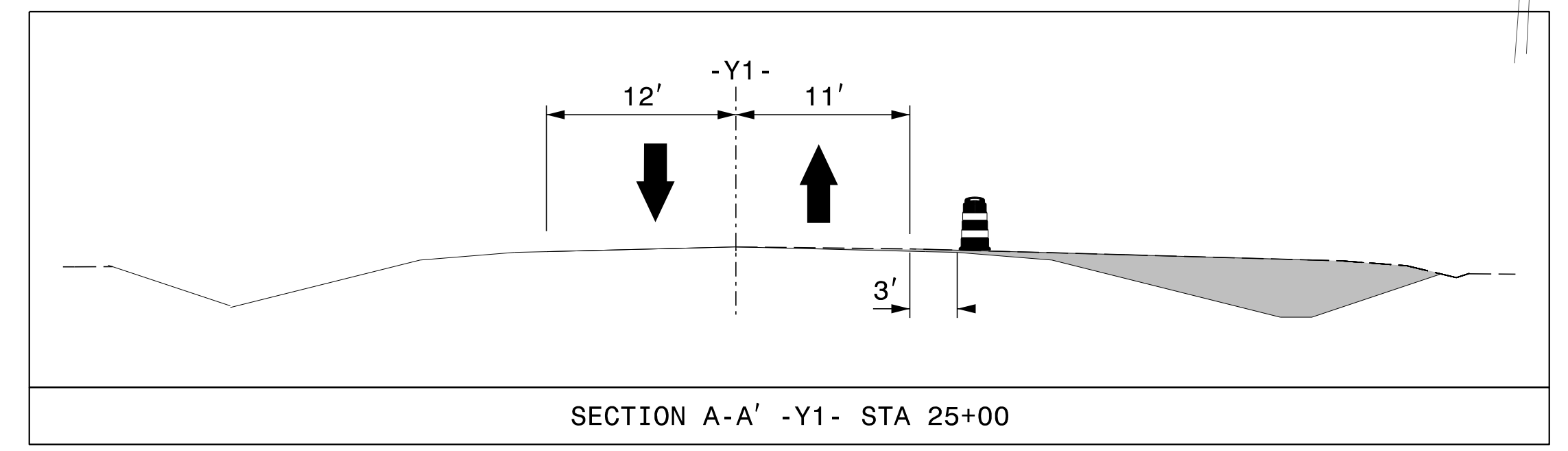
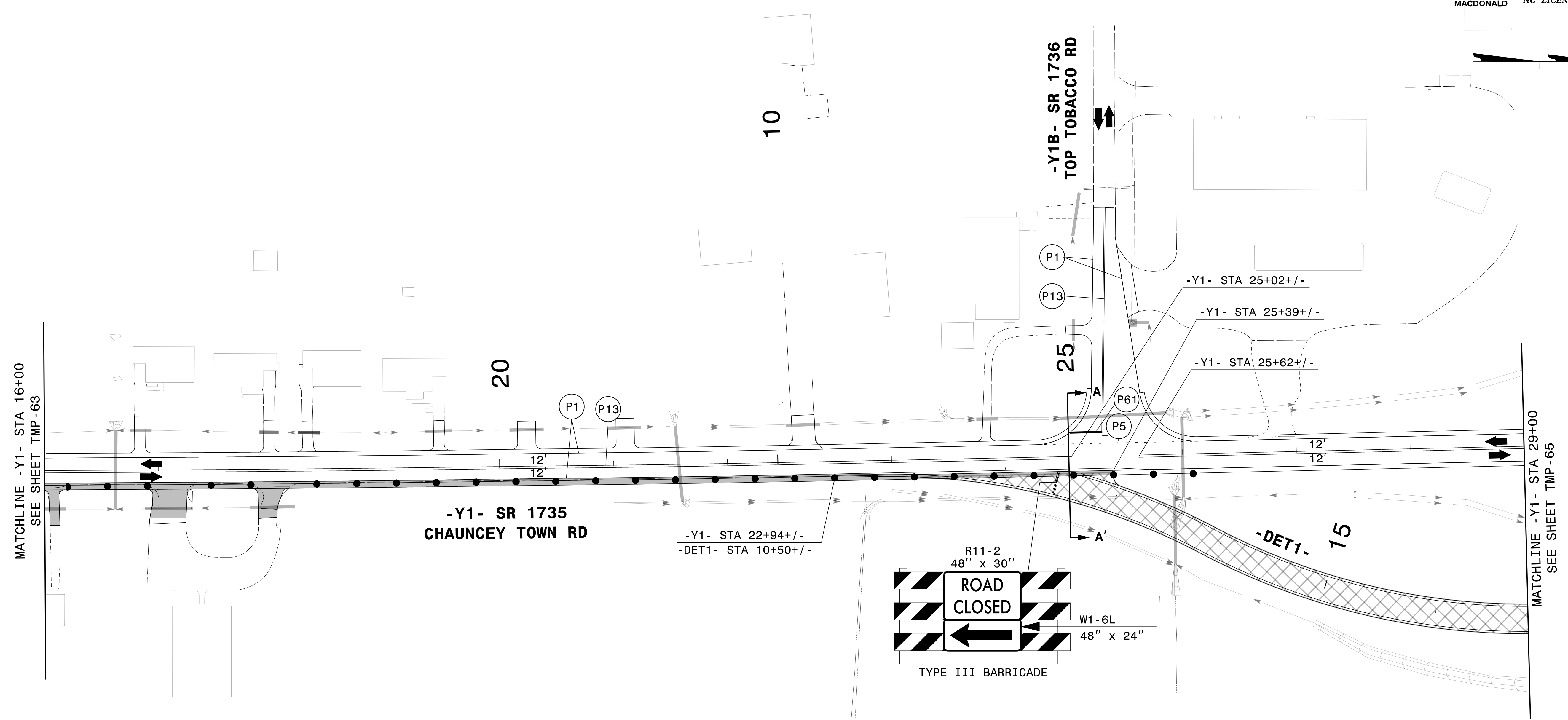

3/14/2022
 G:\501406565_Calyx_R5819_R5820\TrafficControl\CPNR-5819_R-5820_TC_TMP_64_P4A.dgn
 User:ST086227

APPROVED: *Lori D. Stoucho*
7A92E40FD7874C7...

DATE: 4/13/2022

**DOCUMENT NOT CONSIDERED FINAL
 UNLESS ALL SIGNATURES COMPLETED**

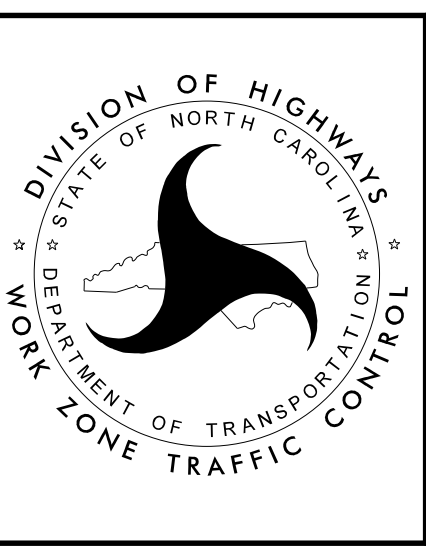

**TEMPORARY TRAFFIC CONTROL
 AREA 2
 PHASE IVA**

PROJ. REFERENCE NO.	SHEET NO.
R-5819 R-5820	TMP-66

PLANS PREPARED FOR THE NCDOT BY:

M MOTT MACDONALD I & E, LLC
 1101 HAYNES STREET, SUITE 101
 RALEIGH, NC 27604
M MOTT MACDONALD
 NC LICENSE NO. F-0669

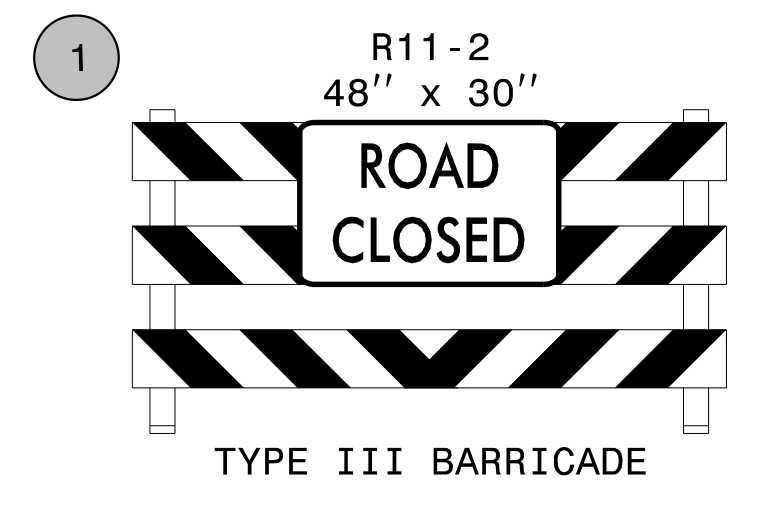
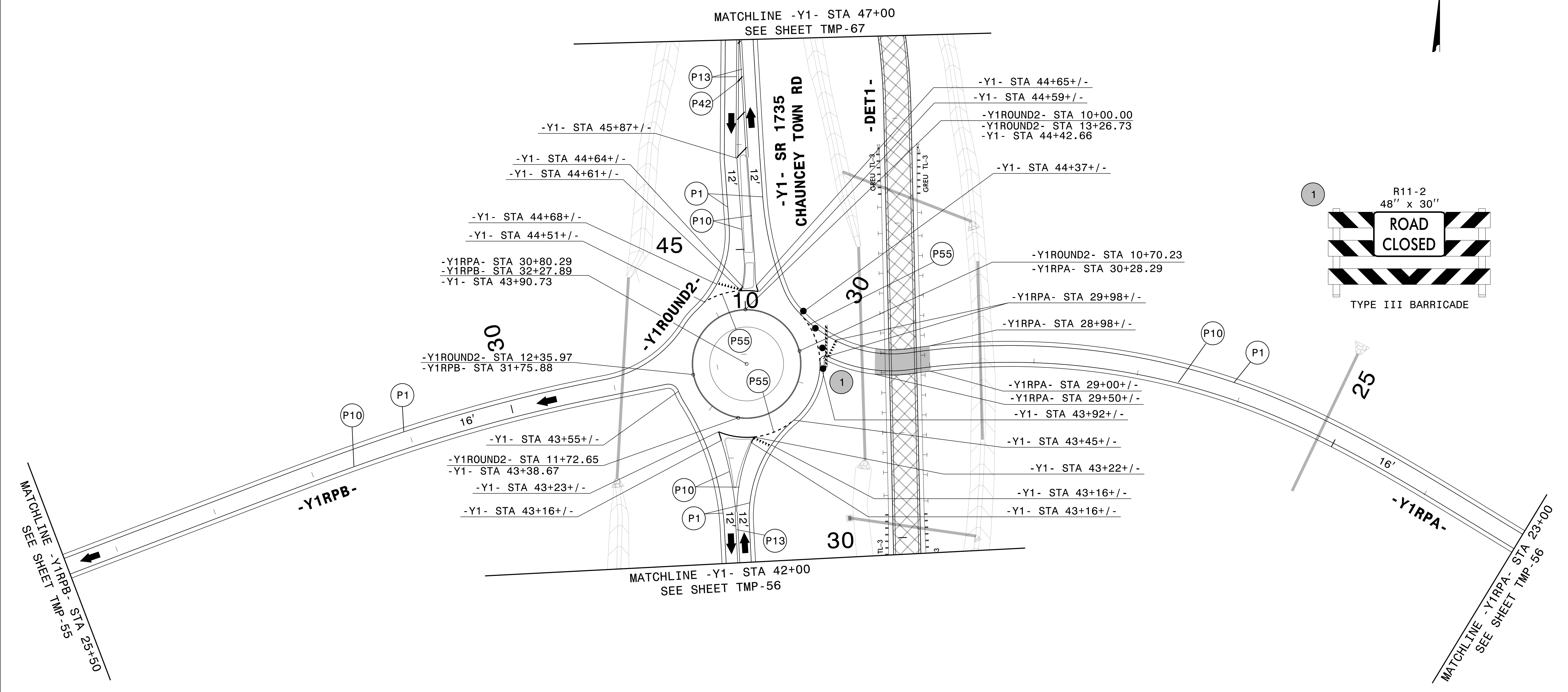
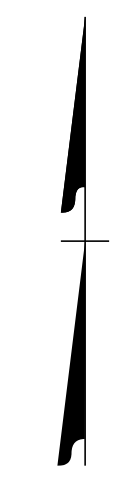

3/14/2022
 G:\501406565_Calyx_R5819_R5820\TrafficControl\TrafficControl\CP\N\R-5819_R-5820\TC-TMP_66_P4A.dgn
 User:ST086227

APPROVED: *Lori D Stoucho*
 DATE: 4/13/2022

**DOCUMENT NOT CONSIDERED FINAL
 UNLESS ALL SIGNATURES COMPLETED**

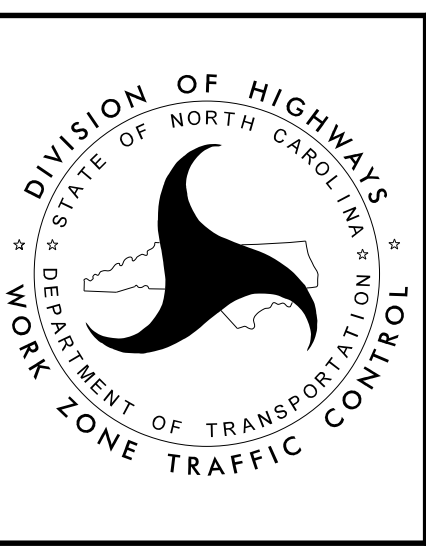

**TEMPORARY TRAFFIC CONTROL
 AREA 2
 PHASE IVA**

PLANS PREPARED FOR THE NCDOT BY:

M MOTT MACDONALD I & E, LLC
 1101 HAYNES STREET, SUITE 101
 RALEIGH, NC 27604
M MOTT MACDONALD
 NC LICENSE NO. F-0669

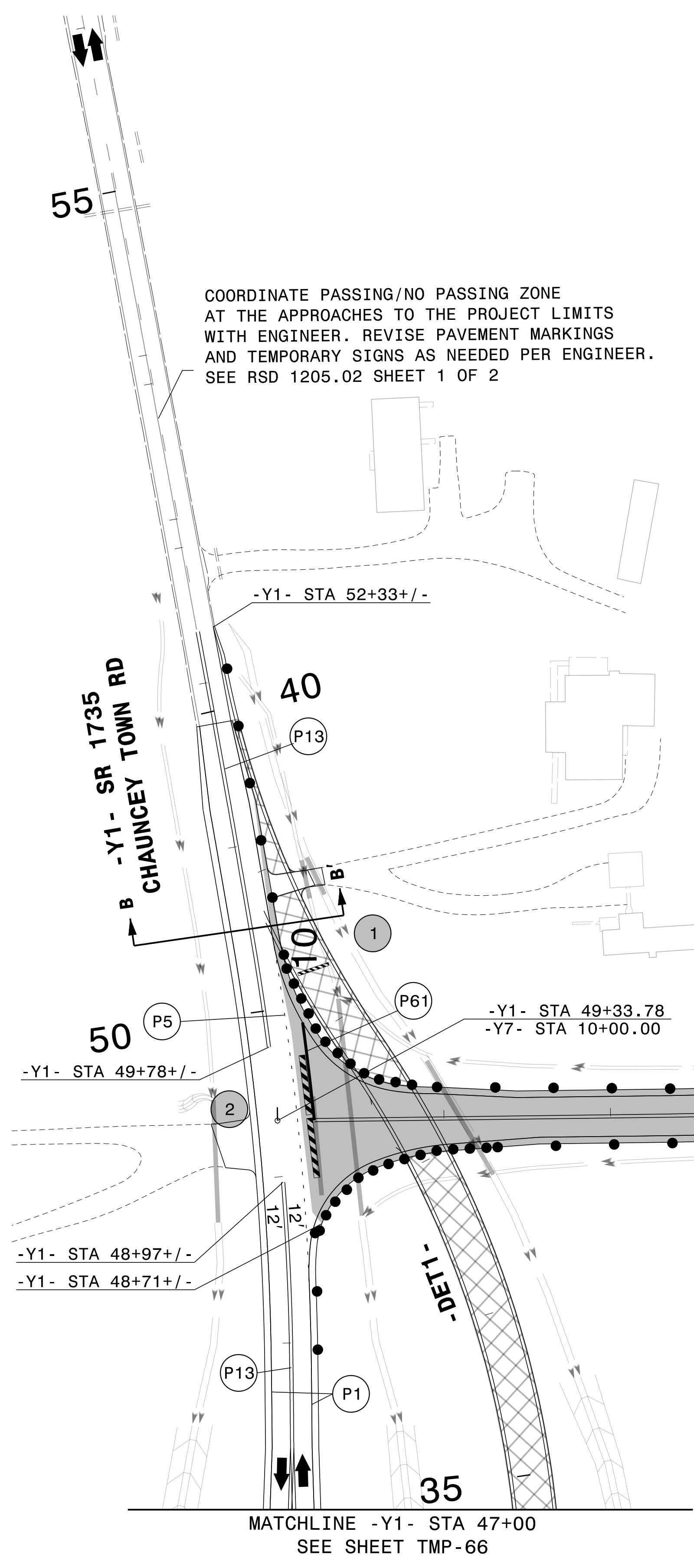
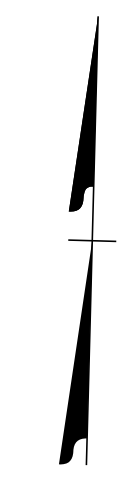

COORDINATE PASSING/NO PASSING ZONE
 AT THE APPROACHES TO THE PROJECT LIMITS
 WITH ENGINEER. REVISE PAVEMENT MARKINGS
 AND TEMPORARY SIGNS AS NEEDED PER ENGINEER.
 SEE RSD 1205.02 SHEET 1 OF 2

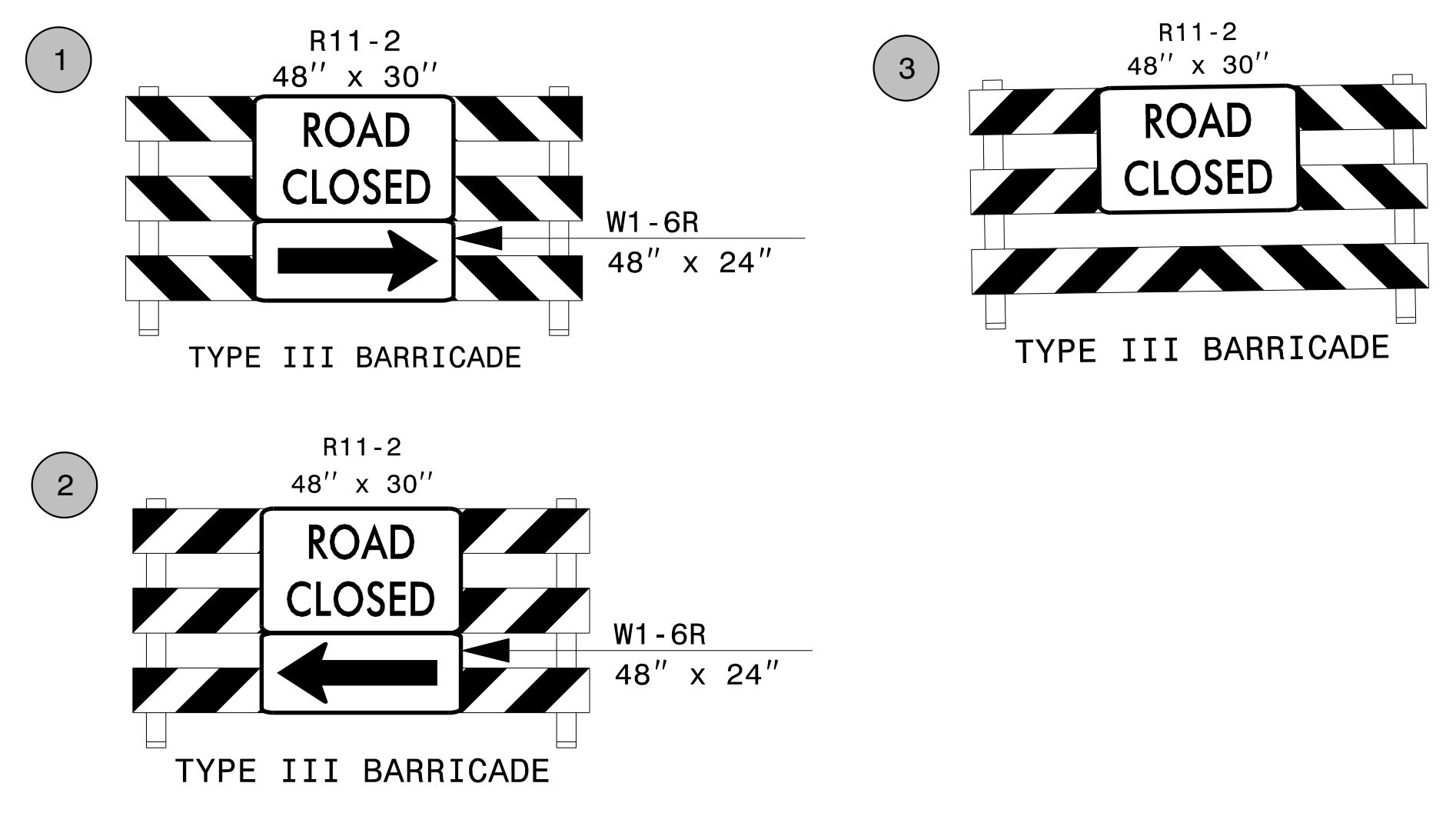
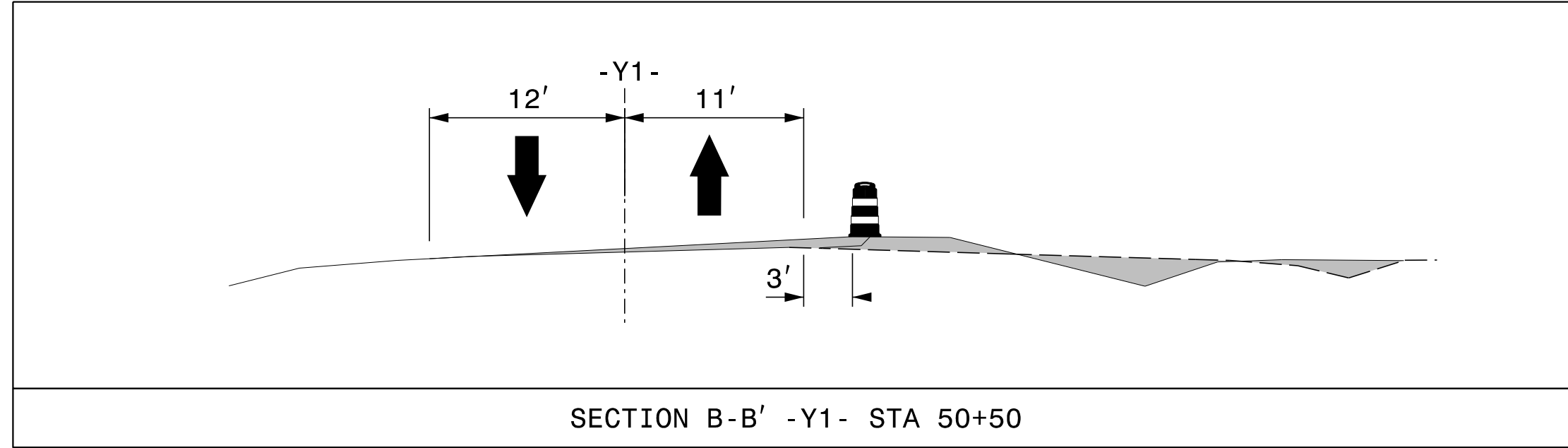

4/13/2022
 G:\501406565_Calyx_R-5820\TrafficControl\TrafficControl\TC-TMP-TMP_67_P4A.dgn
 User:ST086227

APPROVED: *Lori D. Stouchko*
 DATE: 4/13/2022

**DOCUMENT NOT CONSIDERED FINAL
 UNLESS ALL SIGNATURES COMPLETED**

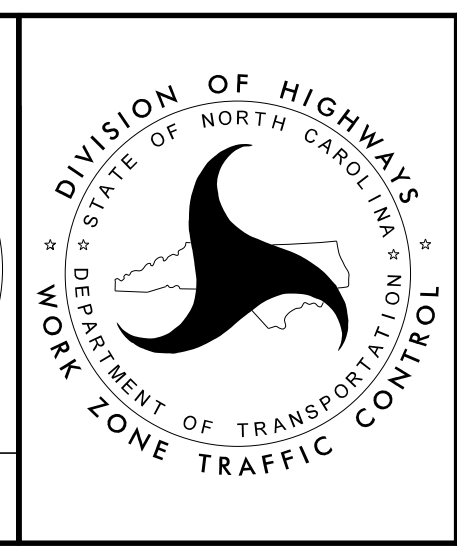

TEMPORARY TRAFFIC CONTROL
 AREA 2
 PHASE IVA

PROJ. REFERENCE NO.	SHEET NO.
R-5819 R-5820	TMP-68

PLANS PREPARED FOR THE NCDOT BY:

M MOTT MACDONALD I & E, LLC
 1101 HAYNES STREET, SUITE 101
 RALEIGH, NC 27604
M NC LICENSE NO. F-0669

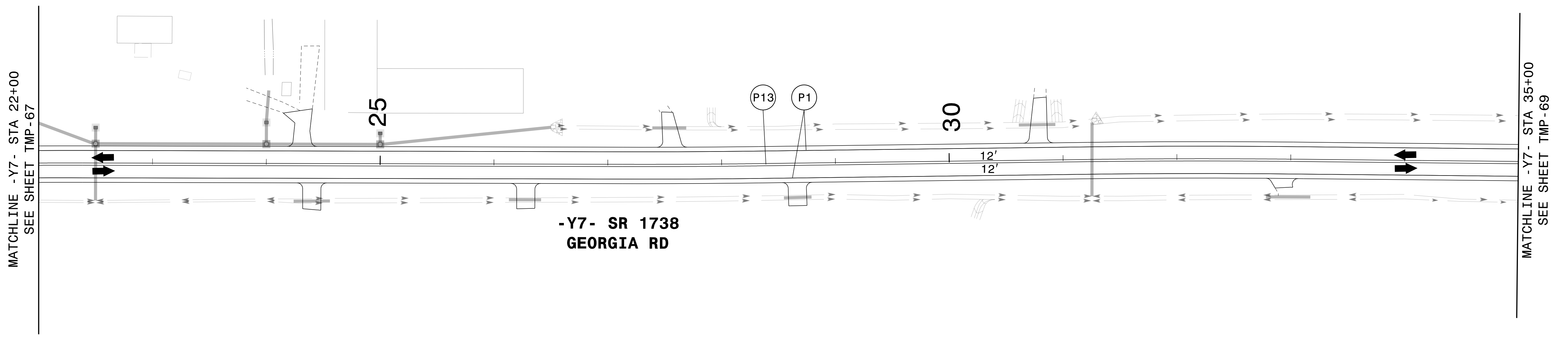

4/13/2022
 G:\501406565_Calyx_R5819_R5820\TrafficControl\TrafficControl\CPNR-5819_R-5820_TC-TMP-TMP_P4A.dgn
 User:ST086227

APPROVED: *Lori D Stoucho*
DocuSigned by:
Lori D Stoucho
7A92E40FD7874C7...

DATE: 4/13/2022

**DOCUMENT NOT CONSIDERED FINAL
UNLESS ALL SIGNATURES COMPLETED**

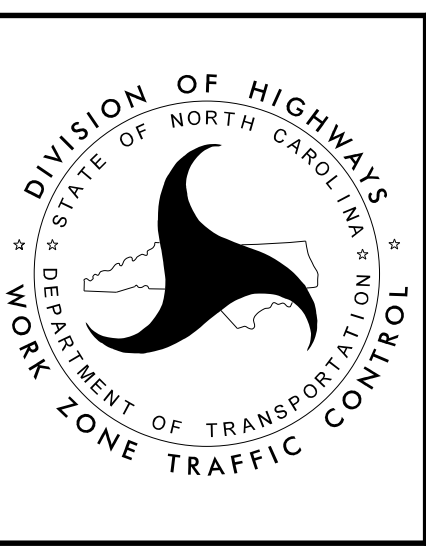

**TEMPORARY TRAFFIC CONTROL
 AREA 2
 PHASE IVA**

PROJ. REFERENCE NO.	SHEET NO.
R-5819 R-5820	TMP-69

PLANS PREPARED FOR THE NCDOT BY:

M MOTT MACDONALD I & E, LLC
 1101 HAYNES STREET, SUITE 101
 RALEIGH, NC 27604

M MOTT MACDONALD
 NC LICENSE NO. F-0669

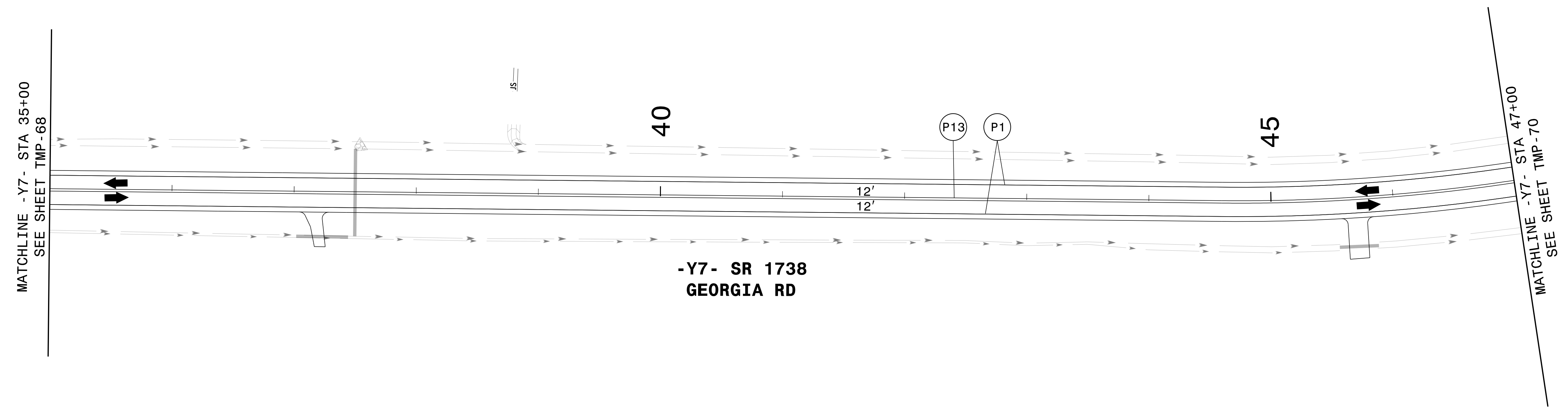

3/14/2022
 G:\501406565_Calyx_R5819_R5820\TrafficControl\TrafficControl\TCP\N\CP\N\R-5819_R-5820_TC_TMP_P4A.dgn
 User:ST086227

APPROVED: *Lori D Stoucho*
DocuSigned by:
Lori D Stoucho
7A92E46FD7874C7...

DATE: 4/13/2022

**DOCUMENT NOT CONSIDERED FINAL
UNLESS ALL SIGNATURES COMPLETED**

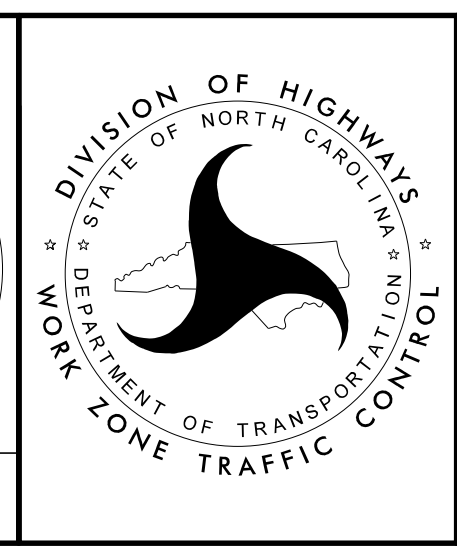

**TEMPORARY TRAFFIC CONTROL
AREA 2
PHASE IVA**

PROJ. REFERENCE NO.	SHEET NO.
R-5819 R-5820	TMP-70

PLANS PREPARED FOR THE NCDOT BY:

M MOTT MACDONALD I & E, LLC
 1101 HAYNES STREET, SUITE 101
 RALEIGH, NC 27604

M MOTT MACDONALD
 NC LICENSE NO. F-0669

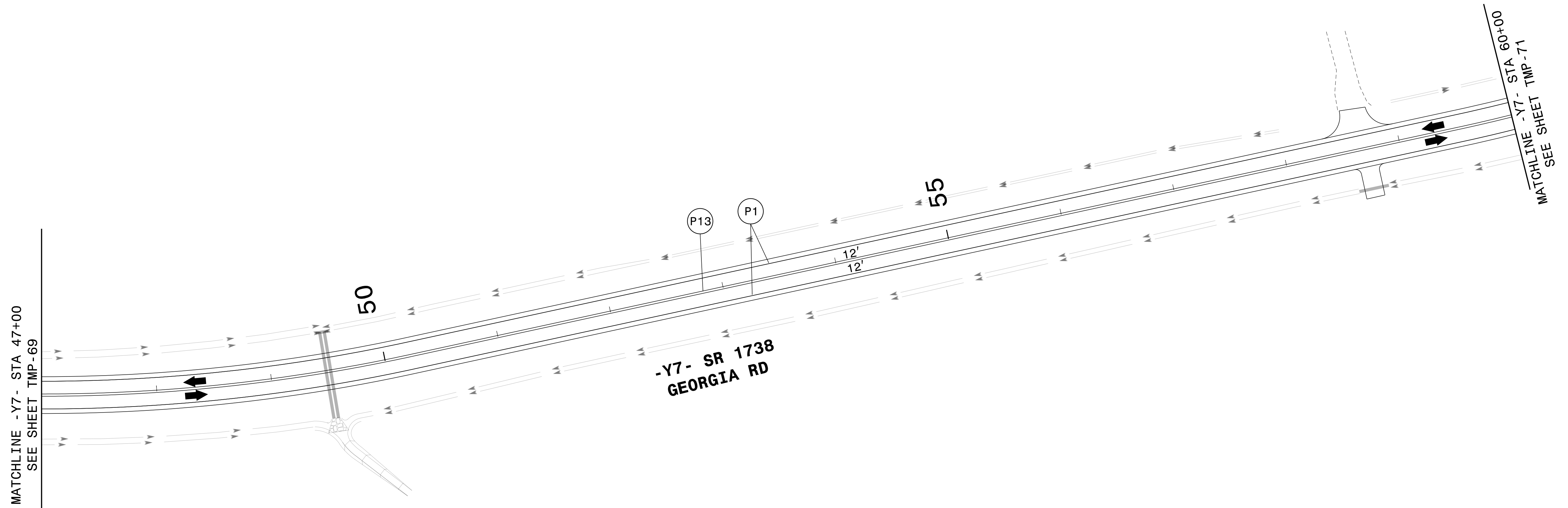
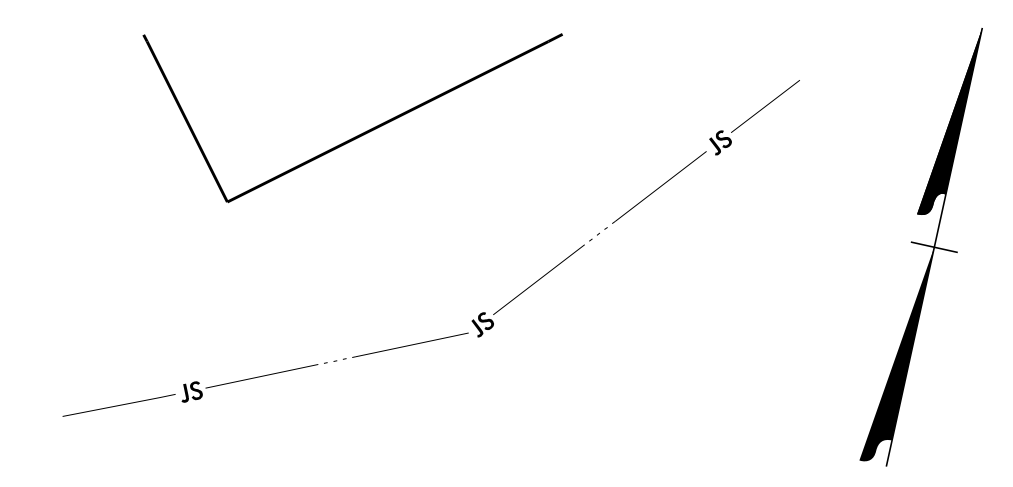

3/14/2022
 G:\501406565_Calyx_R5819_R5820\TrafficControl\TrafficControl\CPNR-5819_R-5820_TC-TMP-TMP_70_P4A.dgn
 User:ST086227

APPROVED: *Lori D Stoucho*
DocuSigned by:
Lori D Stoucho
7A92E46FD7874C7...

DATE: 4/13/2022

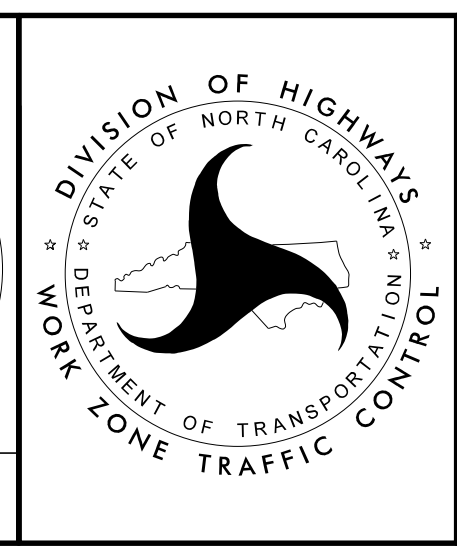

**TEMPORARY TRAFFIC CONTROL
 AREA 2
 PHASE IVA**

**DOCUMENT NOT CONSIDERED FINAL
 UNLESS ALL SIGNATURES COMPLETED**

PROJ. REFERENCE NO.	SHEET NO.
R-5819 R-5820	TMP-71

PLANS PREPARED FOR THE NCDOT BY:
M MOTT MACDONALD I & E, LLC
 1101 HAYNES STREET, SUITE 101
 RALEIGH, NC 27604
M MOTT MACDONALD
 NC LICENSE NO. F-0669

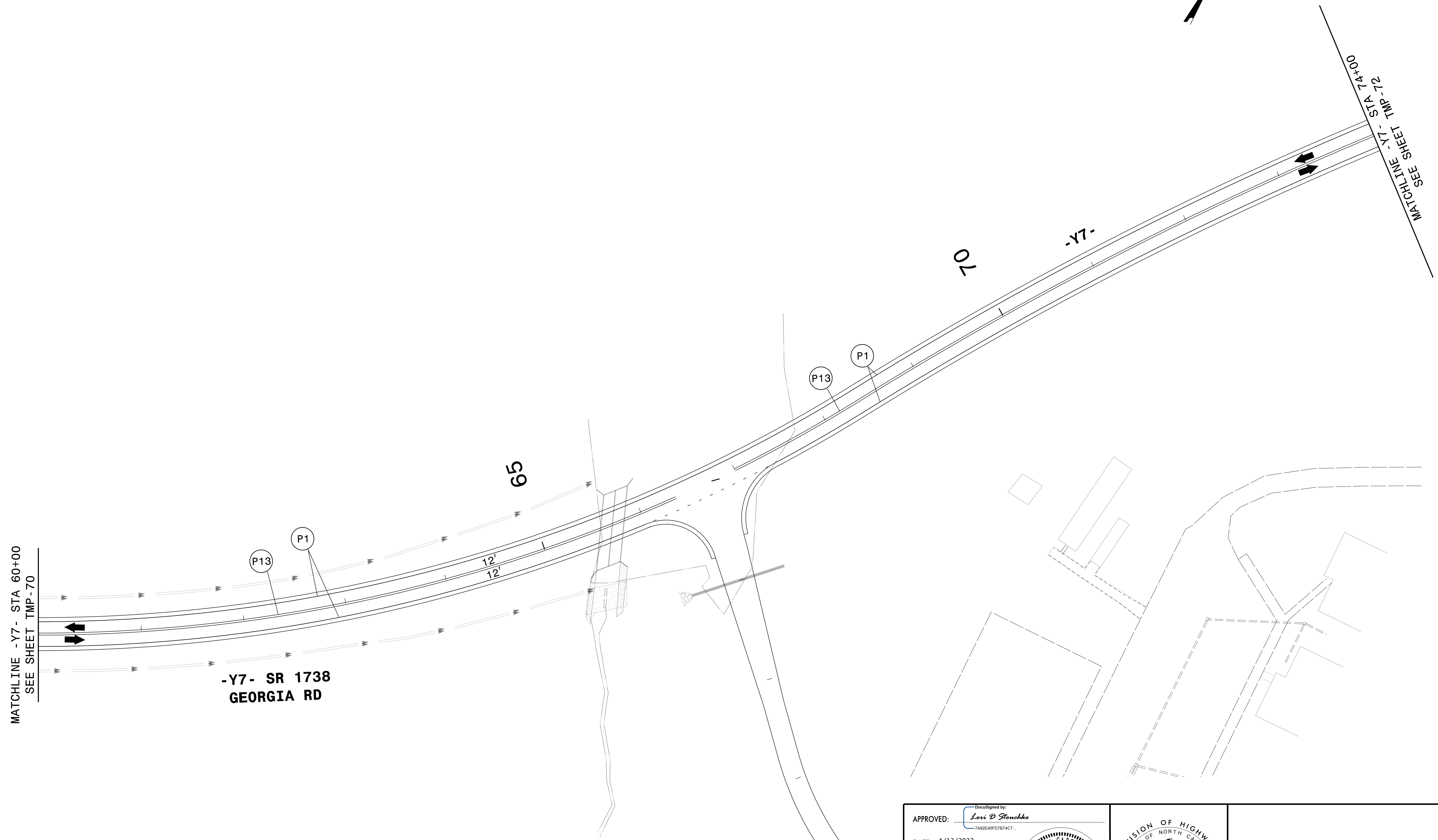
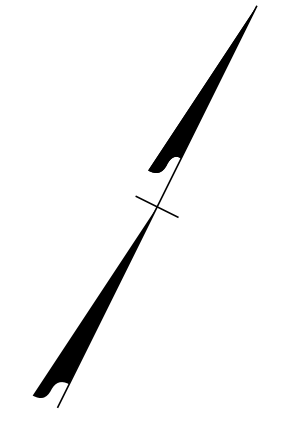

3/14/2022
 G:\501406565_Calyx_R5819_R5820\TrafficControl\TrafficControl\CPNR-5819_R-5820_TC-TMP_TMP-71_P44.dgn
 User:ST086227

APPROVED: *Lori D Stoucho*
DocuSigned by:
Lori D Stoucho
7A92E40FD7874C7...

DATE: 4/13/2022

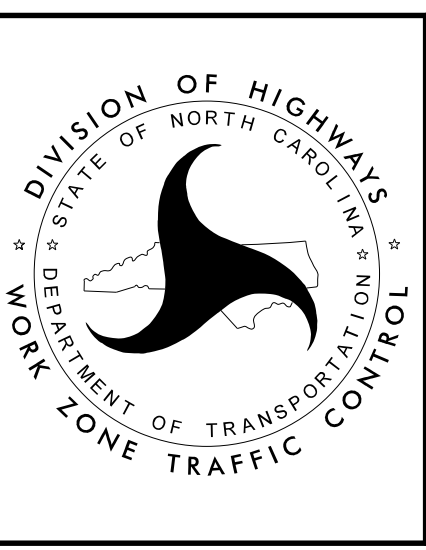

**TEMPORARY TRAFFIC CONTROL
 AREA 2
 PHASE IVA**

**DOCUMENT NOT CONSIDERED FINAL
 UNLESS ALL SIGNATURES COMPLETED**

PLANS PREPARED FOR THE NCDOT BY:
M MOTT MACDONALD I & E, LLC
 1101 HAYNES STREET, SUITE 101
 RALEIGH, NC 27604
M MOTT MACDONALD
 NC LICENSE NO. F-0669

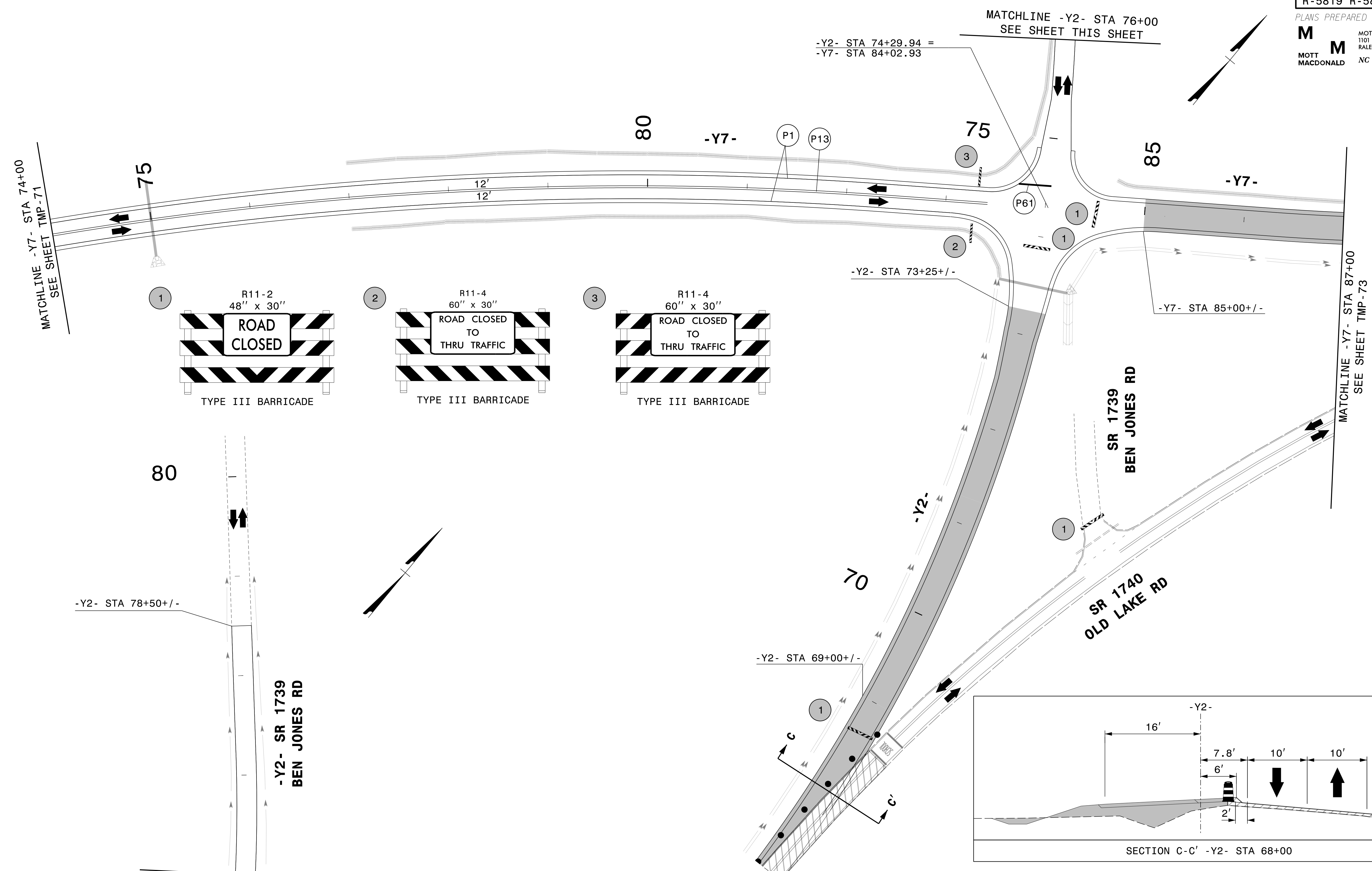

3/14/2022
 G:\501406565_Calyx_R5819_R5820\TrafficControl\CPNR-5819_R-5820_TC_TMP_72_P4A.dgn
 User:ST086227

APPROVED: *Lori D. Stoucho*
 DATE: 4/13/2022

**DOCUMENT NOT CONSIDERED FINAL
UNLESS ALL SIGNATURES COMPLETED**

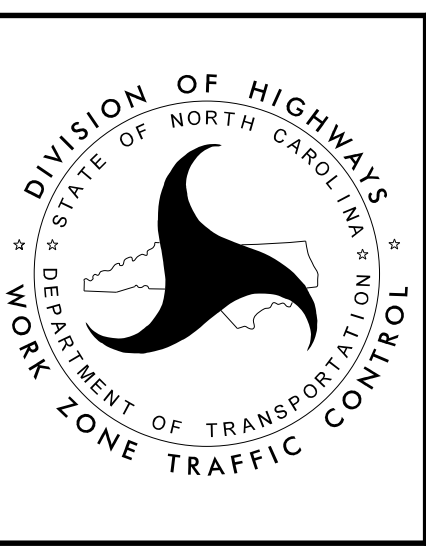

**TEMPORARY TRAFFIC CONTROL
AREA 2
PHASE IVA**

PROJ. REFERENCE NO.	SHEET NO.
R-5819 R-5820	TMP-73

PLANS PREPARED FOR THE NCDOT BY:

M MOTT MACDONALD I & E, LLC
1101 HAYNES STREET, SUITE 101
RALEIGH, NC 27604

M MOTT MACDONALD
NC LICENSE NO. F-0669

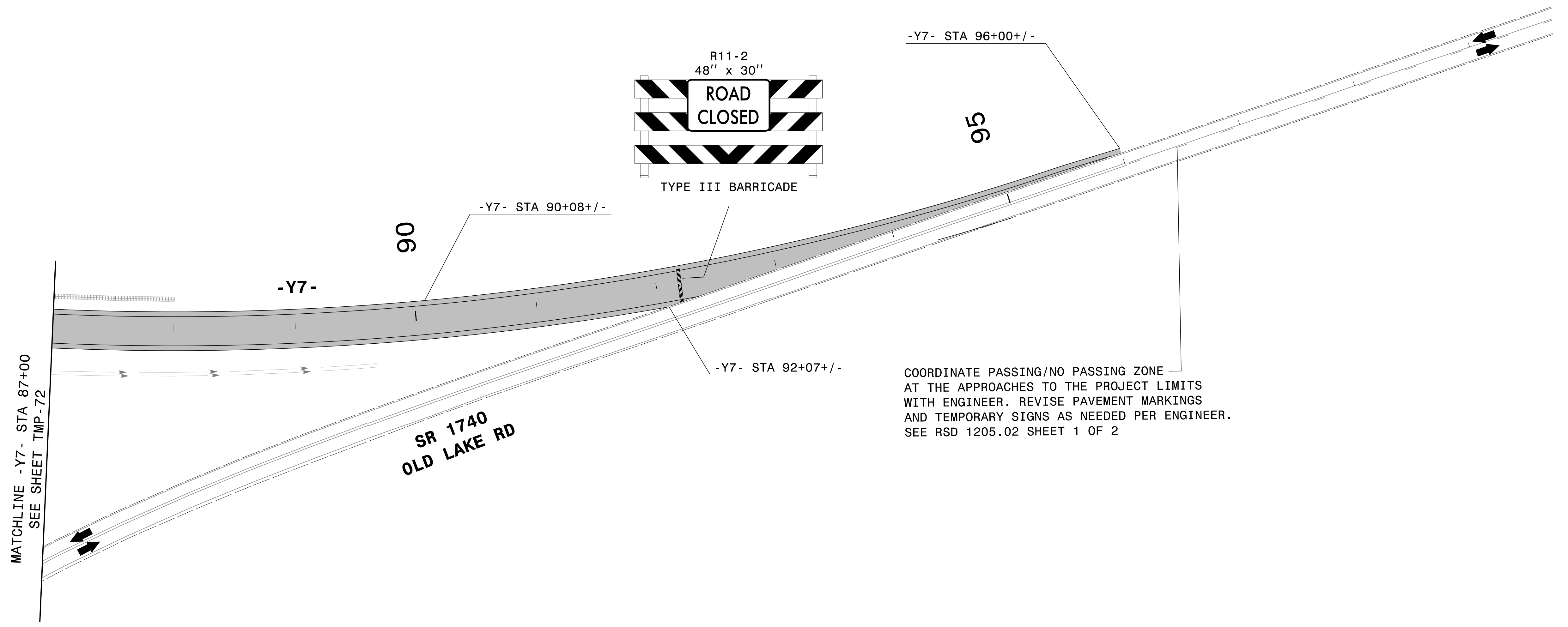
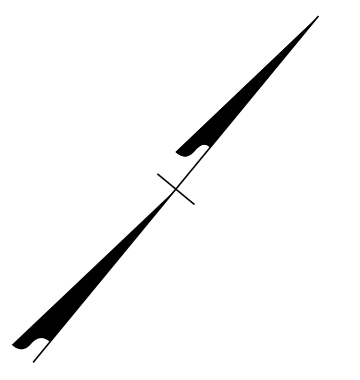

3/14/2022
G:\501406565_Calyx_R5819_R5820\TrafficControl\CPNR-5819_R-5820_TC_TMP_73_P4A.dgn
User:ST086227

APPROVED: *Lori D Stoucho*
DocuSigned by:
Lori D Stoucho
7A92E46FD7874C7...

DATE: 4/13/2022

**DOCUMENT NOT CONSIDERED FINAL
UNLESS ALL SIGNATURES COMPLETED**

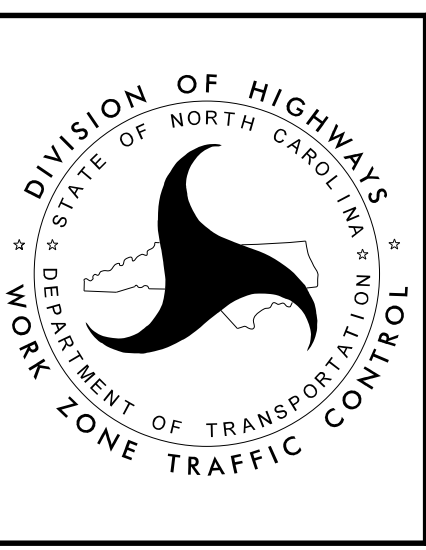

**TEMPORARY TRAFFIC CONTROL
AREA 2
PHASE IVA**

PROJ. REFERENCE NO.	SHEET NO.
R-5819 R-5820	TMP-74

PLANS PREPARED FOR THE NCDOT BY:

M MOTT MACDONALD I & E, LLC
 1101 HAYNES STREET, SUITE 101
 RALEIGH, NC 27604
M MOTT MACDONALD NC LICENSE NO. F-0669

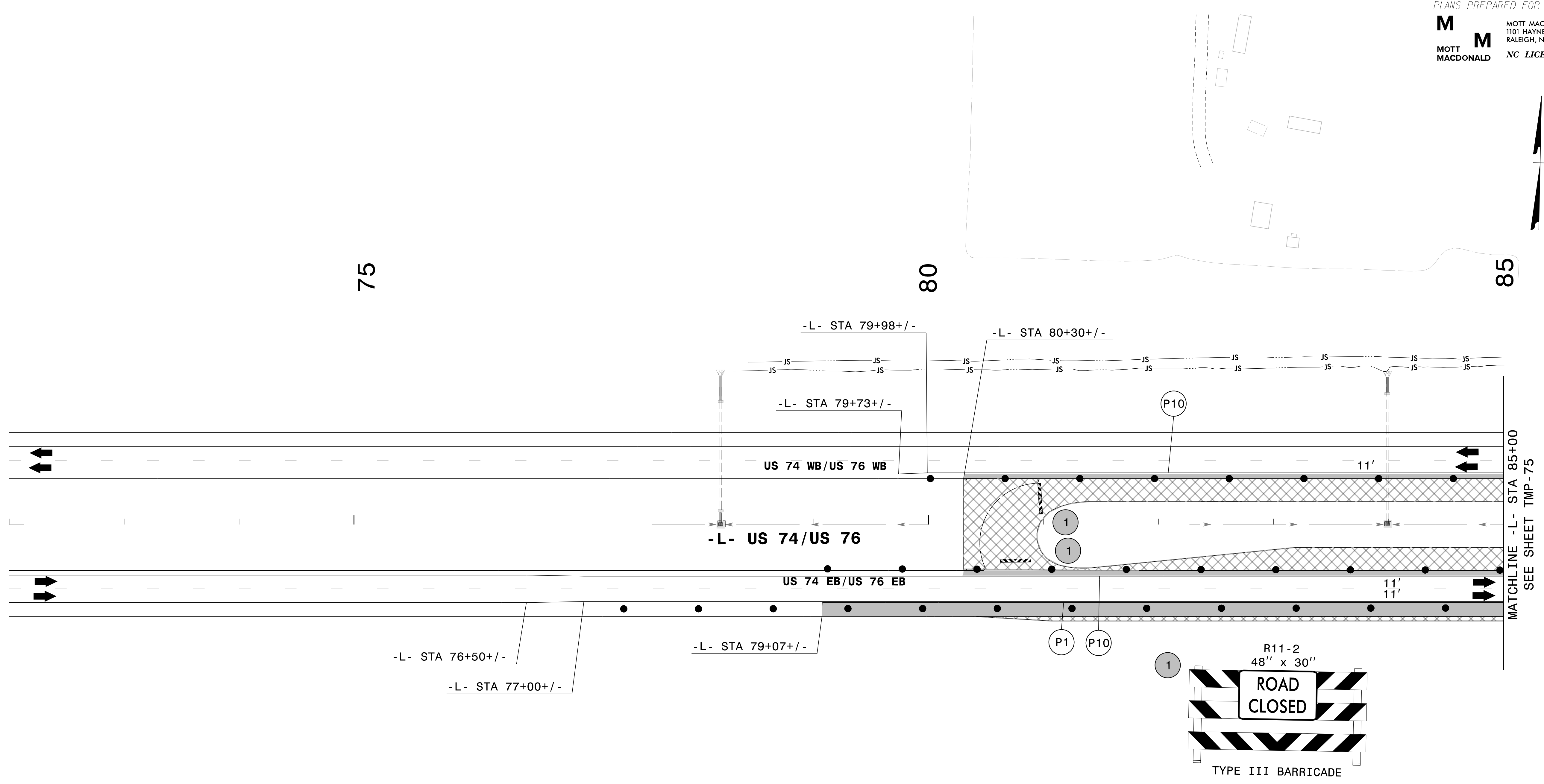

3/14/2022
G:\501406565_Calyx_R5819_R5820\TrafficControl\TrafficControl\TC_TMP_74_P4B.dgn
User:ST086227

APPROVED: *Lori D. Stoucho*
DocuSigned by:
Lori D. Stoucho
7A92E40FD7874C7...

DATE: 4/13/2022

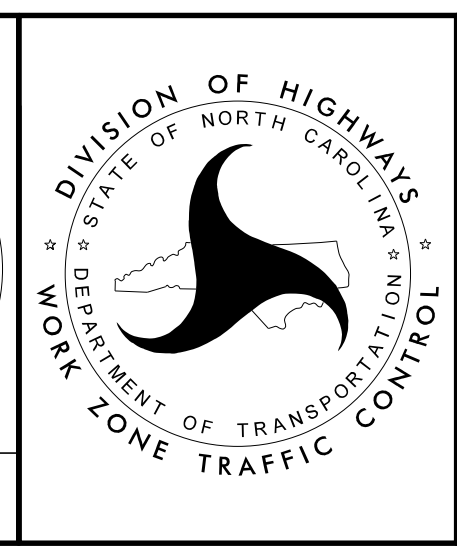

**TEMPORARY TRAFFIC CONTROL
 AREA 2
 PHASE IVB**

**DOCUMENT NOT CONSIDERED FINAL
 UNLESS ALL SIGNATURES COMPLETED**

PROJ. REFERENCE NO.	SHEET NO.
R-5819 R-5820	TMP-75

PLANS PREPARED FOR THE NCDOT BY:
M MOTT MACDONALD I & E, LLC
 1101 HAYNES STREET, SUITE 101
 RALEIGH, NC 27604
M MOTT MACDONALD
 NC LICENSE NO. F-0669

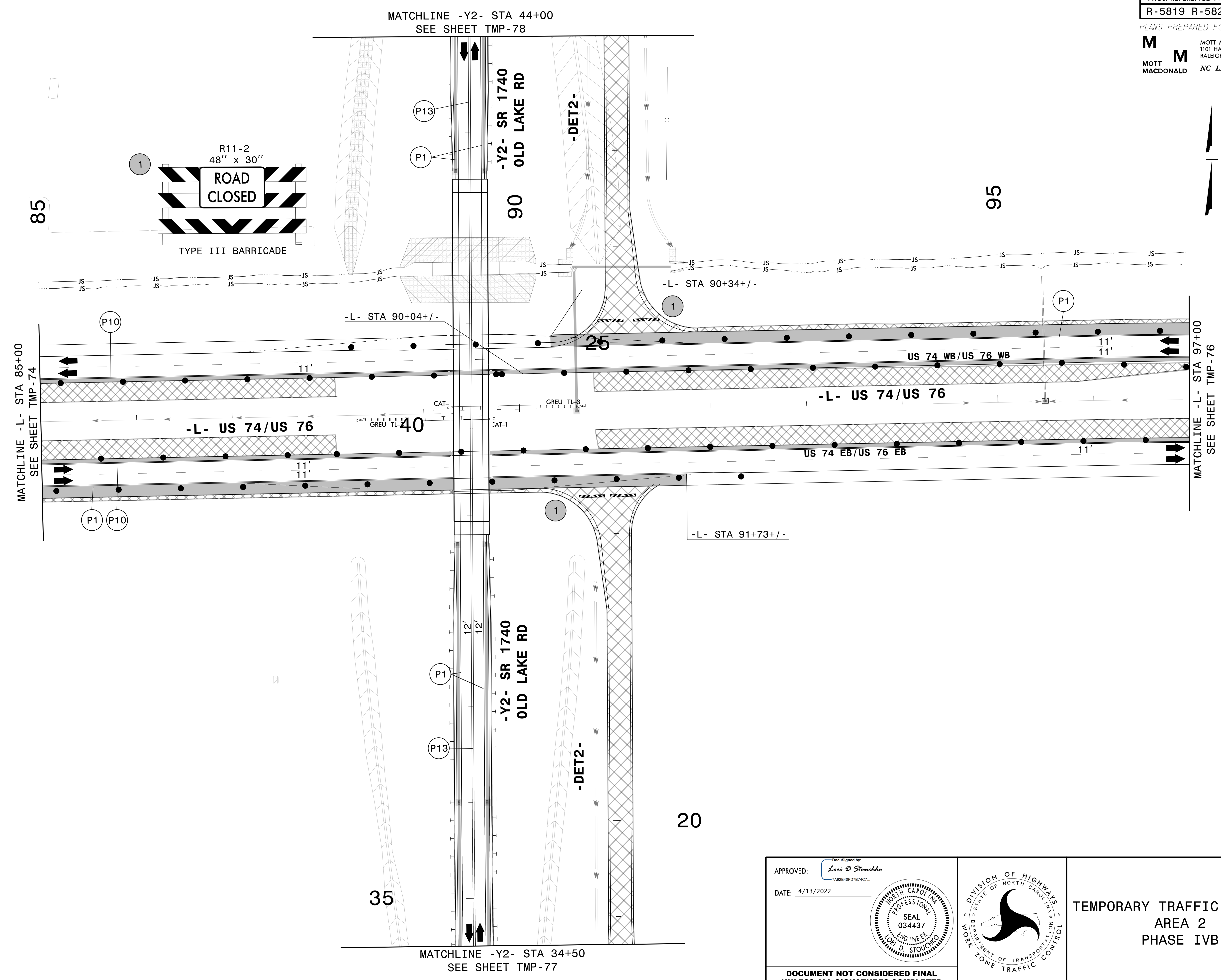
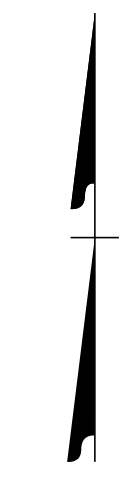

3/14/2022
 G:\50406565_Calyx_R5819_R5820\TrafficControl\CPNR-5819_R-5820_TC_TMP_75_P4B.dgn
 User:ST086227

APPROVED: *Lori D Stoucho*
7A92E46FD7874C7...

DATE: 4/13/2022

**DOCUMENT NOT CONSIDERED FINAL
UNLESS ALL SIGNATURES COMPLETED**

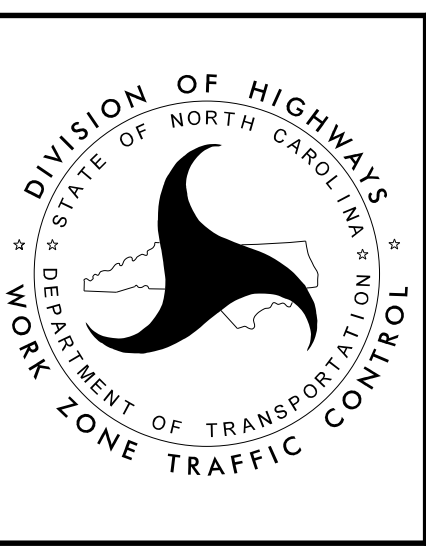

**TEMPORARY TRAFFIC CONTROL
AREA 2
PHASE IVB**

PLANS PREPARED FOR THE NCDOT BY:
M MOTT MACDONALD I & E, LLC
 1101 HAYNES STREET, SUITE 101
 RALEIGH, NC 27604
M MOTT MACDONALD NC LICENSE NO. F-0669

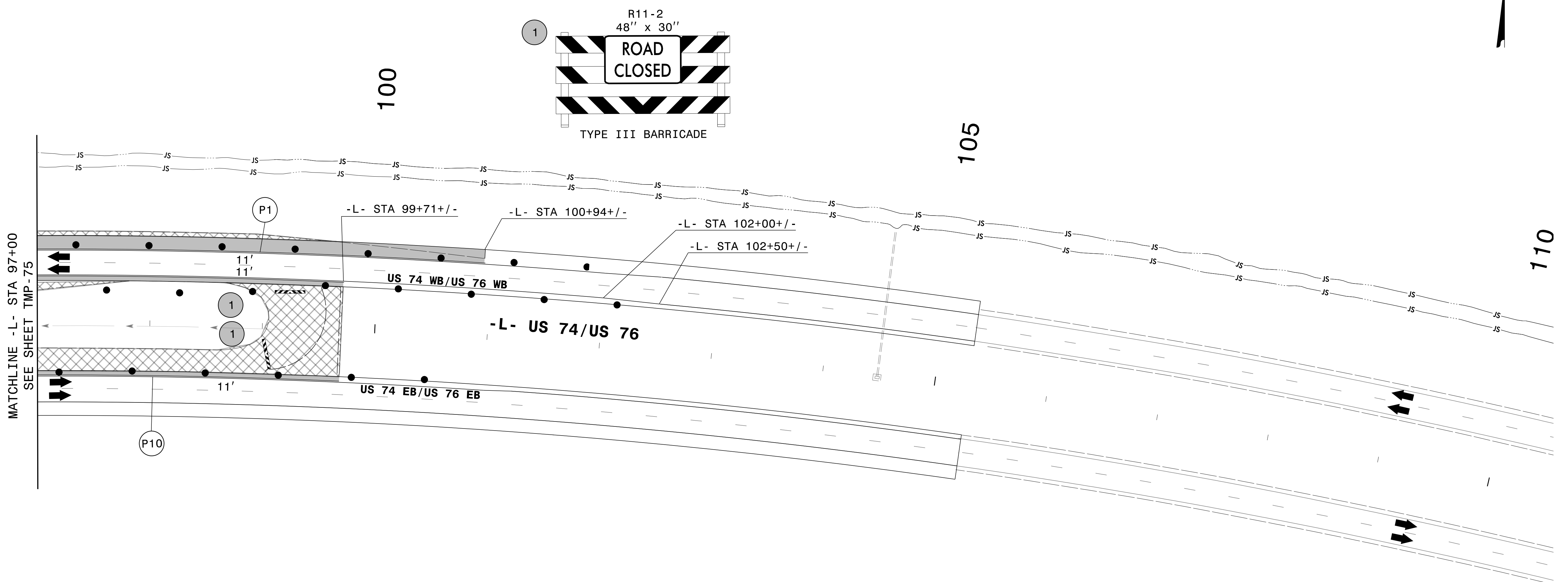
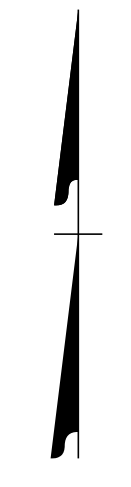

3/14/2022
 G:\501406565_Calyx_R5819_R5820_VR-5819_R-5820\TrafficControl\TC-TMP-76_P4B.dgn
 User:ST08627

APPROVED: <i>Lois D Stoucho</i> DATE: 4/13/2022 		TEMPORARY TRAFFIC CONTROL AREA 2 PHASE IVB
<p style="text-align: center;">DOCUMENT NOT CONSIDERED FINAL UNLESS ALL SIGNATURES COMPLETED</p>		

PLANS PREPARED FOR THE NCDOT BY:

M MOTT MACDONALD I & E, LLC
1101 HAYNES STREET, SUITE 101
RALEIGH, NC 27604

M MOTT MACDONALD
NC LICENSE NO. F-0669

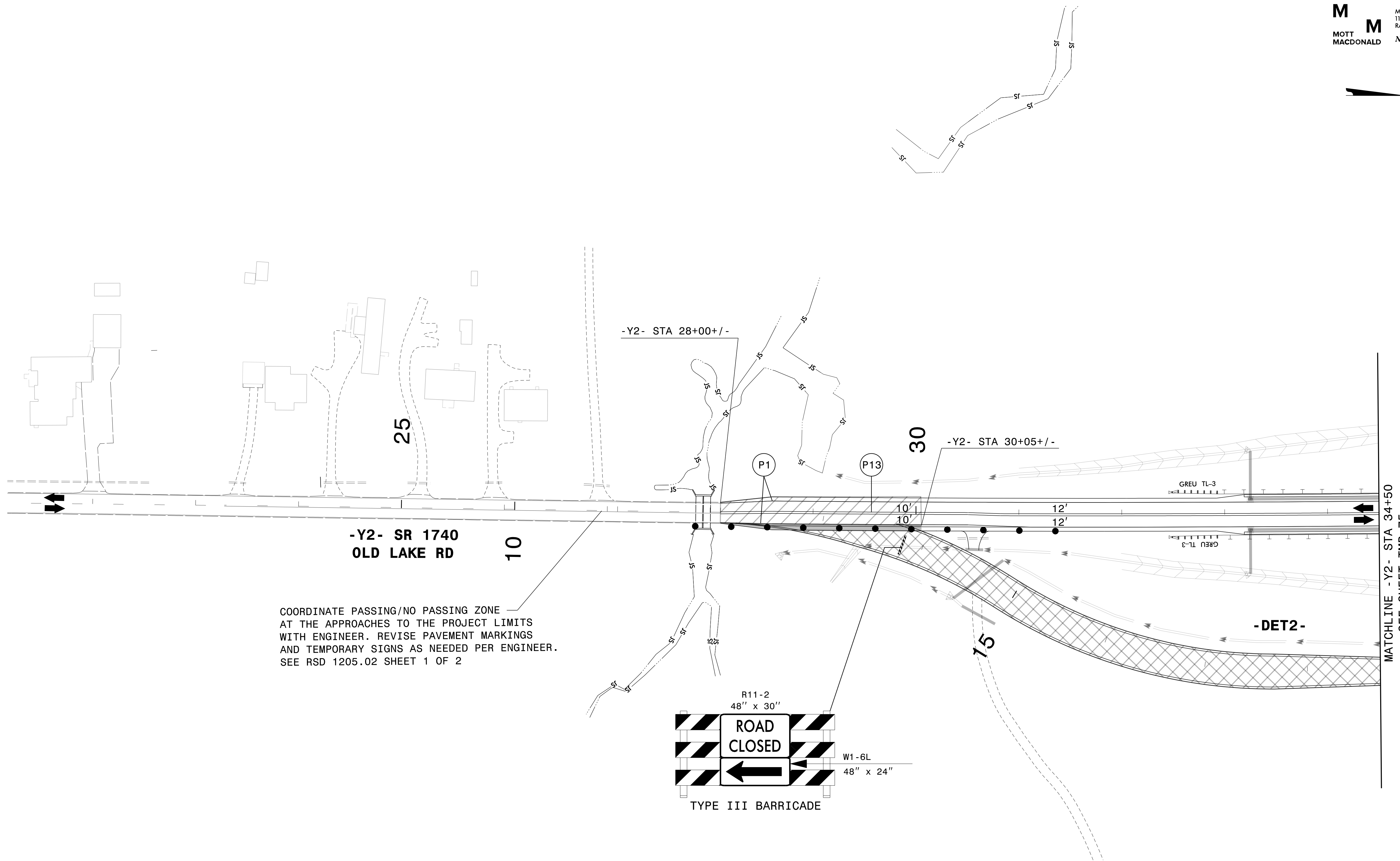
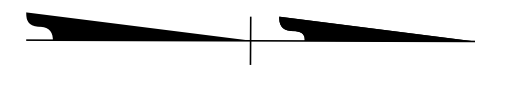

COORDINATE PASSING/NO PASSING ZONE AT THE APPROACHES TO THE PROJECT LIMITS WITH ENGINEER. REVISE PAVEMENT MARKINGS AND TEMPORARY SIGNS AS NEEDED PER ENGINEER. SEE RSD 1205.02 SHEET 1 OF 2

MATCHLINE - Y2- STA 34+50
SEE SHEET TMP-75

3/14/2022
G:\501406565_Calyx_R5819_R5820\TrafficControl\TCP\R-5819_R-5820_TC_TMP_77_P4B.dgn
User:ST086227

APPROVED: *Lori D. Stoucho*
DATE: 4/13/2022

DOCUMENT NOT CONSIDERED FINAL UNLESS ALL SIGNATURES COMPLETED

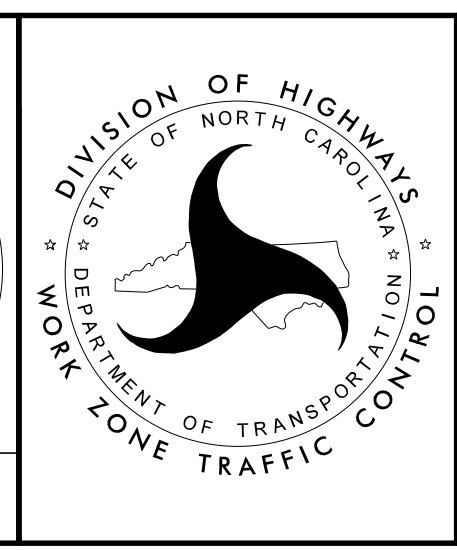

TEMPORARY TRAFFIC CONTROL AREA 2 PHASE IVB

PLANS PREPARED FOR THE NCDOT BY:
M MOTT MACDONALD I & E, LLC
 1101 HAYNES STREET, SUITE 101
 RALEIGH, NC 27604
M MOTT MACDONALD NC LICENSE NO. F-0669

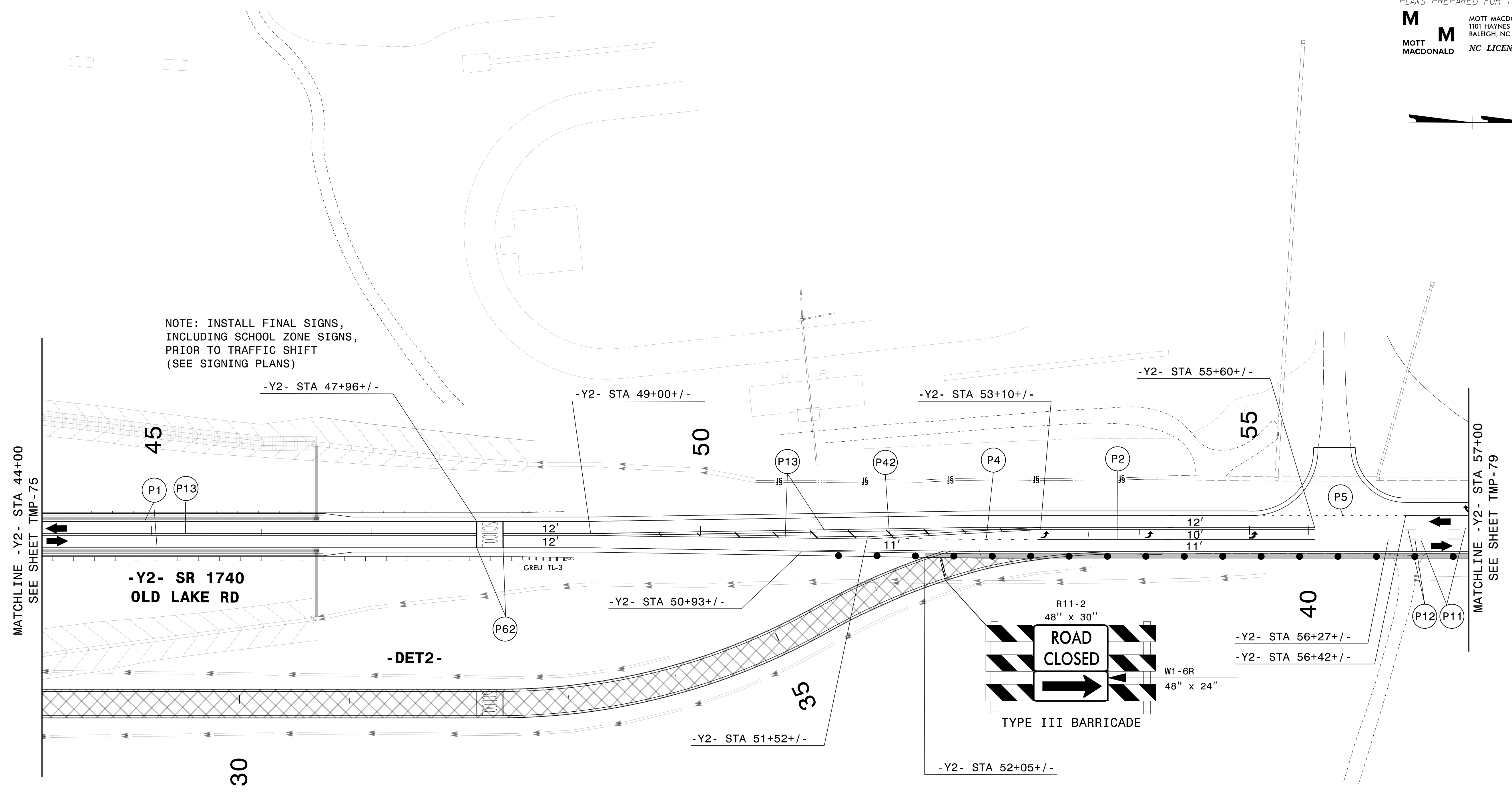
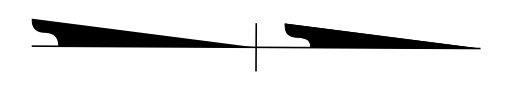

NOTE: INSTALL FINAL SIGNS,
 INCLUDING SCHOOL ZONE SIGNS,
 PRIOR TO TRAFFIC SHIFT
 (SEE SIGNING PLANS)

MATCHLINE -Y2- STA 44+00
 SEE SHEET TMP-75

MATCHLINE -Y2- STA 57+00
 SEE SHEET TMP-79

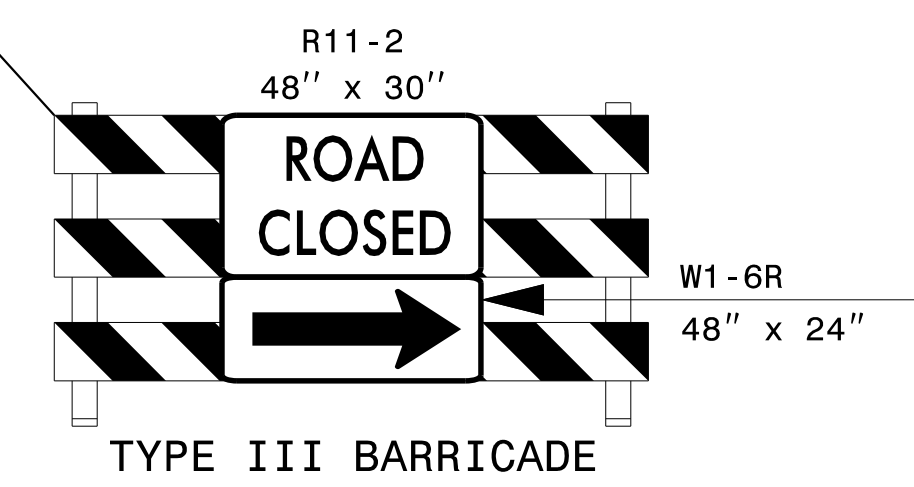

3/14/2022
 G:\501406565_Calyx_R5819_R5820\TrafficControl\CPNR-5819_R-5820\TC_TMP_78_P4B.dgn
 User:ST086227

APPROVED: *Lori D Stoucho*
DocuSigned by:
Lori D Stoucho
7A92E40FD7874C7...

DATE: 4/13/2022

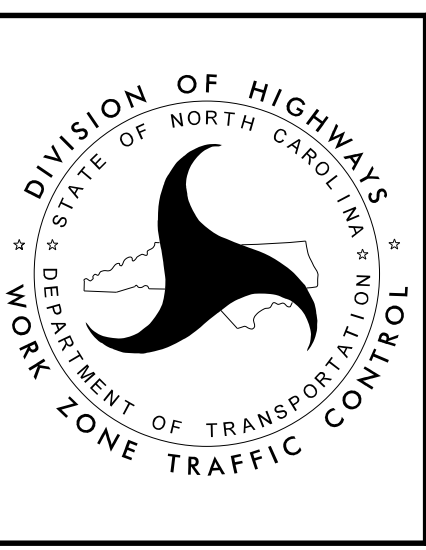

TEMPORARY TRAFFIC CONTROL
 AREA 2
 PHASE IVB

**DOCUMENT NOT CONSIDERED FINAL
 UNLESS ALL SIGNATURES COMPLETED**

PROJ. REFERENCE NO.	SHEET NO.
R-5819 R-5820	TMP-79

PLANS PREPARED FOR THE NCDOT BY:
M MOTT MACDONALD I & E, LLC
 1101 HAYNES STREET, SUITE 101
 RALEIGH, NC 27604
M MOTT MACDONALD
 NC LICENSE NO. F-0669

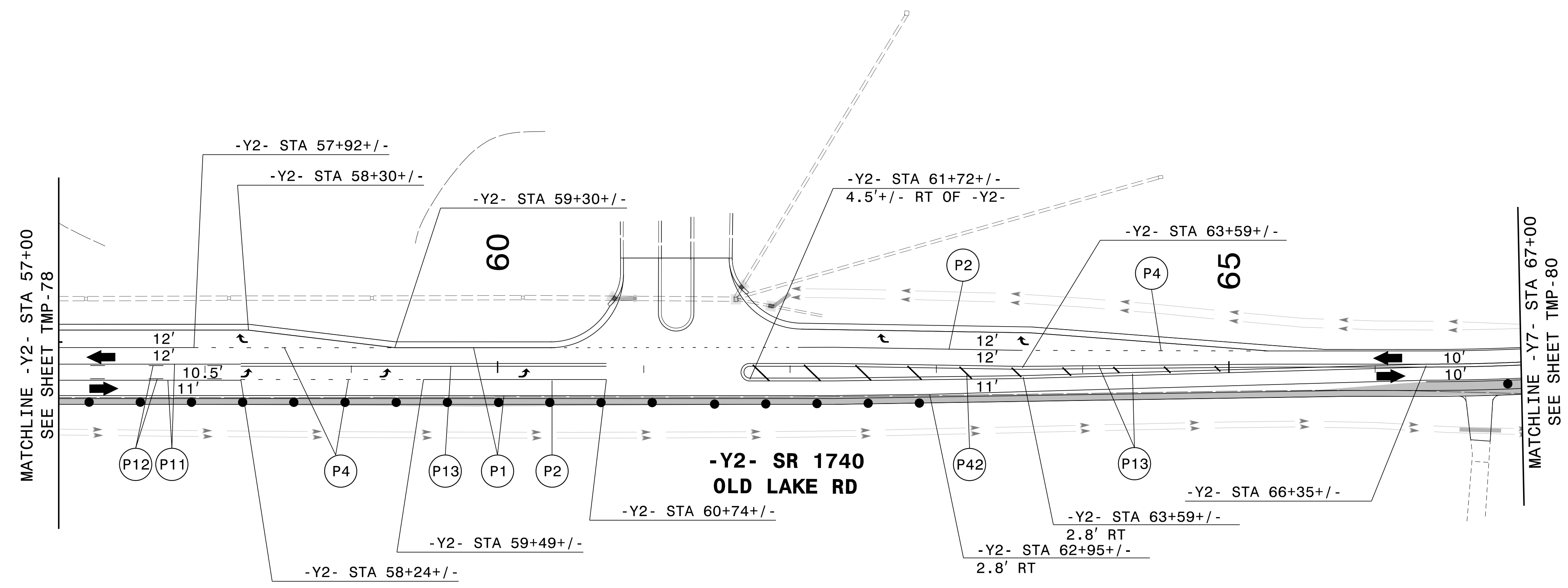
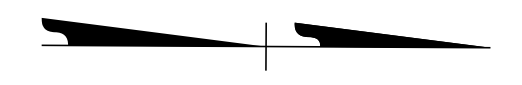

3/14/2022
 G:\501406565_Calyx_R5820\IR-5819_R-5820\TrafficControl\CPNR-5819_R-5820_TC_TMP_79_P4B.dgn
 User:ST086227

APPROVED: *Lori D Stoucho*
 DATE: 4/13/2022

DocuSigned by:
 Lori D Stoucho
 7A92E46FD7874C7...

**DOCUMENT NOT CONSIDERED FINAL
 UNLESS ALL SIGNATURES COMPLETED**

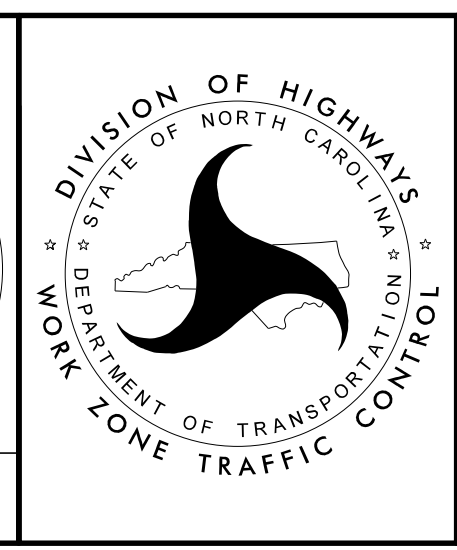

**TEMPORARY TRAFFIC CONTROL
 AREA 2
 PHASE IVB**

PLANS PREPARED FOR THE NCDOT BY:

M MOTT MACDONALD I & E, LLC
1101 HAYNES STREET, SUITE 101
RALEIGH, NC 27604
NC LICENSE NO. F-0669

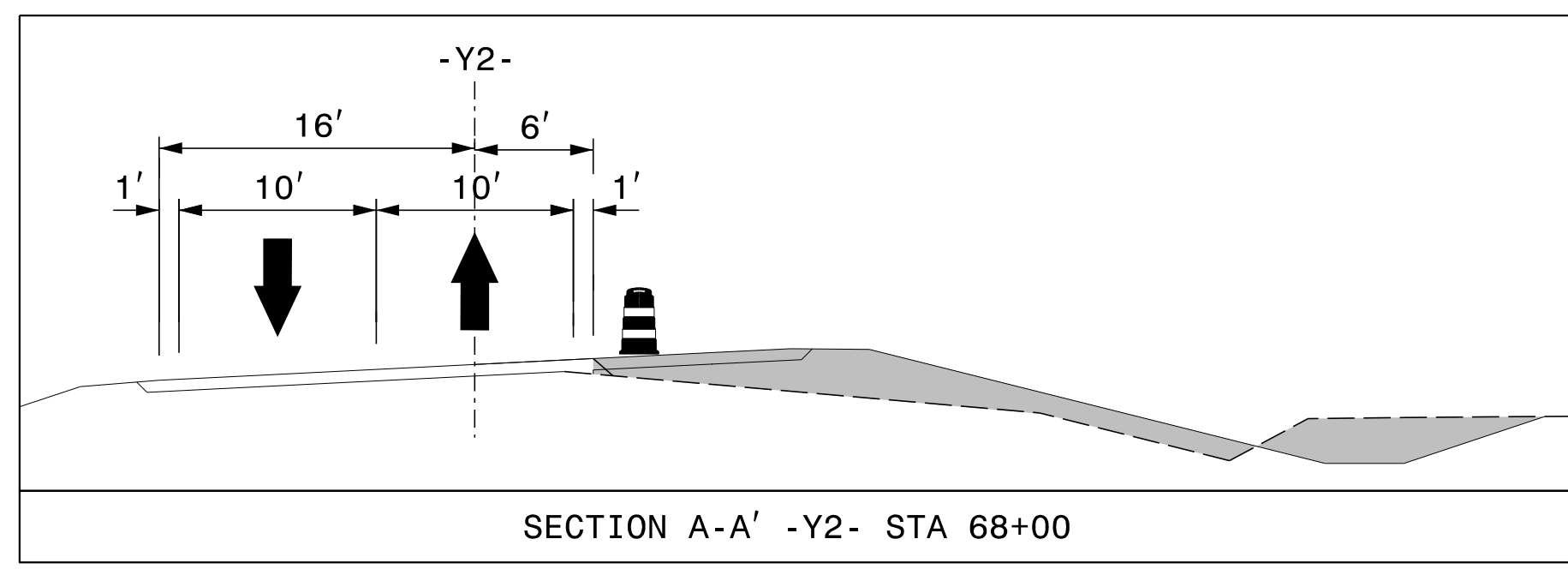
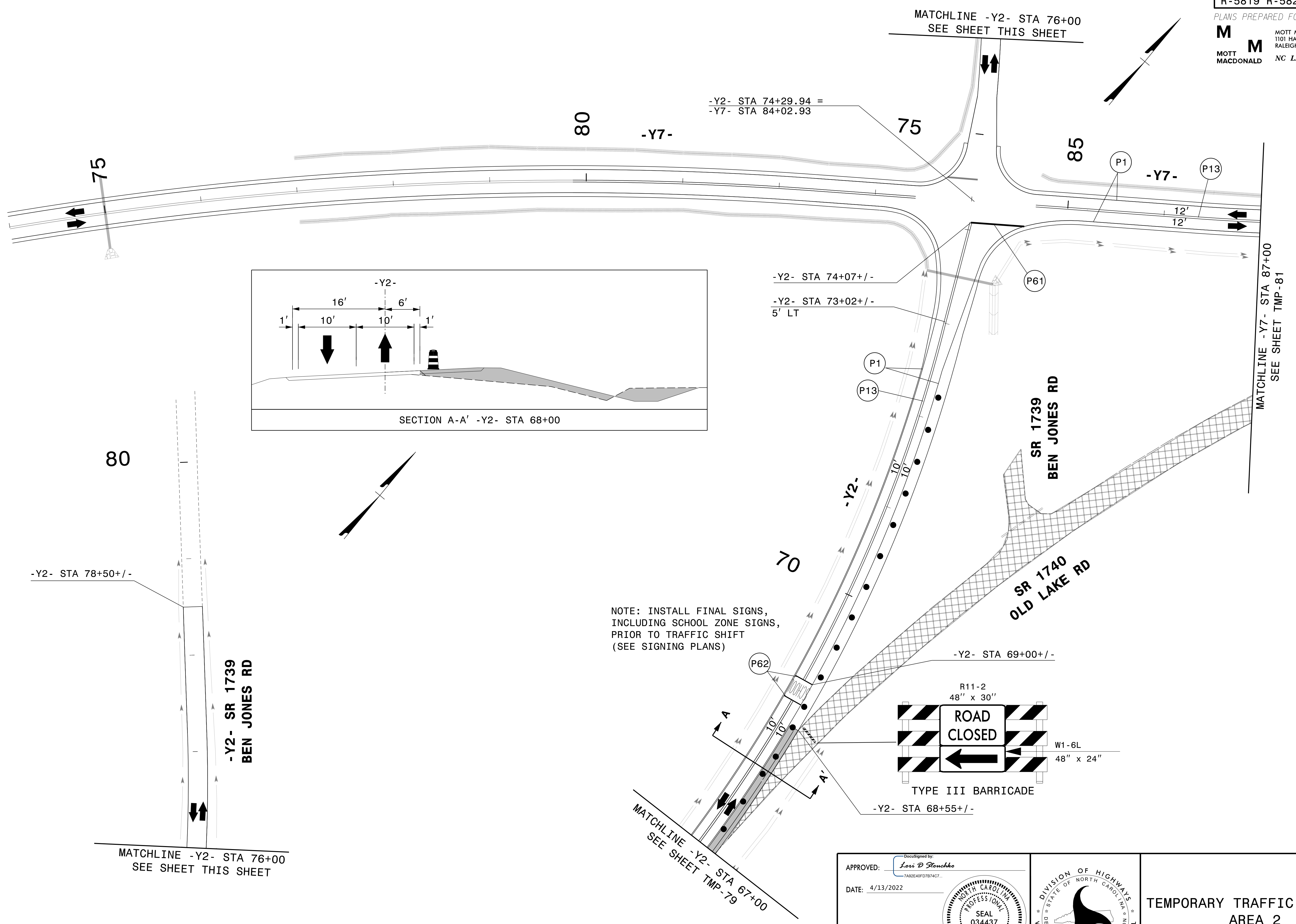

NOTE: INSTALL FINAL SIGNS, INCLUDING SCHOOL ZONE SIGNS, PRIOR TO TRAFFIC SHIFT (SEE SIGNING PLANS)

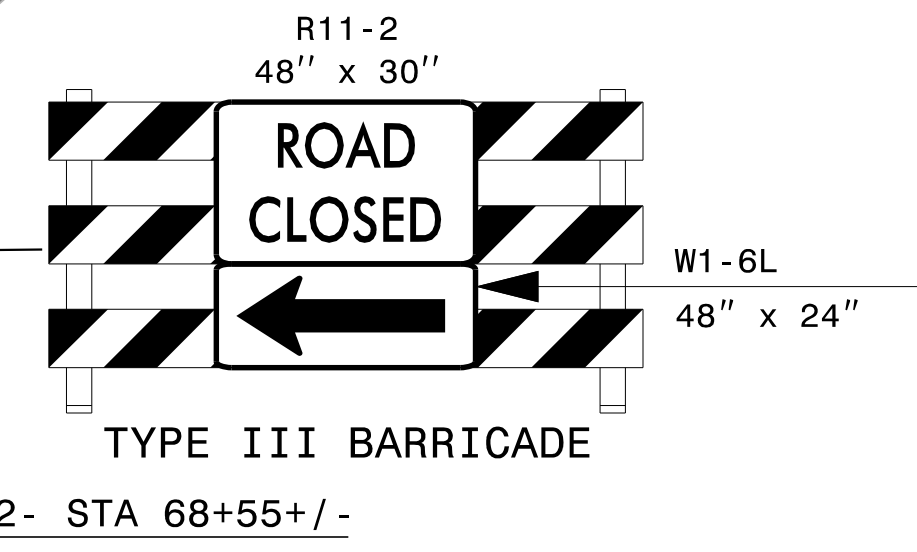

APPROVED: *Lori D. Stoucho*
DATE: 4/13/2022

Seal of Lori D. Stoucho, Professional Engineer, License No. 034437, State of North Carolina.

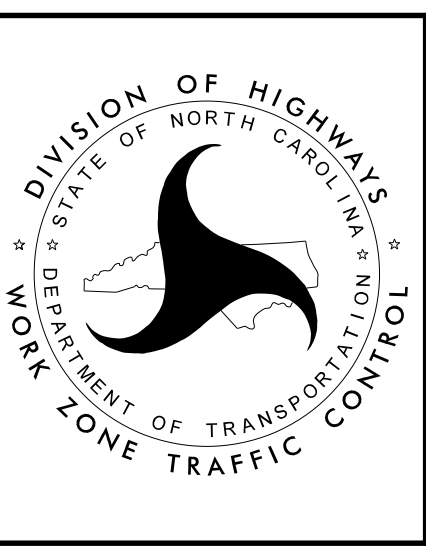

TEMPORARY TRAFFIC CONTROL
AREA 2
PHASE IVB

3/14/2022
G:\501406565_Calyx_R5819_R5820\TrafficControl\TCP\N-5819_R-5820_TC_TMP_80_P4B.dgn
User:ST086227

PLANS PREPARED FOR THE NCDOT BY:
M MOTT MACDONALD I & E, LLC
 1101 HAYNES STREET, SUITE 101
 RALEIGH, NC 27604
M MOTT MACDONALD
 NC LICENSE NO. F-0669

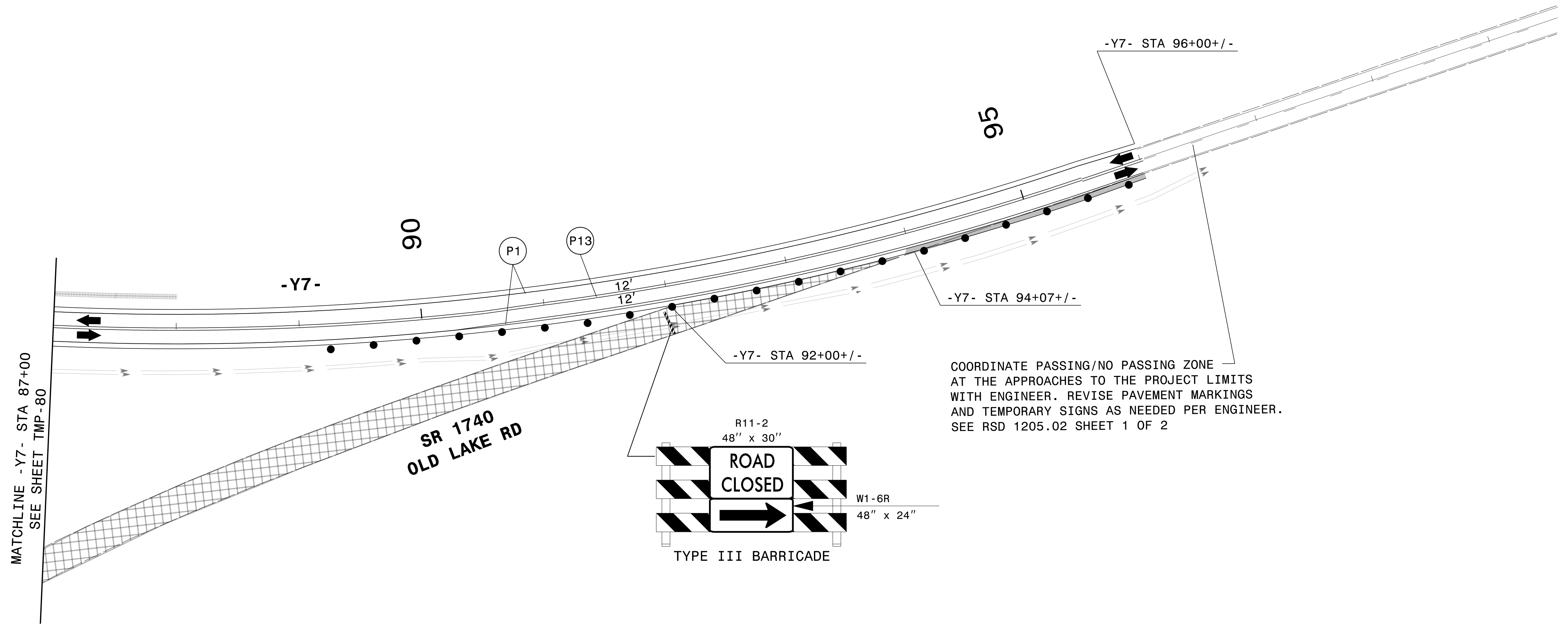
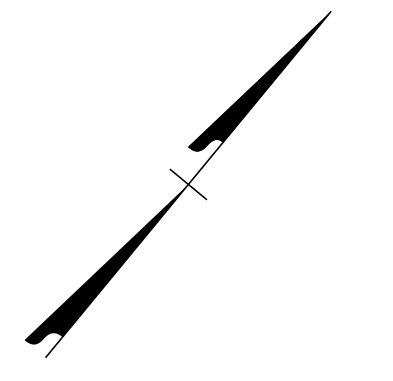

COORDINATE PASSING/NO PASSING ZONE AT THE APPROACHES TO THE PROJECT LIMITS WITH ENGINEER. REVISE PAVEMENT MARKINGS AND TEMPORARY SIGNS AS NEEDED PER ENGINEER. SEE RSD 1205.02 SHEET 1 OF 2

3/14/2022
 G:\501406565_Calyx_R5819_R5820\TrafficControl\CP\N-R-5819_R-5820_TC_TMP_81_P4B.dgn
 User:ST086227

APPROVED: *Lori D Stoucho*
DocuSigned by:
Lori D Stoucho
7AB2E4DFD7874C7...

DATE: 4/13/2022

**DOCUMENT NOT CONSIDERED FINAL
 UNLESS ALL SIGNATURES COMPLETED**

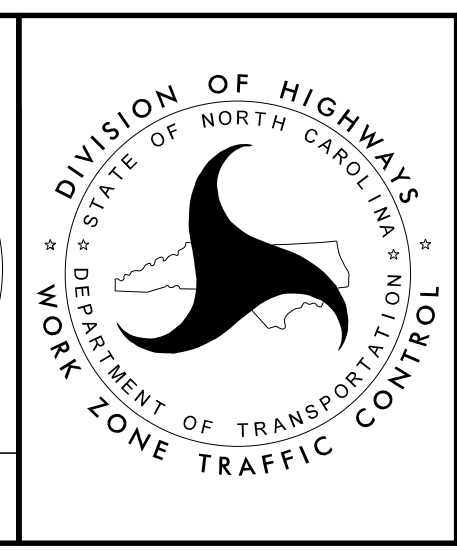

**TEMPORARY TRAFFIC CONTROL
 AREA 2
 PHASE IVB**