

ELEVATION VIEW

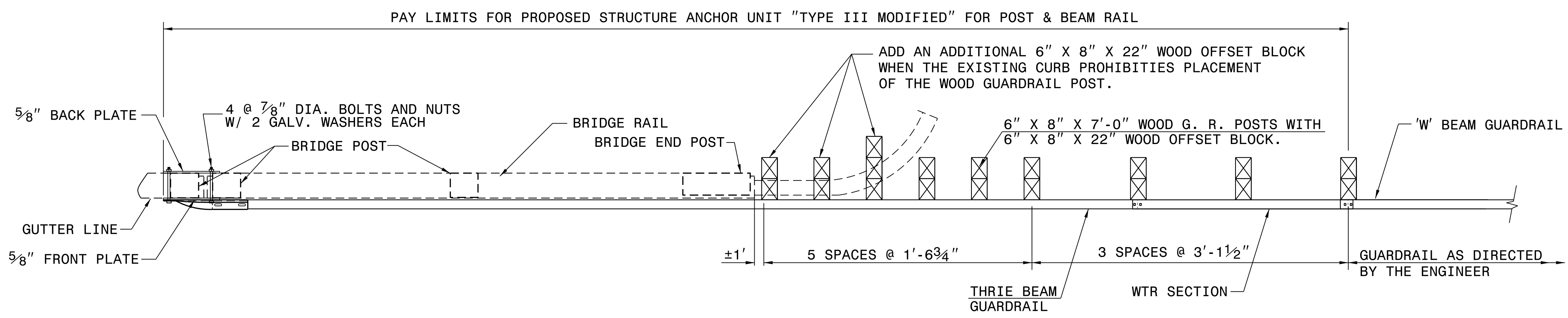

PLAN VIEW

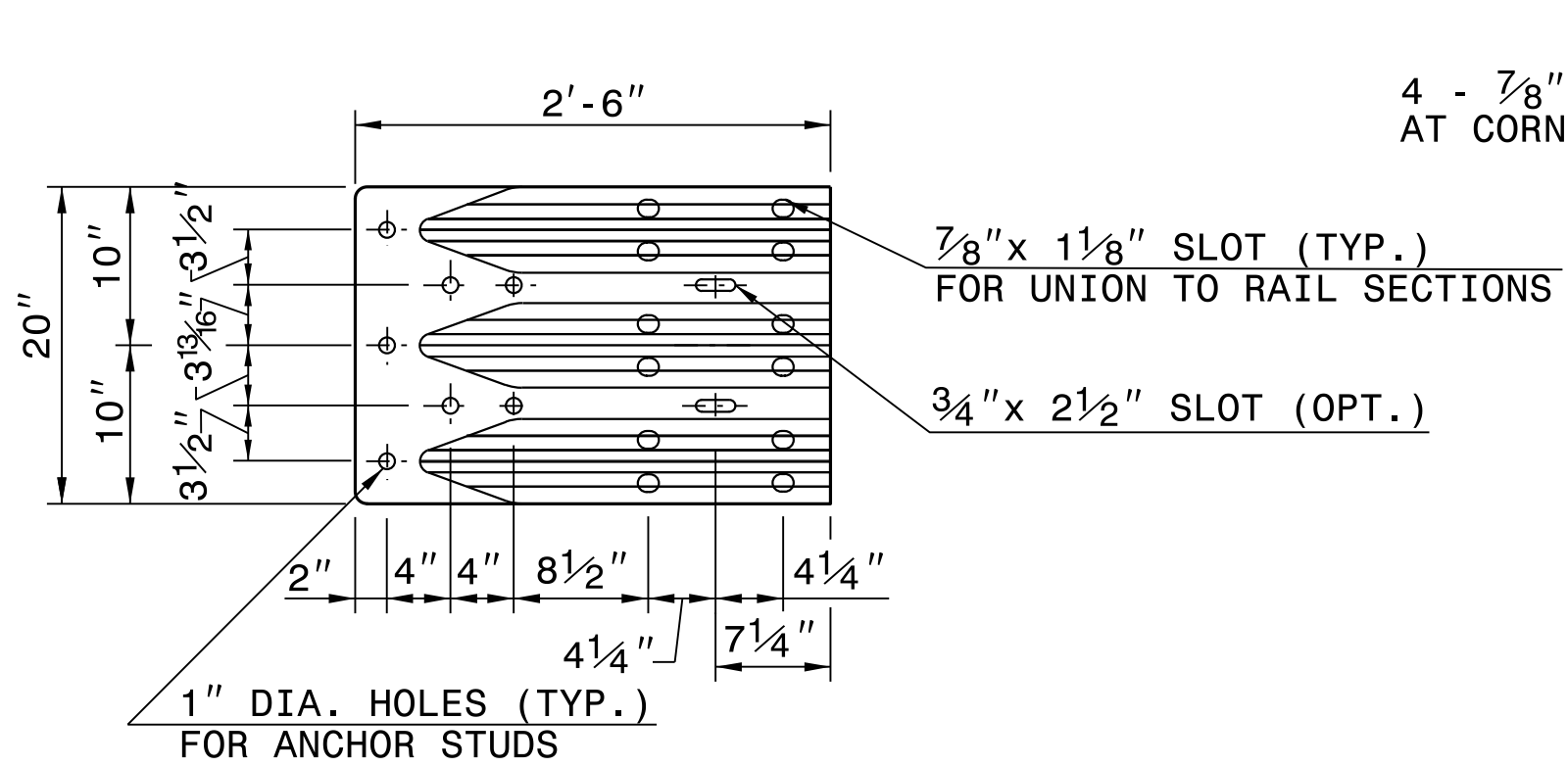

END SHOE

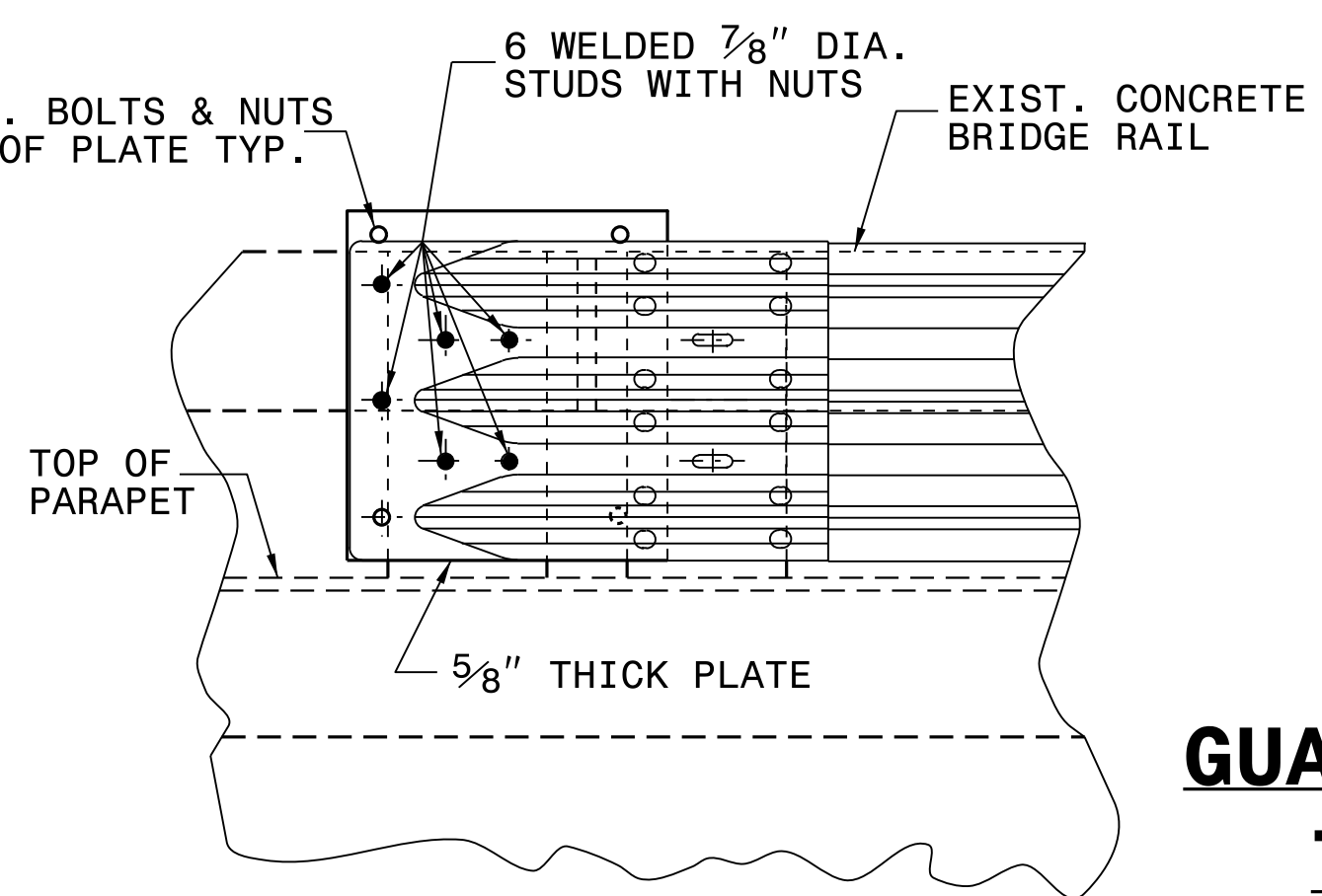

ELEVATION VIEW

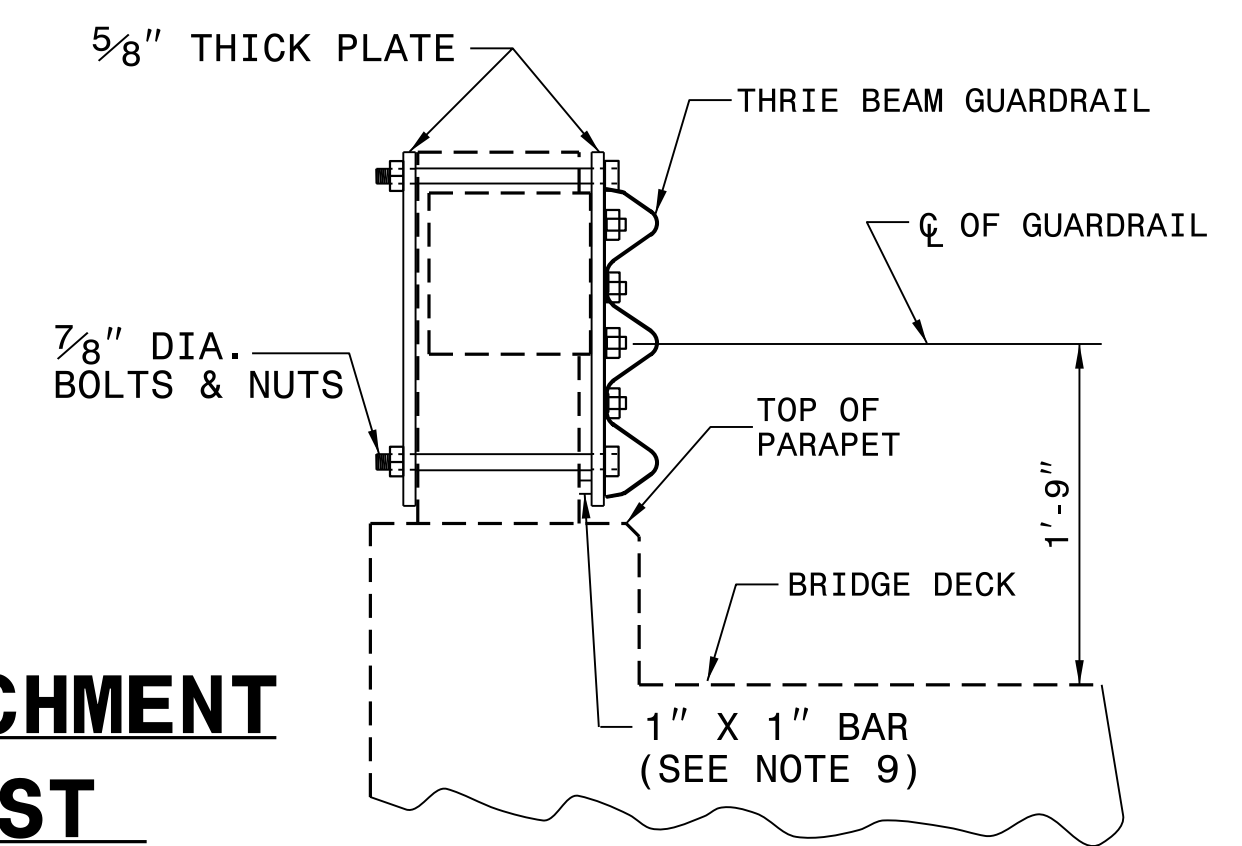

SECTION VIEW

GUARDRAIL ATTACHMENT TO BRIDGE POST

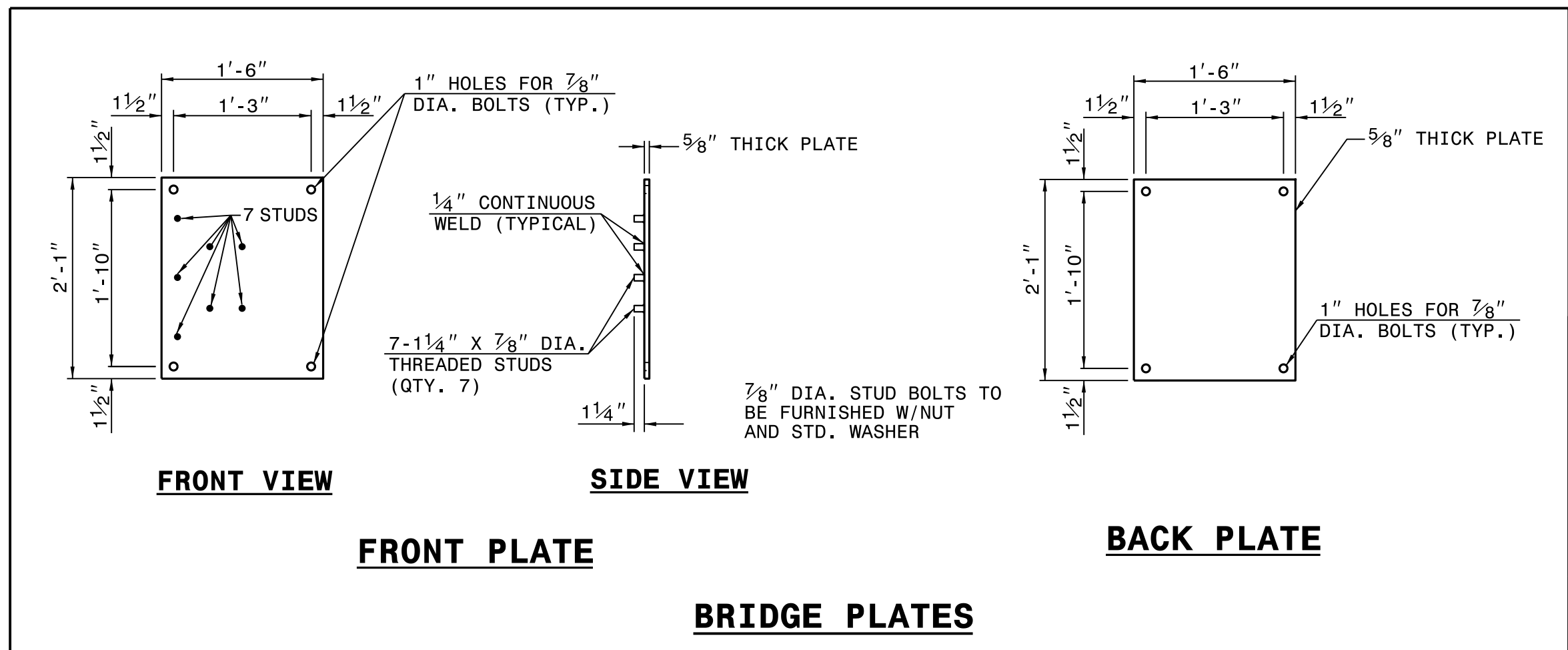

FRONT VIEW

SIDE VIEW

FRONT PLATE

BACK PLATE

BRIDGE PLATES

- GENERAL NOTES:**
1. USE NUTS, BOLTS, AND WASHERS CONFORMING TO THE REQUIREMENTS OF A.S.T.M. A-307 AND GALVANIZED IN ACCORDANCE WITH SECTION 1076 OF STAND. SPECS.
 2. TAP NUTS FOR THE 7/8" DIA. STUDS AND BOLTS AFTER GALVANIZING SEE A.S.T.M. A-563.
 3. USE PLATES AND TUBES CONFORMING TO THE REQUIREMENTS OF A.S.T.M. A-36 AND GALVANIZED AFTER FABRICATION IN ACCORDANCE WITH SECTION 1076 OF STAND. SPECS.
 4. ADDITIONAL FIELD HOLES MAY BE DRILLED IN STEEL RAIL AS DIRECTED BY THE ENGINEER.
 5. INSTALL FACE OF GUARDRAIL AS NEAR AS POSSIBLE TO PLUMB WITH THE PARAPET FACE AT BRIDGE END POST SPACER TUBE LOCATION BY USING STANDARD OR ALTERED SPACER TUBES OR A COMBINATION THEREOF OR AS DIRECTED BY THE ENGINEER. FOR VERY SMALL PARAPET WIDTHS, GUARDRAIL MAY BE INSTALLED AGAINST BRIDGE RAIL WITHOUT SPACER TUBES.
 6. DO NOT DRILL BRIDGE RAIL IN ORDER TO INSTALL GUARDRAIL ANCHOR UNIT.
 7. USE THIS DETAIL ONLY FOR BRIGES WITH POST AND BEAM TYPE RAIL.
 8. ATTACH 1" X 1" BAR AND THREADED STUDS TO PLATE WITH 1/4" WELDS ALL AROUND.
 9. 1" X 1" BAR MAY NOT BE NEEDED ON BRIDGE RAILS WHERE FACE OF RAIL DOES NOT PROJECT BEYOND FACE OF POST.
 10. PROVIDE SHOP DRAWINGS OF THE PLATES TO THE ENGINEER FOR APPROVAL BEFORE FABRICATING THE PLATES.
 11. LAP JOINTS IN THE DIRECTION OF TRAFFIC FLOW.
 12. SEE ROADWAY STARDARD DRAWING 862.03 SHEET 3 FOR ADDITIONAL INFORMATION ON THE TYPE III ANCHOR UNIT



03/03/2022

DOCUMENT NOT CONSIDERED FINAL UNLESS ALL SIGNATURES COMPLETED

CONTRACT STANDARDS AND DEVELOPMENT UNIT
Office 919-707-6950 FAX 919-250-4119

STRUCTURE ANCHOR UNIT TYPE III MODIFIED

ORIGINAL BY: C.O. CUEVAS DATE: 12-00
 MODIFIED BY: JS HOWERTON DATE: 01-18
 CHECKED BY: DATE:
 FILE SPEC.: \usr\details\stand\bp\iii.dgn

24-JAN-2018 14:52 S:\Contracts\Special Details\vertical\usr\details\stand\bp_iii_orig\orig.dgn .jpower ton AT USD-292595