

NOTES:

REPAIR LOCATIONS AND ESTIMATE OF QUANTITIES ARE GIVEN WITH THE BEST INFORMATION AVAILABLE. IF ADDITIONAL REPAIRS NOT SHOWN ON THE DRAWINGS ARE DEEMED NECESSARY BY THE INSPECTOR OR ENGINEER, THE CONTRACTOR SHALL NOTE ON THE DRAWINGS THE APPROXIMATE LOCATION AND DESCRIPTION OF THE REPAIRS AND ADJUST THE ACTUAL QUANTITIES ENTERED INTO THE REPAIR QUANTITY TABLE.

FOR CAP AND COLUMN REPAIR DETAILS, SEE "TYPICAL CAP AND COLUMN REPAIR DETAILS" SHEET.

FOR SHOTCRETE REPAIRS, SEE SPECIAL PROVISIONS.

FOR CONCRETE REPAIRS, SEE SPECIAL PROVISIONS.

FOR EPOXY RESIN INJECTION, SEE SPECIAL PROVISIONS.

CONCRETE REPAIRS MAY BE SUBSTITUTED IN LIEU OF SHOTCRETE REPAIRS WITH THE APPROVAL OF THE ENGINEER.

-  CONCRETE REPAIR
-  SHOTCRETE REPAIR
- ERI EPOXY RESIN INJECTION
- EXISTING
- J - JACKET
- E - ENCAPSULATION
- P - PILE

REPAIR QUANTITY TABLE

BENT 4	QUANTITIES			
	ESTIMATE		ACTUAL	
SHOTCRETE REPAIR	AREA SF	VOLUME CF	AREA SF	VOLUME CF
CAP (VERTICAL FACE)	31.5	15.8		
CAP (HORIZONTAL FACE)	0.0	0.0		
COLUMN	0.0	0.0		
CONCRETE REPAIR				
CAP (VERTICAL FACE)	0.0	0.0		
CAP (HORIZONTAL FACE)	0.0	0.0		
COLUMN	0.0	0.0		
EPOXY RESIN INJECTION		LF		LF
CAP		0.0		
COLUMN		0.0		

VALUES IN CHART REPRESENT ESTIMATED REPAIR TOTALS AFTER REMOVAL OF UNSOUND CONCRETE, MINIMUM OF 1" BEHIND REBAR AND MINIMUM 2" CLEARANCE TO SAWCUT. SEE "TYPICAL CAP AND COLUMN REPAIR DETAILS" SHEET.

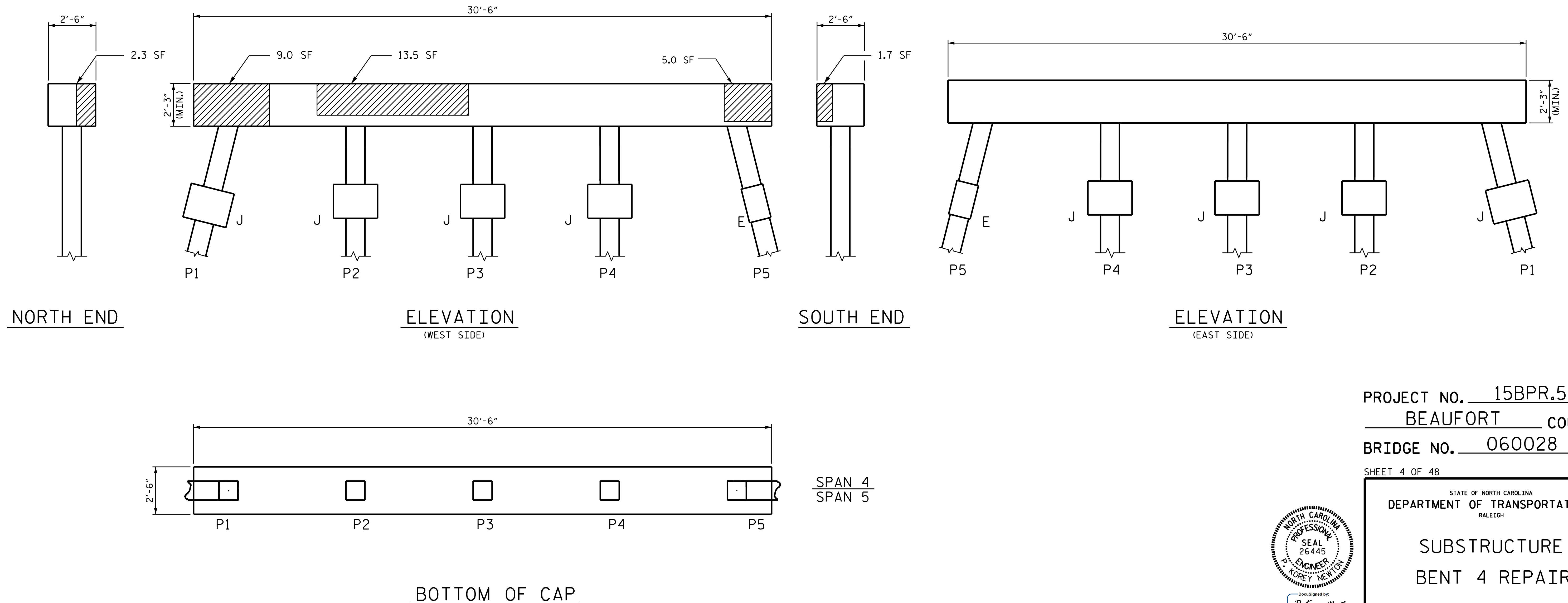

NORTH END

ELEVATION
(WEST SIDE)

SOUTH END

ELEVATION
(EAST SIDE)

BOTTOM OF CAP

PROJECT NO. 15BPR.56
BEAUFORT COUNTY
 BRIDGE NO. 060028

SHEET 4 OF 48

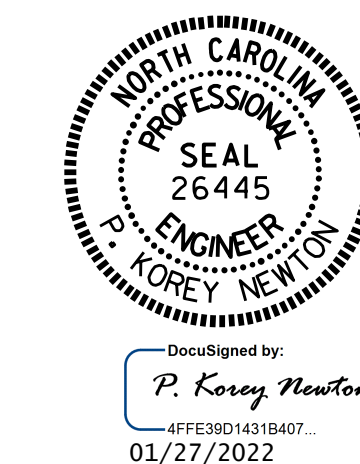

STATE OF NORTH CAROLINA
 DEPARTMENT OF TRANSPORTATION
 RALEIGH

SUBSTRUCTURE
BENT 4 REPAIR

DRAWN BY : S. T. SANDOR DATE : .05/2021
 CHECKED BY : W. C. SMITH DATE : .06/2021

DOCUMENT NOT CONSIDERED
 FINAL UNLESS ALL
 SIGNATURES COMPLETED

REVISIONS						SHEET NO.
NO.	BY:	DATE:	NO.	BY:	DATE:	
1			3			S3-22
2			4			TOTAL SHEETS 78