

**ELEVATION**  
(SECTION ALONG  $\text{CL}$  ROADWAY)

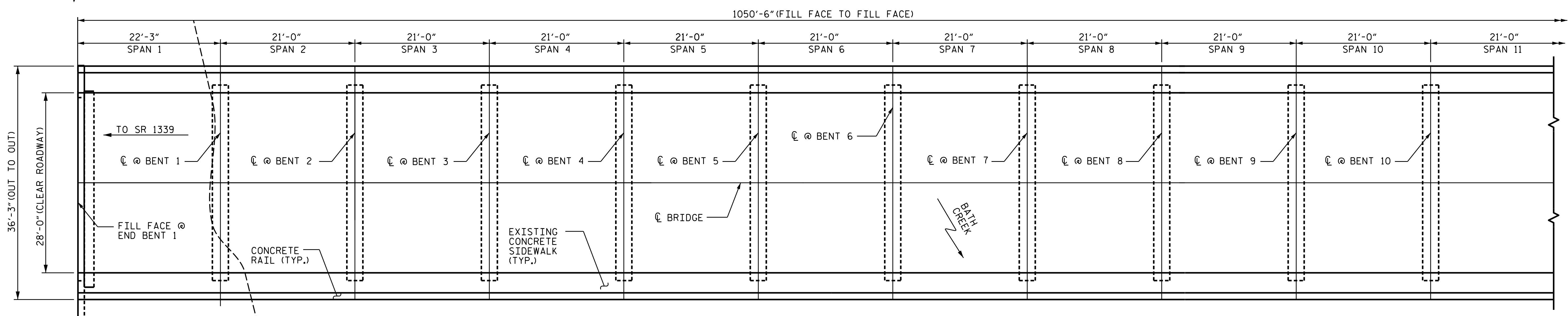

**PLAN**  
(PILES NOT SHOWN FOR CLARITY)

**SCOPE OF WORK**

- REMOVE AND REPLACE EXISTING SPAN 25 WITH PROPOSED STEEL GIRDERS AND REINFORCED CONCRETE DECK.
- EPOXY RESIN INJECTION OF CONCRETE CRACKS.
- REMOVE UNSOUND CONCRETE AND PROPERLY PREPARE SHOTCRETE AND CONCRETE REPAIR AREAS.
- PERFORM SHOTCRETE AND CONCRETE REPAIRS IN PREPARED AREAS.
- PARTIALLY REMOVE BRIDGE DECK CONCRETE BY SCARIFICATION AND SHOTBLASTING METHODS.
- PERFORM CONCRETE DECK REPAIRS IN PREPARED AREAS.
- OVERLAY PREPARED BRIDGE DECK WITH POLYMER CONCRETE OVERLAY (PC).
- GROOVE POLYMER CONCRETE BRIDGE DECK.
- REMOVE EXISTING JOINT MATERIAL AND INSTALL SILICONE JOINT SEALS.
- MILL AND REPAVE ASPHALT APPROACH ROADWAYS.

**NOTES**

GENERAL DRAWING INFORMATION IS TAKEN FROM THE ORIGINAL PLANS AND THE ROUTINE INSPECTION REPORT DATED 06/05/2020.  
BRIDGE ORIENTATION CONFORMS TO THE ORIGINAL BRIDGE PLANS.

AT THE TIME OF PREPARATION OF THESE PLANS, IT WAS NOT ANTICIPATED THAT ITEMS SHOWN BELOW WOULD BE REQUIRED. HOWEVER, IT MAY BE DETERMINED IN THE FIELD THAT THESE ITEMS, OR OTHER WORK WILL BE NECESSARY TO PROPERLY COMPLETE THE INTENDED BRIDGE PRESERVATION/REHABILITATION WORK. THE CONTRACTOR SHALL BE PREPARED TO PERFORM SUCH WORK IN A TIMELY MANNER, AS DETERMINED IN THE FIELD. SUCH WORK SHALL BE CONSIDERED EXTRA WORK AND SHALL BE ADDRESSED AS PER ARTICLE 104-7 OF THE STANDARD SPECIFICATIONS. PROJECT SPECIAL PROVISIONS THAT OUTLINE REQUIREMENTS FOR THESE POTENTIAL ADDITIONAL WORK ITEMS HAVE BEEN PROVIDED IN PROJECT DOCUMENTS, BUT NO QUANTITIES HAVE BEEN LISTED. ACTUAL PAY ITEMS, QUANTITIES, AND COSTS WILL BE ESTABLISHED, AS REQUIRED, IF EXTRA WORK IS ENCOUNTERED.

**UNANTICIPATED ITEMS:**

ITEM NO.	DESCRIPTION	UNIT
1	CLASS III SURFACE PREPARATION	SO. YD.

I HEREBY CERTIFY THAT THIS STRUCTURE WAS REHABILITATED ACCORDING TO THESE PLANS OR AS NOTED HEREIN.

RESIDENT ENGINEER \_\_\_\_\_ DATE \_\_\_\_\_

PROJECT NO. 15BPR.56  
BEAUFORT COUNTY  
 BRIDGE NO. 060028

SHEET 1 OF 5

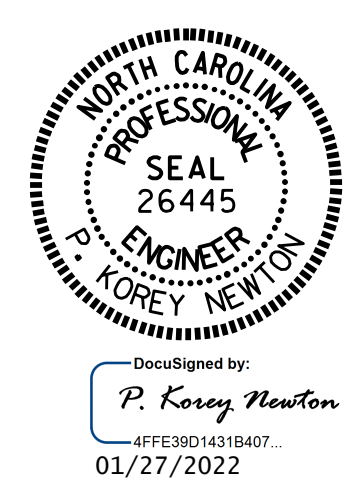

STATE OF NORTH CAROLINA  
 DEPARTMENT OF TRANSPORTATION  
 RALEIGH

**GENERAL DRAWING**

FOR BRIDGE ON NC 92  
 OVER BATH CREEK  
 BETWEEN  
 SR 1339 AND SR 1741

DRAWN BY : S. T. SANDOR DATE : 08/2021  
 CHECKED BY : W. C. SMITH DATE : 08/2021

DOCUMENT NOT CONSIDERED  
 FINAL UNLESS ALL  
 SIGNATURES COMPLETED

REVISIONS						SHEET NO.
NO.	BY:	DATE:	NO.	BY:	DATE:	
1			3			S3-01
2			4			TOTAL SHEETS 78