

NOTES:

CONTRACTOR SHALL FIELD VERIFY THE EXISTING FORMED OPENING PRIOR TO OBTAINING JOINT MATERIAL. IF ACTUAL JOINT OPENINGS VARIES FROM THE OPENING INDICATED IN DETAIL MORE THAN 1/4" NOTIFY ENGINEER. REVISION TO THE JOINT SEAL SIZE MAY BE NECESSARY.

THE CONTRACTOR SHALL TAKE CARE DURING JOINT REHAB OPERATIONS NOT TO DROP ANY MATERIAL BELOW THE BRIDGE WITHOUT PROTECTIVE DEVICES BELOW TO CATCH THE MATERIAL. ANY MATERIAL THAT FALLS BELOW THE BRIDGE SHALL BE CONTAINED, REMOVED AND DISPOSED OF BY THE CONTRACTOR AT NO EXTRA COST TO THE DEPARTMENT. IF THE ENGINEER DETERMINES THAT THE PROTECTIVE DEVICES ARE NOT ADEQUATE OR NOT BEING EMPLOYED, THE WORK SHALL BE SUSPENDED UNTIL ADEQUATE PROTECTION IS PROVIDED.

FOR POURABLE SILICONE JOINT SEALANT, SEE SPECIAL PROVISIONS.

SILICONE JOINT SEALANT AND BACKER ROD SHALL BE INSTALLED AS PER MANUFACTURER'S RECOMMENDATION.

THE INSTALLATION OF JOINT SEAL SHALL BE WATERTIGHT.

FINAL JOINT SEALS SHALL NOT BE INSTALLED UNTIL THE SILANE DECK TREATMENT IS COMPLETE.

DURING JOINT INSTALLATION PROCEDURE, THE JOINT AND SURROUNDING AREA SHALL BE KEPT CLEAN AND FREE OF DEBRIS.

REMOVAL OF EXISTING JOINT MATERIAL SHALL BE CONSIDERED INCIDENTAL TO POURABLE SILICONE JOINT SEALANT.

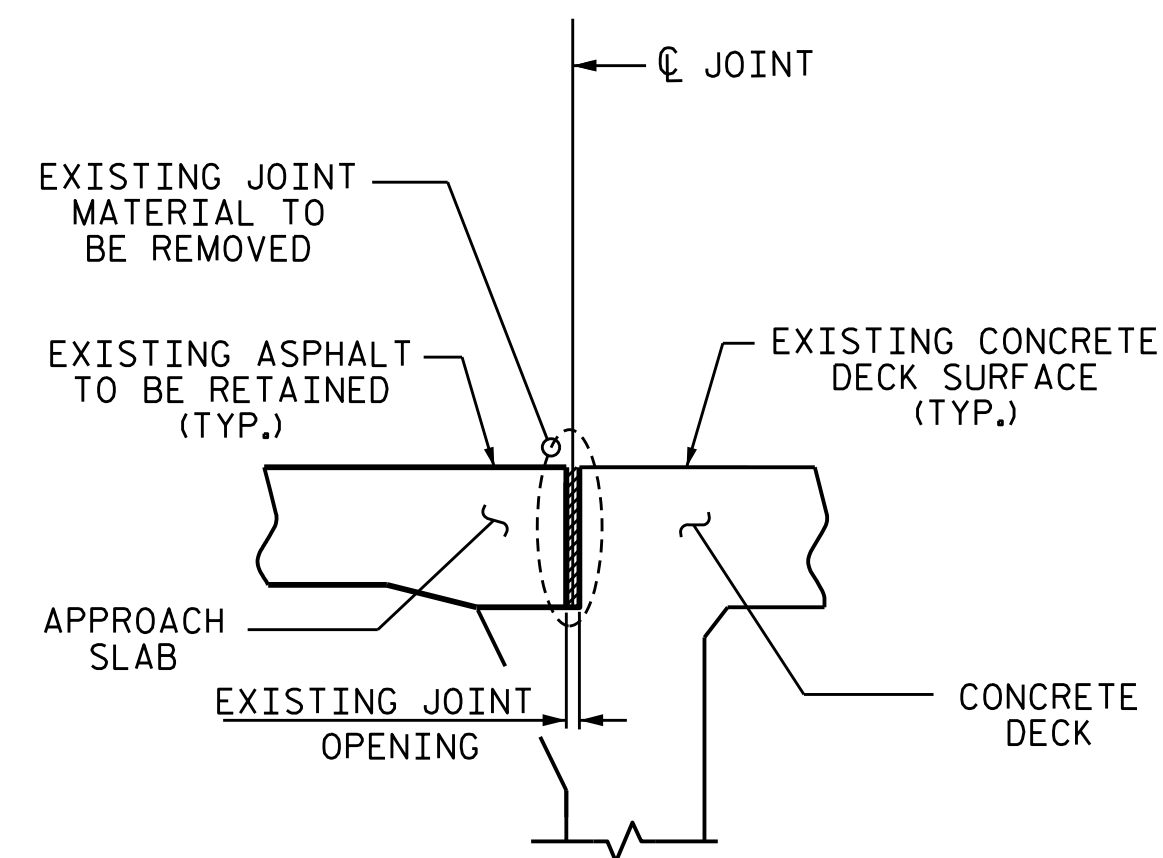

SECTION A-A
(EXISTING JOINT)

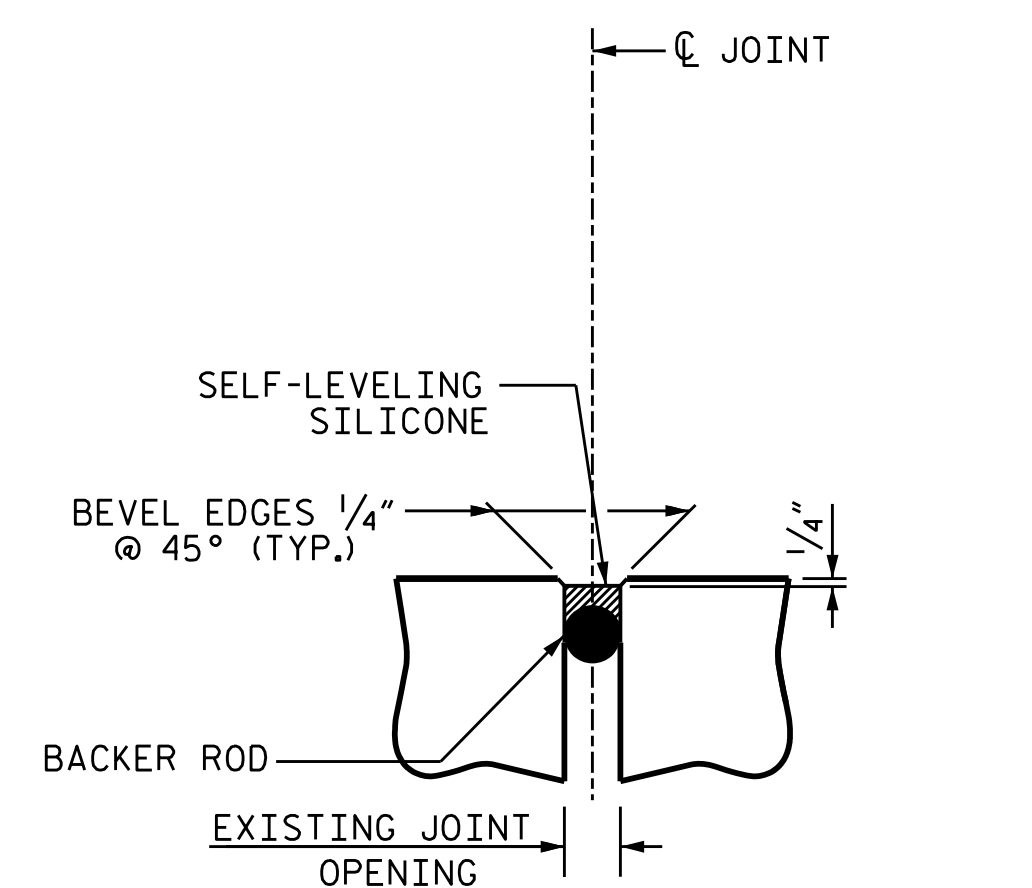

PROPOSED JOINT SEAL DETAIL

SUMMARY OF QUANTITIES		
(TYP.)	ESTIMATE	ACTUAL
POURABLE SILICONE JOINT SEALANT	48.0 L.F.	

PROJECT NO. 15BPR.56
BEAUFORT COUNTY
 BRIDGE NO. 060027



STATE OF NORTH CAROLINA
 DEPARTMENT OF TRANSPORTATION
 RALEIGH
SUPERSTRUCTURE
JOINT REPAIR DETAILS

DRAWN BY : S. T. SANDOR DATE : 06/2021
 CHECKED BY : W. C. SMITH DATE : 07/2021

DOCUMENT NOT CONSIDERED
 FINAL UNLESS ALL
 SIGNATURES COMPLETED

REVISIONS						SHEET NO.
NO.	BY:	DATE:	NO.	BY:	DATE:	S2-4
1			3			TOTAL SHEETS
2			4			9