

END VIEW  
(WEST SIDE)

ELEVATION BENT 3  
(SOUTH SIDE)  
(LOOKING NORTH)

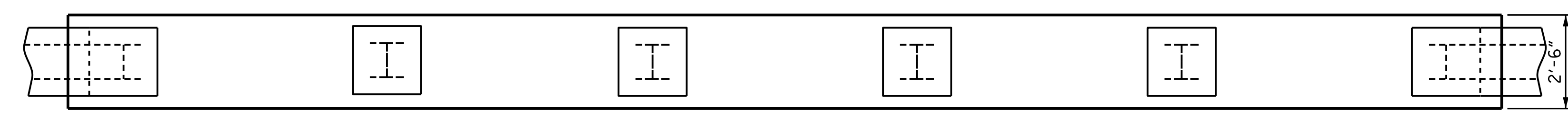

BOTTOM OF CAP

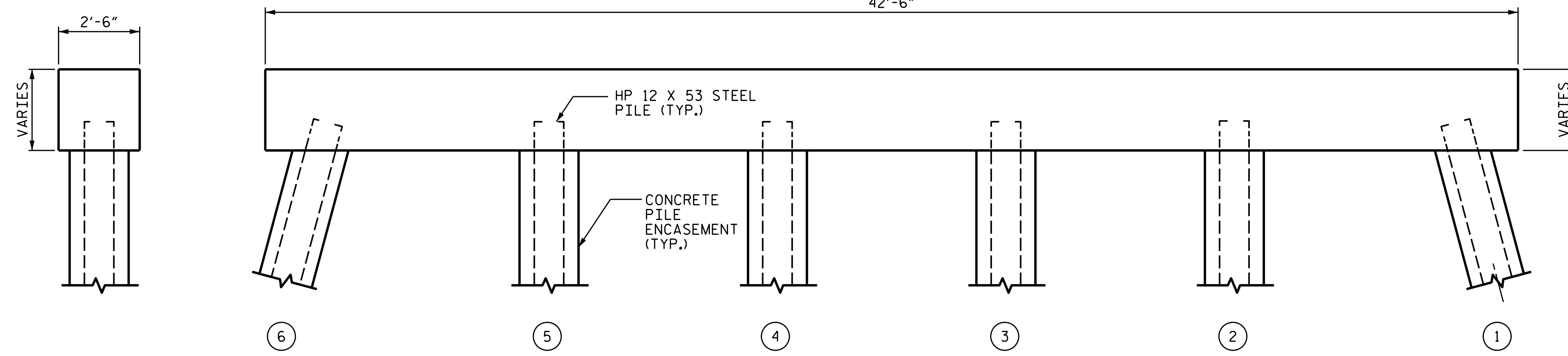

END VIEW  
(EAST SIDE)

ELEVATION BENT 3  
(NORTH SIDE)  
(LOOKING SOUTH)

AS-BUILT REPAIR QUANTITY TABLE				
BENT 3	QUANTITIES			
	ESTIMATE		ACTUAL	
SHOTCRETE REPAIRS	AREA SO. FT.	VOLUME CU. FT.	AREA SO. FT.	VOLUME CU. FT.
CAP	0.0	0.0		
COLUMN	0.0	0.0		
CONCRETE REPAIRS	AREA SO. FT.	VOLUME CU. FT.	AREA SO. FT.	VOLUME CU. FT.
CAP	0.0	0.0		
COLUMN	0.0	0.0		
EPOXY RESIN INJECTION	LIN. FT.		LIN. FT.	
CAP	0.0			
COLUMN	0.0			

VALUES IN CHART REPRESENT ESTIMATED REPAIR TOTALS AFTER REMOVAL OF UNSOUND CONCRETE, MINIMUM OF 1" BEHIND REBAR AND MINIMUM 2" CLEARANCE TO SAWCUT. SEE "TYPICAL CAP AND COLUMN REPAIR DETAILS" SHEET.

NOTES

REPAIR LOCATIONS AND ESTIMATE OF QUANTITIES ARE GIVEN BASED ON THE BEST INFORMATION AVAILABLE. IF ADDITIONAL REPAIRS NOT SHOWN ON THE DRAWINGS ARE DEEMED NECESSARY BY THE ENGINEER, THE ENGINEER SHALL NOTE ON THE DRAWINGS THE APPROXIMATE LOCATION AND DESCRIPTION OF THE REPAIRS AND ENTER THE ACTUAL QUANTITIES INTO THE AS-BUILT REPAIR QUANTITY TABLE.

CONCRETE REPAIRS MAY BE SUBSTITUTED IN LIEU OF SHOTCRETE REPAIRS WITH THE APPROVAL OF THE ENGINEER.

FOR SHOTCRETE REPAIRS, SEE SPECIAL PROVISIONS.

FOR CONCRETE REPAIRS, SEE SPECIAL PROVISIONS.

FOR EPOXY RESIN INJECTION, SEE SPECIAL PROVISIONS.

FOR CAP AND COLUMN REPAIR DETAILS, SEE "TYPICAL CAP AND COLUMN REPAIR DETAILS" AND "PRESTRESSED CONCRETE PILE REPAIR DETAILS" SHEET.

- SHOTCRETE REPAIR AREA
- CONCRETE REPAIR AREA
- ERI - EPOXY RESIN INJECTION
- PILE NUMBER

PROJECT NO. 15BPR.56  
BEAUFORT  
STATION: 060016

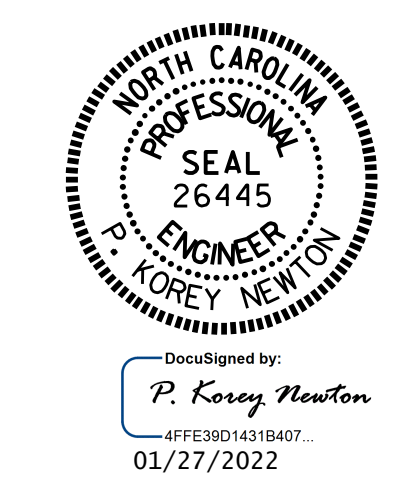

STATE OF NORTH CAROLINA  
DEPARTMENT OF TRANSPORTATION  
RALEIGH

SUPERSTRUCTURE

BENT 3 REPAIR

DRAWN BY : S. T. SANDOR DATE : 04/2021  
CHECKED BY : W. C. SMITH DATE : 06/2021

DOCUMENT NOT CONSIDERED FINAL UNLESS ALL SIGNATURES COMPLETED

REVISIONS						SHEET NO.
NO.	BY:	DATE:	NO.	BY:	DATE:	
1			3			S1-8
2			4			TOTAL SHEETS 8