

NOTES

FINAL JOINT SEALS SHALL NOT BE INSTALLED UNTIL THE OVERLAY OR SEALANT WORK IS COMPLETE.

THE CONTRACTOR SHALL FIELD VERIFY THE EXISTING JOINT OPENING PRIOR TO ORDERING JOINT SEAL MATERIAL. IF THE ACTUAL JOINT OPENING VARIES FROM THE OPENING INDICATED IN THE DETAILS BY MORE THAN 1/4", NOTIFY THE ENGINEER.

THE MANUFACTURER IS TO PROVIDE THE NOMINAL UNCOMPRESSED SEAL WIDTH OF THE FOAM JOINT SEAL FOR THE SIZE OF THE OPENING ON THE PLANS AND ACCOMODATE THE MINIMUM EXPANSION SHOWN ON THE PLANS.

FOAM JOINTS SHALL BE INSTALLED AS PER THE MANUFACTURER'S RECOMMENDATIONS.

THE CONTRACTOR SHALL TAKE CARE DURING JOINT REHAB OPERATIONS NOT TO DROP ANY MATERIAL BELOW THE BRIDGE, WITHOUT PROTECTIVE DEVICES BELOW TO CATCH THE MATERIAL. ANY MATERIAL THAT FALLS BELOW THE BRIDGE SHALL BE CONTAINED, REMOVED AND DISPOSED OF BY THE CONTRACTOR AT NO EXTRA COST TO THE DEPARTMENT. IF THE ENGINEER DETERMINES THAT THE PROTECTIVE DEVICES ARE NOT ADEQUATE OR NOT BEING EMPLOYED, THE WORK SHALL BE SUSPENDED UNTIL ADEQUATE PROTECTION IS PROVIDED.

THE CONTRACTOR WILL NOT BE PERMITTED TO FORM THE JOINTS IN LIEU OF SAWING THE JOINT.

THE INSTALLED FOAM JOINTS SHALL BE WATER TIGHT.

FOR FOAM JOINT SEALS FOR PRESERVATION, SEE SPECIAL PROVISIONS.

THE CONTRACTOR SHALL SAW CUT TO A NOMINAL DEPTH OF 1/2" BUT REINFORCING STEEL SHALL NOT BE DAMAGED. CONTRACTOR SHALL REMOVE SURFACE CONCRETE TO VERIFY THAT SAWCUT DEPTH WILL NOT DAMAGE EXISTING REINFORCING STEEL.

QUANTITIES SHOWN IN THE ELASTOMERIC CONCRETE FOR PRESERVATION TABLE ARE BASED ON THE MINIMUM JOINT DEMOLITION SHOWN.

FOR EXCAVATION BELOW THE BOTTOM OF PLANNED JOINT DEMOLITION, CONCRETE FOR DECK REPAIR SHALL BE PLACED IN THE EXCAVATED AREA TO THE ELEVATION AT THE BOTTOM OF THE PROPOSED ELASTOMERIC CONCRETE FOR PRESERVATION HEADERS SHOWN.

FINAL SURFACE OF THE JOINT DEMOLITION AREA PRIOR TO PLACEMENT OF CONCRETE REPAIR MATERIAL OR ELASTOMERIC CONCRETE SHOULD BE REASONABLY FLAT AND LEVEL. ENGINEER SHALL DETERMINE THE ACCEPTABILITY OF THE SURFACE PRIOR TO PLACEMENT OF REPAIR CONCRETE OR ELASTOMERIC CONCRETE.

FOR BRIDGE JOINT DEMOLITION, SEE SPECIAL PROVISIONS.

FOR ELASTOMERIC CONCRETE FOR PRESERVATION, SEE SPECIAL PROVISIONS.

FOR CONCRETE FOR DECK REPAIR, SEE SPECIAL PROVISIONS.

PROJECT NO. I-5831A
MADISON COUNTY
 BRIDGE NO. 560540

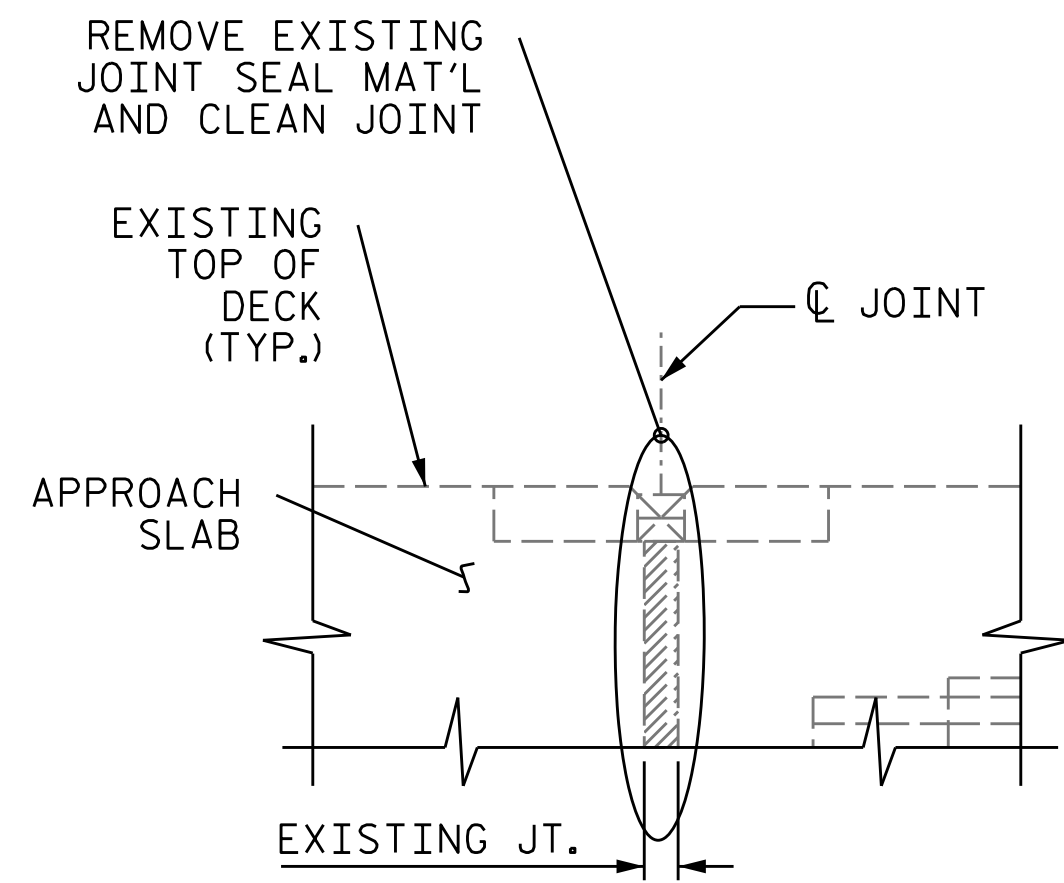

EXISTING JOINT SEAL

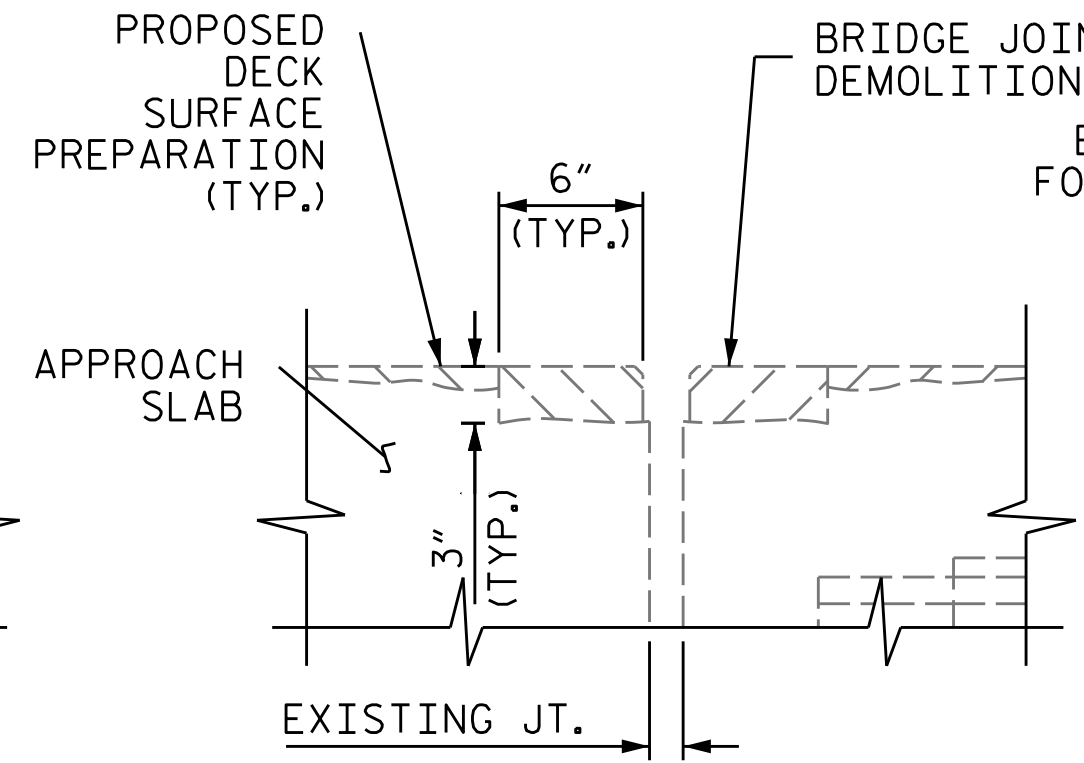

EXISTING JOINT AFTER JOINT DEMOLITION

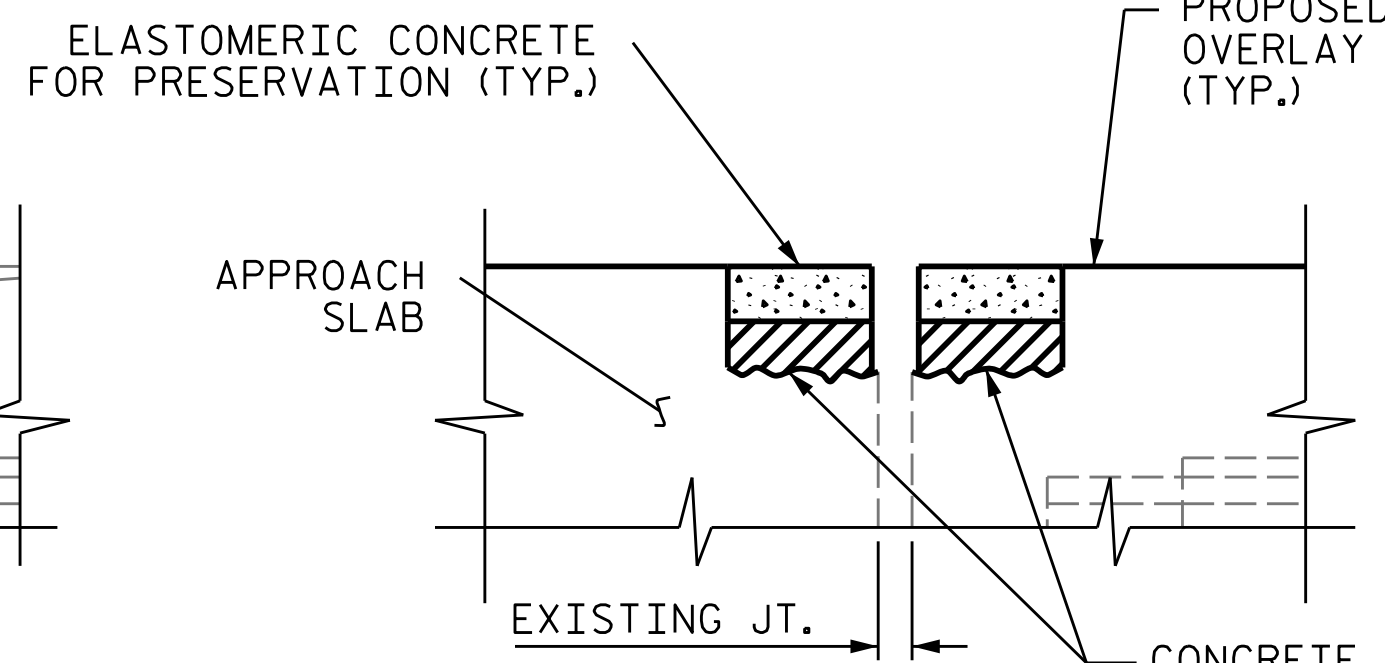

PROPOSED JOINT PRIOR TO SAWING

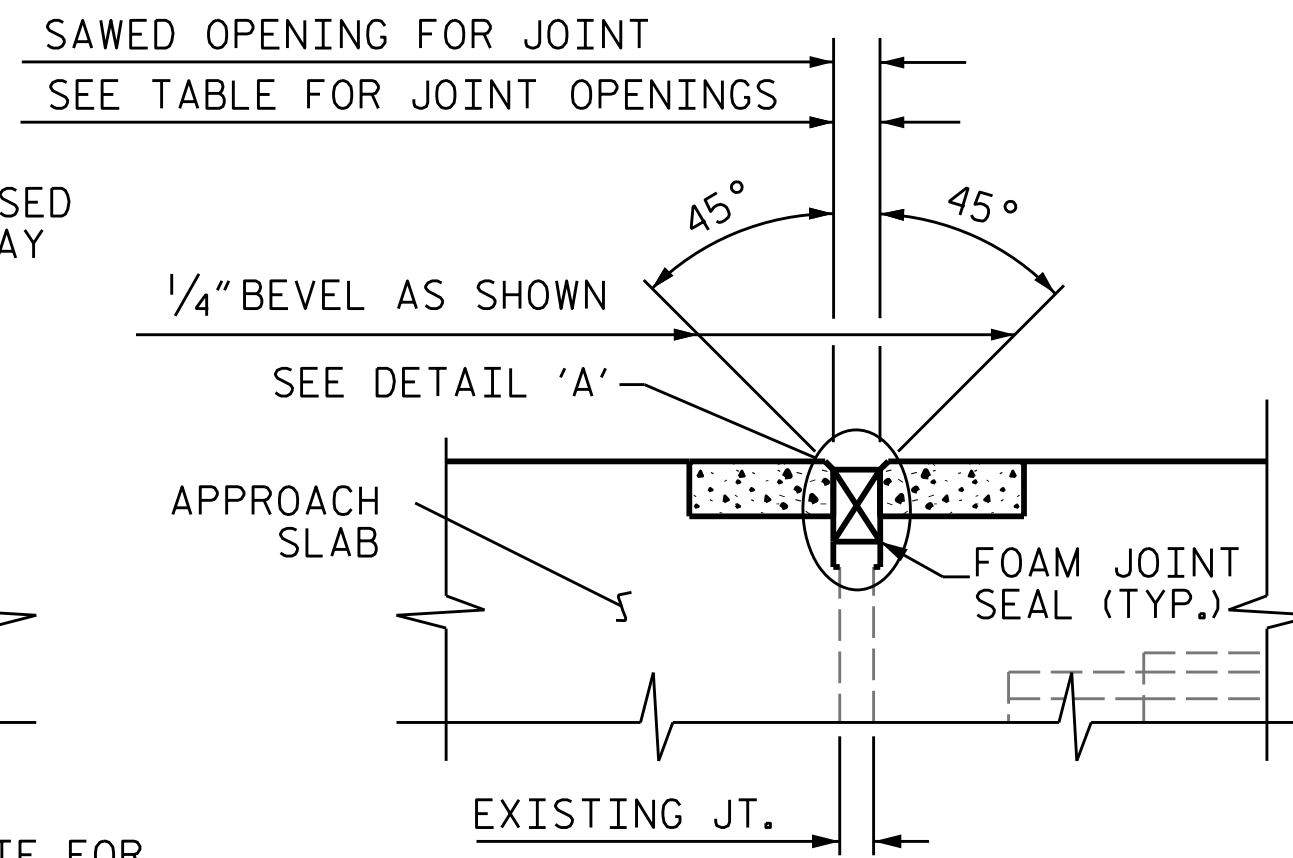

PROPOSED FOAM JOINT SEAL

SECTION A-A
(TYP. @ END BENTS)

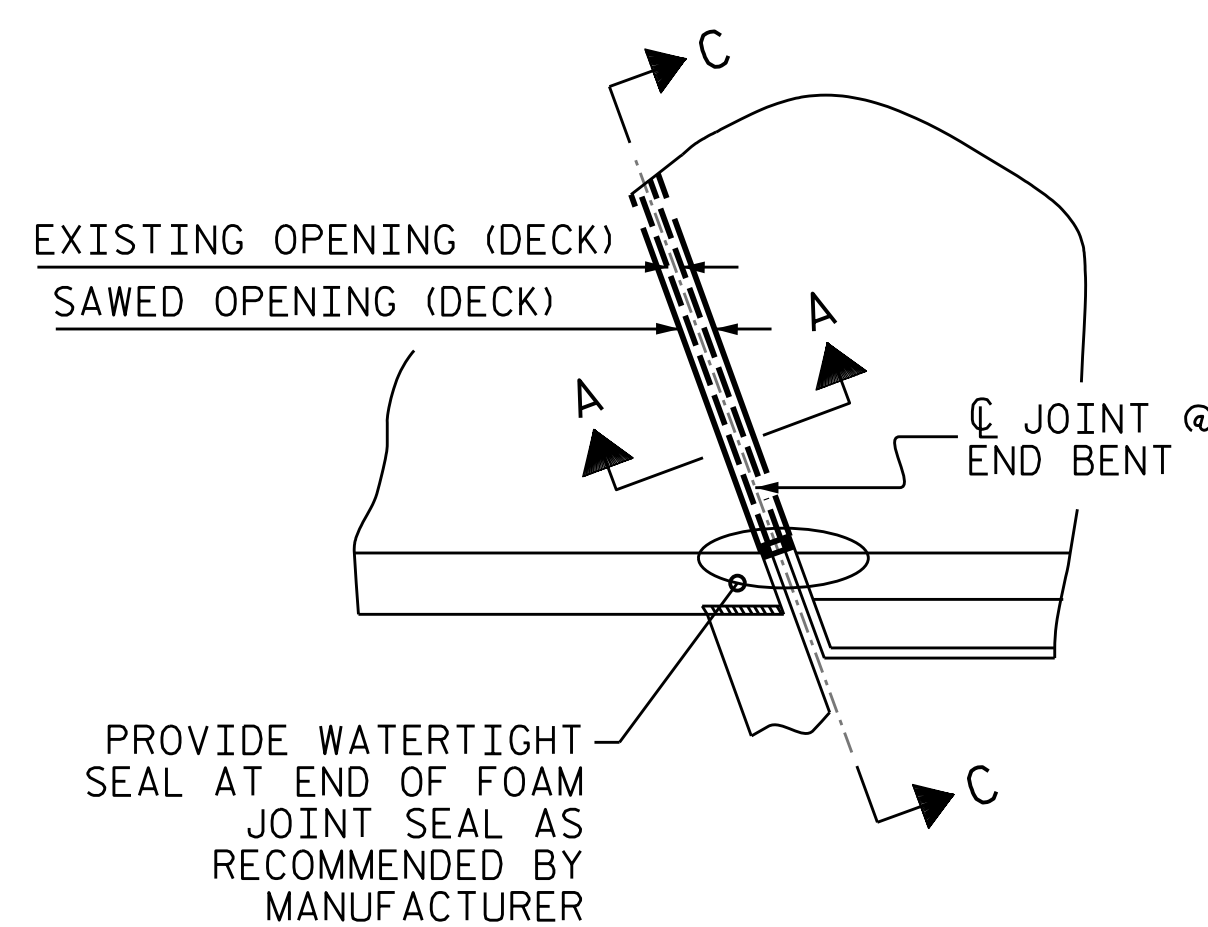

PLAN
(@ END BENTS)

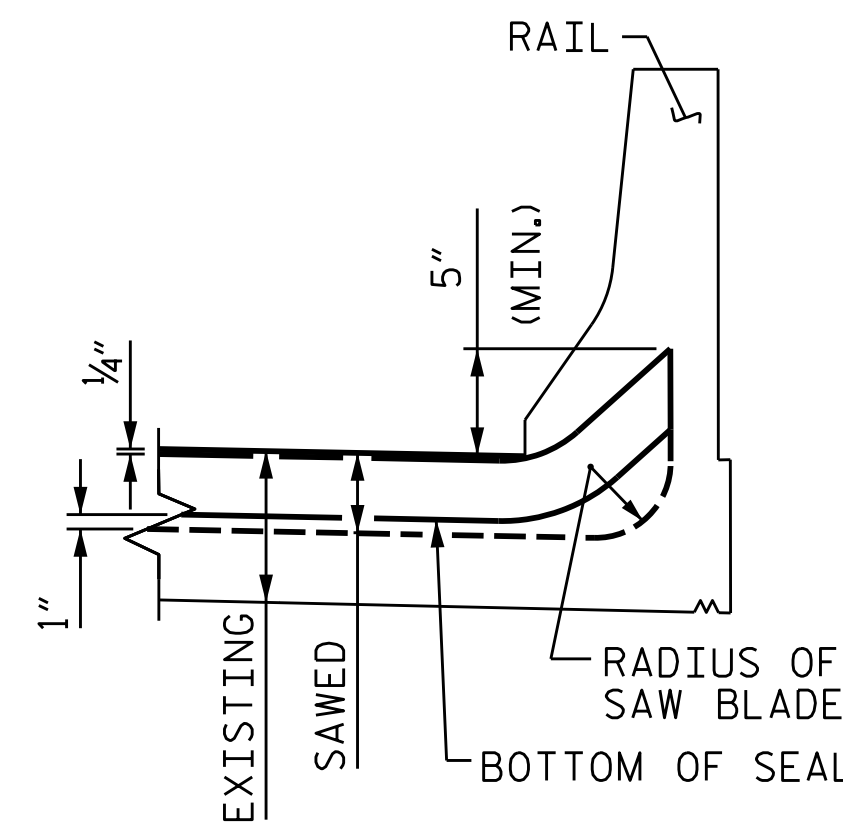

SECTION C-C

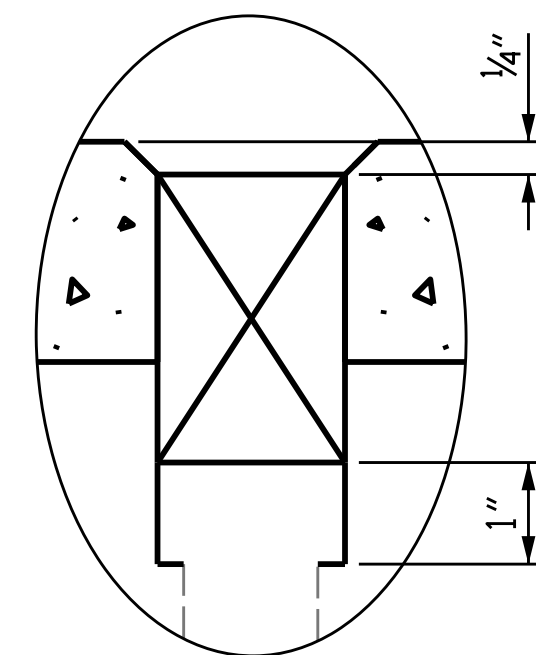

DETAIL 'A'

SAWED JOINT OPENING TABLE

LOCATION	SAWED JT. OPENING (PERPENDICULAR TO JT.)		
	AT 45°	AT 60°	AT 90°
END BENT 1	1 5/8"	1 1/16"	1 3/8"
END BENT 2	1 5/8"	1 1/16"	1 3/8"

ELASTOMERIC CONCRETE FOR PRESERVATION

LOCATION	ESTIMATED (CU.FT.)	ACTUAL (CU.FT.)
END BENT 1	10.6	
END BENT 2	10.5	
TOTAL	21.1	

JOINT REPAIR QUANTITY TABLE

	ESTIMATED	ACTUAL
FOAM JOINT SEALS FOR PRESERVATION	87.3 FT.	

BRIDGE JOINT DEMOLITION

LOCATION	ESTIMATED (SQ.FT.)	ACTUAL (SQ.FT.)
END BENT 1	42.4	
END BENT 2	42.0	
TOTAL	84.2	

ASSEMBLED BY : A.M. LEE DATE : 2/2022
 CHECKED BY : E. BAYISSA DATE : 2/2022
 DRAWN BY : NAP 08/2018
 CHECKED BY : -

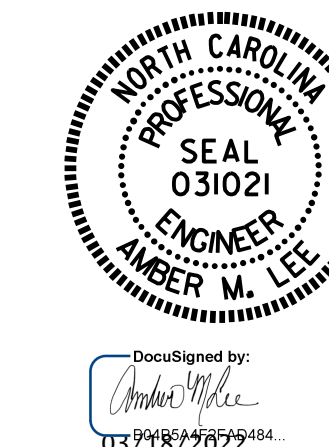

STATE OF NORTH CAROLINA
 DEPARTMENT OF TRANSPORTATION
 RALEIGH
 STANDARDS
FOAM JOINT SEALS FOR PRESERVATION DETAILS

NO.	REVISIONS			SHEET NO.
	BY:	DATE:	NO.	
1			3	S1-06 TOTAL SHEETS 6
2			4	

DOCUMENT NOT CONSIDERED FINAL UNLESS ALL SIGNATURES COMPLETED