

BILL OF MATERIAL

FOR ONE CURB ON APPROACH SLAB 2

BAR	NO.	SIZE	TYPE	LENGHT	WEIGHT
*B1	1	4	STR	10'-7"	7
*D1	8	4	STR	0'-10"	5
*EPOXY COATED REINFORCING STEEL				LBS.	12
CLASS AA CONCRETE				CU. YDS.	0.2

NOTES

REPAIR LOCATIONS AND ESTIMATED QUANTITIES ARE BASED ON THE BEST INFORMATION AVAILABLE. IF ADDITIONAL REPAIRS NOT SHOWN ON THE DRAWINGS ARE DEEMED NECESSARY BY THE ENGINEER, THE ENGINEER WILL NOTE ON THE DRAWINGS THE APPROXIMATE LOCATIONS AND DESCRIPTION OF THE REPAIRS AND ENTER THE ACTUAL QUANTITIES INTO THE AS-BUILT REPAIR QUANTITY TABLE.



PAYMENT FOR CLASS II SURFACE PREPARATION IS BASED ON THE SQUARE YARDS OF ADDITIONAL DEMOLITION REQUIRED FOLLOWING HYDRO-DEMOLITION OF THE BRIDGE DECK. SEE SPECIAL PROVISIONS.

FOR SECTION A-A, SEE FOAM JOINT DETAIL SHEET.

FOR LMC-ES OVERLAY, SEE SPECIAL PROVISIONS.

FOR BRIDGE JOINT DEMOLITION, SEE SPECIAL PROVISIONS.

FOR CURB REPAIR, SEE SPECIAL PROVISIONS.

-  CLASS II SURFACE PREPARATION
-  BRIDGE JOINT DEMOLITION

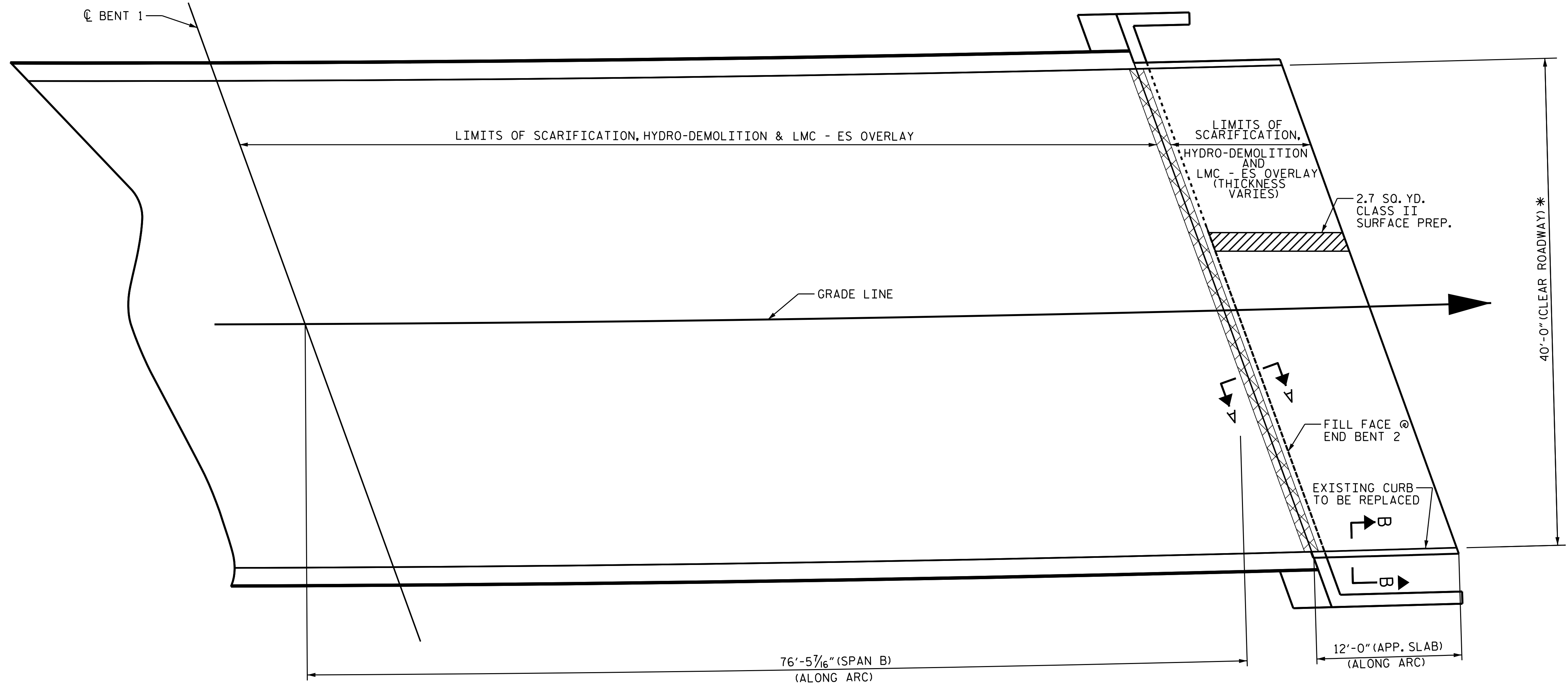

SPAN B *RADIAL DIMENSION

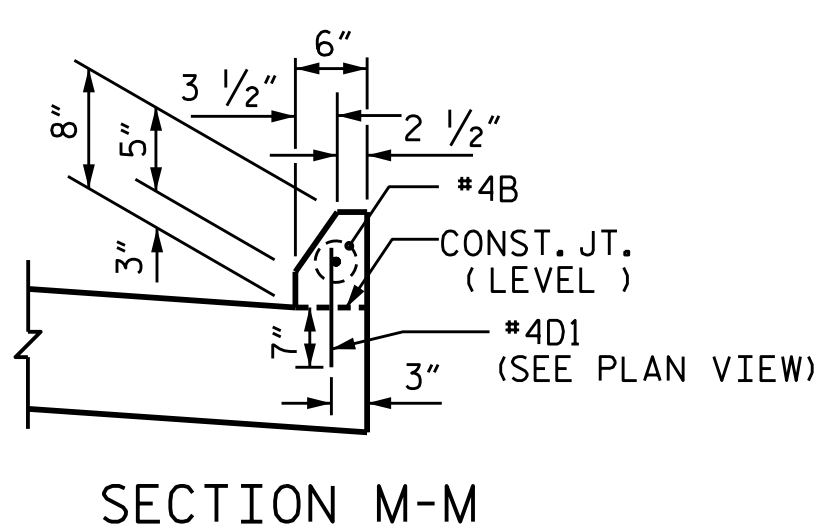

SECTION M-M

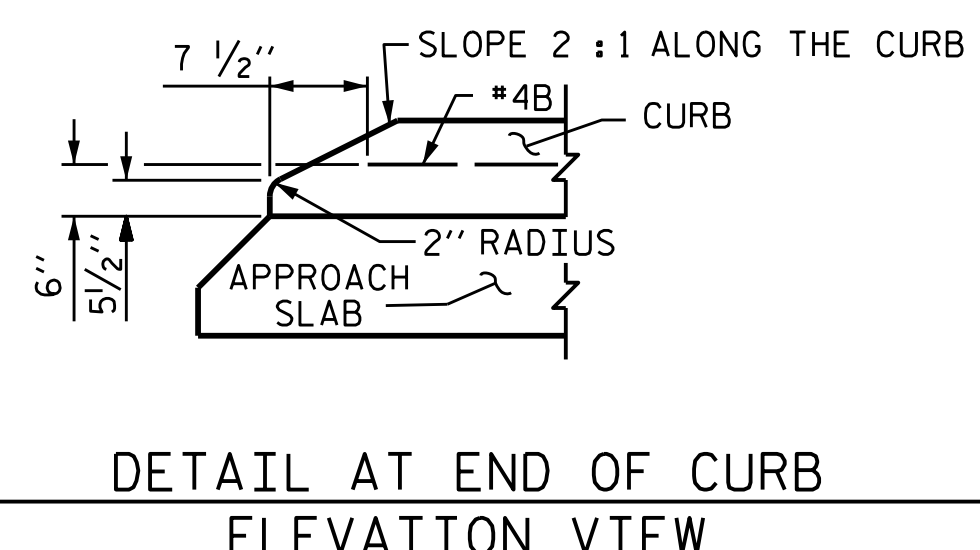

DETAIL AT END OF CURB
ELEVATION VIEW

THE JOINT REPLACEMENT SHALL BE COMPLETED PRIOR TO THE PLACING OF DOWELS OR CASTING OF THE CONCRETE CURB.

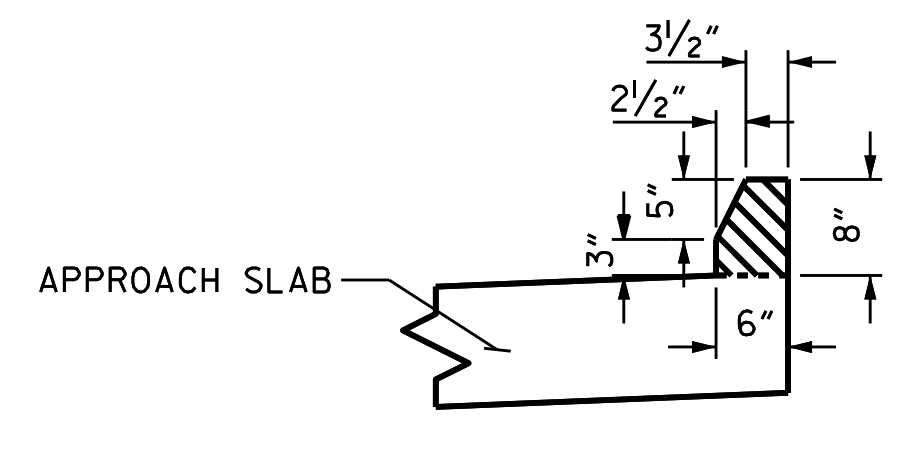

SECTION B-B
CURB ON APPROACH SLAB

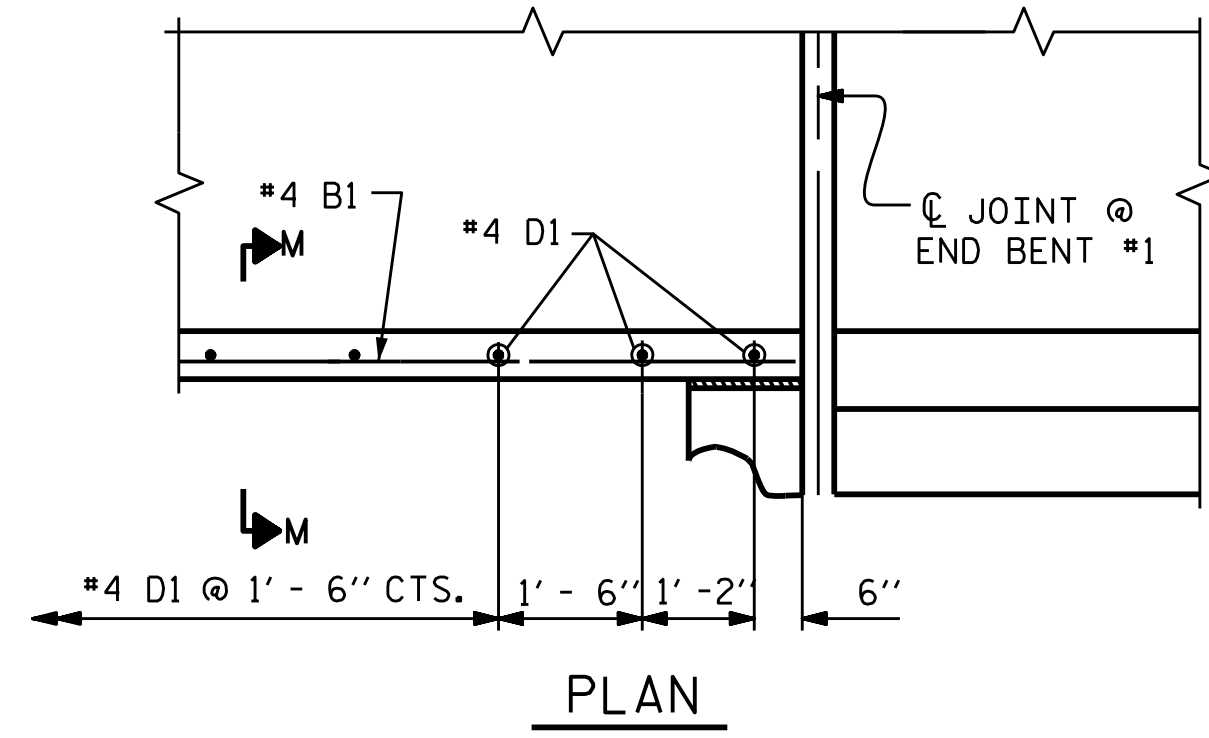

PLAN

CURB REPAIR

AS-BUILT REPAIR QUANTITY TABLE

DECK SURFACE REPAIRS - APPROACH SLAB 2			DECK SURFACE REPAIRS - SPAN B		
	ESTIMATE	ACTUAL		ESTIMATE	ACTUAL
CLASS II SURFACE PREPARATION	2.7 SQ. YDS.		CLASS II SURFACE PREPARATION	0.0 SQ. YDS.	
LATEX MODIFIED CONCRETE - ES	3.2 CU. YDS.		LATEX MODIFIED CONCRETE - ES	21.1 CU. YDS.	
PLACING AND FINISHING LMC OVERLAY	50.5 SQ. YDS.		PLACING AND FINISHING LMC OVERLAY	338.0 SQ. YDS.	
SCARIFYING BRIDGE DECK	50.5 SQ. YDS.		SCARIFYING BRIDGE DECK	338.0 SQ. YDS.	
HYDRO-DEMOLITION OF BRIDGE DECK	50.5 SQ. YDS.		HYDRO-DEMOLITION OF BRIDGE DECK	338.0 SQ. YDS.	
GROOVING BRIDGE FLOORS	423.0 SQ. FT.		GROOVING BRIDGE FLOORS	2807.0 SQ. FT.	
CURB REPAIR	12.0 LN. FT.				

PROJECT NO. I-5831A
MADISON COUNTY
 BRIDGE NO. 560540

SHEET 2 OF 2

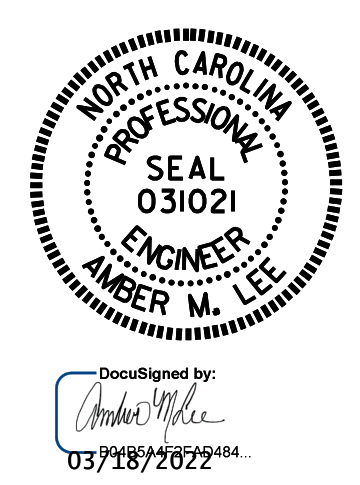

STATE OF NORTH CAROLINA
 DEPARTMENT OF TRANSPORTATION
 RALEIGH

DECK SURFACE REPAIR
 APPROACH SLAB 2
 & SPAN B

DRAWN BY : C. RUIZ DATE : 05/2019
 CHECKED BY : E. BAYISSA DATE : 02/2022

DOCUMENT NOT CONSIDERED
 FINAL UNLESS ALL
 SIGNATURES COMPLETED

REVISIONS						SHEET NO.
NO.	BY:	DATE:	NO.	BY:	DATE:	S1-05
1			3			TOTAL SHEETS
2			4			6