

TIP PROJECT: R-2511

CONTRACT: C204498

**STATE OF NORTH CAROLINA
DEPARTMENT OF TRANSPORTATION**

**PAVEMENT MARKING PLAN
BEAUFORT AND MARTIN COUNTIES**

**LOCATION: US 17 FROM NORTH OF NC 171 TO
EXISTING MULTI-LANES SOUTH OF WILLIAMSTON**

<small>TIP NO.</small> R-2511	<small>SHEET NO.</small> PMP-1
<small>DocuSigned by:</small> <i>Kevin Bishop</i> <small>80040262812474</small>	
<small>APPROVED:</small>	
<small>DATE:</small> 1/26/2022	
	
DOCUMENT NOT CONSIDERED FINAL UNLESS ALL SIGNATURES COMPLETED	

INDEX

<u>SHEET NO.</u>	<u>DESCRIPTION</u>
PMP-1	PAVEMENT MARKING PLAN TITLE SHEET, APPLICABLE ROADWAY STD. DWGS., AND GENERAL NOTES
PMP-1A	DETAILS TO BE USED IN LIEU OF 2018 STANDARD DETAILS
PMP-2 THROUGH PMP-33	PAVEMENT MARKING DETAIL

ROADWAY STANDARD DRAWINGS

THE FOLLOWING ROADWAY STANDARDS AS APPEAR IN "ROADWAY STANDARD DRAWINGS" - N.C. DEPARTMENT OF TRANSPORTATION - RALEIGH, N.C., DATED JANUARY 2018 ARE APPLICABLE TO THIS PROJECT AND BY REFERENCE HEREBY ARE CONSIDERED A PART OF THESE PLANS:

<u>STD. NO.</u>	<u>TITLE</u>
1205.01	PAVEMENT MARKINGS - LINE TYPES AND OFFSETS
1205.02	PAVEMENT MARKINGS - TWO-LANE AND MULTI-LANE ROADWAYS
1205.04	PAVEMENT MARKINGS - INTERSECTIONS
1205.05	PAVEMENT MARKINGS - TURN LANES
1205.08	PAVEMENT MARKINGS - SYMBOLS AND WORD MESSAGES
1205.09	PAVEMENT MARKINGS - PAINTED ISLANDS
1205.12	PAVEMENT MARKINGS - BRIDGES
1205.15	PAVEMENT MARKINGS - SUPERSTREETS
1250.01	RAISED PAVEMENT MARKERS - INSTALLATION SPACING
1251.01	RAISED PAVEMENT MARKERS - PERMANENT AND TEMPORARY
1253.01	RAISED PAVEMENT MARKERS - SNOWPLOWABLE
1261.01	GUARDRAIL AND BARRIER DELINEATORS - INSTALLATION SPACING
1261.02	GUARDRAIL AND BARRIER DELINEATORS - TYPES AND MOUNTING
1262.01	GUARDRAIL END DELINEATION

GENERAL NOTES

THE FOLLOWING GENERAL NOTES APPLY AT ALL TIMES FOR THE DURATION OF THE CONSTRUCTION PROJECT, EXCEPT WHEN OTHERWISE NOTED IN THE PLAN, OR DIRECTED BY THE ENGINEER.

- A. INSTALL PAVEMENT MARKINGS AND PAVEMENT MARKERS ON THE FINAL SURFACE AS FOLLOWS:
- | ROAD NAME | MARKING | MARKER |
|-------------------|---------------|----------------------------|
| US 17 | THERMOPLASTIC | NON-CAST IRON SNOWPLOWABLE |
| -Y-LINES | THERMOPLASTIC | MATCH EXISTING |
| CONCRETE SURFACES | POLYUREA | PERMANENT RAISED |
- B. TIE PROPOSED PAVEMENT MARKING LINES TO EXISTING PAVEMENT MARKING LINES.
- C. REMOVE/REPLACE ANY CONFLICTING/DAMAGED PAVEMENT MARKINGS AND MARKERS.
- D. STOP BAR LOCATION AT NON-SIGNALIZED INTERSECTIONS MAY BE ADJUSTED AS DIRECTED BY THE ENGINEER.
- E. REMOVE ALL RESIDUE AND SURFACE LAITANCE BY ACCEPTABLE METHODS ON CONCRETE BRIDGE DECKS PRIOR TO PLACING POLYUREA PAVEMENT MARKING MATERIAL.
- F. UNLESS OTHERWISE SPECIFIED, HEATED-IN-PLACE THERMOPLASTIC MAY BE USED IN LIEU OF EXTRUDED THERMOPLASTIC FOR STOP BARS, SYMBOLS, CHARACTERS AND DIAGONALS. IF HEATED-IN-PLACE IS USED, IT SHALL BE PAID FOR USING THE EXTRUDED THERMOPLASTIC PAY ITEM.

PLAN SUBMITTED TO: N.C.D.O.T. DIVISION 1

JOHN ABEL, JR. PROJECT ENGINEER - DIVISION 1

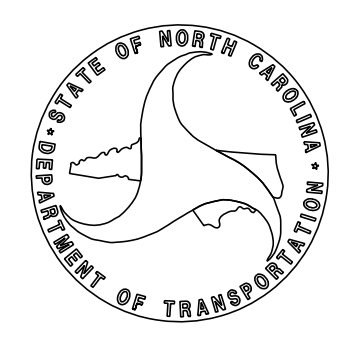

PLAN PREPARED BY: RK&K

ANUSHA POKREL ASSOCIATE ENGINEER
ALLEN TUTT SENIOR DESIGNER

RK&K
P: (919) 678-9580
8601 Six Forks Road Forum 1 Suite 700 | Raleigh, North Carolina 27615
NC License No. F-0112
www.rkk.com
Engineers | Construction Managers | Planners | Scientists
Responsive People | Creative Solutions

TIP NO. SHEET NO.
 DocuSigned by:
 APPROVED: *Matthew V. Springer*
 DATE: 8/13/2019
 SEAL

APPROVED: _____
 DATE: _____

SEAL

DOCUMENT NOT CONSIDERED FINAL
 UNLESS ALL SIGNATURES COMPLETED

STATE OF NORTH CAROLINA
 DEPT. OF TRANSPORTATION
 DIVISION OF HIGHWAYS
 RALEIGH, N.C.



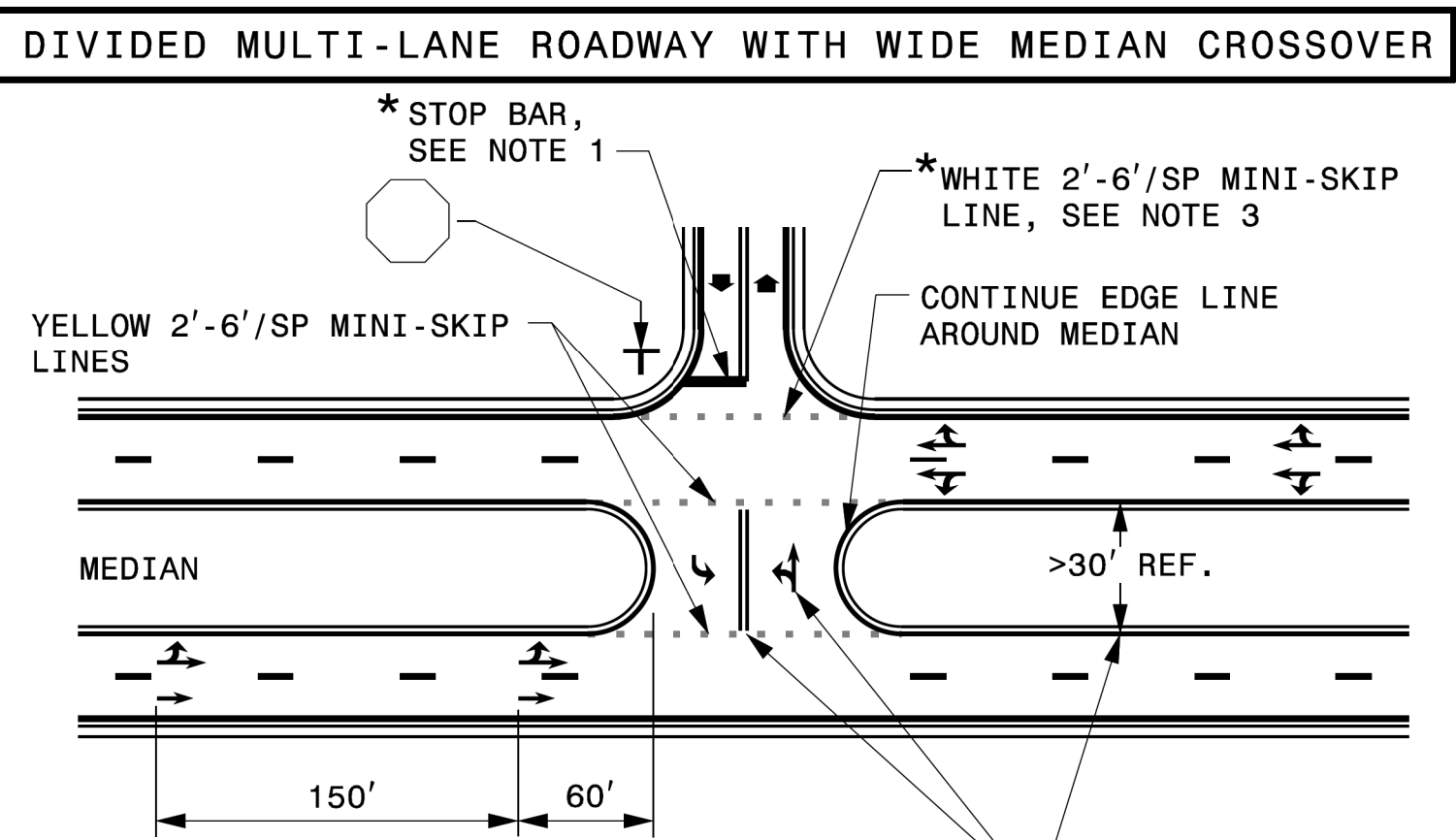
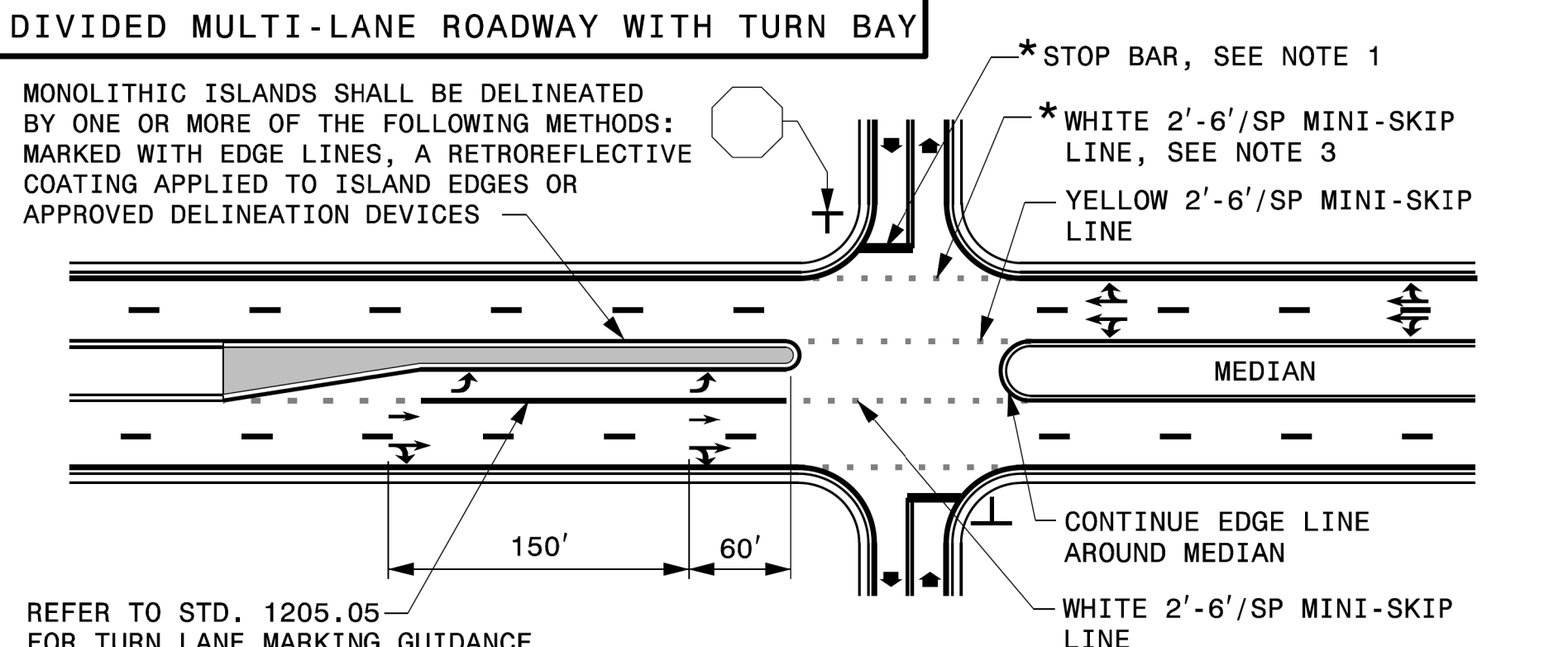
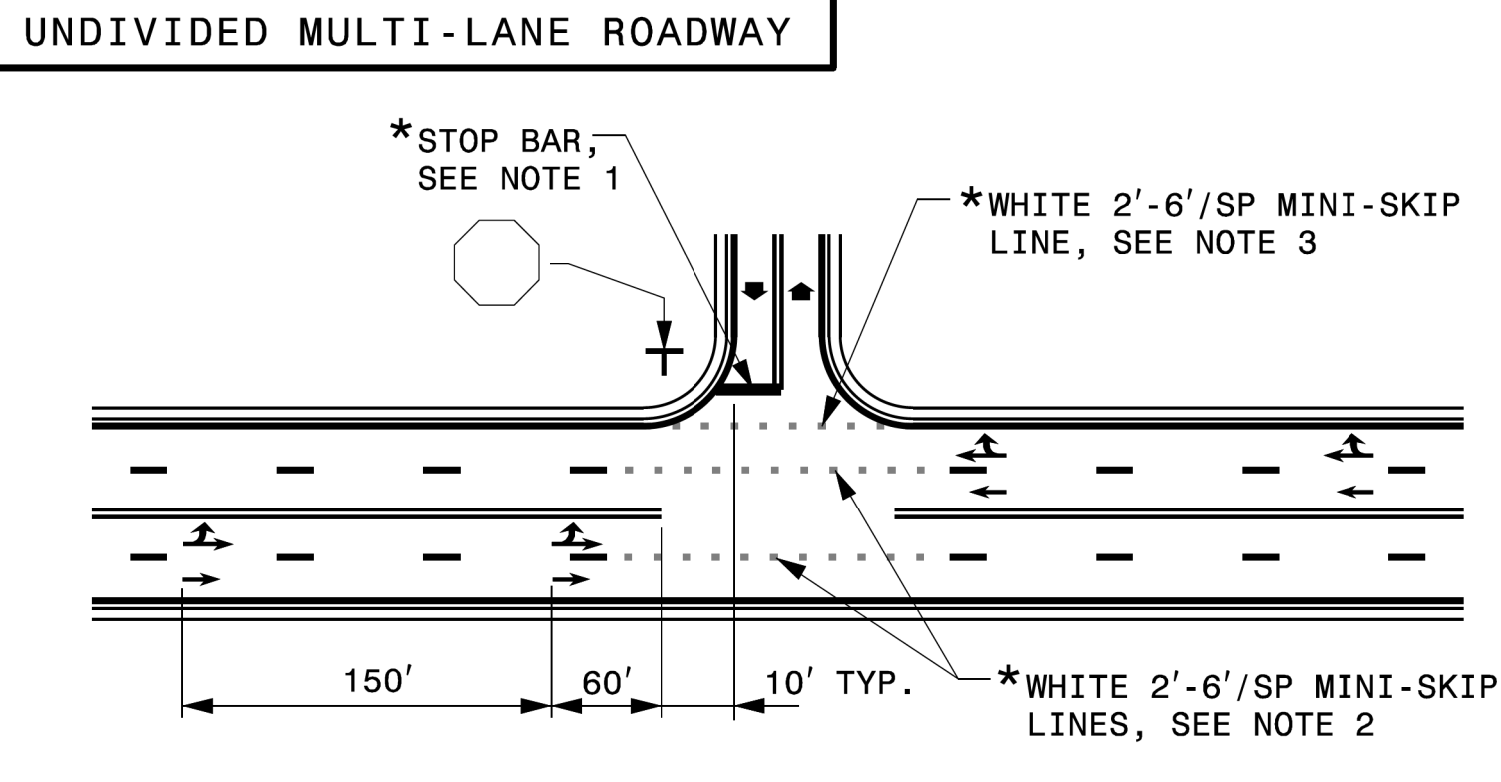
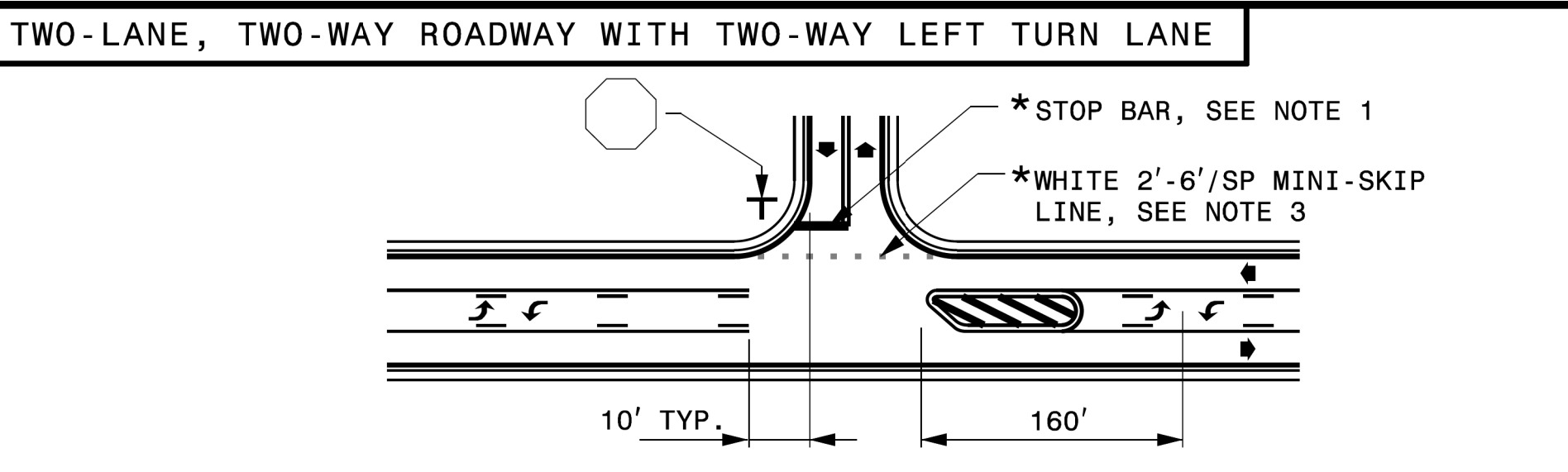
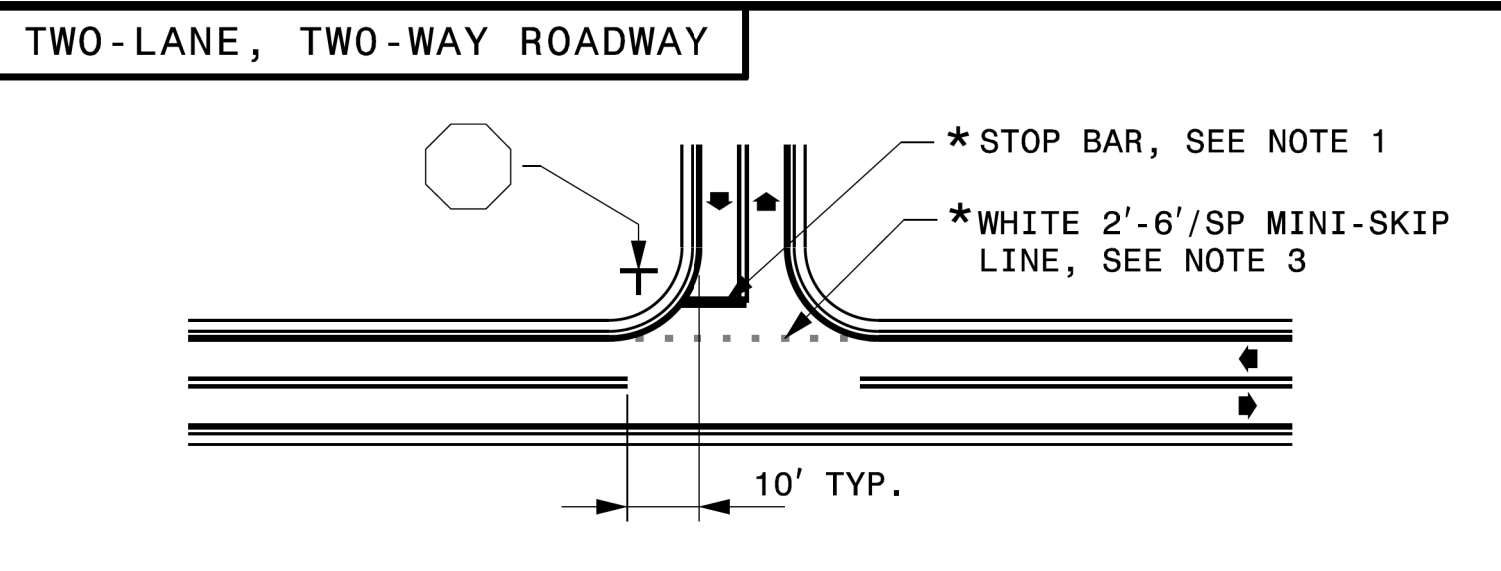

ENGLISH DETAIL DRAWING FOR
 PAVEMENT MARKINGS
 INTERSECTIONS

SHEET 2 OF 2
 1205D04



- GENERAL NOTES:
- 1- PLACEMENT OF STOP BARS AT NON-SIGNALIZED INTERSECTIONS IS OPTIONAL AND USED WHERE IT IS IMPORTANT TO INDICATE THE POINT WHICH VEHICLES ARE REQUIRED TO STOP. PLACE STOP BARS NO LESS THAN 4 FEET AND NO MORE THAN 30 FEET FROM THE NEAREST EDGE OF THE INTERSECTING ROADWAY. USE 10 FEET AS THE TYPICAL SETBACK DISTANCE OR AS DIRECTED BY THE ENGINEER.
 - 2- MINI-SKIP LANE LINE EXTENSIONS SHOULD BE USED AT INTERSECTIONS THAT HAVE REDUCED VISIBILITY CONDITIONS SUCH AS OFFSET, SKEWED, OR CURVED ROADWAYS.
 - 3- MINI-SKIP EDGE LINE EXTENSIONS MAY BE PLACED THROUGH INTERSECTIONS AND MAJOR DRIVEWAYS.
 - 4- REFER TO ROADWAY STANDARD DRAWINGS 1205.01, 1205.02, 1205.05, 1205.08 AND 1205.09 FOR ADDITIONAL PAVEMENT MARKING GUIDANCE.

LEGEND

 STOP SIGN	 STATIONARY SIGN
 DIRECTION OF TRAFFIC FLOW	 PAVEMENT MARKING SYMBOLS
* OPTIONAL	

STATE OF NORTH CAROLINA
 DEPT. OF TRANSPORTATION
 DIVISION OF HIGHWAYS
 RALEIGH, N.C.

ENGLISH DETAIL DRAWING FOR
 PAVEMENT MARKINGS
 INTERSECTIONS

SHEET 2 OF 2
 1205D04

REVISED PAVEMENT MARKING
 ROADWAY STANDARD DRAWING

RKK
 P: (919) 578-9500
 8601 Six Forks Road Forum 1 Suite 700 | Raleigh, North Carolina 27615
 NC License No. F-0112
 Engineers | Construction Managers | Planners | Scientists
 www.rkk.com
 Responsive People | Creative Solutions

DETAIL TO BE USED IN LIEU OF
 ROADWAY STANDARD DRAWING

I:\2019\1205D04_PMP_PSHIA.dgn
 8/13/2019 10:58:10 AM
 kbsb

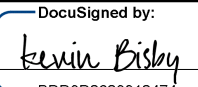
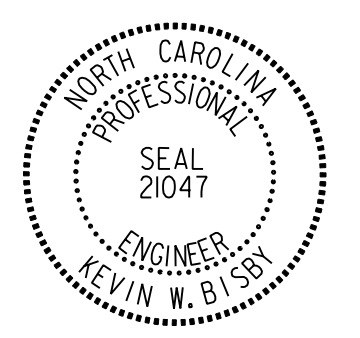
TIP NO. R-2511	SHEET NO. PMP-2
APPROVED:  DATE: 10/1/2021	
SEAL 	
DOCUMENT NOT CONSIDERED FINAL UNLESS ALL SIGNATURES COMPLETED	

PAVEMENT MARKING SCHEDULE

THERMOPLASTIC LINES (90 MILS)	THERMOPLASTIC SYMBOLS (90 MILS)
T2 WHITE STOPBAR (24")	UA LEFT TURN ARROW
T6 WHITE EDGELINE (6")	UB RIGHT TURN ARROW
T7 YELLOW EDGELINE (6")	UN 24" YIELD LINE TRIANGLE
T11 2 FT. -6 FT./SP WHITE MINISKIP (6")	UT U-TURN ARROW
T12 2 FT. -6 FT./SP YELLOW MINISKIP (6")	
TA WHITE EDGELINE (4")	
TB YELLOW EDGELINE (4")	PAVEMENT MARKERS
TI YELLOW DOUBLE CENTERLINE (4")	MA PERMANENT RAISED (YELLOW & YELLOW)
TJ 10 FT. WHITE SKIP (6")	MB PERMANENT RAISED (CRYSTAL & RED)
TK 3 FT.-9 FT./SP WHITE MINISKIP (6")	ME SNOWPLOWABLE (YELLOW & YELLOW)
TP YELLOW DIAGONAL (8")	MF SNOWPLOWABLE (CRYSTAL & RED)
TU WHITE DIAGONAL (12")	
TS WHITE GORELINE (12")	
POLYUREA LINES	
VK 3 FT.-9 FT./SP WHITE MINISKIP (6")	
V6 WHITE EDGELINE (6")	
V7 YELLOW EDGELINE (6")	
VJ 10 FT. WHITE SKIP (6")	

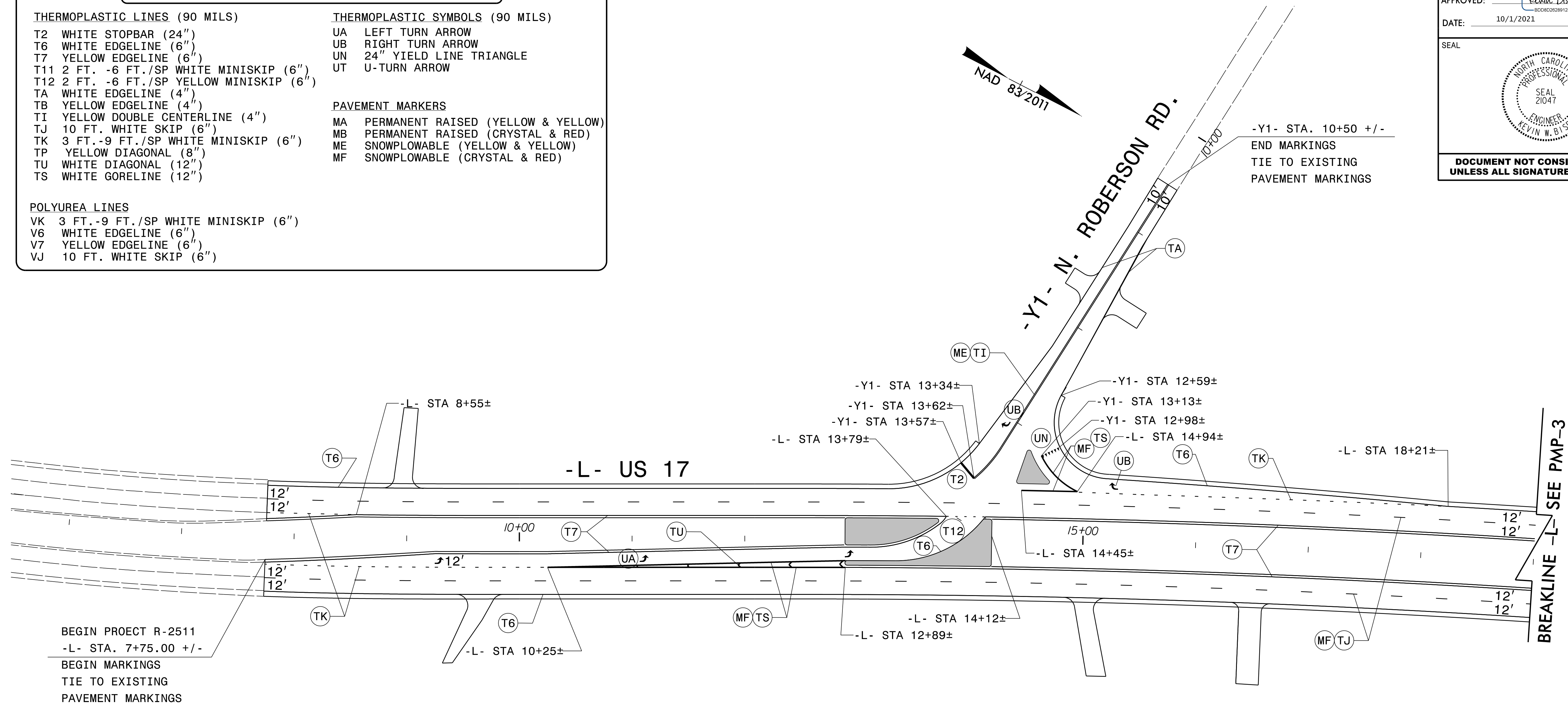

10/1/2021 10:41:11 AM PMP_PSH02.dgn

RKK
 P: (919) 578-9500
 8601 Six Forks Road Forum 1 Suite 700 | Raleigh, North Carolina 27615
 NC License No. F-0112
 Engineers | Construction Managers | Planners | Scientists
 www.rkk.com
 Responsive People | Creative Solutions

PAVEMENT MARKING SCHEDULE

THERMOPLASTIC LINES (90 MILS)

- T2 WHITE STOPBAR (24")
- T6 WHITE EDGELINE (6")
- T7 YELLOW EDGELINE (6")
- T11 2 FT. -6 FT./SP WHITE MINISKIP (6")
- T12 2 FT. -6 FT./SP YELLOW MINISKIP (6")
- TA WHITE EDGELINE (4")
- TB YELLOW EDGELINE (4")
- TI YELLOW DOUBLE CENTERLINE (4")
- TJ 10 FT. WHITE SKIP (6")
- TK 3 FT.-9 FT./SP WHITE MINISKIP (6")
- TP YELLOW DIAGONAL (8")
- TU WHITE DIAGONAL (12")
- TS WHITE GORELINE (12")

THERMOPLASTIC SYMBOLS (90 MILS)

- UA LEFT TURN ARROW
- UB RIGHT TURN ARROW
- UN 24" YIELD LINE TRIANGLE
- UT U-TURN ARROW

PAVEMENT MARKERS

- MA PERMANENT RAISED (YELLOW & YELLOW)
- MB PERMANENT RAISED (CRYSTAL & RED)
- ME SNOWPLOWABLE (YELLOW & YELLOW)
- MF SNOWPLOWABLE (CRYSTAL & RED)

POLYUREA LINES

- VK 3 FT.-9 FT./SP WHITE MINISKIP (6")
- V6 WHITE EDGELINE (6")
- V7 YELLOW EDGELINE (6")
- VJ 10 FT. WHITE SKIP (6")

NAD 83/2011

TIP NO. R-2511	SHEET NO. PMP-3
APPROVED:	
DATE: 10/1/2021	
DOCUMENT NOT CONSIDERED FINAL UNLESS ALL SIGNATURES COMPLETED	

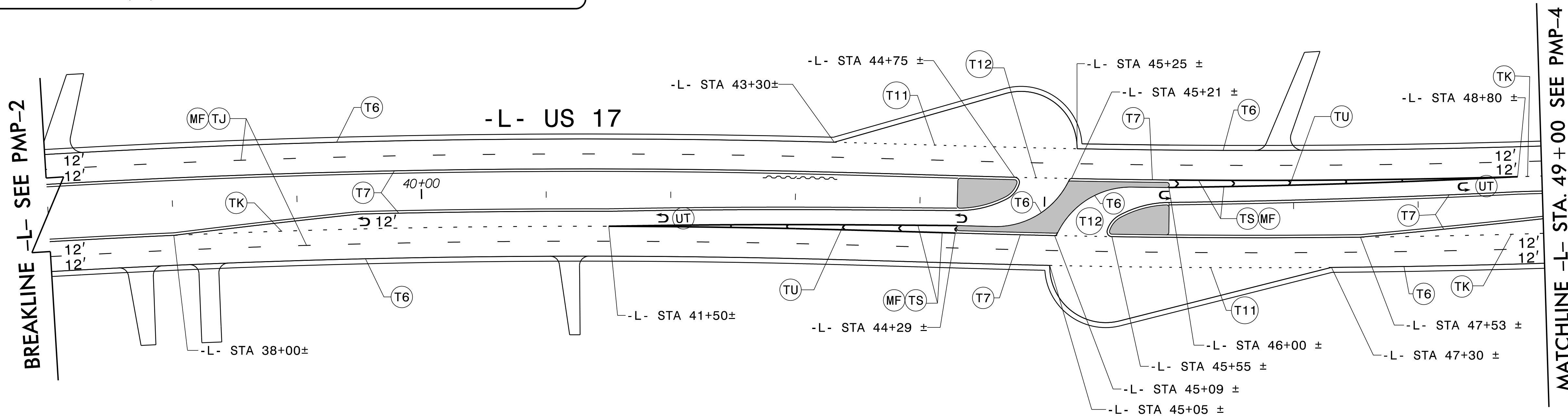

10/1/2021 10:41:11 AM PMP_PSH03.dgn

RKK
 P: (919) 578-9500
 8601 Six Forks Road Forum 1 Suite 700 | Raleigh, North Carolina 27615
 NC License No. F-0112
 Engineers | Construction Managers | Planners | Scientists
 www.rkk.com
 Responsive People | Creative Solutions

PAVEMENT MARKING DETAIL

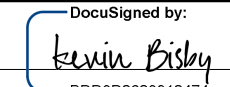
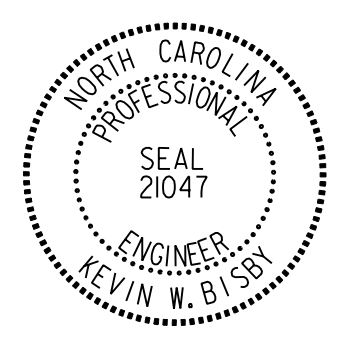
TIP NO. R-2511	SHEET NO. PMP-4
APPROVED:  DATE: 10/1/2021	
SEAL 	
DOCUMENT NOT CONSIDERED FINAL UNLESS ALL SIGNATURES COMPLETED	

PAVEMENT MARKING SCHEDULE

THERMOPLASTIC LINES (90 MILS)	THERMOPLASTIC SYMBOLS (90 MILS)
T2 WHITE STOPBAR (24")	UA LEFT TURN ARROW
T6 WHITE EDGELINE (6")	UB RIGHT TURN ARROW
T7 YELLOW EDGELINE (6")	UN 24" YIELD LINE TRIANGLE
T11 2 FT. -6 FT./SP WHITE MINISKIP (6")	UT U-TURN ARROW
T12 2 FT. -6 FT./SP YELLOW MINISKIP (6")	
TA WHITE EDGELINE (4")	
TB YELLOW EDGELINE (4")	
TI YELLOW DOUBLE CENTERLINE (4")	
TJ 10 FT. WHITE SKIP (6")	
TK 3 FT.-9 FT./SP WHITE MINISKIP (6")	
TP YELLOW DIAGONAL (8")	
TU WHITE DIAGONAL (12")	
TS WHITE GORELINE (12")	
	PAVEMENT MARKERS
	MA PERMANENT RAISED (YELLOW & YELLOW)
	MB PERMANENT RAISED (CRYSTAL & RED)
	ME SNOWPLOWABLE (YELLOW & YELLOW)
	MF SNOWPLOWABLE (CRYSTAL & RED)
POLYUREA LINES	
VK 3 FT.-9 FT./SP WHITE MINISKIP (6")	
V6 WHITE EDGELINE (6")	
V7 YELLOW EDGELINE (6")	
VJ 10 FT. WHITE SKIP (6")	

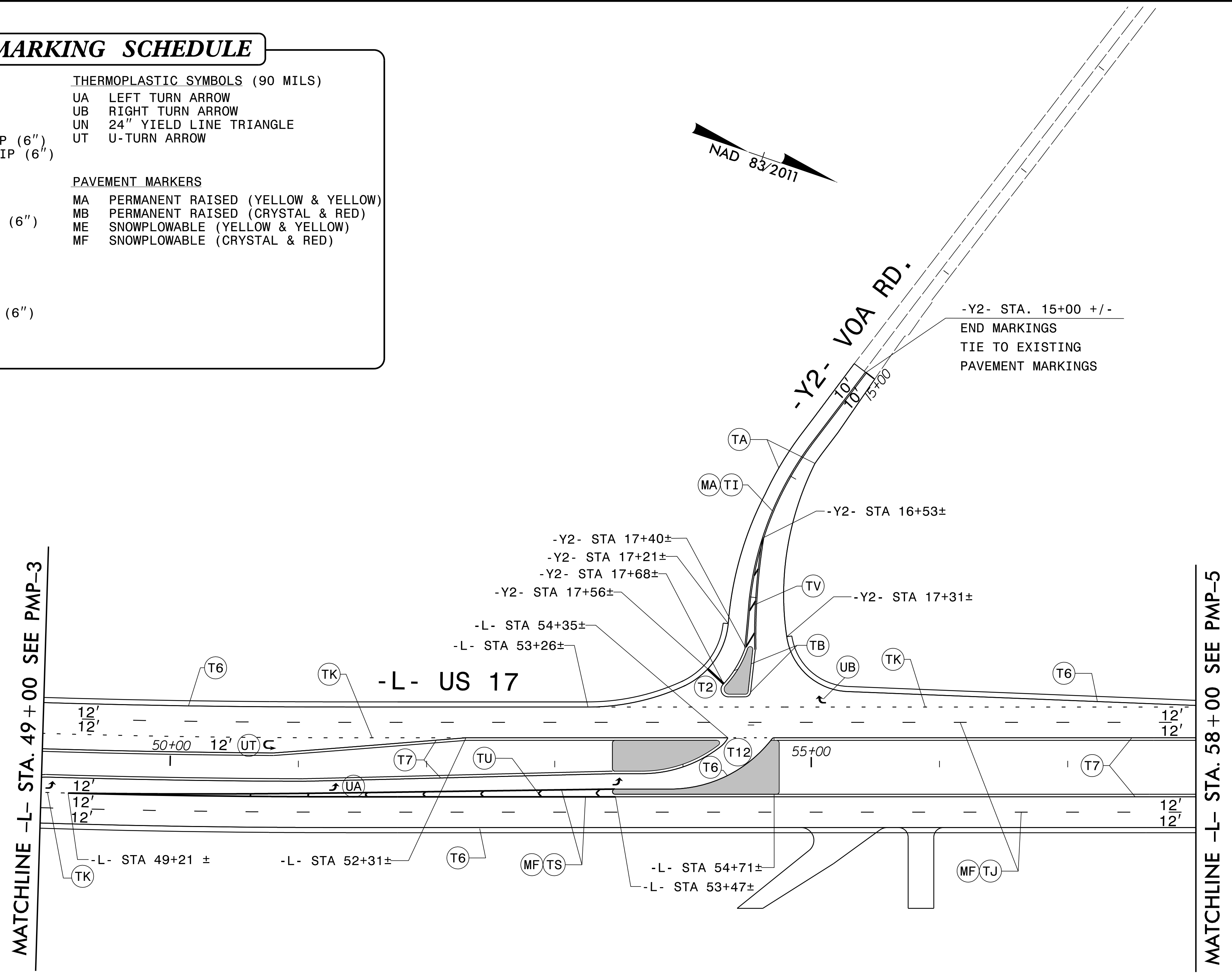

10/1/2021
PLAN PMP_PSH04.dgn
kbs

RKK
P: (919) 578-9500
8601 Six Forks Road Forum 1 Suite 700 | Raleigh, North Carolina 27615
NC License No. F-0112
Engineers | Construction Managers | Planners | Scientists
www.rkk.com
Responsive People | Creative Solutions

PAVEMENT MARKING SCHEDULE

THERMOPLASTIC LINES (90 MILS)

- T2 WHITE STOPBAR (24")
- T6 WHITE EDGELINE (6")
- T7 YELLOW EDGELINE (6")
- T11 2 FT. -6 FT./SP WHITE MINISKIP (6")
- T12 2 FT. -6 FT./SP YELLOW MINISKIP (6")
- TA WHITE EDGELINE (4")
- TB YELLOW EDGELINE (4")
- TI YELLOW DOUBLE CENTERLINE (4")
- TJ 10 FT. WHITE SKIP (6")
- TK 3 FT.-9 FT./SP WHITE MINISKIP (6")
- TP YELLOW DIAGONAL (8")
- TU WHITE DIAGONAL (12")
- TS WHITE GORELINE (12")

THERMOPLASTIC SYMBOLS (90 MILS)

- UA LEFT TURN ARROW
- UB RIGHT TURN ARROW
- UN 24" YIELD LINE TRIANGLE
- UT U-TURN ARROW

PAVEMENT MARKERS

- MA PERMANENT RAISED (YELLOW & YELLOW)
- MB PERMANENT RAISED (CRYSTAL & RED)
- ME SNOWPLOWABLE (YELLOW & YELLOW)
- MF SNOWPLOWABLE (CRYSTAL & RED)

POLYUREA LINES

- VK 3 FT.-9 FT./SP WHITE MINISKIP (6")
- V6 WHITE EDGELINE (6")
- V7 YELLOW EDGELINE (6")
- VJ 10 FT. WHITE SKIP (6")

TIP NO. R-2511	SHEET NO. PMP-5
<small>DocuSigned by:</small> <small>BOOR02028912472</small>	
APPROVED:	
DATE: 10/1/2021	
DOCUMENT NOT CONSIDERED FINAL UNLESS ALL SIGNATURES COMPLETED	

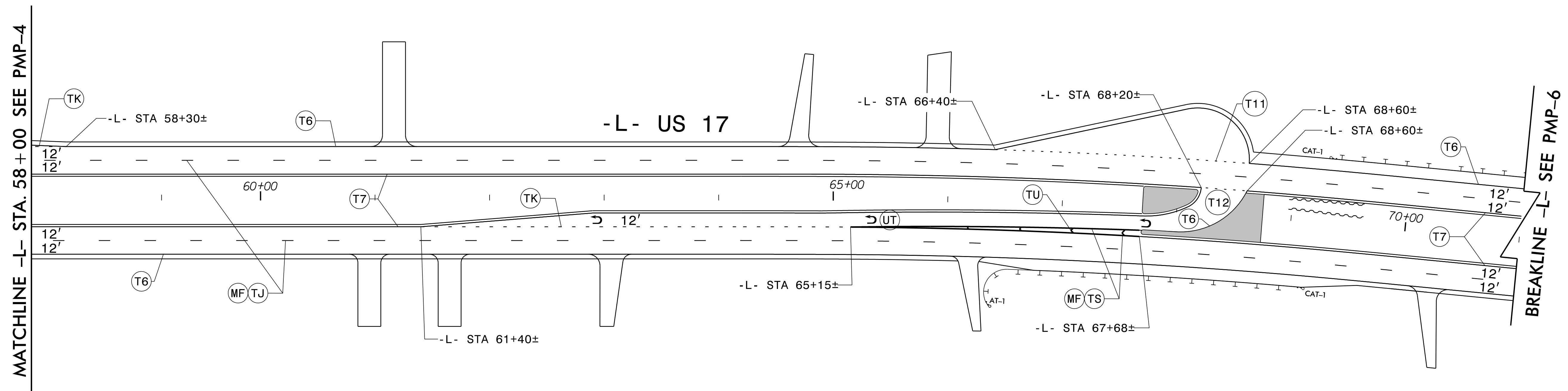

10/1/2021 10:51:00 AM PMP_PSH05.dgn

RKK
 P: (919) 578-9500
 8601 Six Forks Road Forum 1 Suite 700 | Raleigh, North Carolina 27615
 NC License No. F-0112
 Engineers | Construction Managers | Planners | Scientists
 www.rkk.com
 Responsive People | Creative Solutions

PAVEMENT MARKING DETAIL

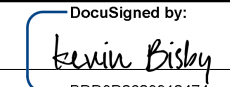
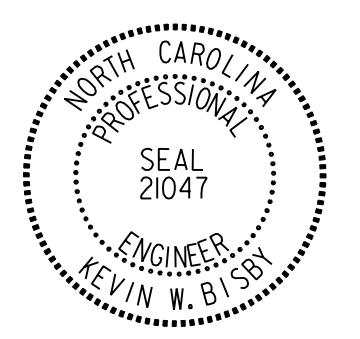
TIP NO. R-2511	SHEET NO. PMP-6
APPROVED:  DATE: 10/1/2021	
SEAL 	
DOCUMENT NOT CONSIDERED FINAL UNLESS ALL SIGNATURES COMPLETED	

PAVEMENT MARKING SCHEDULE

THERMOPLASTIC LINES (90 MILS)	THERMOPLASTIC SYMBOLS (90 MILS)
T2 WHITE STOPBAR (24")	UA LEFT TURN ARROW
T6 WHITE EDGELINE (6")	UB RIGHT TURN ARROW
T7 YELLOW EDGELINE (6")	UN 24" YIELD LINE TRIANGLE
T11 2 FT. -6 FT./SP WHITE MINISKIP (6")	UT U-TURN ARROW
T12 2 FT. -6 FT./SP YELLOW MINISKIP (6")	
TA WHITE EDGELINE (4")	
TB YELLOW EDGELINE (4")	PAVEMENT MARKERS
TI YELLOW DOUBLE CENTERLINE (4")	MA PERMANENT RAISED (YELLOW & YELLOW)
TJ 10 FT. WHITE SKIP (6")	MB PERMANENT RAISED (CRYSTAL & RED)
TK 3 FT.-9 FT./SP WHITE MINISKIP (6")	ME SNOWPLOWABLE (YELLOW & YELLOW)
TP YELLOW DIAGONAL (8")	MF SNOWPLOWABLE (CRYSTAL & RED)
TU WHITE DIAGONAL (12")	
TS WHITE GORELINE (12")	
POLYUREA LINES	
VK 3 FT.-9 FT./SP WHITE MINISKIP (6")	
V6 WHITE EDGELINE (6")	
V7 YELLOW EDGELINE (6")	
VJ 10 FT. WHITE SKIP (6")	

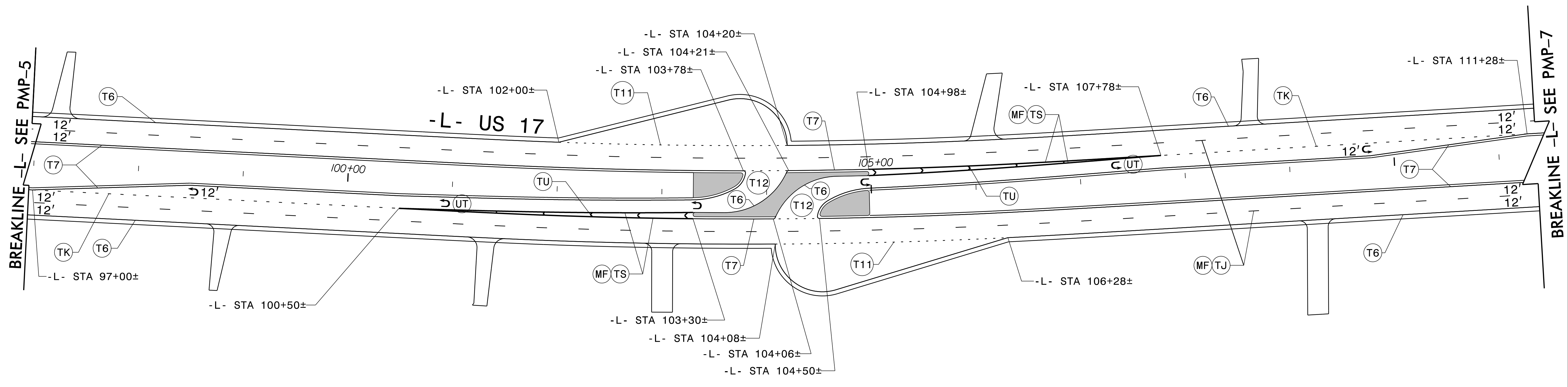

10/1/2021
D:\C\Projects\PMP_PSH06.dgn
k.bly

RKK
P: (919) 578-9500
8601 Six Forks Road Forum 1 Suite 700 | Raleigh, North Carolina 27615
NC License No. F-0112
www.rkk.com
Responsive People | Creative Solutions

PAVEMENT MARKING DETAIL

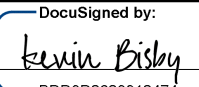
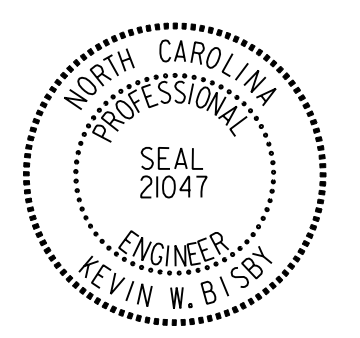
TIP NO. R-2511	SHEET NO. PMP-7
APPROVED:  <small>DocuSigned by: Kevin E. Bly B00802628912472</small>	
DATE: 10/1/2021	
SEAL 	
DOCUMENT NOT CONSIDERED FINAL UNLESS ALL SIGNATURES COMPLETED	

PAVEMENT MARKING SCHEDULE

THERMOPLASTIC LINES (90 MILS)	THERMOPLASTIC SYMBOLS (90 MILS)
T2 WHITE STOPBAR (24")	UA LEFT TURN ARROW
T6 WHITE EDGELINE (6")	UB RIGHT TURN ARROW
T7 YELLOW EDGELINE (6")	UN 24" YIELD LINE TRIANGLE
T11 2 FT. -6 FT./SP WHITE MINISKIP (6")	UT U-TURN ARROW
T12 2 FT. -6 FT./SP YELLOW MINISKIP (6")	
TA WHITE EDGELINE (4")	
TB YELLOW EDGELINE (4")	PAVEMENT MARKERS
TI YELLOW DOUBLE CENTERLINE (4")	MA PERMANENT RAISED (YELLOW & YELLOW)
TJ 10 FT. WHITE SKIP (6")	MB PERMANENT RAISED (CRYSTAL & RED)
TK 3 FT.-9 FT./SP WHITE MINISKIP (6")	ME SNOWPLOWABLE (YELLOW & YELLOW)
TP YELLOW DIAGONAL (8")	MF SNOWPLOWABLE (CRYSTAL & RED)
TU WHITE DIAGONAL (12")	
TS WHITE GORELINE (12")	
POLYUREA LINES	
VK 3 FT.-9 FT./SP WHITE MINISKIP (6")	
V6 WHITE EDGELINE (6")	
V7 YELLOW EDGELINE (6")	
VJ 10 FT. WHITE SKIP (6")	

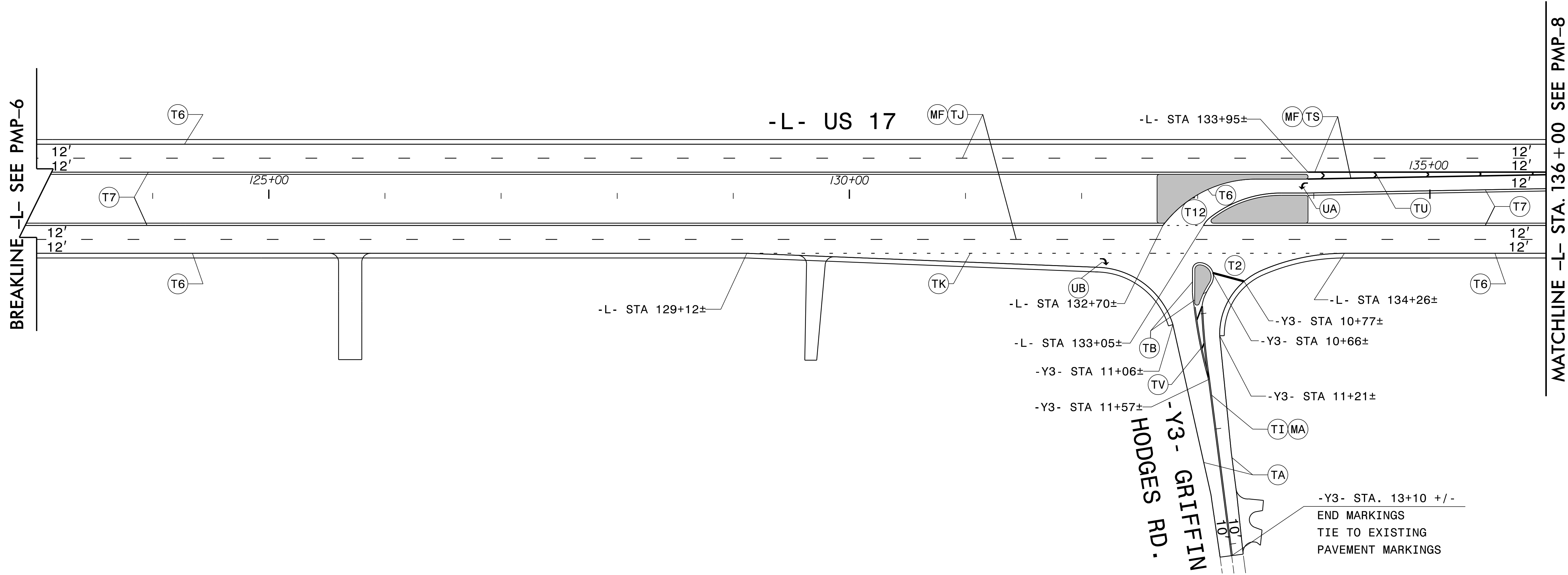

I:\2021\2021_PMP_PSH07.dgn
 Kevin E. Bly

RKK
 P: (919) 578-9500
 8601 Six Forks Road Forum 1 Suite 700 | Raleigh, North Carolina 27615
 NC License No. F-0112
 Engineers | Construction Managers | Planners | Scientists
 www.rkk.com
 Responsive People | Creative Solutions

PAVEMENT MARKING DETAIL

TIP NO. R-2511	SHEET NO. PMP-8
APPROVED: <i>Kevin Bisy</i> DATE: 10/1/2021	
SEAL 	
DOCUMENT NOT CONSIDERED FINAL UNLESS ALL SIGNATURES COMPLETED	

PAVEMENT MARKING SCHEDULE

THERMOPLASTIC LINES (90 MILS)

- T2 WHITE STOPBAR (24")
- T6 WHITE EDGELINE (6")
- T7 YELLOW EDGELINE (6")
- T11 2 FT. -6 FT./SP WHITE MINISKIP (6")
- T12 2 FT. -6 FT./SP YELLOW MINISKIP (6")
- TA WHITE EDGELINE (4")
- TB YELLOW EDGELINE (4")
- TI YELLOW DOUBLE CENTERLINE (4")
- TJ 10 FT. WHITE SKIP (6")
- TK 3 FT.-9 FT./SP WHITE MINISKIP (6")
- TP YELLOW DIAGONAL (8")
- TU WHITE DIAGONAL (12")
- TS WHITE GORELINE (12")

THERMOPLASTIC SYMBOLS (90 MILS)

- UA LEFT TURN ARROW
- UB RIGHT TURN ARROW
- UN 24" YIELD LINE TRIANGLE
- UT U-TURN ARROW

PAVEMENT MARKERS

- MA PERMANENT RAISED (YELLOW & YELLOW)
- MB PERMANENT RAISED (CRYSTAL & RED)
- ME SNOWPLOWABLE (YELLOW & YELLOW)
- MF SNOWPLOWABLE (CRYSTAL & RED)

POLYUREA LINES

- VK 3 FT.-9 FT./SP WHITE MINISKIP (6")
- V6 WHITE EDGELINE (6")
- V7 YELLOW EDGELINE (6")
- VJ 10 FT. WHITE SKIP (6")

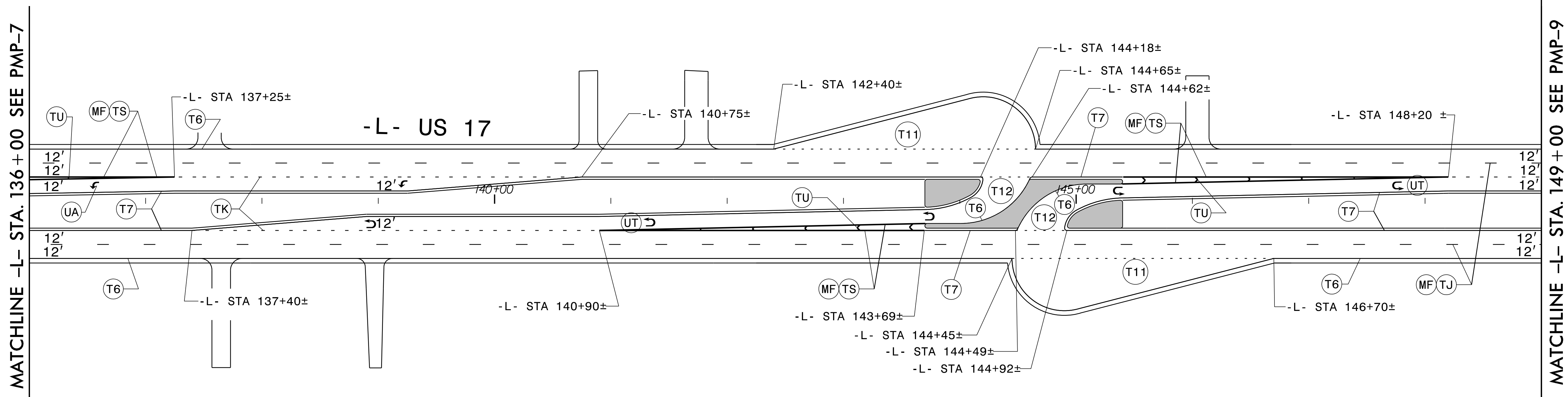
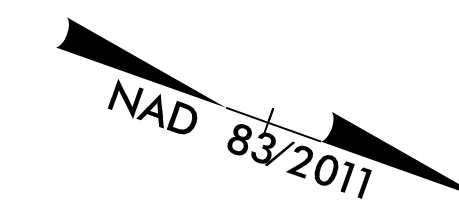

I:\A\2021\10\1\2021_PMP_PSH08.dgn

RKK
 P: (919) 578-9500
 8601 Six Forks Road Forum 1 Suite 700 | Raleigh, North Carolina 27615
 NC License No. F-0112
 Engineers | Construction Managers | Planners | Scientists
 www.rkk.com
 Responsive People | Creative Solutions

TIP NO.	SHEET NO.
R-2511	PMP-9
APPROVED:	DocuSigned by: <i>Kennix Easley</i> B00802028912472
DATE:	10/1/2021
SEAL	
DOCUMENT NOT CONSIDERED FINAL UNLESS ALL SIGNATURES COMPLETED	

PAVEMENT MARKING SCHEDULE

THERMOPLASTIC LINES (90 MILS)

- T2 WHITE STOPBAR (24")
- T6 WHITE EDGELINE (6")
- T7 YELLOW EDGELINE (6")
- T11 2 FT. -6 FT./SP WHITE MINISKIP (6")
- T12 2 FT. -6 FT./SP YELLOW MINISKIP (6")
- TA WHITE EDGELINE (4")
- TB YELLOW EDGELINE (4")
- TI YELLOW DOUBLE CENTERLINE (4")
- TJ 10 FT. WHITE SKIP (6")
- TK 3 FT. -9 FT./SP WHITE MINISKIP (6")
- TP YELLOW DIAGONAL (8")
- TU WHITE DIAGONAL (12")
- TS WHITE GORELINE (12")

THERMOPLASTIC SYMBOLS (90 MILS)

- UA LEFT TURN ARROW
- UB RIGHT TURN ARROW
- UN 24" YIELD LINE TRIANGLE
- UT U-TURN ARROW

PAVEMENT MARKERS

- MA PERMANENT RAISED (YELLOW & YELLOW)
- MB PERMANENT RAISED (CRYSTAL & RED)
- ME SNOWPLOWABLE (YELLOW & YELLOW)
- MF SNOWPLOWABLE (CRYSTAL & RED)

POLYUREA LINES

- VK 3 FT. -9 FT./SP WHITE MINISKIP (6")
- V6 WHITE EDGELINE (6")
- V7 YELLOW EDGELINE (6")
- VJ 10 FT. WHITE SKIP (6")

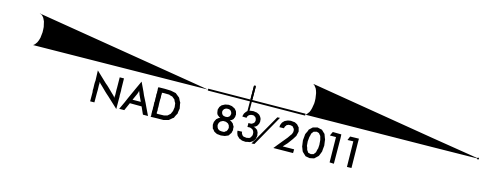
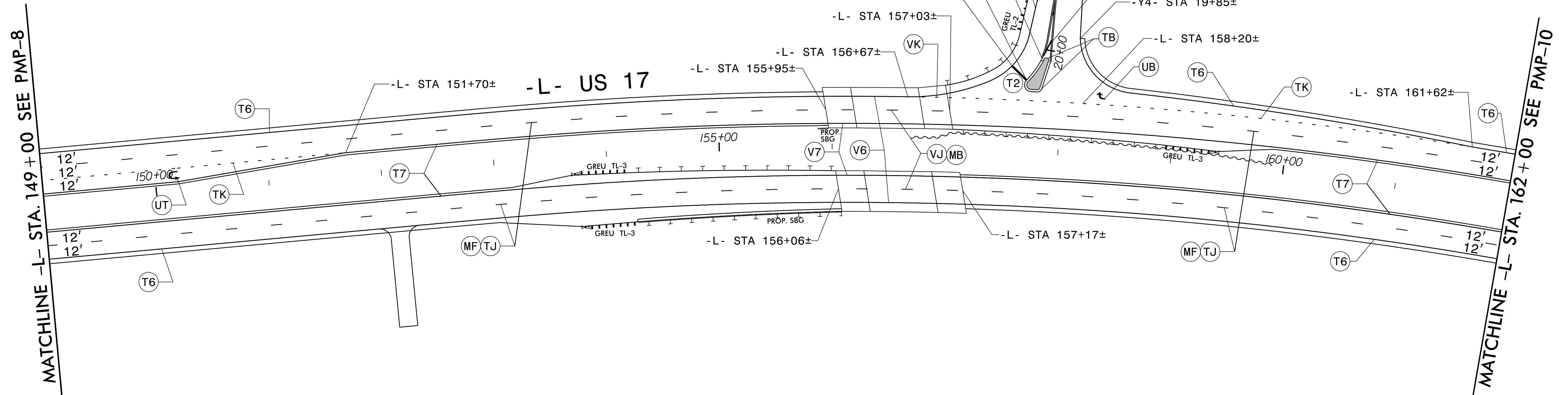

10/1/2021 10:51:00 AM I:\Projects\2021\2511_PMP\PSH09.dgn

RKK
 P: (919) 578-9500
 8601 Six Forks Road Forum 1 Suite 700 | Raleigh, North Carolina 27615
 NC License No. F-0112
 Engineers | Construction Managers | Planners | Scientists
 www.rkk.com
 Responsive People | Creative Solutions

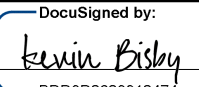
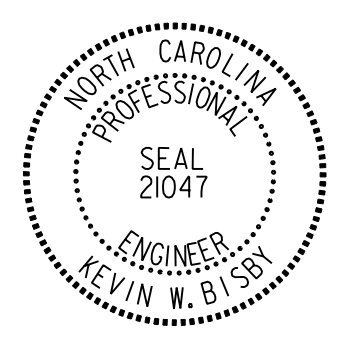
TIP NO. R-2511	SHEET NO. PMP-10
APPROVED:  DATE: 10/1/2021	
SEAL 	
DOCUMENT NOT CONSIDERED FINAL UNLESS ALL SIGNATURES COMPLETED	

PAVEMENT MARKING SCHEDULE

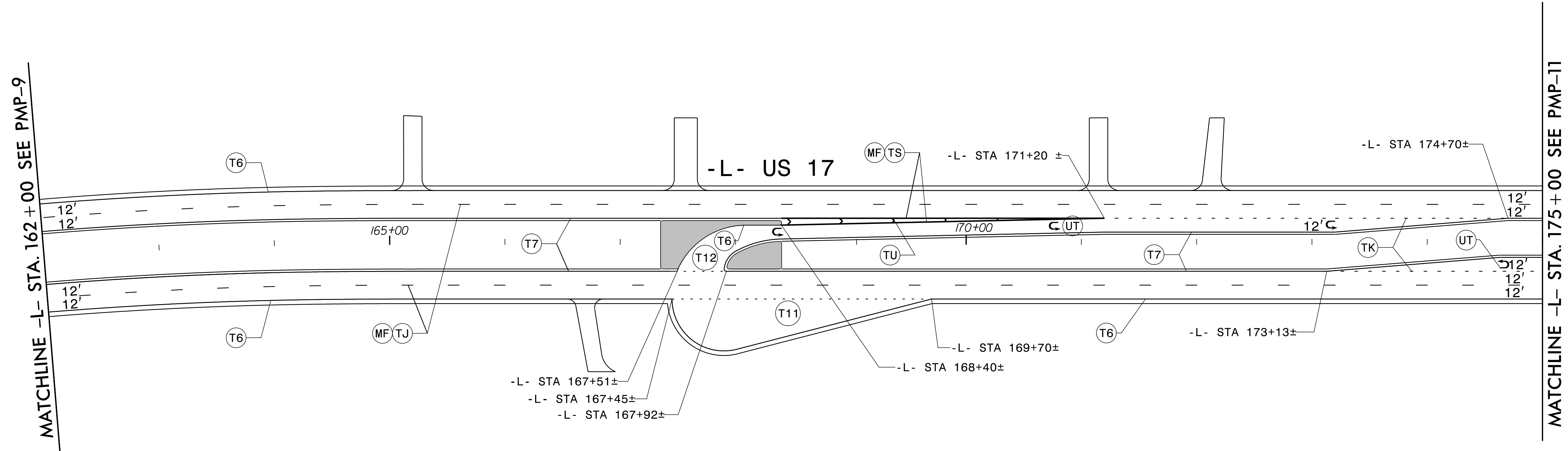
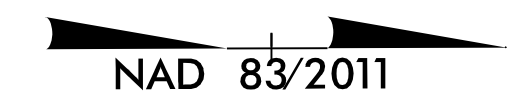

THERMOPLASTIC LINES (90 MILS)	THERMOPLASTIC SYMBOLS (90 MILS)
T2 WHITE STOPBAR (24")	UA LEFT TURN ARROW
T6 WHITE EDGELINE (6")	UB RIGHT TURN ARROW
T7 YELLOW EDGELINE (6")	UN 24" YIELD LINE TRIANGLE
T11 2 FT. -6 FT./SP WHITE MINISKIP (6")	UT U-TURN ARROW
T12 2 FT. -6 FT./SP YELLOW MINISKIP (6")	
TA WHITE EDGELINE (4")	
TB YELLOW EDGELINE (4")	PAVEMENT MARKERS
TI YELLOW DOUBLE CENTERLINE (4")	MA PERMANENT RAISED (YELLOW & YELLOW)
TJ 10 FT. WHITE SKIP (6")	MB PERMANENT RAISED (CRYSTAL & RED)
TK 3 FT.-9 FT./SP WHITE MINISKIP (6")	ME SNOWPLOWABLE (YELLOW & YELLOW)
TP YELLOW DIAGONAL (8")	MF SNOWPLOWABLE (CRYSTAL & RED)
TU WHITE DIAGONAL (12")	
TS WHITE GORELINE (12")	
POLYUREA LINES	
VK 3 FT.-9 FT./SP WHITE MINISKIP (6")	
V6 WHITE EDGELINE (6")	
V7 YELLOW EDGELINE (6")	
VJ 10 FT. WHITE SKIP (6")	



I:\2021\2021_PMP_PSH10.dgn

RKK
 P: (919) 578-9500
 8601 Six Forks Road Forum 1 Suite 700 | Raleigh, North Carolina 27615
 NC License No. F-0112
 Engineers | Construction Managers | Planners | Scientists
 www.rkk.com
 Responsive People | Creative Solutions

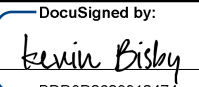
PAVEMENT MARKING DETAIL

TIP NO. R-2511	SHEET NO. PMP-11
APPROVED:  DATE: 10/1/2021	
SEAL 	
DOCUMENT NOT CONSIDERED FINAL UNLESS ALL SIGNATURES COMPLETED	

PAVEMENT MARKING SCHEDULE

THERMOPLASTIC LINES (90 MILS)	THERMOPLASTIC SYMBOLS (90 MILS)
T2 WHITE STOPBAR (24")	UA LEFT TURN ARROW
T6 WHITE EDGELINE (6")	UB RIGHT TURN ARROW
T7 YELLOW EDGELINE (6")	UN 24" YIELD LINE TRIANGLE
T11 2 FT. -6 FT./SP WHITE MINISKIP (6")	UT U-TURN ARROW
T12 2 FT. -6 FT./SP YELLOW MINISKIP (6")	
TA WHITE EDGELINE (4")	
TB YELLOW EDGELINE (4")	PAVEMENT MARKERS
TI YELLOW DOUBLE CENTERLINE (4")	MA PERMANENT RAISED (YELLOW & YELLOW)
TJ 10 FT. WHITE SKIP (6")	MB PERMANENT RAISED (CRYSTAL & RED)
TK 3 FT.-9 FT./SP WHITE MINISKIP (6")	ME SNOWPLOWABLE (YELLOW & YELLOW)
TP YELLOW DIAGONAL (8")	MF SNOWPLOWABLE (CRYSTAL & RED)
TU WHITE DIAGONAL (12")	
TS WHITE GORELINE (12")	
POLYUREA LINES	
VK 3 FT.-9 FT./SP WHITE MINISKIP (6")	
V6 WHITE EDGELINE (6")	
V7 YELLOW EDGELINE (6")	
VJ 10 FT. WHITE SKIP (6")	

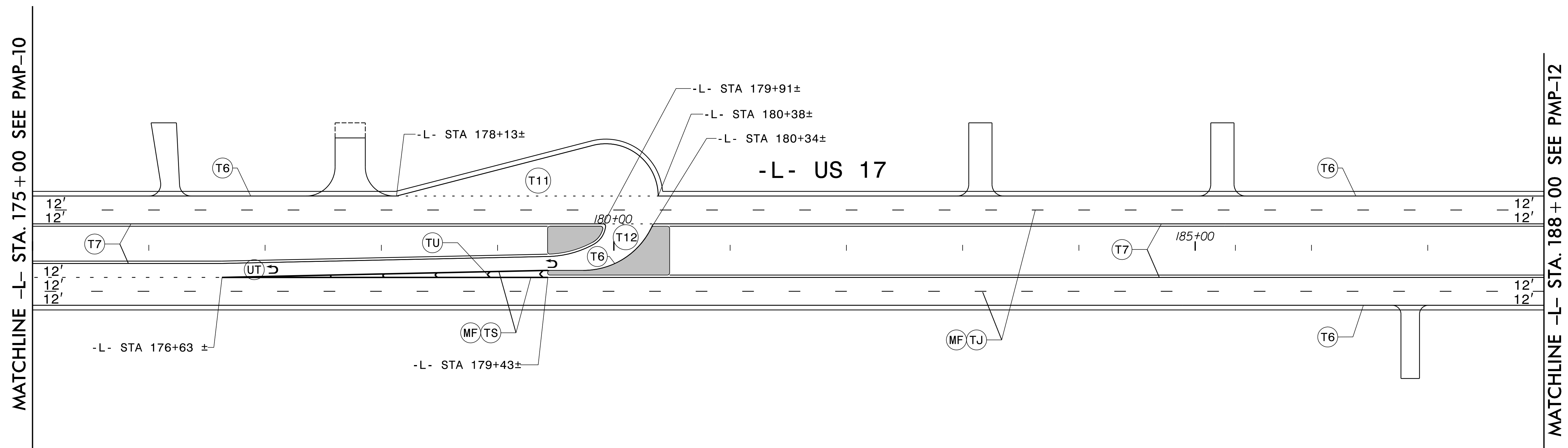
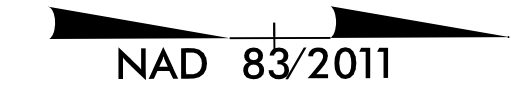

I:\2021\2021_PMP_PSH11.dgn

RKK
 P: (919) 578-9500
 8601 Six Forks Road Forum 1 Suite 700 | Raleigh, North Carolina 27615
 NC License No. F-0112
 Engineers | Construction Managers | Planners | Scientists
 www.rkk.com
 Responsive People | Creative Solutions

PAVEMENT MARKING DETAIL

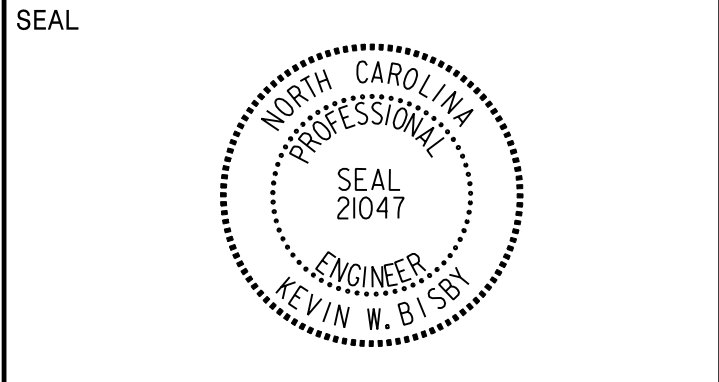

**DOCUMENT NOT CONSIDERED FINAL
UNLESS ALL SIGNATURES COMPLETED**

PAVEMENT MARKING SCHEDULE

<u>THERMOPLASTIC LINES (90 MILS)</u>		<u>THERMOPLASTIC SYMBOLS (90 MILS)</u>	
T2	WHITE STOPBAR (24")	UA	LEFT TURN ARROW
T6	WHITE EDGELINE (6")	UB	RIGHT TURN ARROW
T7	YELLOW EDGELINE (6")	UN	24" YIELD LINE TRIANGLE
T11	2 FT. -6 FT./SP WHITE MINISKIP (6")	UT	U-TURN ARROW
T12	2 FT. -6 FT./SP YELLOW MINISKIP (6")		
TA	WHITE EDGELINE (4")	<u>PAVEMENT MARKERS</u>	
TB	YELLOW EDGELINE (4")	MA	PERMANENT RAISED (YELLOW & YELLOW)
TI	YELLOW DOUBLE CENTERLINE (4")	MB	PERMANENT RAISED (CRYSTAL & RED)
TJ	10 FT. WHITE SKIP (6")	ME	SNOWPLOWABLE (YELLOW & YELLOW)
TK	3 FT.-9 FT./SP WHITE MINISKIP (6")	MF	SNOWPLOWABLE (CRYSTAL & RED)
TP	YELLOW DIAGONAL (8")		
TU	WHITE DIAGONAL (12")		
TS	WHITE GORELINE (12")		
<u>POLYUREA LINES</u>			
VK	3 FT.-9 FT./SP WHITE MINISKIP (6")		
V6	WHITE EDGELINE (6")		
V7	YELLOW EDGELINE (6")		
VJ	10 FT. WHITE SKIP (6")		

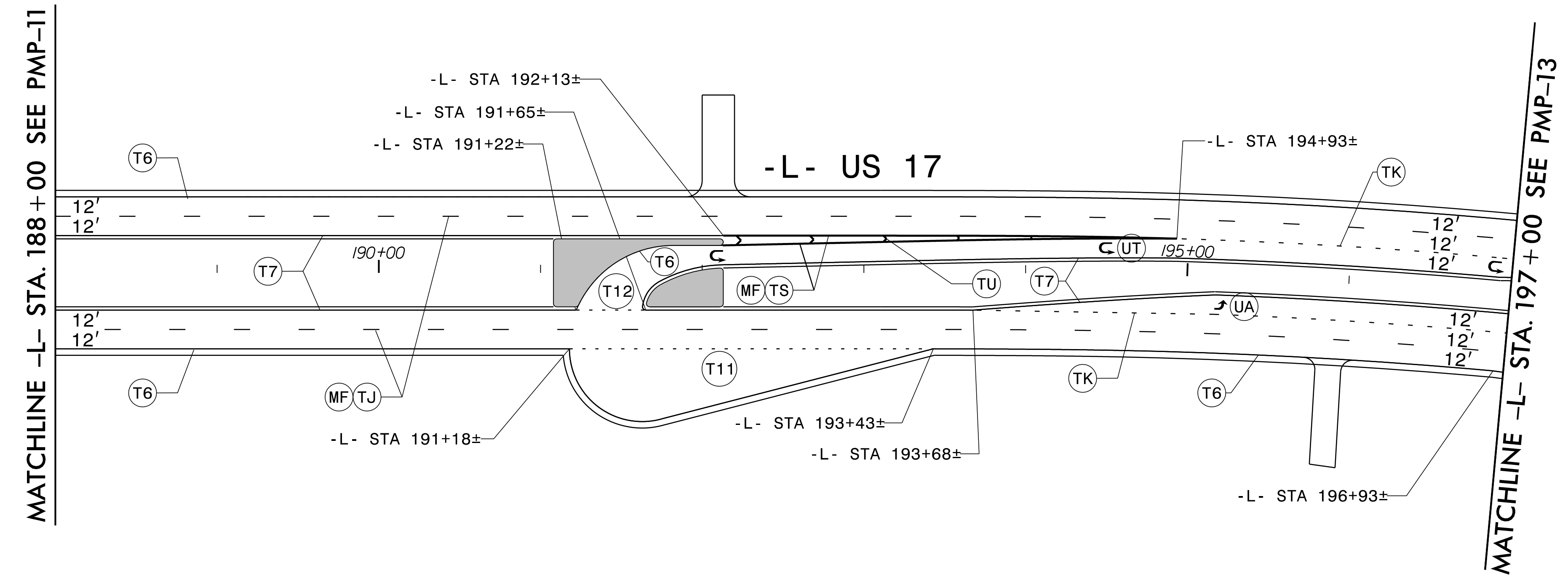
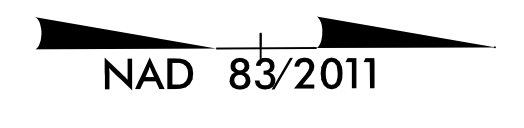

I:\A\2021\10\1\2021_PMP_PSH12.dgn
 Kevin B. Biss

SEAL

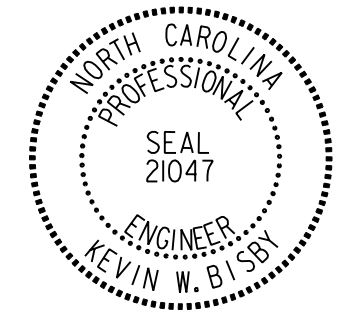

DOCUMENT NOT CONSIDERED FINAL
 UNLESS ALL SIGNATURES COMPLETED

PAVEMENT MARKING SCHEDULE

THERMOPLASTIC LINES (90 MILS)

- T2 WHITE STOPBAR (24")
- T6 WHITE EDGELINE (6")
- T7 YELLOW EDGELINE (6")
- T11 2 FT. -6 FT./SP WHITE MINISKIP (6")
- T12 2 FT. -6 FT./SP YELLOW MINISKIP (6")
- TA WHITE EDGELINE (4")
- TB YELLOW EDGELINE (4")
- TI YELLOW DOUBLE CENTERLINE (4")
- TJ 10 FT. WHITE SKIP (6")
- TK 3 FT.-9 FT./SP WHITE MINISKIP (6")
- TP YELLOW DIAGONAL (8")
- TU WHITE DIAGONAL (12")
- TS WHITE GORELINE (12")

THERMOPLASTIC SYMBOLS (90 MILS)

- UA LEFT TURN ARROW
- UB RIGHT TURN ARROW
- UN 24" YIELD LINE TRIANGLE
- UT U-TURN ARROW

PAVEMENT MARKERS

- MA PERMANENT RAISED (YELLOW & YELLOW)
- MB PERMANENT RAISED (CRYSTAL & RED)
- ME SNOWPLOWABLE (YELLOW & YELLOW)
- MF SNOWPLOWABLE (CRYSTAL & RED)

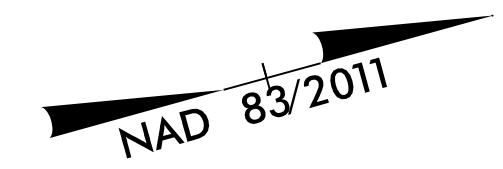
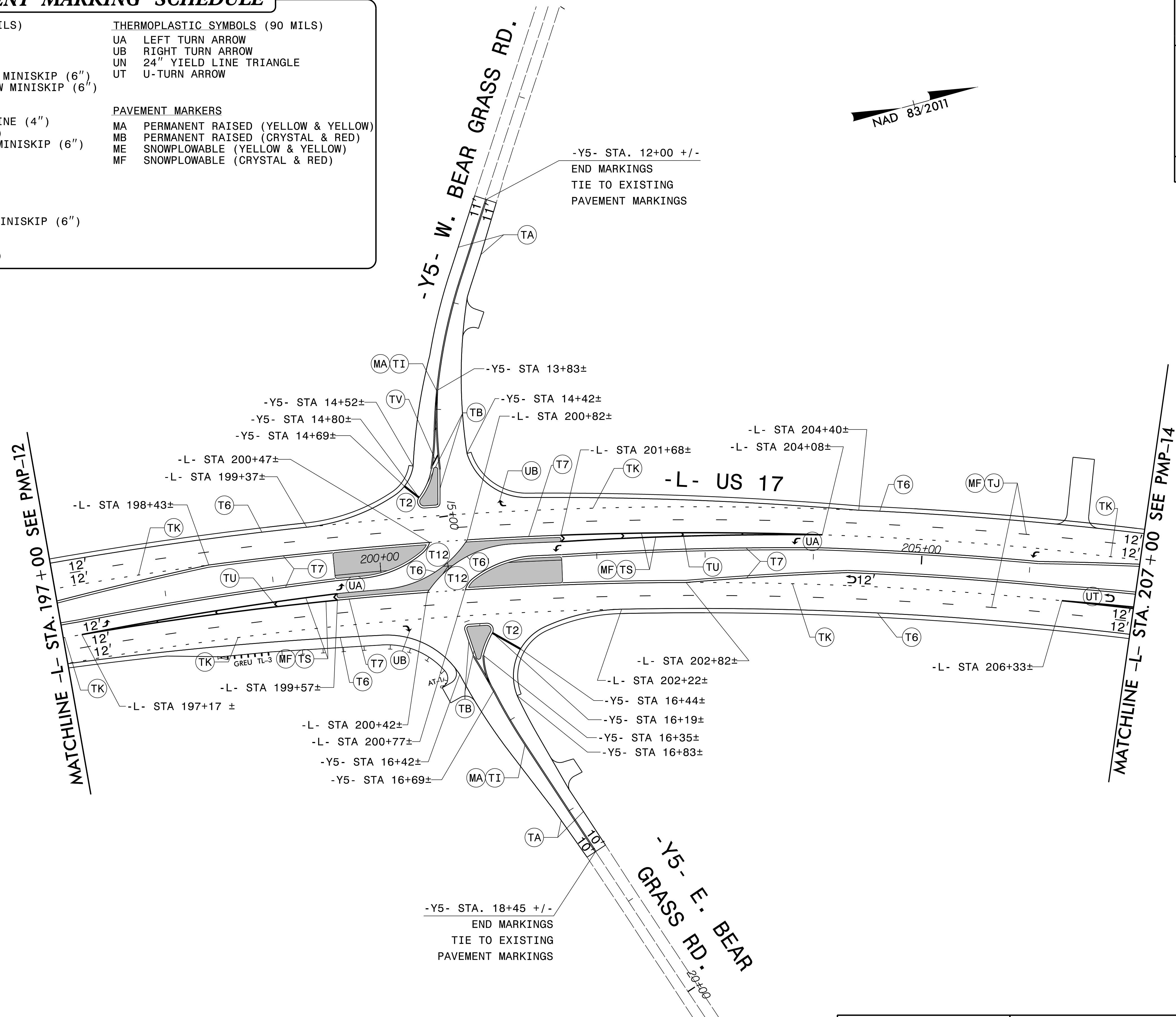

POLYUREA LINES

- VK 3 FT.-9 FT./SP WHITE MINISKIP (6")
- V6 WHITE EDGELINE (6")
- V7 YELLOW EDGELINE (6")
- VJ 10 FT. WHITE SKIP (6")

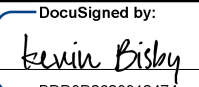

10/1/2021 1:45 PM PMP_PSHI3.dgn

RKK
 P: (919) 578-9500
 8601 Six Forks Road Forum 1 Suite 700 | Raleigh, North Carolina 27615
 NC License No. F-0112
 Engineers | Construction Managers | Planners | Scientists
 www.rkk.com
 Responsive People | Creative Solutions

TIP NO. R-2511	SHEET NO. PMP-14
APPROVED:  DATE: 10/1/2021	
SEAL 	
DOCUMENT NOT CONSIDERED FINAL UNLESS ALL SIGNATURES COMPLETED	

PAVEMENT MARKING SCHEDULE

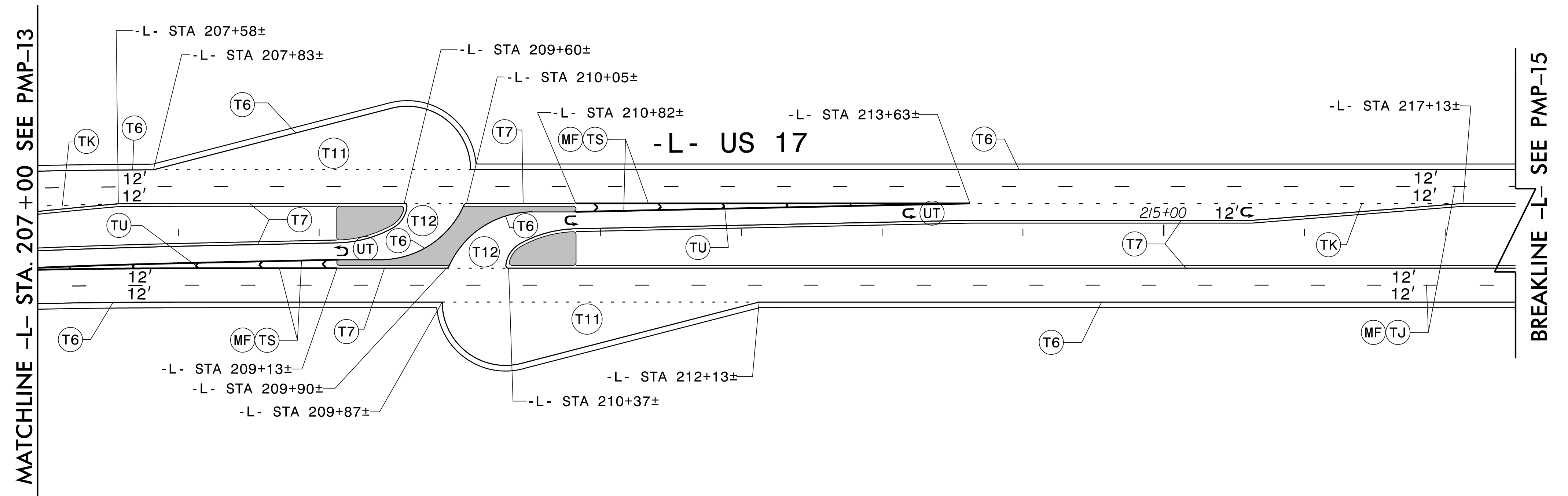
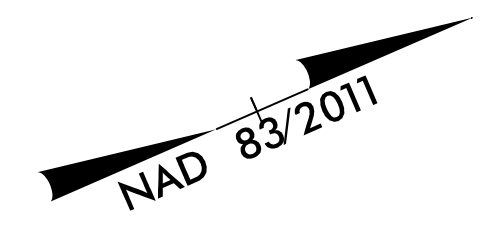

THERMOPLASTIC LINES (90 MILS)	THERMOPLASTIC SYMBOLS (90 MILS)
T2 WHITE STOPBAR (24")	UA LEFT TURN ARROW
T6 WHITE EDGELINE (6")	UB RIGHT TURN ARROW
T7 YELLOW EDGELINE (6")	UN 24" YIELD LINE TRIANGLE
T11 2 FT. -6 FT./SP WHITE MINISKIP (6")	UT U-TURN ARROW
T12 2 FT. -6 FT./SP YELLOW MINISKIP (6")	
TA WHITE EDGELINE (4")	
TB YELLOW EDGELINE (4")	PAVEMENT MARKERS
TI YELLOW DOUBLE CENTERLINE (4")	MA PERMANENT RAISED (YELLOW & YELLOW)
TJ 10 FT. WHITE SKIP (6")	MB PERMANENT RAISED (CRYSTAL & RED)
TK 3 FT.-9 FT./SP WHITE MINISKIP (6")	ME SNOWPLOWABLE (YELLOW & YELLOW)
TP YELLOW DIAGONAL (8")	MF SNOWPLOWABLE (CRYSTAL & RED)
TU WHITE DIAGONAL (12")	
TS WHITE GORELINE (12")	
POLYUREA LINES	
VK 3 FT.-9 FT./SP WHITE MINISKIP (6")	
V6 WHITE EDGELINE (6")	
V7 YELLOW EDGELINE (6")	
VJ 10 FT. WHITE SKIP (6")	



10/1/2021
C:\PMP_PSH14.dgn
K.Bly

RKK
P: (919) 578-9500
8601 Six Forks Road Forum 1 Suite 700 | Raleigh, North Carolina 27615
NC License No. F-0112
Engineers | Construction Managers | Planners | Scientists
www.rkk.com
Responsive People | Creative Solutions

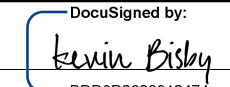
PAVEMENT MARKING DETAIL

TIP NO. R-2511	SHEET NO. PMP-15
APPROVED:  DATE: 10/1/2021	
SEAL 	
DOCUMENT NOT CONSIDERED FINAL UNLESS ALL SIGNATURES COMPLETED	

PAVEMENT MARKING SCHEDULE

THERMOPLASTIC LINES (90 MILS)	THERMOPLASTIC SYMBOLS (90 MILS)
T2 WHITE STOPBAR (24")	UA LEFT TURN ARROW
T6 WHITE EDGELINE (6")	UB RIGHT TURN ARROW
T7 YELLOW EDGELINE (6")	UN 24" YIELD LINE TRIANGLE
T11 2 FT. -6 FT./SP WHITE MINISKIP (6")	UT U-TURN ARROW
T12 2 FT. -6 FT./SP YELLOW MINISKIP (6")	
TA WHITE EDGELINE (4")	
TB YELLOW EDGELINE (4")	PAVEMENT MARKERS
TI YELLOW DOUBLE CENTERLINE (4")	MA PERMANENT RAISED (YELLOW & YELLOW)
TJ 10 FT. WHITE SKIP (6")	MB PERMANENT RAISED (CRYSTAL & RED)
TK 3 FT.-9 FT./SP WHITE MINISKIP (6")	ME SNOWPLOWABLE (YELLOW & YELLOW)
TP YELLOW DIAGONAL (8")	MF SNOWPLOWABLE (CRYSTAL & RED)
TU WHITE DIAGONAL (12")	
TS WHITE GORELINE (12")	
POLYUREA LINES	
VK 3 FT.-9 FT./SP WHITE MINISKIP (6")	
V6 WHITE EDGELINE (6")	
V7 YELLOW EDGELINE (6")	
VJ 10 FT. WHITE SKIP (6")	

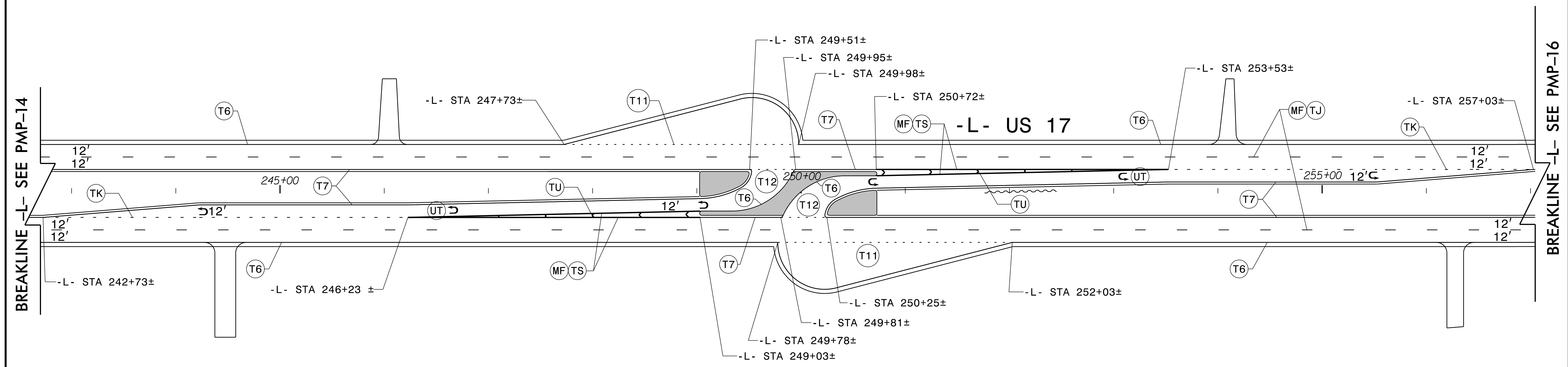
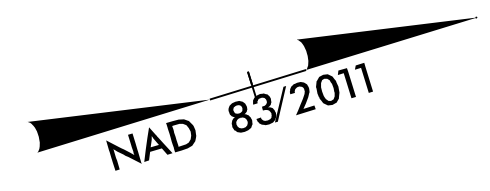

I:\2021\2021_PMP_PSH15.dgn

RKK
 P: (919) 578-9500
 8601 Six Forks Road Forum 1 Suite 700 | Raleigh, North Carolina 27615
 NC License No. F-0112
 Engineers | Construction Managers | Planners | Scientists
 www.rkk.com
 Responsive People | Creative Solutions

PAVEMENT MARKING DETAIL

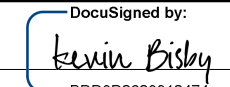
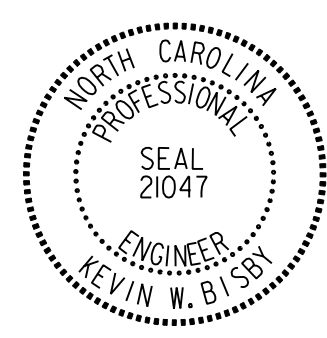
TIP NO. R-2511	SHEET NO. PMP-16
APPROVED:  DATE: 10/1/2021	
SEAL 	
DOCUMENT NOT CONSIDERED FINAL UNLESS ALL SIGNATURES COMPLETED	

PAVEMENT MARKING SCHEDULE

THERMOPLASTIC LINES (90 MILS)	THERMOPLASTIC SYMBOLS (90 MILS)
T2 WHITE STOPBAR (24")	UA LEFT TURN ARROW
T6 WHITE EDGELINE (6")	UB RIGHT TURN ARROW
T7 YELLOW EDGELINE (6")	UN 24" YIELD LINE TRIANGLE
T11 2 FT. -6 FT./SP WHITE MINISKIP (6")	UT U-TURN ARROW
T12 2 FT. -6 FT./SP YELLOW MINISKIP (6")	
TA WHITE EDGELINE (4")	
TB YELLOW EDGELINE (4")	PAVEMENT MARKERS
TI YELLOW DOUBLE CENTERLINE (4")	MA PERMANENT RAISED (YELLOW & YELLOW)
TJ 10 FT. WHITE SKIP (6")	MB PERMANENT RAISED (CRYSTAL & RED)
TK 3 FT. -9 FT./SP WHITE MINISKIP (6")	ME SNOWPLOWABLE (YELLOW & YELLOW)
TP YELLOW DIAGONAL (8")	MF SNOWPLOWABLE (CRYSTAL & RED)
TU WHITE DIAGONAL (12")	
TS WHITE GORELINE (12")	
POLYUREA LINES	
VK 3 FT. -9 FT./SP WHITE MINISKIP (6")	
V6 WHITE EDGELINE (6")	
V7 YELLOW EDGELINE (6")	
VJ 10 FT. WHITE SKIP (6")	

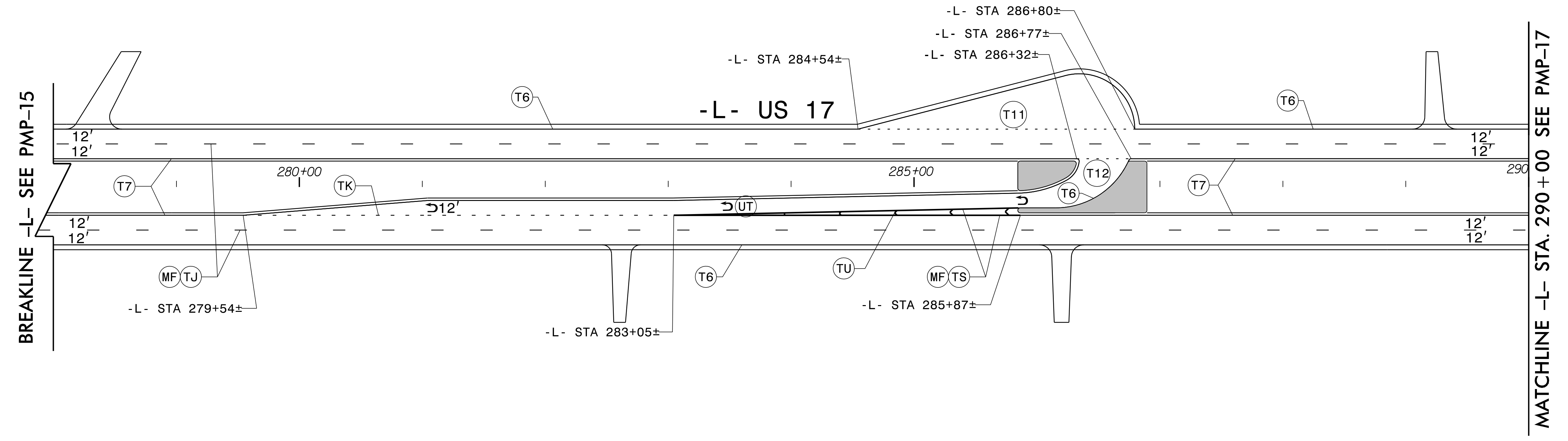
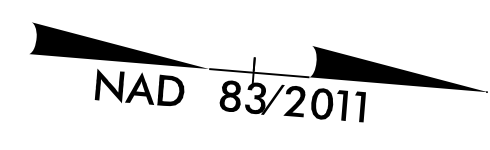

10/1/2021
PMP-16_PSH16.dgn
K.Bly

RKK
P: (919) 578-9500
8601 Six Forks Road Forum 1 Suite 700 | Raleigh, North Carolina 27615
NC License No. F-0112
Engineers | Construction Managers | Planners | Scientists
www.rkk.com
Responsive People | Creative Solutions

PAVEMENT MARKING DETAIL

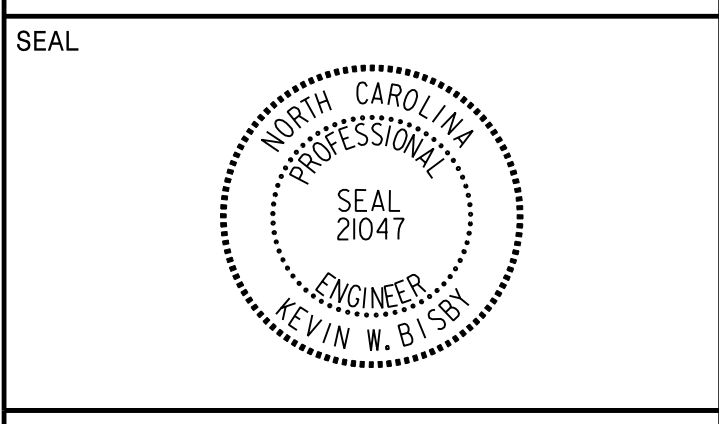

**DOCUMENT NOT CONSIDERED FINAL
UNLESS ALL SIGNATURES COMPLETED**

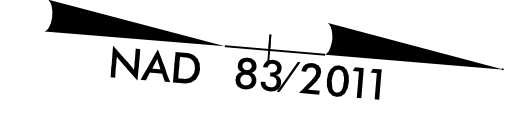

PAVEMENT MARKING SCHEDULE

THERMOPLASTIC LINES (90 MILS)		THERMOPLASTIC SYMBOLS (90 MILS)	
T2	WHITE STOPBAR (24")	UA	LEFT TURN ARROW
T6	WHITE EDGELINE (6")	UB	RIGHT TURN ARROW
T7	YELLOW EDGELINE (6")	UN	24" YIELD LINE TRIANGLE
T11	2 FT. -6 FT./SP WHITE MINISKIP (6")	UT	U-TURN ARROW
T12	2 FT. -6 FT./SP YELLOW MINISKIP (6")		
TA	WHITE EDGELINE (4")	PAVEMENT MARKERS	
TB	YELLOW EDGELINE (4")	MA	PERMANENT RAISED (YELLOW & YELLOW)
TI	YELLOW DOUBLE CENTERLINE (4")	MB	PERMANENT RAISED (CRYSTAL & RED)
TJ	10 FT. WHITE SKIP (6")	ME	SNOWPLOWABLE (YELLOW & YELLOW)
TK	3 FT.-9 FT./SP WHITE MINISKIP (6")	MF	SNOWPLOWABLE (CRYSTAL & RED)
TP	YELLOW DIAGONAL (8")		
TU	WHITE DIAGONAL (12")		
TS	WHITE GORELINE (12")		
POLYUREA LINES			
VK	3 FT.-9 FT./SP WHITE MINISKIP (6")		
V6	WHITE EDGELINE (6")		
V7	YELLOW EDGELINE (6")		
VJ	10 FT. WHITE SKIP (6")		

MATCHLINE -L- STA. 290+00 SEE PMP-16

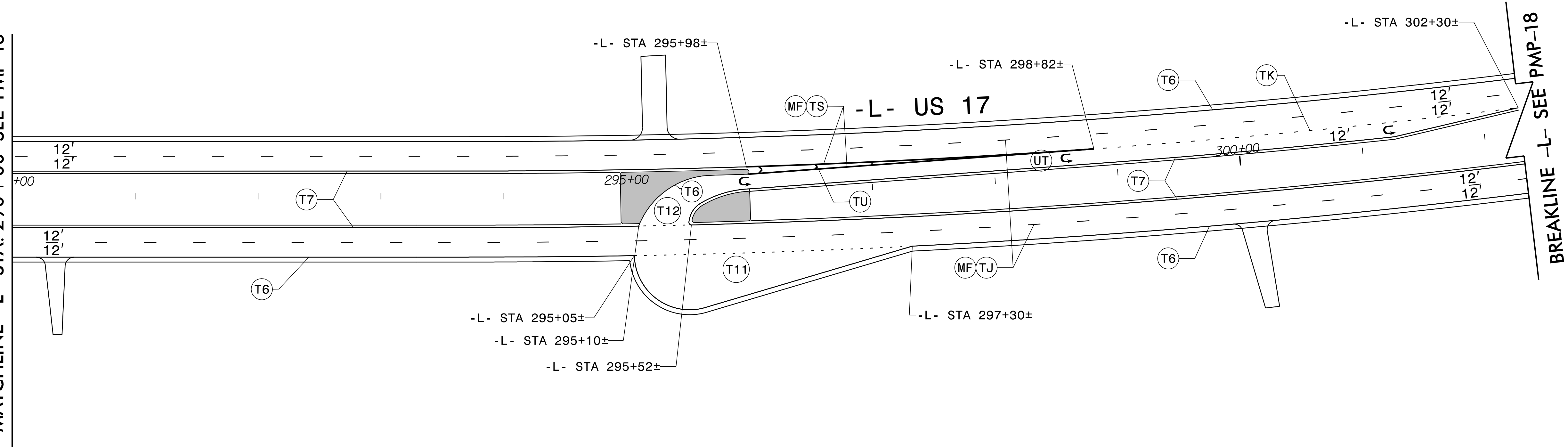

10/1/2021
PMP-17_PSH17.dgn
k.eshy

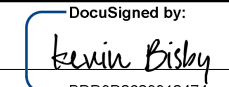
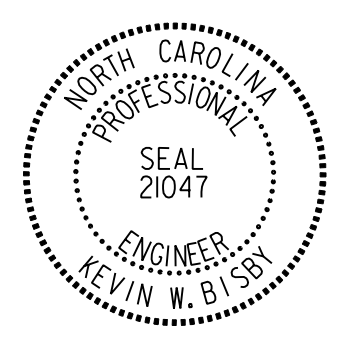
TIP NO. R-2511	SHEET NO. PMP-18
APPROVED:  DATE: 10/1/2021	
SEAL 	
DOCUMENT NOT CONSIDERED FINAL UNLESS ALL SIGNATURES COMPLETED	

PAVEMENT MARKING SCHEDULE

- | | |
|--|--|
| THERMOPLASTIC LINES (90 MILS) | THERMOPLASTIC SYMBOLS (90 MILS) |
| T2 WHITE STOPBAR (24") | UA LEFT TURN ARROW |
| T6 WHITE EDGELINE (6") | UB RIGHT TURN ARROW |
| T7 YELLOW EDGELINE (6") | UN 24" YIELD LINE TRIANGLE |
| T11 2 FT. -6 FT./SP WHITE MINISKIP (6") | UT U-TURN ARROW |
| T12 2 FT. -6 FT./SP YELLOW MINISKIP (6") | |
| TA WHITE EDGELINE (4") | |
| TB YELLOW EDGELINE (4") | PAVEMENT MARKERS |
| TI YELLOW DOUBLE CENTERLINE (4") | MA PERMANENT RAISED (YELLOW & YELLOW) |
| TJ 10 FT. WHITE SKIP (6") | MB PERMANENT RAISED (CRYSTAL & RED) |
| TK 3 FT.-9 FT./SP WHITE MINISKIP (6") | ME SNOWPLOWABLE (YELLOW & YELLOW) |
| TP YELLOW DIAGONAL (8") | MF SNOWPLOWABLE (CRYSTAL & RED) |
| TU WHITE DIAGONAL (12") | |
| TS WHITE GORELINE (12") | |
| POLYUREA LINES | |
| VK 3 FT.-9 FT./SP WHITE MINISKIP (6") | |
| V6 WHITE EDGELINE (6") | |
| V7 YELLOW EDGELINE (6") | |
| VJ 10 FT. WHITE SKIP (6") | |

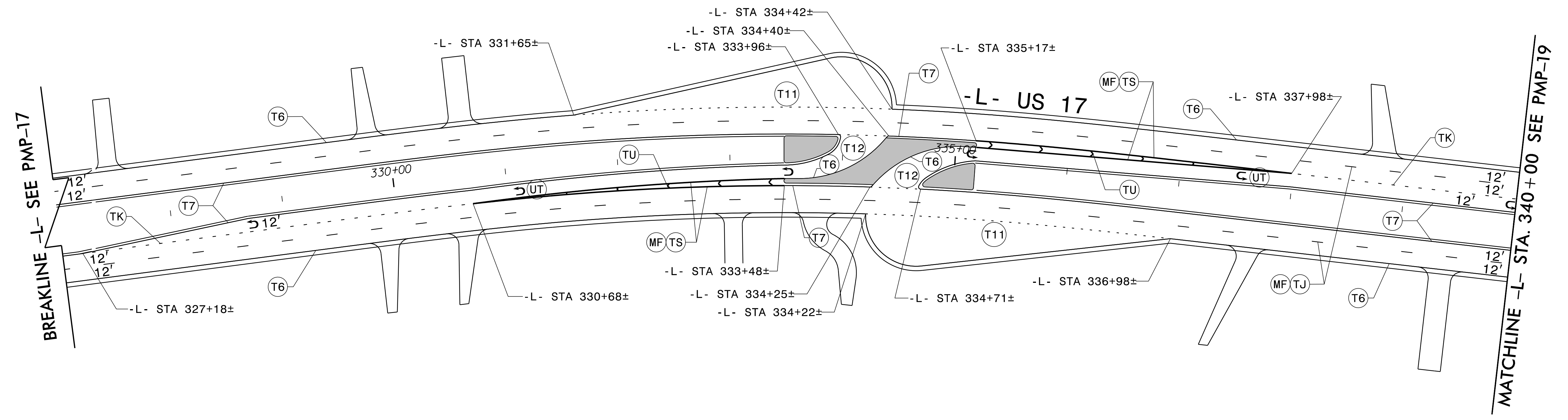
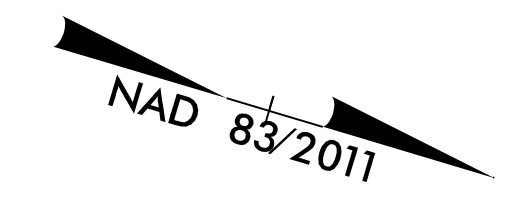

10/1/2021
PMP-18.dgn
PSH18.dgn

RKK
P: (919) 578-9500
8601 Six Forks Road Forum 1 Suite 700 | Raleigh, North Carolina 27615
NC License No. F-0112
www.rkk.com
Responsive People | Creative Solutions

PAVEMENT MARKING DETAIL

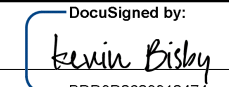
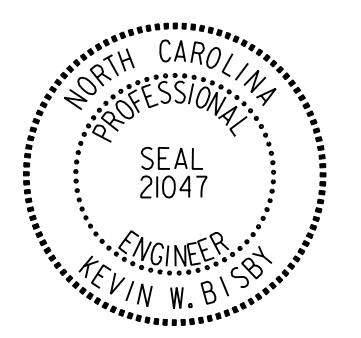
TIP NO. R-2511	SHEET NO. PMP-19
APPROVED:  DATE: 10/1/2021	
SEAL 	
DOCUMENT NOT CONSIDERED FINAL UNLESS ALL SIGNATURES COMPLETED	

PAVEMENT MARKING SCHEDULE

- | | |
|--|--|
| THERMOPLASTIC LINES (90 MILS) | THERMOPLASTIC SYMBOLS (90 MILS) |
| T2 WHITE STOPBAR (24") | UA LEFT TURN ARROW |
| T6 WHITE EDGELINE (6") | UB RIGHT TURN ARROW |
| T7 YELLOW EDGELINE (6") | UN 24" YIELD LINE TRIANGLE |
| T11 2 FT. -6 FT./SP WHITE MINISKIP (6") | UT U-TURN ARROW |
| T12 2 FT. -6 FT./SP YELLOW MINISKIP (6") | |
| TA WHITE EDGELINE (4") | |
| TB YELLOW EDGELINE (4") | PAVEMENT MARKERS |
| TI YELLOW DOUBLE CENTERLINE (4") | MA PERMANENT RAISED (YELLOW & YELLOW) |
| TJ 10 FT. WHITE SKIP (6") | MB PERMANENT RAISED (CRYSTAL & RED) |
| TK 3 FT.-9 FT./SP WHITE MINISKIP (6") | ME SNOWPLOWABLE (YELLOW & YELLOW) |
| TP YELLOW DIAGONAL (8") | MF SNOWPLOWABLE (CRYSTAL & RED) |
| TU WHITE DIAGONAL (12") | |
| TS WHITE GORELINE (12") | |
| POLYUREA LINES | |
| VK 3 FT.-9 FT./SP WHITE MINISKIP (6") | |
| V6 WHITE EDGELINE (6") | |
| V7 YELLOW EDGELINE (6") | |
| VJ 10 FT. WHITE SKIP (6") | |

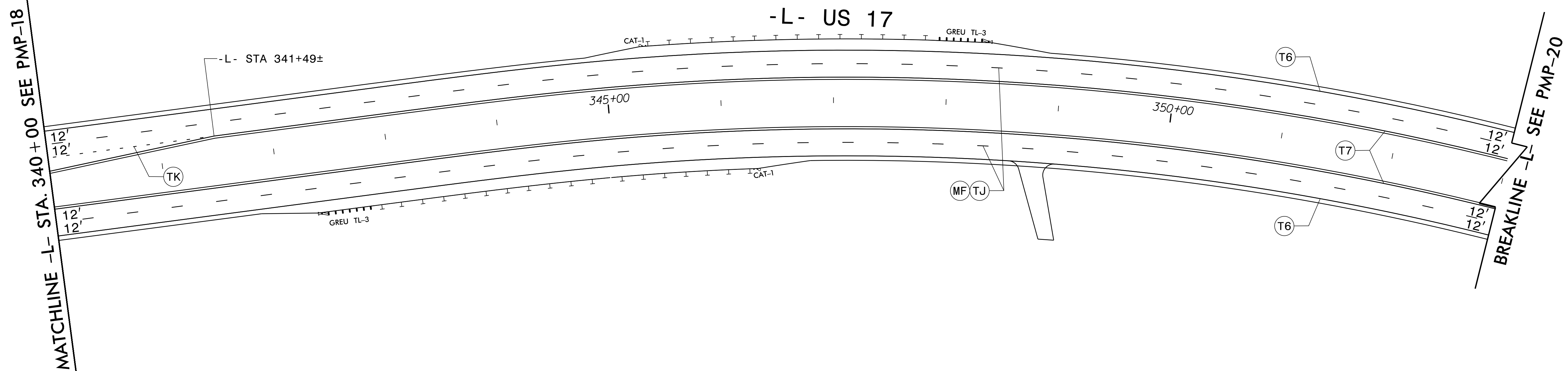
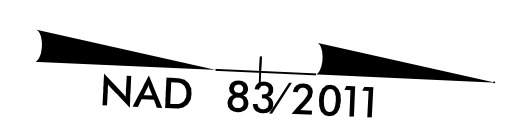

10/1/2021
PMP_PSH19.dgn
kbs

RKK
 P: (919) 578-9500
 8601 Six Forks Road Forum 1 Suite 700 | Raleigh, North Carolina 27615
 NC License No. F-0112
 Engineers | Construction Managers | Planners | Scientists
 www.rkk.com
 Responsive People | Creative Solutions

PAVEMENT MARKING DETAIL

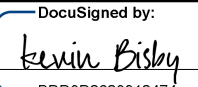
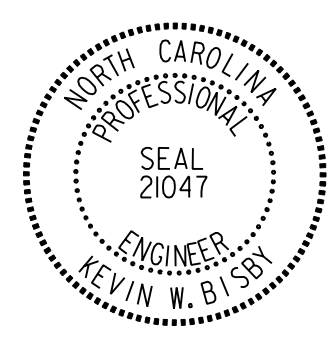
TIP NO. R-2511	SHEET NO. PMP-20
APPROVED:  DATE: 10/1/2021	
SEAL 	
DOCUMENT NOT CONSIDERED FINAL UNLESS ALL SIGNATURES COMPLETED	

PAVEMENT MARKING SCHEDULE

THERMOPLASTIC LINES (90 MILS)

- T2 WHITE STOPBAR (24")
- T6 WHITE EDGELINE (6")
- T7 YELLOW EDGELINE (6")
- T11 2 FT. -6 FT./SP WHITE MINISKIP (6")
- T12 2 FT. -6 FT./SP YELLOW MINISKIP (6")
- TA WHITE EDGELINE (4")
- TB YELLOW EDGELINE (4")
- TI YELLOW DOUBLE CENTERLINE (4")
- TJ 10 FT. WHITE SKIP (6")
- TK 3 FT.-9 FT./SP WHITE MINISKIP (6")
- TP YELLOW DIAGONAL (8")
- TU WHITE DIAGONAL (12")
- TS WHITE GORELINE (12")

THERMOPLASTIC SYMBOLS (90 MILS)

- UA LEFT TURN ARROW
- UB RIGHT TURN ARROW
- UN 24" YIELD LINE TRIANGLE
- UT U-TURN ARROW

PAVEMENT MARKERS

- MA PERMANENT RAISED (YELLOW & YELLOW)
- MB PERMANENT RAISED (CRYSTAL & RED)
- ME SNOWPLOWABLE (YELLOW & YELLOW)
- MF SNOWPLOWABLE (CRYSTAL & RED)

POLYUREA LINES

- VK 3 FT.-9 FT./SP WHITE MINISKIP (6")
- V6 WHITE EDGELINE (6")
- V7 YELLOW EDGELINE (6")
- VJ 10 FT. WHITE SKIP (6")

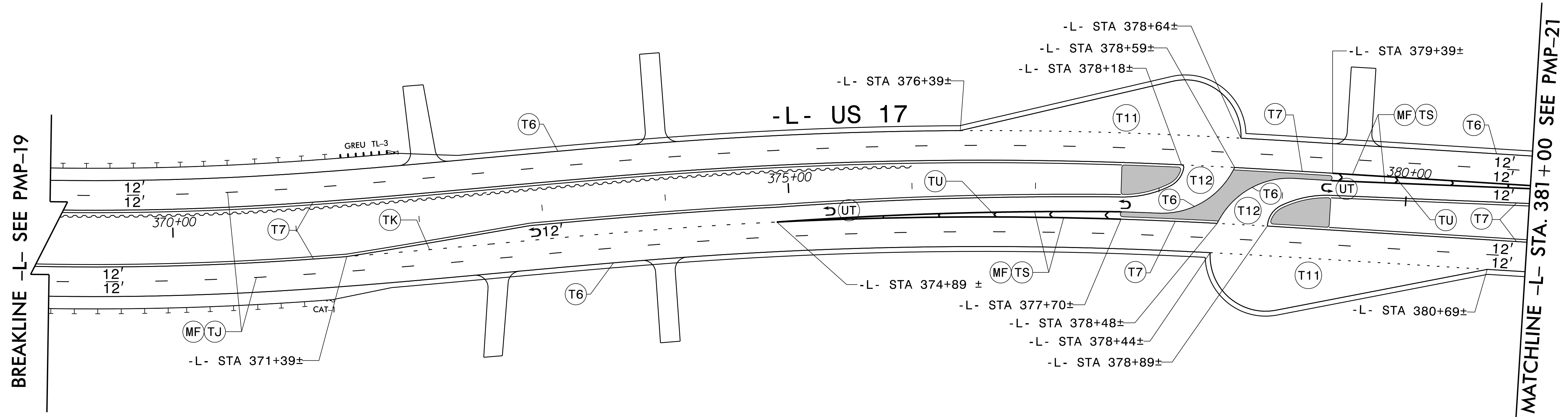
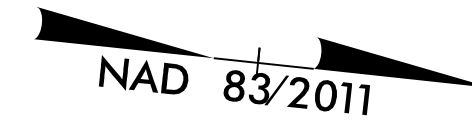

I:\2021\2511\2511_PMP_PSH20.dgn
 Kevin E. Bly
 10/1/2021

RKK
 P: (919) 578-9500
 8601 Six Forks Road Forum 1 Suite 700 | Raleigh, North Carolina 27615
 NC License No. F-0112
 Engineers | Construction Managers | Planners | Scientists
 www.rkk.com
 Responsive People | Creative Solutions

PAVEMENT MARKING DETAIL

PAVEMENT MARKING SCHEDULE

THERMOPLASTIC LINES (90 MILS)	THERMOPLASTIC SYMBOLS (90 MILS)
T2 WHITE STOPBAR (24")	UA LEFT TURN ARROW
T6 WHITE EDGELINE (6")	UB RIGHT TURN ARROW
T7 YELLOW EDGELINE (6")	UN 24" YIELD LINE TRIANGLE
T11 2 FT. -6 FT./SP WHITE MINISKIP (6")	UT U-TURN ARROW
T12 2 FT. -6 FT./SP YELLOW MINISKIP (6")	
TA WHITE EDGELINE (4")	
TB YELLOW EDGELINE (4")	
TI YELLOW DOUBLE CENTERLINE (4")	
TJ 10 FT. WHITE SKIP (6")	
TK 3 FT.-9 FT./SP WHITE MINISKIP (6")	
TP YELLOW DIAGONAL (8")	
TU WHITE DIAGONAL (12")	
TS WHITE GORELINE (12")	
	PAVEMENT MARKERS
	MA PERMANENT RAISED (YELLOW & YELLOW)
	MB PERMANENT RAISED (CRYSTAL & RED)
	ME SNOWPLOWABLE (YELLOW & YELLOW)
	MF SNOWPLOWABLE (CRYSTAL & RED)
POLYUREA LINES	
VK 3 FT.-9 FT./SP WHITE MINISKIP (6")	
V6 WHITE EDGELINE (6")	
V7 YELLOW EDGELINE (6")	
VJ 10 FT. WHITE SKIP (6")	

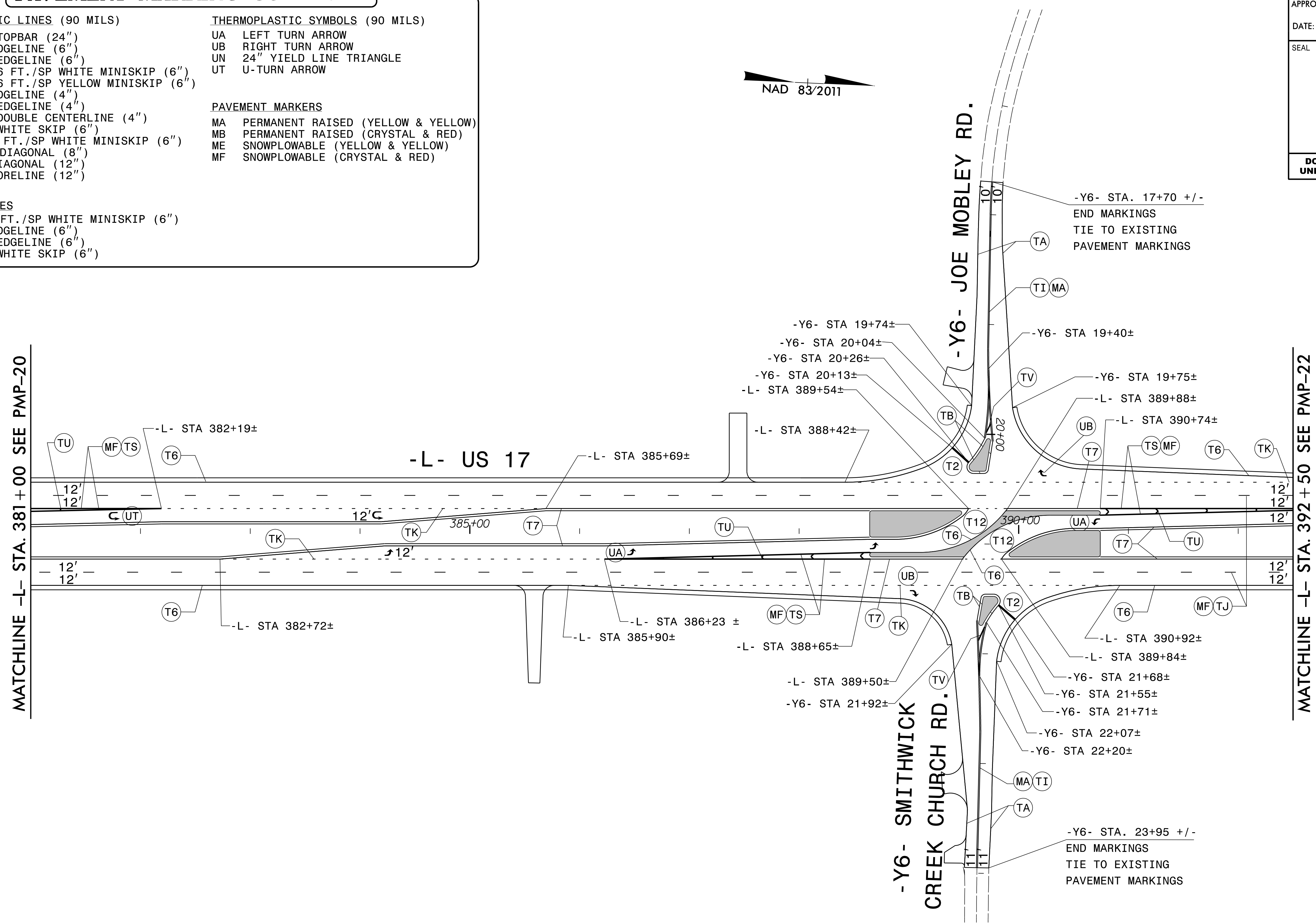
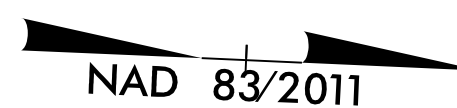

I:\A\2021\2021_PMP_PSH21.dgn
 Kevin E. Eby

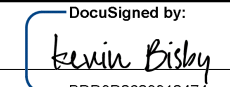
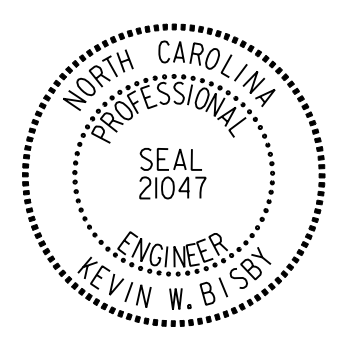
TIP NO. R-2511	SHEET NO. PMP-22
APPROVED:  DATE: 10/1/2021	
SEAL 	
DOCUMENT NOT CONSIDERED FINAL UNLESS ALL SIGNATURES COMPLETED	

PAVEMENT MARKING SCHEDULE

THERMOPLASTIC LINES (90 MILS)	THERMOPLASTIC SYMBOLS (90 MILS)
T2 WHITE STOPBAR (24")	UA LEFT TURN ARROW
T6 WHITE EDGELINE (6")	UB RIGHT TURN ARROW
T7 YELLOW EDGELINE (6")	UN 24" YIELD LINE TRIANGLE
T11 2 FT. -6 FT./SP WHITE MINISKIP (6")	UT U-TURN ARROW
T12 2 FT. -6 FT./SP YELLOW MINISKIP (6")	
TA WHITE EDGELINE (4")	
TB YELLOW EDGELINE (4")	PAVEMENT MARKERS
TI YELLOW DOUBLE CENTERLINE (4")	MA PERMANENT RAISED (YELLOW & YELLOW)
TJ 10 FT. WHITE SKIP (6")	MB PERMANENT RAISED (CRYSTAL & RED)
TK 3 FT.-9 FT./SP WHITE MINISKIP (6")	ME SNOWPLOWABLE (YELLOW & YELLOW)
TP YELLOW DIAGONAL (8")	MF SNOWPLOWABLE (CRYSTAL & RED)
TU WHITE DIAGONAL (12")	
TS WHITE GORELINE (12")	
POLYUREA LINES	
VK 3 FT.-9 FT./SP WHITE MINISKIP (6")	
V6 WHITE EDGELINE (6")	
V7 YELLOW EDGELINE (6")	
VJ 10 FT. WHITE SKIP (6")	

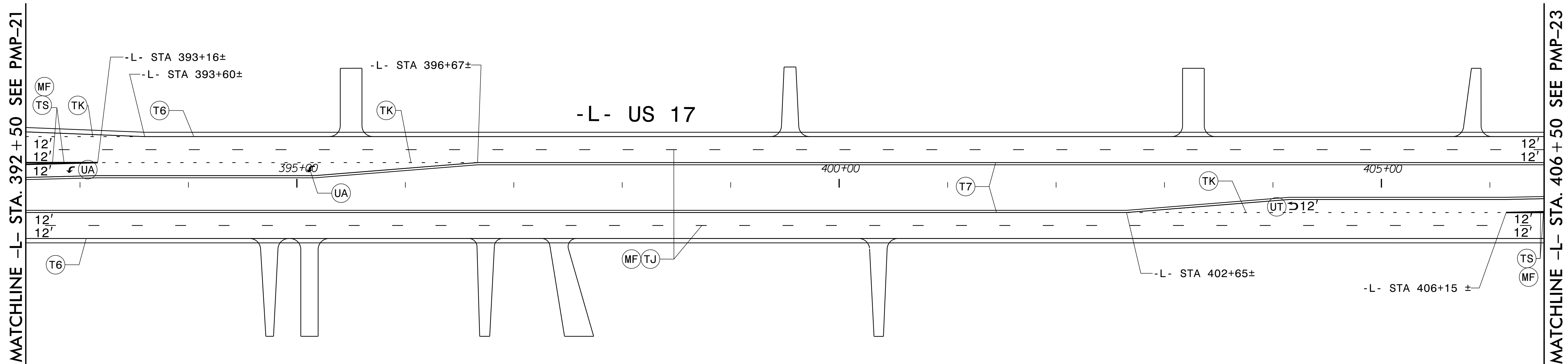
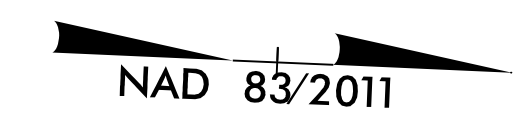

I:\A\2021\10\1\2021_PMP_PSH22.dgn

RKK
 P: (919) 578-9500
 8601 Six Forks Road Forum 1 Suite 700 | Raleigh, North Carolina 27615
 NC License No. F-0112
 Engineers | Construction Managers | Planners | Scientists
 www.rkk.com
 Responsive People | Creative Solutions

PAVEMENT MARKING DETAIL

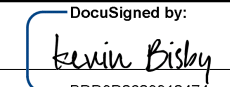
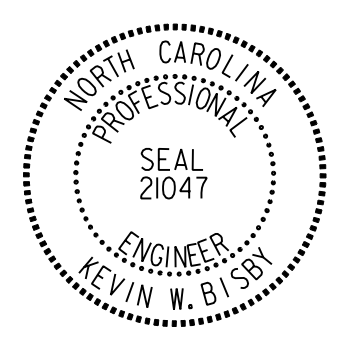
TIP NO. R-2511	SHEET NO. PMP-23
APPROVED:  DATE: 10/1/2021	
SEAL 	
DOCUMENT NOT CONSIDERED FINAL UNLESS ALL SIGNATURES COMPLETED	

PAVEMENT MARKING SCHEDULE

THERMOPLASTIC LINES (90 MILS)	THERMOPLASTIC SYMBOLS (90 MILS)
T2 WHITE STOPBAR (24")	UA LEFT TURN ARROW
T6 WHITE EDGELINE (6")	UB RIGHT TURN ARROW
T7 YELLOW EDGELINE (6")	UN 24" YIELD LINE TRIANGLE
T11 2 FT. -6 FT./SP WHITE MINISKIP (6")	UT U-TURN ARROW
T12 2 FT. -6 FT./SP YELLOW MINISKIP (6")	
TA WHITE EDGELINE (4")	
TB YELLOW EDGELINE (4")	PAVEMENT MARKERS
TI YELLOW DOUBLE CENTERLINE (4")	MA PERMANENT RAISED (YELLOW & YELLOW)
TJ 10 FT. WHITE SKIP (6")	MB PERMANENT RAISED (CRYSTAL & RED)
TK 3 FT.-9 FT./SP WHITE MINISKIP (6")	ME SNOWPLOWABLE (YELLOW & YELLOW)
TP YELLOW DIAGONAL (8")	MF SNOWPLOWABLE (CRYSTAL & RED)
TU WHITE DIAGONAL (12")	
TS WHITE GORELINE (12")	
POLYUREA LINES	
VK 3 FT.-9 FT./SP WHITE MINISKIP (6")	
V6 WHITE EDGELINE (6")	
V7 YELLOW EDGELINE (6")	
VJ 10 FT. WHITE SKIP (6")	

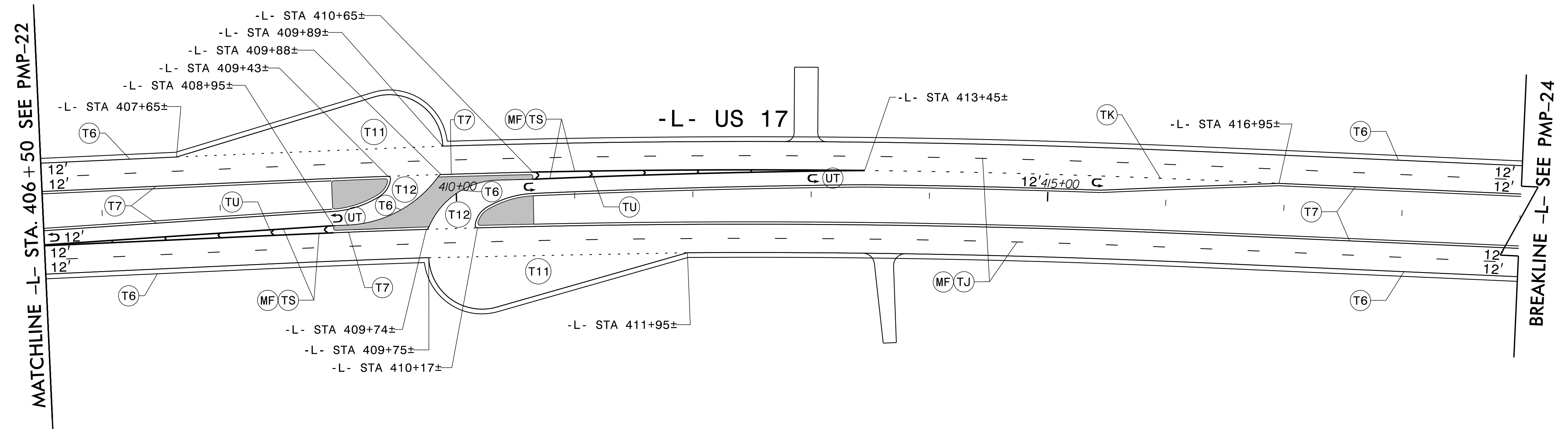
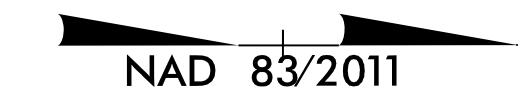

10/1/2021
D:\C\Projects\PMP_PSH23.dgn
K. Bly

RKK
 P: (919) 578-9500
 8601 Six Forks Road Forum 1 Suite 700 | Raleigh, North Carolina 27615
 NC License No. F-0112
 Engineers | Construction Managers | Planners | Scientists
 www.rkk.com
 Responsive People | Creative Solutions

PAVEMENT MARKING DETAIL

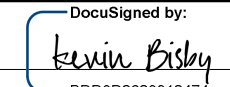
APPROVED: 
 DATE: 10/1/2021

SEAL



DOCUMENT NOT CONSIDERED FINAL UNLESS ALL SIGNATURES COMPLETED

PAVEMENT MARKING SCHEDULE

- THERMOPLASTIC LINES (90 MILS)**
- T2 WHITE STOPBAR (24")
 - T6 WHITE EDGELINE (6")
 - T7 YELLOW EDGELINE (6")
 - T11 2 FT. -6 FT./SP WHITE MINISKIP (6")
 - T12 2 FT. -6 FT./SP YELLOW MINISKIP (6")
 - TA WHITE EDGELINE (4")
 - TB YELLOW EDGELINE (4")
 - TI YELLOW DOUBLE CENTERLINE (4")
 - TJ 10 FT. WHITE SKIP (6")
 - TK 3 FT.-9 FT./SP WHITE MINISKIP (6")
 - TP YELLOW DIAGONAL (8")
 - TU WHITE DIAGONAL (12")
 - TS WHITE GORELINE (12")
- THERMOPLASTIC SYMBOLS (90 MILS)**
- UA LEFT TURN ARROW
 - UB RIGHT TURN ARROW
 - UN 24" YIELD LINE TRIANGLE
 - UT U-TURN ARROW
- PAVEMENT MARKERS**
- MA PERMANENT RAISED (YELLOW & YELLOW)
 - MB PERMANENT RAISED (CRYSTAL & RED)
 - ME SNOWPLOWABLE (YELLOW & YELLOW)
 - MF SNOWPLOWABLE (CRYSTAL & RED)
- POLYUREA LINES**
- VK 3 FT.-9 FT./SP WHITE MINISKIP (6")
 - V6 WHITE EDGELINE (6")
 - V7 YELLOW EDGELINE (6")
 - VJ 10 FT. WHITE SKIP (6")

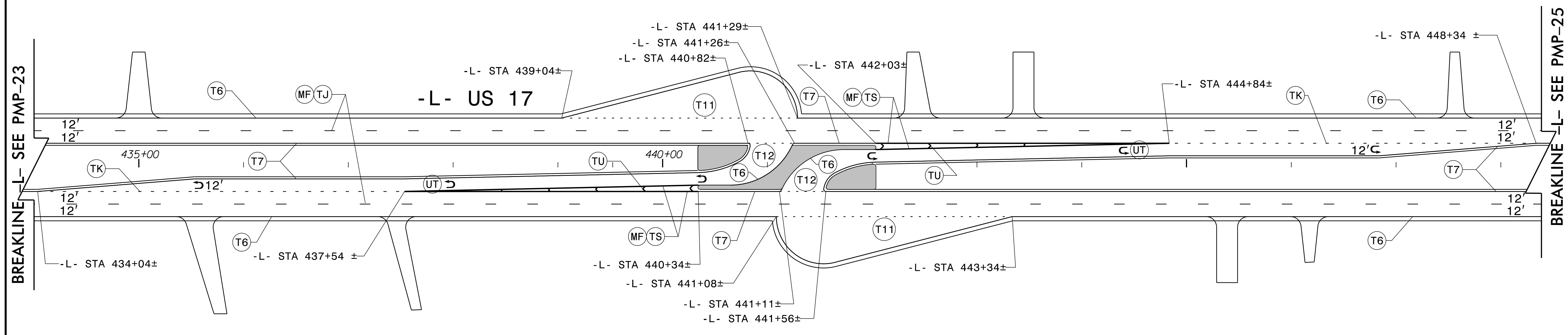
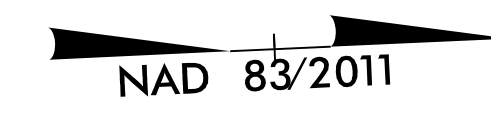

I:\2021\10\1\2021_PMP_PSH24.dgn

RKK
 P: (919) 578-8500
 8601 Six Forks Road Forum 1 Suite 700 | Raleigh, North Carolina 27615
 NC License No. F-0112
 Engineers | Construction Managers | Planners | Scientists
www.rkk.com
 Responsive People | Creative Solutions

PAVEMENT MARKING DETAIL

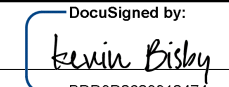
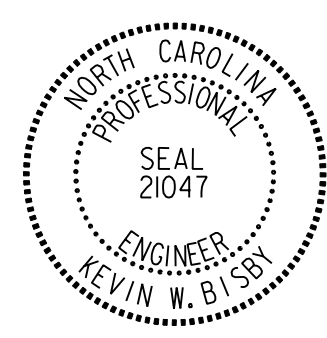
TIP NO. R-2511	SHEET NO. PMP-25
APPROVED:  DATE: 10/1/2021	
SEAL 	
DOCUMENT NOT CONSIDERED FINAL UNLESS ALL SIGNATURES COMPLETED	

PAVEMENT MARKING SCHEDULE

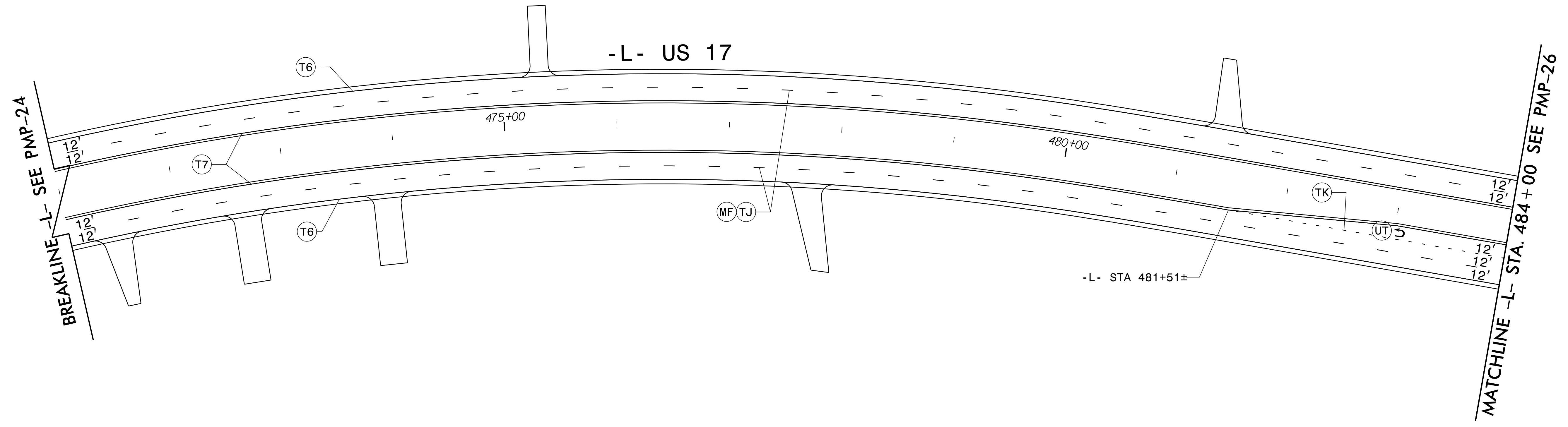
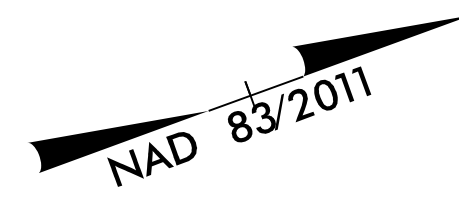

THERMOPLASTIC LINES (90 MILS)	THERMOPLASTIC SYMBOLS (90 MILS)
T2 WHITE STOPBAR (24")	UA LEFT TURN ARROW
T6 WHITE EDGELINE (6")	UB RIGHT TURN ARROW
T7 YELLOW EDGELINE (6")	UN 24" YIELD LINE TRIANGLE
T11 2 FT. -6 FT./SP WHITE MINISKIP (6")	UT U-TURN ARROW
T12 2 FT. -6 FT./SP YELLOW MINISKIP (6")	
TA WHITE EDGELINE (4")	
TB YELLOW EDGELINE (4")	PAVEMENT MARKERS
TI YELLOW DOUBLE CENTERLINE (4")	MA PERMANENT RAISED (YELLOW & YELLOW)
TJ 10 FT. WHITE SKIP (6")	MB PERMANENT RAISED (CRYSTAL & RED)
TK 3 FT.-9 FT./SP WHITE MINISKIP (6")	ME SNOWPLOWABLE (YELLOW & YELLOW)
TP YELLOW DIAGONAL (8")	MF SNOWPLOWABLE (CRYSTAL & RED)
TU WHITE DIAGONAL (12")	
TS WHITE GORELINE (12")	
POLYUREA LINES	
VK 3 FT.-9 FT./SP WHITE MINISKIP (6")	
V6 WHITE EDGELINE (6")	
V7 YELLOW EDGELINE (6")	
VJ 10 FT. WHITE SKIP (6")	



I:\2021\2021_PMP_PSH25.dgn

RKK
 P: (919) 578-9500
 8601 Six Forks Road Forum 1 Suite 700 | Raleigh, North Carolina 27615
 NC License No. F-0112
 Engineers | Construction Managers | Planners | Scientists
 www.rkk.com
 Responsive People | Creative Solutions

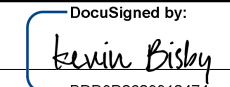
PAVEMENT MARKING DETAIL

TIP NO. R-2511	SHEET NO. PMP-26
APPROVED:  DATE: 10/1/2021	
SEAL 	
DOCUMENT NOT CONSIDERED FINAL UNLESS ALL SIGNATURES COMPLETED	

PAVEMENT MARKING SCHEDULE

- | | |
|--|--|
| THERMOPLASTIC LINES (90 MILS) | THERMOPLASTIC SYMBOLS (90 MILS) |
| T2 WHITE STOPBAR (24") | UA LEFT TURN ARROW |
| T6 WHITE EDGELINE (6") | UB RIGHT TURN ARROW |
| T7 YELLOW EDGELINE (6") | UN 24" YIELD LINE TRIANGLE |
| T11 2 FT. -6 FT./SP WHITE MINISKIP (6") | UT U-TURN ARROW |
| T12 2 FT. -6 FT./SP YELLOW MINISKIP (6") | |
| TA WHITE EDGELINE (4") | |
| TB YELLOW EDGELINE (4") | PAVEMENT MARKERS |
| TI YELLOW DOUBLE CENTERLINE (4") | MA PERMANENT RAISED (YELLOW & YELLOW) |
| TJ 10 FT. WHITE SKIP (6") | MB PERMANENT RAISED (CRYSTAL & RED) |
| TK 3 FT.-9 FT./SP WHITE MINISKIP (6") | ME SNOWPLOWABLE (YELLOW & YELLOW) |
| TP YELLOW DIAGONAL (8") | MF SNOWPLOWABLE (CRYSTAL & RED) |
| TU WHITE DIAGONAL (12") | |
| TS WHITE GORELINE (12") | |
| POLYUREA LINES | |
| VK 3 FT.-9 FT./SP WHITE MINISKIP (6") | |
| V6 WHITE EDGELINE (6") | |
| V7 YELLOW EDGELINE (6") | |
| VJ 10 FT. WHITE SKIP (6") | |

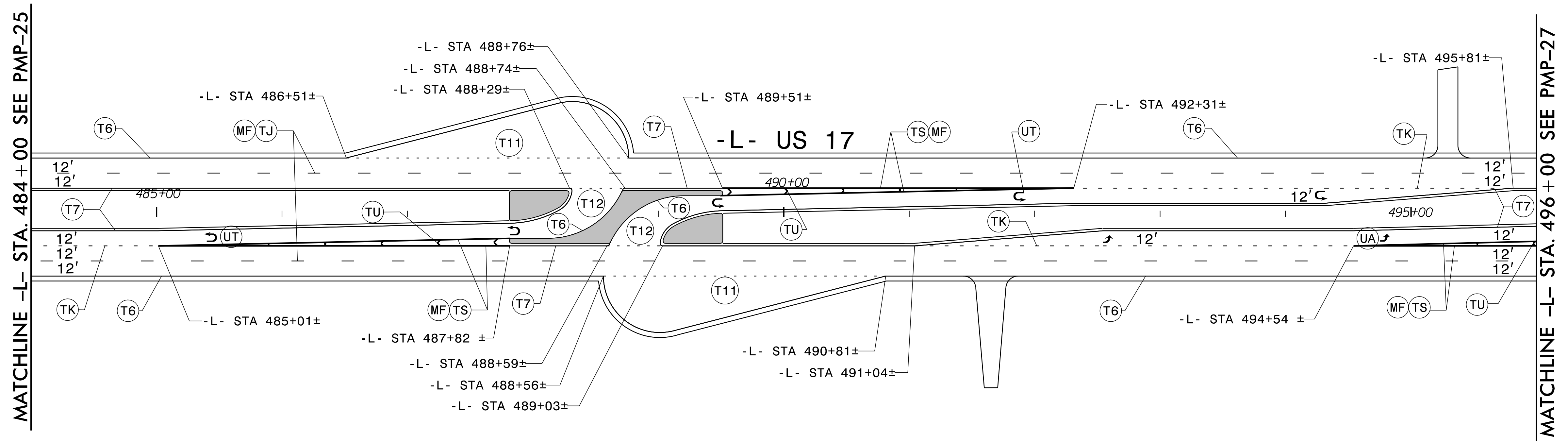

I:\2021\2021_PMP_PSH26.dgn

RKK
 P: (919) 578-9500
 8601 Six Forks Road Forum 1 Suite 700 | Raleigh, North Carolina 27615
 NC License No. F-0112
 Engineers | Construction Managers | Planners | Scientists
 www.rkk.com
 Responsive People | Creative Solutions

PAVEMENT MARKING DETAIL

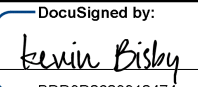
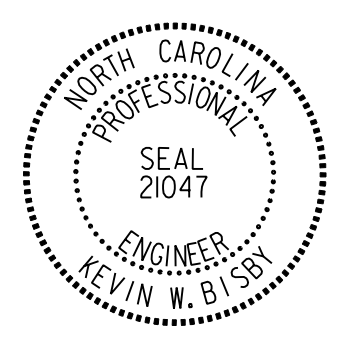
TIP NO. R-2511	SHEET NO. PMP-27
APPROVED:  DATE: 10/1/2021	
SEAL 	
DOCUMENT NOT CONSIDERED FINAL UNLESS ALL SIGNATURES COMPLETED	



PAVEMENT MARKING SCHEDULE

- | | | | |
|--------------------------------------|--------------------------------------|--|------------------------------------|
| THERMOPLASTIC LINES (90 MILS) | | THERMOPLASTIC SYMBOLS (90 MILS) | |
| T2 | WHITE STOPBAR (24") | UA | LEFT TURN ARROW |
| T6 | WHITE EDGELINE (6") | UB | RIGHT TURN ARROW |
| T7 | YELLOW EDGELINE (6") | UN | 24" YIELD LINE TRIANGLE |
| T11 | 2 FT. -6 FT./SP WHITE MINISKIP (6") | UT | U-TURN ARROW |
| T12 | 2 FT. -6 FT./SP YELLOW MINISKIP (6") | | |
| TA | WHITE EDGELINE (4") | PAVEMENT MARKERS | |
| TB | YELLOW EDGELINE (4") | MA | PERMANENT RAISED (YELLOW & YELLOW) |
| TI | YELLOW DOUBLE CENTERLINE (4") | MB | PERMANENT RAISED (CRYSTAL & RED) |
| TJ | 10 FT. WHITE SKIP (6") | ME | SNOWPLOWABLE (YELLOW & YELLOW) |
| TK | 3 FT.-9 FT./SP WHITE MINISKIP (6") | MF | SNOWPLOWABLE (CRYSTAL & RED) |
| TP | YELLOW DIAGONAL (8") | | |
| TU | WHITE DIAGONAL (12") | | |
| TS | WHITE GORELINE (12") | | |
| POLYUREA LINES | | | |
| V6 | WHITE EDGELINE (6") | | |
| V7 | YELLOW EDGELINE (6") | | |
| VJ | 10 FT. WHITE SKIP (6") | | |

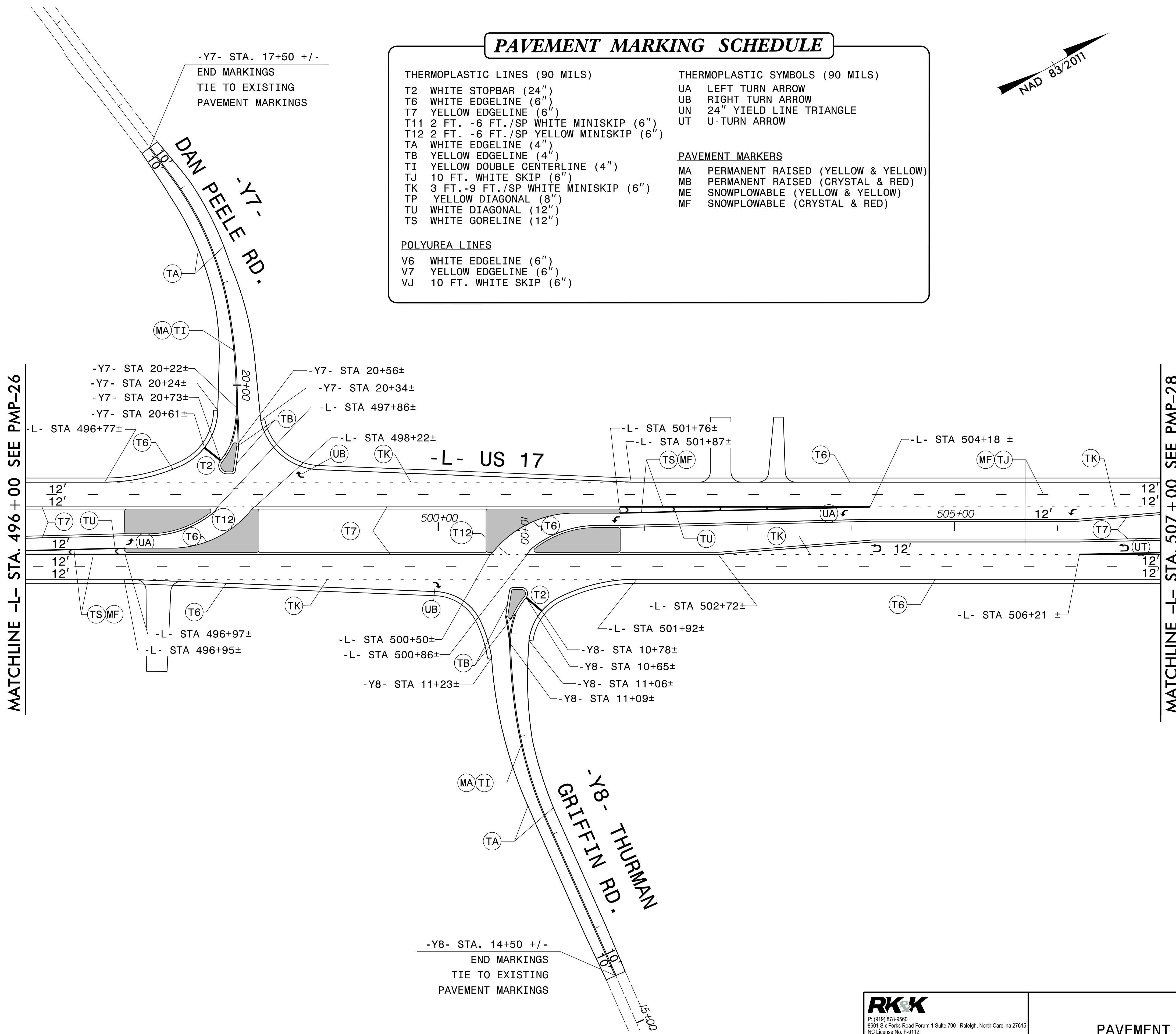

I:\A\2021\2511\2511_PMP_PSHZ7.dgn

RKK
 P: (919) 678-9500
 8601 Six Forks Road Forum 1 Suite 700 | Raleigh, North Carolina 27615
 NC License No. F-0112
 Engineers | Construction Managers | Planners | Scientists
 www.rkk.com
 Responsive People | Creative Solutions

PAVEMENT MARKING DETAIL

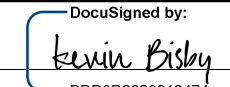
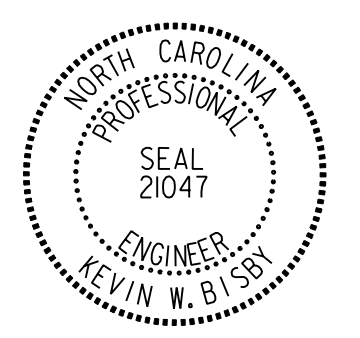
TIP NO. R-2511	SHEET NO. PMP-28
APPROVED:  DATE: 10/1/2021	
SEAL 	
DOCUMENT NOT CONSIDERED FINAL UNLESS ALL SIGNATURES COMPLETED	

PAVEMENT MARKING SCHEDULE

- | | |
|--|--|
| THERMOPLASTIC LINES (90 MILS) | THERMOPLASTIC SYMBOLS (90 MILS) |
| T2 WHITE STOPBAR (24") | UA LEFT TURN ARROW |
| T6 WHITE EDGELINE (6") | UB RIGHT TURN ARROW |
| T7 YELLOW EDGELINE (6") | UN 24" YIELD LINE TRIANGLE |
| T11 2 FT. -6 FT./SP WHITE MINISKIP (6") | UT U-TURN ARROW |
| T12 2 FT. -6 FT./SP YELLOW MINISKIP (6") | |
| TA WHITE EDGELINE (4") | |
| TB YELLOW EDGELINE (4") | |
| TI YELLOW DOUBLE CENTERLINE (4") | PAVEMENT MARKERS |
| TJ 10 FT. WHITE SKIP (6") | MA PERMANENT RAISED (YELLOW & YELLOW) |
| TK 3 FT.-9 FT./SP WHITE MINISKIP (6") | MB PERMANENT RAISED (CRYSTAL & RED) |
| TP YELLOW DIAGONAL (8") | ME SNOWPLOWABLE (YELLOW & YELLOW) |
| TU WHITE DIAGONAL (12") | MF SNOWPLOWABLE (CRYSTAL & RED) |
| TS WHITE GORELINE (12") | |
| POLYUREA LINES | |
| VK 3 FT.-9 FT./SP WHITE MINISKIP (6") | |
| V6 WHITE EDGELINE (6") | |
| V7 YELLOW EDGELINE (6") | |
| VJ 10 FT. WHITE SKIP (6") | |

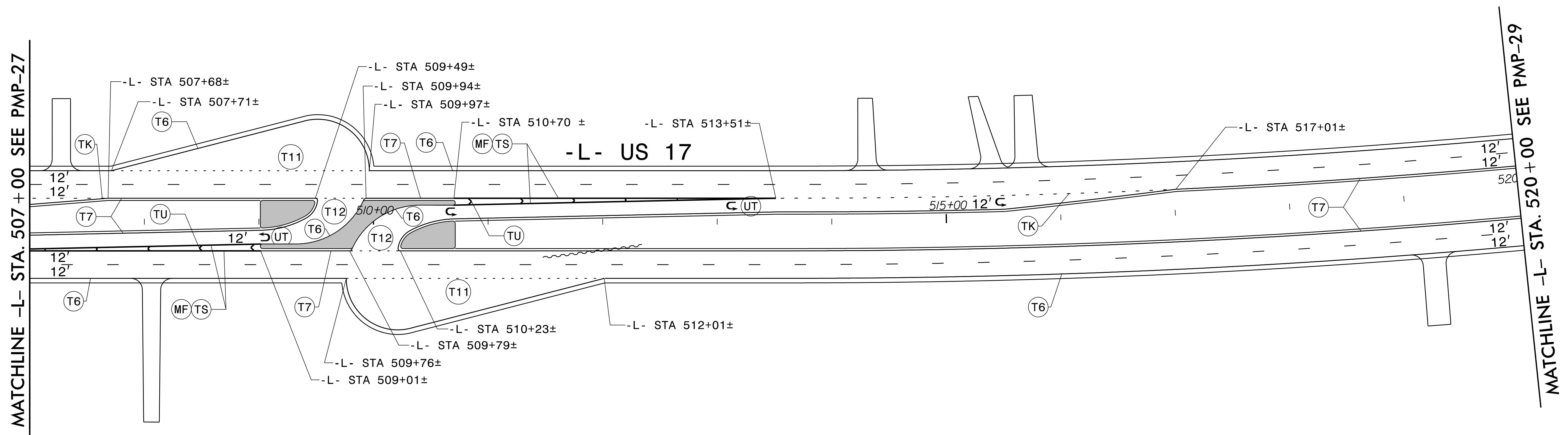

I:\Projects\2021\10\10\2021_PMP_PSH28.dgn

RKK
 P: (919) 578-9500
 8601 Six Forks Road Forum 1 Suite 700 | Raleigh, North Carolina 27615
 NC License No. F-0112
 Engineers | Construction Managers | Planners | Scientists
 www.rkk.com
 Responsive People | Creative Solutions

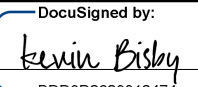
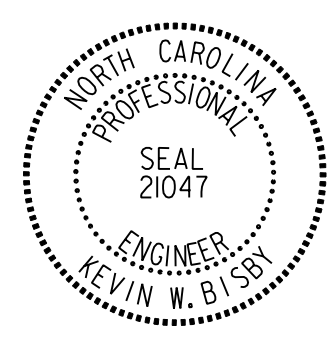
TIP NO. R-2511	SHEET NO. PMP-29
APPROVED:  DATE: 10/1/2021	
SEAL 	
DOCUMENT NOT CONSIDERED FINAL UNLESS ALL SIGNATURES COMPLETED	

PAVEMENT MARKING SCHEDULE

THERMOPLASTIC LINES (90 MILS)

- T2 WHITE STOPBAR (24")
- T6 WHITE EDGELINE (6")
- T7 YELLOW EDGELINE (6")
- T11 2 FT. -6 FT./SP WHITE MINISKIP (6")
- T12 2 FT. -6 FT./SP YELLOW MINISKIP (6")
- TA WHITE EDGELINE (4")
- TB YELLOW EDGELINE (4")
- TI YELLOW DOUBLE CENTERLINE (4")
- TJ 10 FT. WHITE SKIP (6")
- TK 3 FT.-9 FT./SP WHITE MINISKIP (6")
- TP YELLOW DIAGONAL (8")
- TU WHITE DIAGONAL (12")
- TS WHITE GORELINE (12")

THERMOPLASTIC SYMBOLS (90 MILS)

- UA LEFT TURN ARROW
- UB RIGHT TURN ARROW
- UN 24" YIELD LINE TRIANGLE
- UT U-TURN ARROW

PAVEMENT MARKERS

- MA PERMANENT RAISED (YELLOW & YELLOW)
- MB PERMANENT RAISED (CRYSTAL & RED)
- ME SNOWPLOWABLE (YELLOW & YELLOW)
- MF SNOWPLOWABLE (CRYSTAL & RED)

POLYUREA LINES

- VK 3 FT.-9 FT./SP WHITE MINISKIP (6")
- V6 WHITE EDGELINE (6")
- V7 YELLOW EDGELINE (6")
- VJ 10 FT. WHITE SKIP (6")

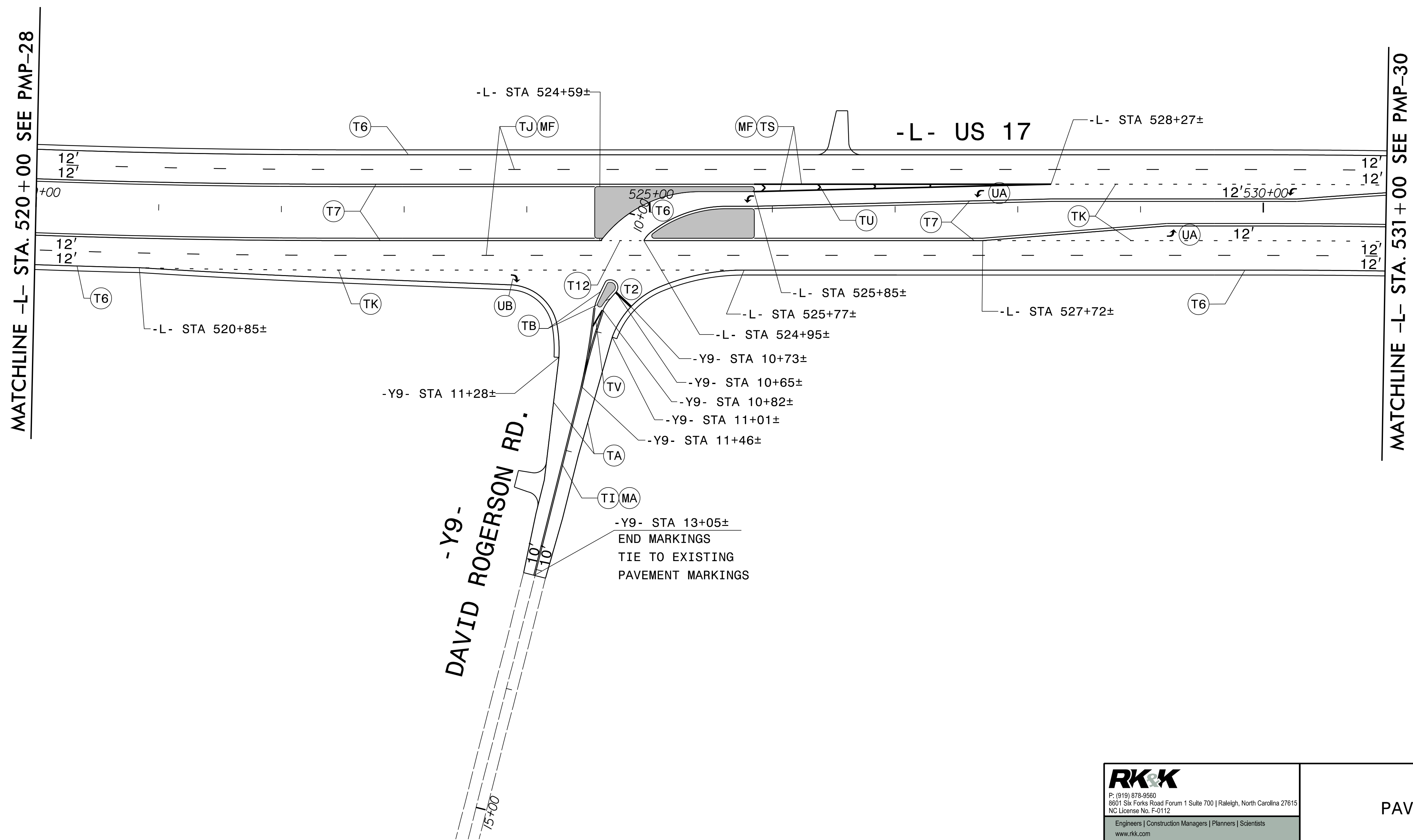

10/1/2021 10:41:11 AM PMP_PSH29.dgn

RKK
 P: (919) 578-9500
 8601 Six Forks Road Forum 1 Suite 700 | Raleigh, North Carolina 27615
 NC License No. F-0112
 Engineers | Construction Managers | Planners | Scientists
 www.rkk.com
 Responsive People | Creative Solutions

PAVEMENT MARKING DETAIL

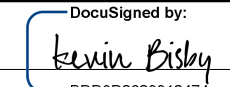
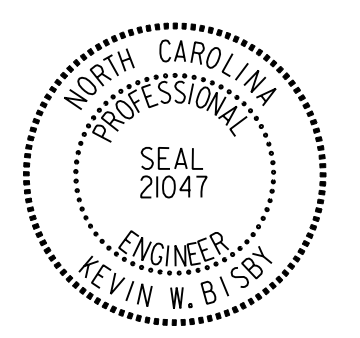
TIP NO. R-2511	SHEET NO. PMP-30
APPROVED:  DATE: 10/1/2021	
SEAL 	
DOCUMENT NOT CONSIDERED FINAL UNLESS ALL SIGNATURES COMPLETED	

PAVEMENT MARKING SCHEDULE

THERMOPLASTIC LINES (90 MILS)	THERMOPLASTIC SYMBOLS (90 MILS)
T2 WHITE STOPBAR (24")	UA LEFT TURN ARROW
T6 WHITE EDGELINE (6")	UB RIGHT TURN ARROW
T7 YELLOW EDGELINE (6")	UN 24" YIELD LINE TRIANGLE
T11 2 FT. -6 FT./SP WHITE MINISKIP (6")	UT U-TURN ARROW
T12 2 FT. -6 FT./SP YELLOW MINISKIP (6")	
TA WHITE EDGELINE (4")	
TB YELLOW EDGELINE (4")	
TI YELLOW DOUBLE CENTERLINE (4")	
TJ 10 FT. WHITE SKIP (6")	
TK 3 FT.-9 FT./SP WHITE MINISKIP (6")	
TP YELLOW DIAGONAL (8")	
TU WHITE DIAGONAL (12")	
TS WHITE GORELINE (12")	
	PAVEMENT MARKERS
	MA PERMANENT RAISED (YELLOW & YELLOW)
	MB PERMANENT RAISED (CRYSTAL & RED)
	ME SNOWPLOWABLE (YELLOW & YELLOW)
	MF SNOWPLOWABLE (CRYSTAL & RED)
POLYUREA LINES	
VK 3 FT.-9 FT./SP WHITE MINISKIP (6")	
V6 WHITE EDGELINE (6")	
V7 YELLOW EDGELINE (6")	
VJ 10 FT. WHITE SKIP (6")	

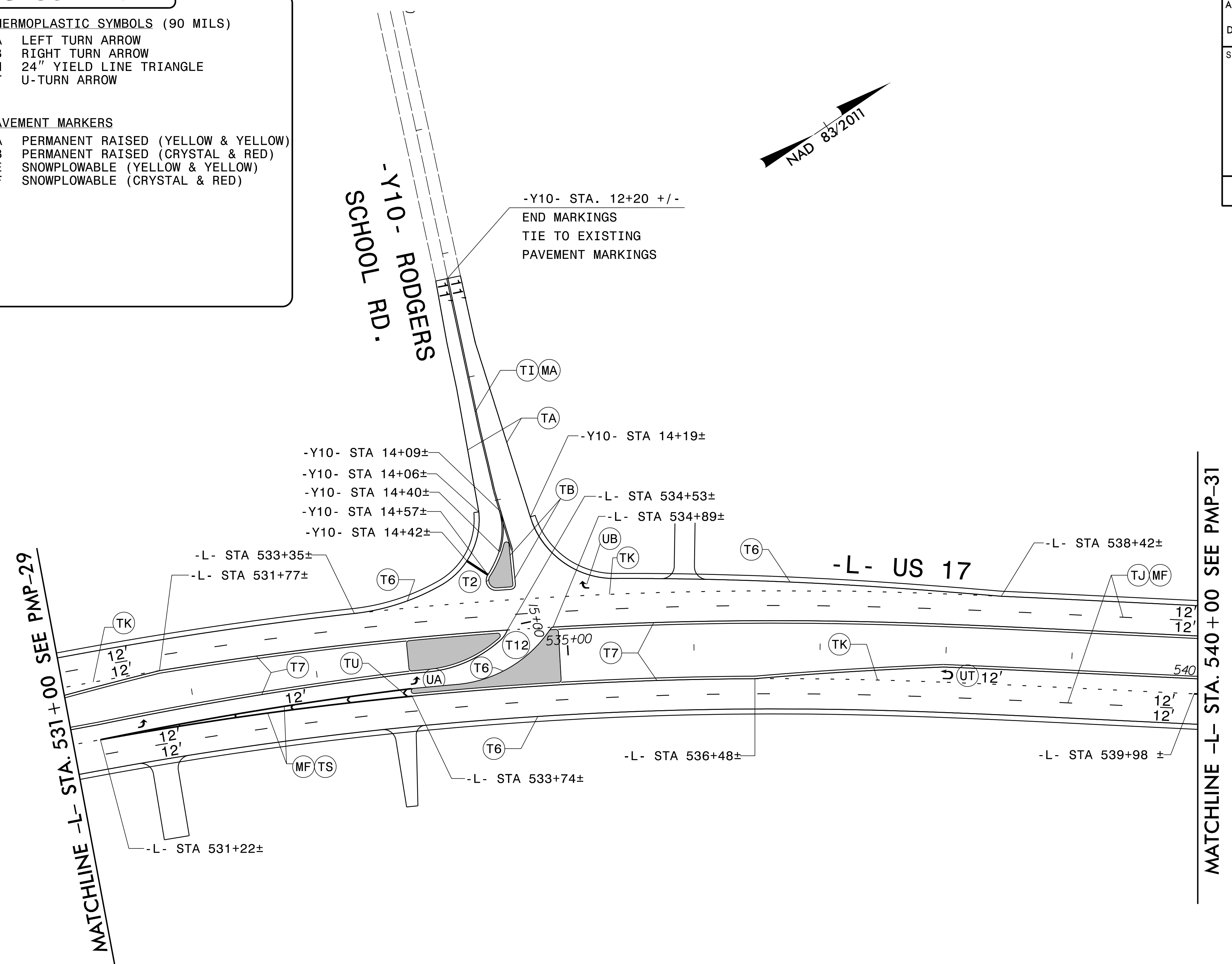

I:\2021\2021_PMP_PSH30.dgn

RKK
 P: (919) 578-9500
 8601 Six Forks Road Forum 1 Suite 700 | Raleigh, North Carolina 27615
 NC License No. F-0112
 Engineers | Construction Managers | Planners | Scientists
 www.rkk.com
 Responsive People | Creative Solutions

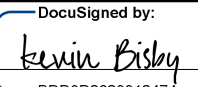
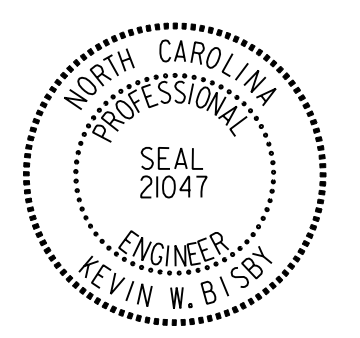
TIP NO. R-2511	SHEET NO. PMP-31
APPROVED:  DATE: 10/1/2021	
SEAL 	
DOCUMENT NOT CONSIDERED FINAL UNLESS ALL SIGNATURES COMPLETED	

PAVEMENT MARKING SCHEDULE

- | | |
|--|--|
| THERMOPLASTIC LINES (90 MILS) | THERMOPLASTIC SYMBOLS (90 MILS) |
| T2 WHITE STOPBAR (24") | UA LEFT TURN ARROW |
| T6 WHITE EDGELINE (6") | UB RIGHT TURN ARROW |
| T7 YELLOW EDGELINE (6") | UN 24" YIELD LINE TRIANGLE |
| T11 2 FT. -6 FT./SP WHITE MINISKIP (6") | UT U-TURN ARROW |
| T12 2 FT. -6 FT./SP YELLOW MINISKIP (6") | |
| TA WHITE EDGELINE (4") | |
| TB YELLOW EDGELINE (4") | PAVEMENT MARKERS |
| TI YELLOW DOUBLE CENTERLINE (4") | MA PERMANENT RAISED (YELLOW & YELLOW) |
| TJ 10 FT. WHITE SKIP (6") | MB PERMANENT RAISED (CRYSTAL & RED) |
| TK 3 FT.-9 FT./SP WHITE MINISKIP (6") | ME SNOWPLOWABLE (YELLOW & YELLOW) |
| TP YELLOW DIAGONAL (8") | MF SNOWPLOWABLE (CRYSTAL & RED) |
| TU WHITE DIAGONAL (12") | |
| TS WHITE GORELINE (12") | |
| POLYUREA LINES | |
| VK 3 FT.-9 FT./SP WHITE MINISKIP (6") | |
| V6 WHITE EDGELINE (6") | |
| V7 YELLOW EDGELINE (6") | |
| VJ 10 FT. WHITE SKIP (6") | |

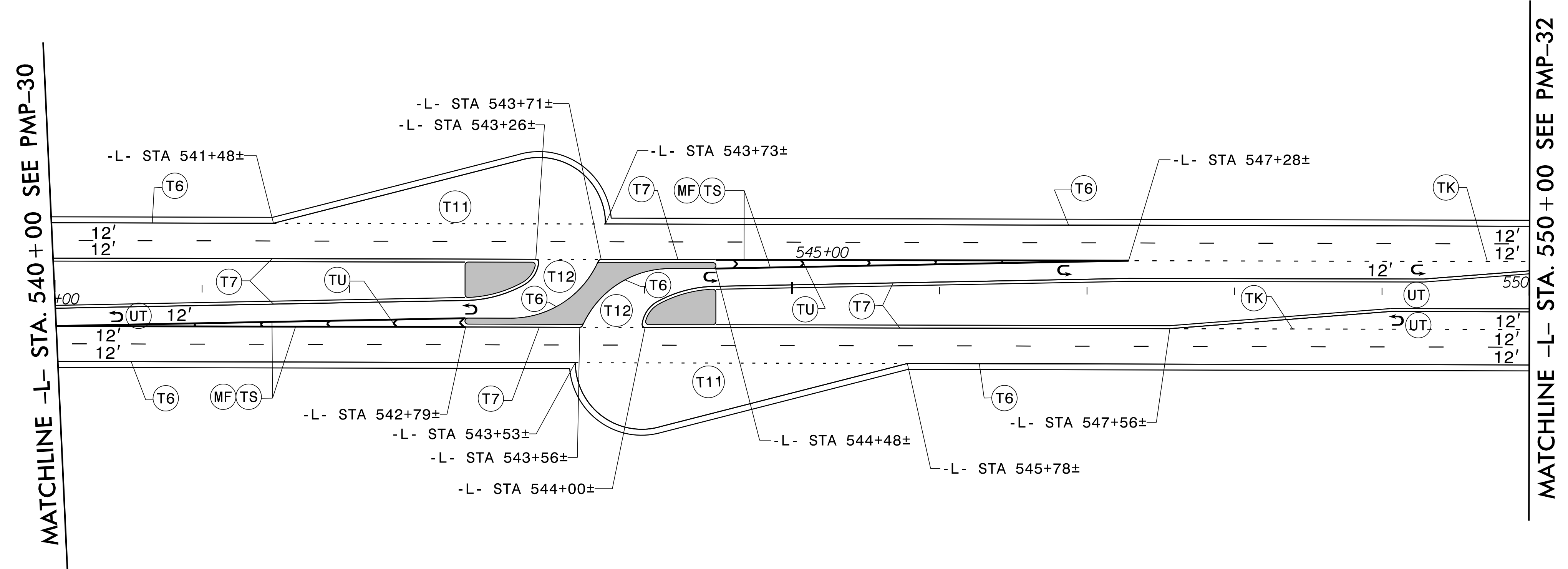
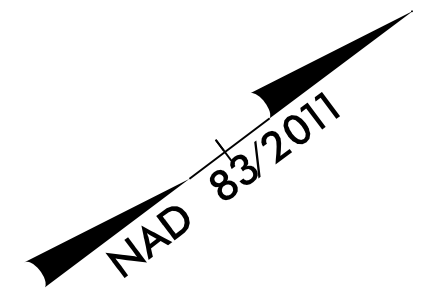

10/1/2021
PMP_PSH31.dgn
K. Bly

RKK
P: (919) 578-9500
8601 Six Forks Road Forum 1 Suite 700 | Raleigh, North Carolina 27615
NC License No. F-0112
www.rkk.com
Responsive People | Creative Solutions

PAVEMENT MARKING DETAIL

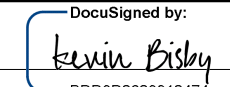
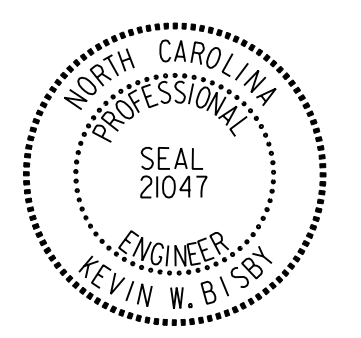
TIP NO. R-2511	SHEET NO. PMP-32
APPROVED:  DocuSigned by: Kevin B. Bly B00802828912472	
DATE: 10/1/2021	
SEAL 	
DOCUMENT NOT CONSIDERED FINAL UNLESS ALL SIGNATURES COMPLETED	

PAVEMENT MARKING SCHEDULE

THERMOPLASTIC LINES (90 MILS)	THERMOPLASTIC SYMBOLS (90 MILS)
T2 WHITE STOPBAR (24")	UA LEFT TURN ARROW
T6 WHITE EDGELINE (6")	UB RIGHT TURN ARROW
T7 YELLOW EDGELINE (6")	UN 24" YIELD LINE TRIANGLE
T11 2 FT. -6 FT./SP WHITE MINISKIP (6")	UT U-TURN ARROW
T12 2 FT. -6 FT./SP YELLOW MINISKIP (6")	
TA WHITE EDGELINE (4")	PAVEMENT MARKERS
TB YELLOW EDGELINE (4")	MA PERMANENT RAISED (YELLOW & YELLOW)
TI YELLOW DOUBLE CENTERLINE (4")	MB PERMANENT RAISED (CRYSTAL & RED)
TJ 10 FT. WHITE SKIP (6")	ME SNOWPLOWABLE (YELLOW & YELLOW)
TK 3 FT.-9 FT./SP WHITE MINISKIP (6")	MF SNOWPLOWABLE (CRYSTAL & RED)
TP YELLOW DIAGONAL (8")	
TU WHITE DIAGONAL (12")	
TS WHITE GORELINE (12")	
POLYUREA LINES	
VK 3 FT.-9 FT./SP WHITE MINISKIP (6")	
V6 WHITE EDGELINE (6")	
V7 YELLOW EDGELINE (6")	
VJ 10 FT. WHITE SKIP (6")	

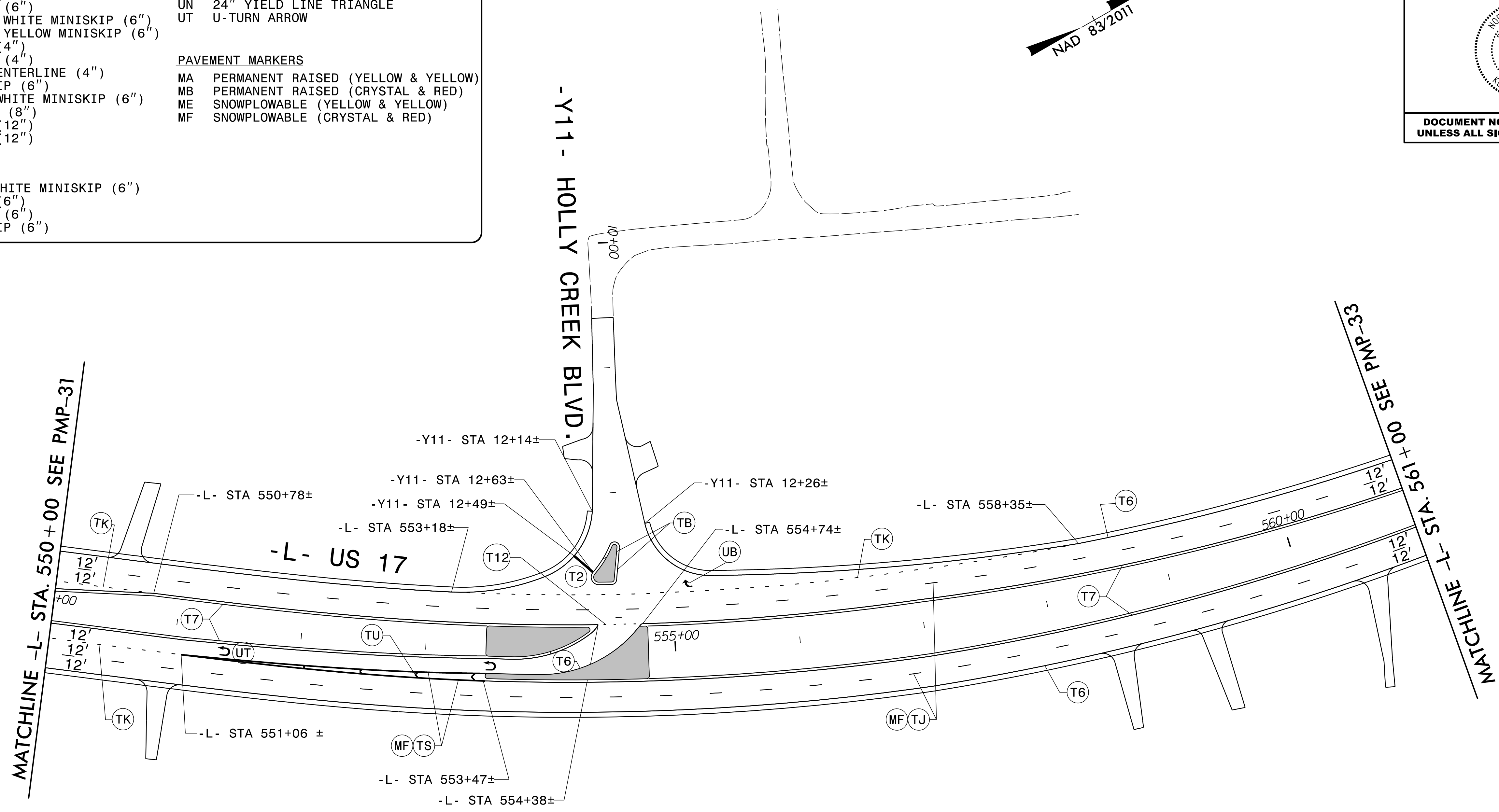

10/1/2021
R-2511_PMP_PSH32.dgn
K.Bly

RKK
P: (919) 578-9500
8601 Six Forks Road Forum 1 Suite 700 | Raleigh, North Carolina 27615
NC License No. F-0112
Engineers | Construction Managers | Planners | Scientists
www.rkk.com
Responsive People | Creative Solutions

PAVEMENT MARKING DETAIL

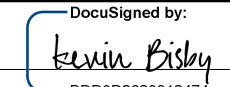
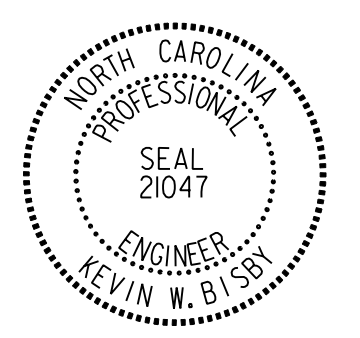
TIP NO. R-2511	SHEET NO. PMP-33
APPROVED:  DATE: 10/1/2021	
SEAL 	
DOCUMENT NOT CONSIDERED FINAL UNLESS ALL SIGNATURES COMPLETED	

PAVEMENT MARKING SCHEDULE

THERMOPLASTIC LINES (90 MILS)	THERMOPLASTIC SYMBOLS (90 MILS)
T2 WHITE STOPBAR (24")	UA LEFT TURN ARROW
T6 WHITE EDGELINE (6")	UB RIGHT TURN ARROW
T7 YELLOW EDGELINE (6")	UN 24" YIELD LINE TRIANGLE
T11 2 FT. -6 FT./SP WHITE MINISKIP (6")	UT U-TURN ARROW
T12 2 FT. -6 FT./SP YELLOW MINISKIP (6")	
TA WHITE EDGELINE (4")	
TB YELLOW EDGELINE (4")	PAVEMENT MARKERS
TI YELLOW DOUBLE CENTERLINE (4")	MA PERMANENT RAISED (YELLOW & YELLOW)
TJ 10 FT. WHITE SKIP (6")	MB PERMANENT RAISED (CRYSTAL & RED)
TK 3 FT.-9 FT./SP WHITE MINISKIP (6")	ME SNOWPLOWABLE (YELLOW & YELLOW)
TP YELLOW DIAGONAL (8")	MF SNOWPLOWABLE (CRYSTAL & RED)
TU WHITE DIAGONAL (12")	
TS WHITE GORELINE (12")	
POLYUREA LINES	
VK 3 FT.-9 FT./SP WHITE MINISKIP (6")	
V6 WHITE EDGELINE (6")	
V7 YELLOW EDGELINE (6")	
VJ 10 FT. WHITE SKIP (6")	

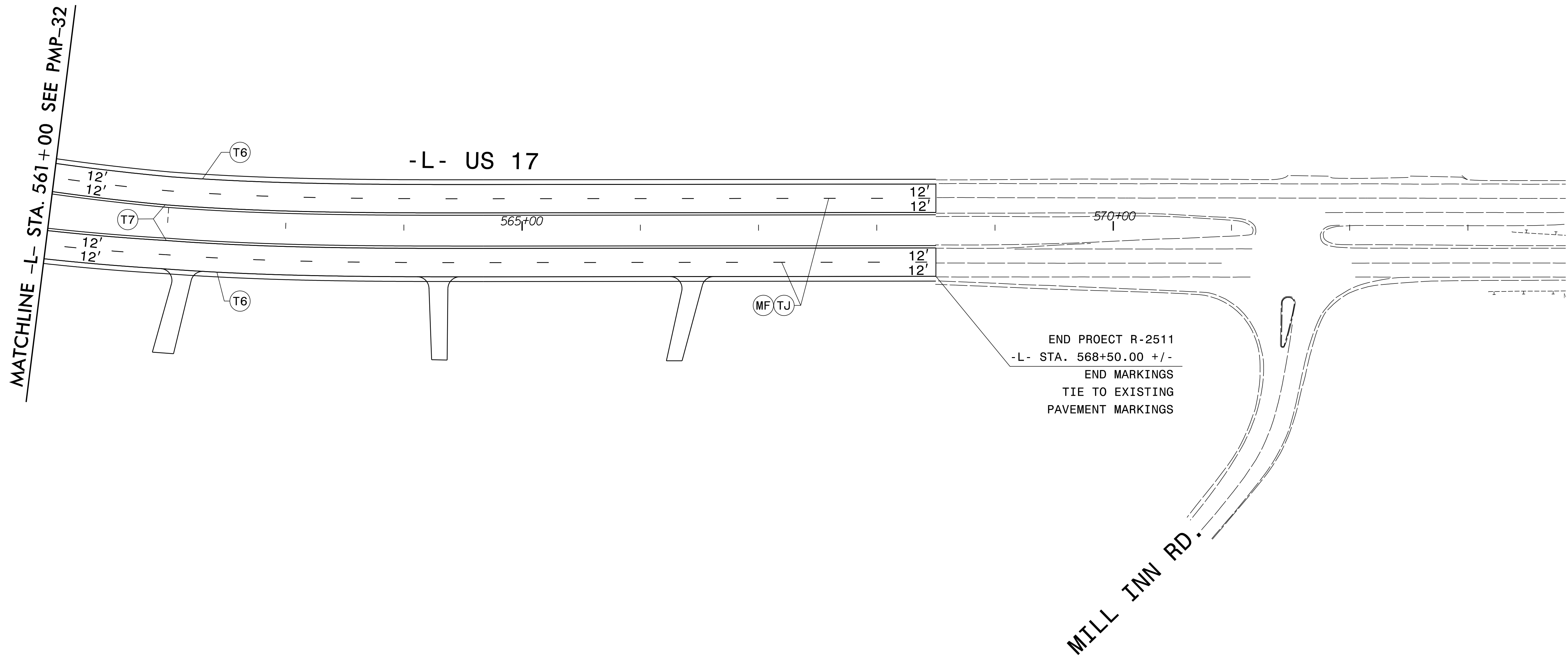
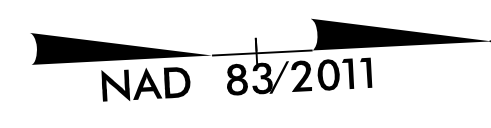

10/1/2021
PMP_PSH33.dgn
kbs

RKK
P: (919) 578-9500
8601 Six Forks Road Forum 1 Suite 700 | Raleigh, North Carolina 27615
NC License No. F-0112
Engineers | Construction Managers | Planners | Scientists
www.rkk.com
Responsive People | Creative Solutions

PAVEMENT MARKING DETAIL