

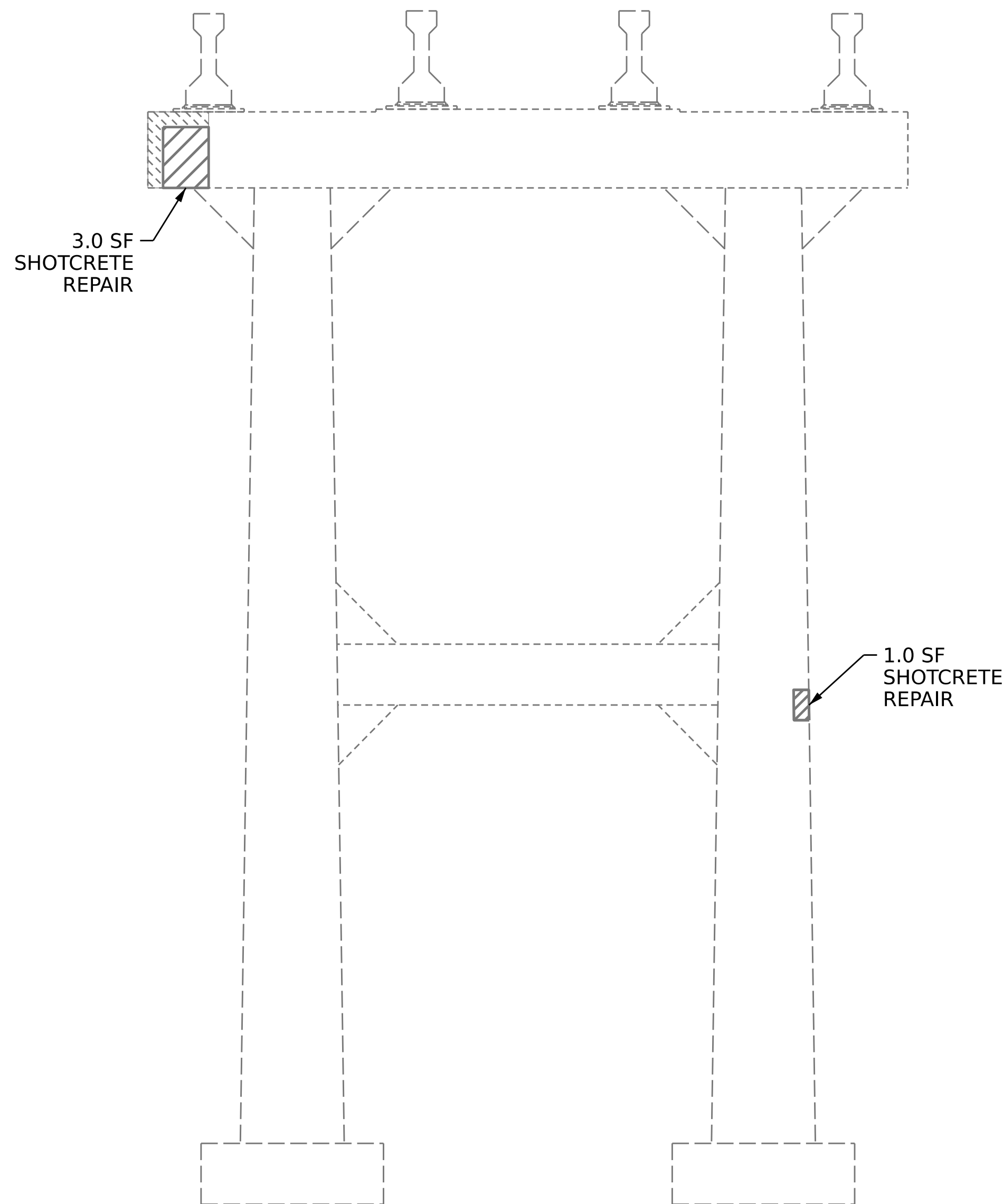

SPAN A  
SPAN B

**BOTTOM OF CAP**



**ELEVATION**



**BOTTOM OF STRUT**

SPAN B | SPAN A

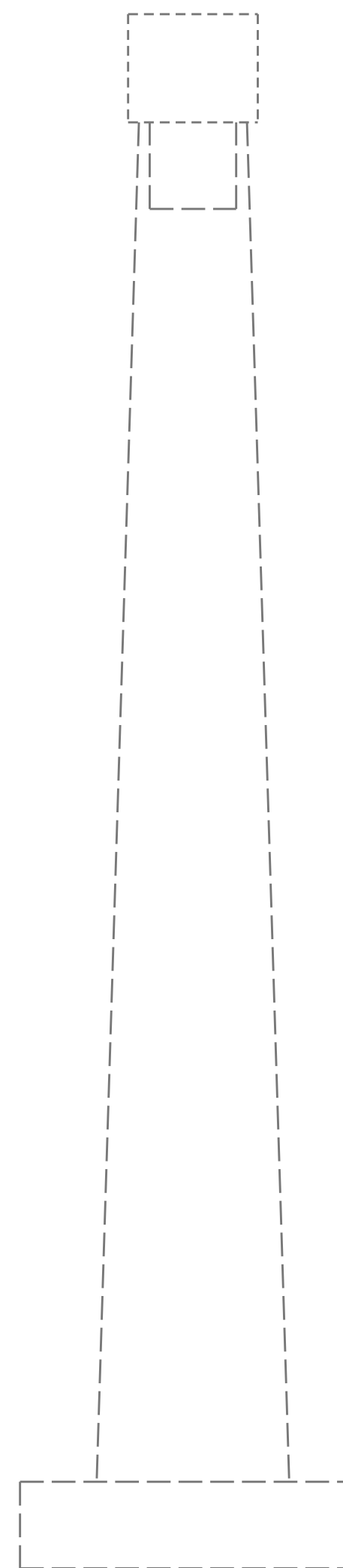

**END VIEW**

**AS-BUILT REPAIR QUANTITY TABLE**

REPAIRS BENT 1 - SPAN B	QUANTITIES			
	ESTIMATE		ACTUAL	
SHOTCRETE REPAIRS	AREA SF	VOLUME CF	AREA SF	VOLUME CF
CAP	3.0	1.5		
COLUMN	1.0	0.5		
STRUT	0	0		
CONCRETE REPAIRS	AREA SF	VOLUME CF	AREA SF	VOLUME CF
CAP	0	0		
COLUMN	0	0		
STRUT	0	0		

VALUES IN CHART REPRESENT ESTIMATED REPAIR TOTALS AFTER REMOVAL OF UNSOUND CONCRETE, MIN. OF 1" BEHIND REBAR AND MIN. 1" CLEAR TO SAWCUT. SEE REPAIR DETAILS.

**NOTES**

REPAIR LOCATIONS AND ESTIMATE OF QUANTITIES ARE GIVEN BASED ON THE BEST INFORMATION AVAILABLE. IF ADDITIONAL REPAIRS NOT SHOWN ON THE DRAWINGS ARE DEEMED NECESSARY BY THE ENGINEER, THE ENGINEER SHALL NOTE ON THE DRAWINGS THE APPROXIMATE LOCATION AND DESCRIPTION OF THE REPAIRS AND ENTER THE ACTUAL QUANTITIES INTO THE AS-BUILT REPAIR QUANTITY TABLE.

CONCRETE REPAIRS MAYBE SUBSTITUTED IN LIEU OF SHOTCRETE REPAIRS WITH THE APPROVAL OF THE ENGINEER.

FOR "SHOTCRETE REPAIRS", SEE SPECIAL PROVISIONS.

- SHOTCRETE REPAIR AREA
- CONCRETE REPAIR AREA
- AREA PREVIOUSLY ACCOUNTED FOR ON ADJACENT FACE

PROJECT NO. **15BPR.49**  
**WAKE** COUNTY  
 BRIDGE NO. **910240**

SHEET 3 OF 12

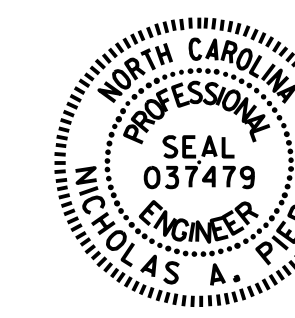

DocuSigned by:  
 Nicholas Pierce  
 151108434208485  
 01/21/2022

STATE OF NORTH CAROLINA  
 DEPARTMENT OF TRANSPORTATION  
 RALEIGH

**SUBSTRUCTURE REPAIRS**

**BENT 1  
 SPAN B FACE**

REVISIONS						SHEET NO.
NO.	BY:	DATE:	NO.	BY:	DATE:	TOTAL SHEETS
1			3			73
2			4			

DOCUMENT NOT CONSIDERED FINAL UNLESS ALL SIGNATURES COMPLETED

DRAWN BY : D.A. CANTRELL DATE : 2/2019  
 CHECKED BY : N.A. PIERCE DATE : 4/2019  
 DESIGN ENGINEER OF RECORD : N.A. PIERCE DATE : 11/2021