

MECHANICAL STRAND SPLICE ASSEMBLY
(ASSEMBLIES MAY VARY DEPENDING ON MANUFACTURER)

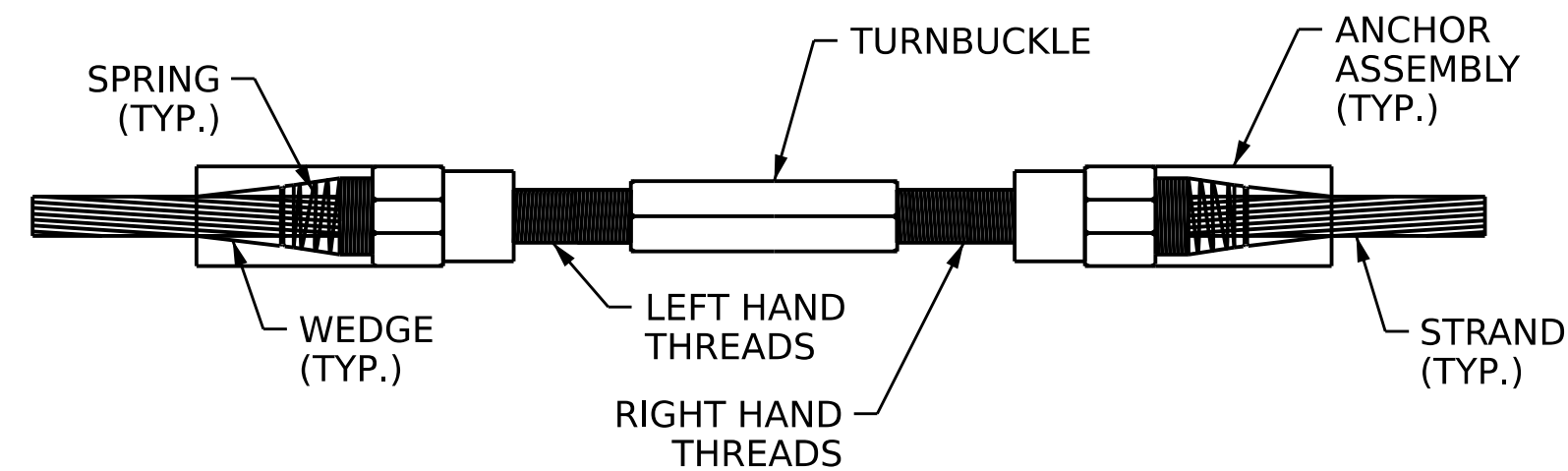

STRAND SPLICE DETAIL

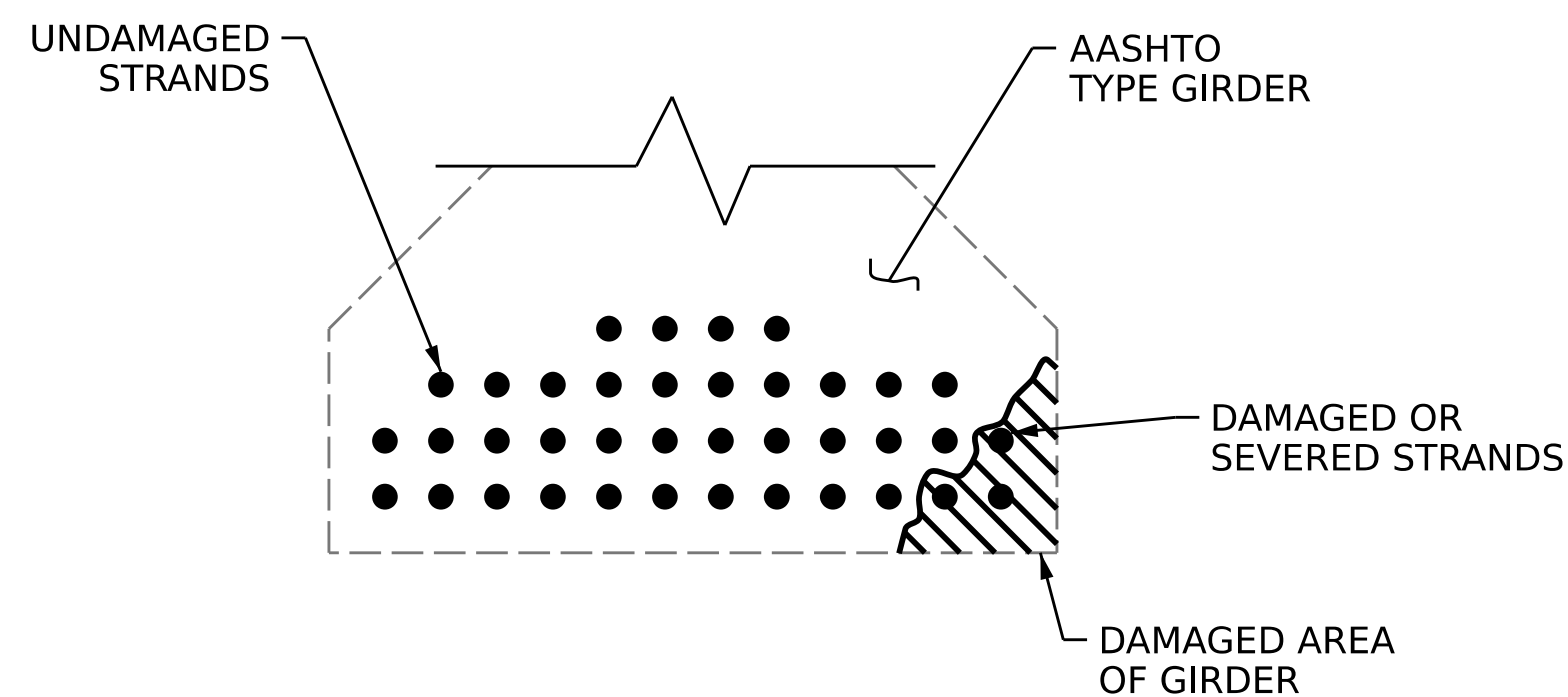

SECTION VIEW OF DAMAGED GIRDER

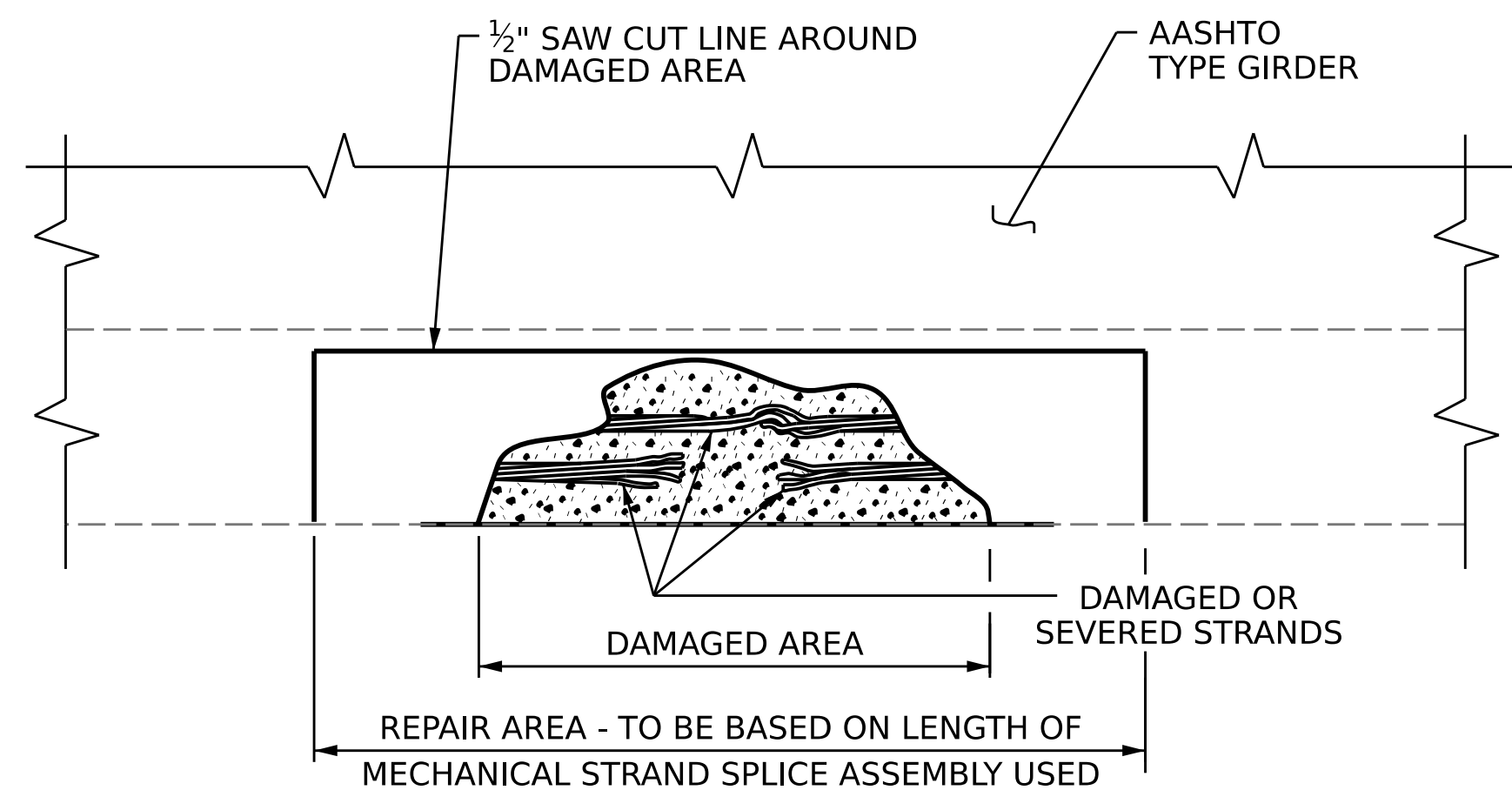

ELEVATION VIEW OF DAMAGED GIRDER

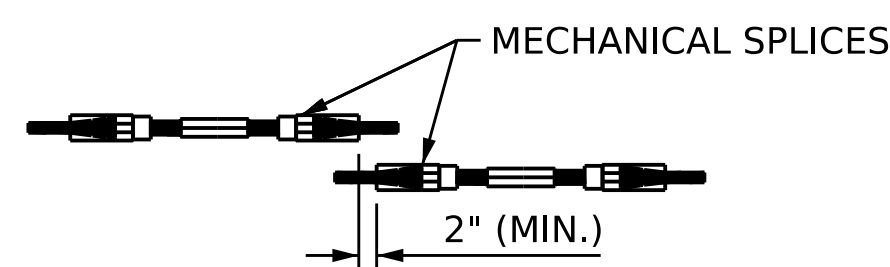

STRAND REPAIR DETAILS

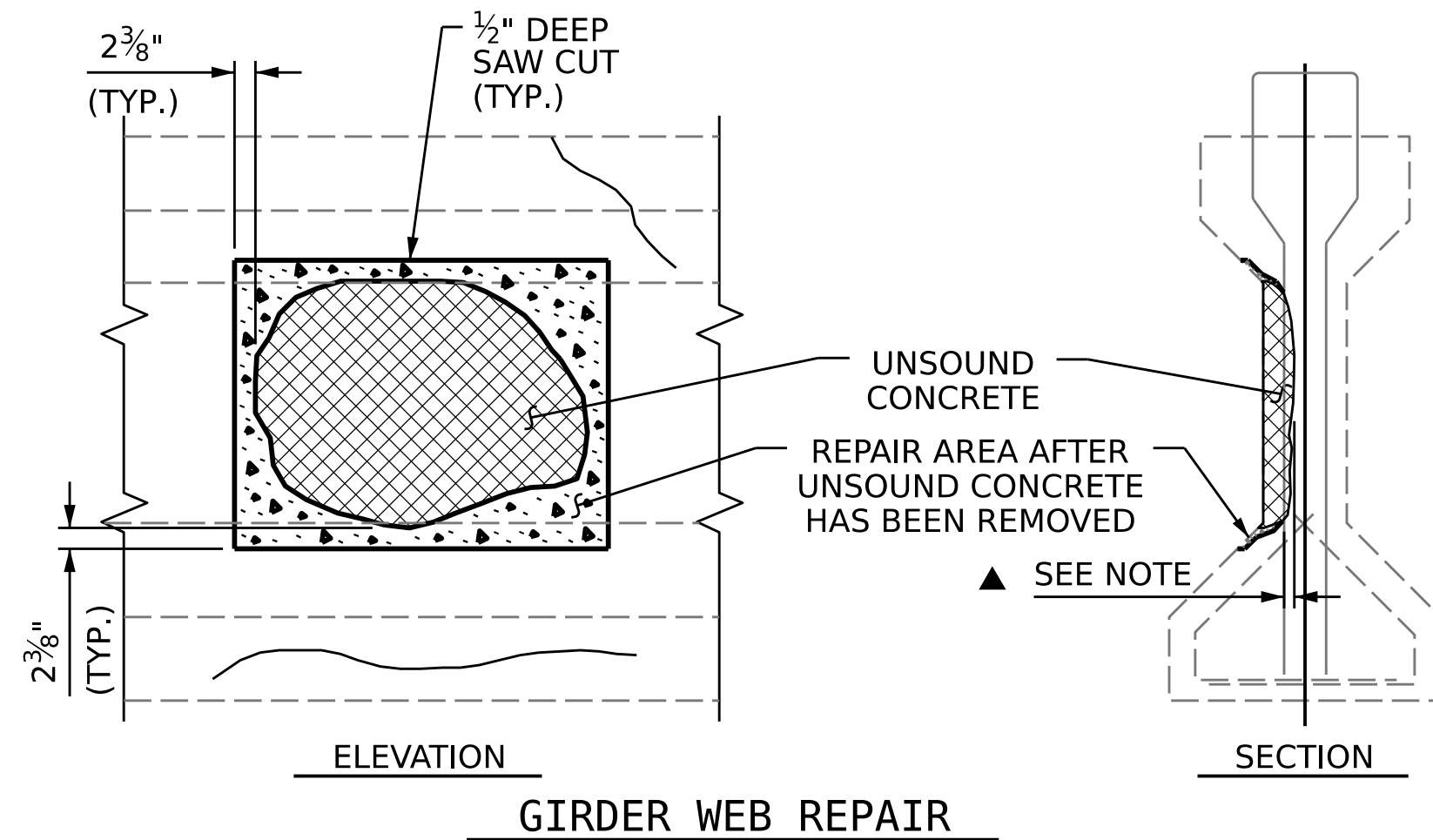

GIRDER WEB REPAIR

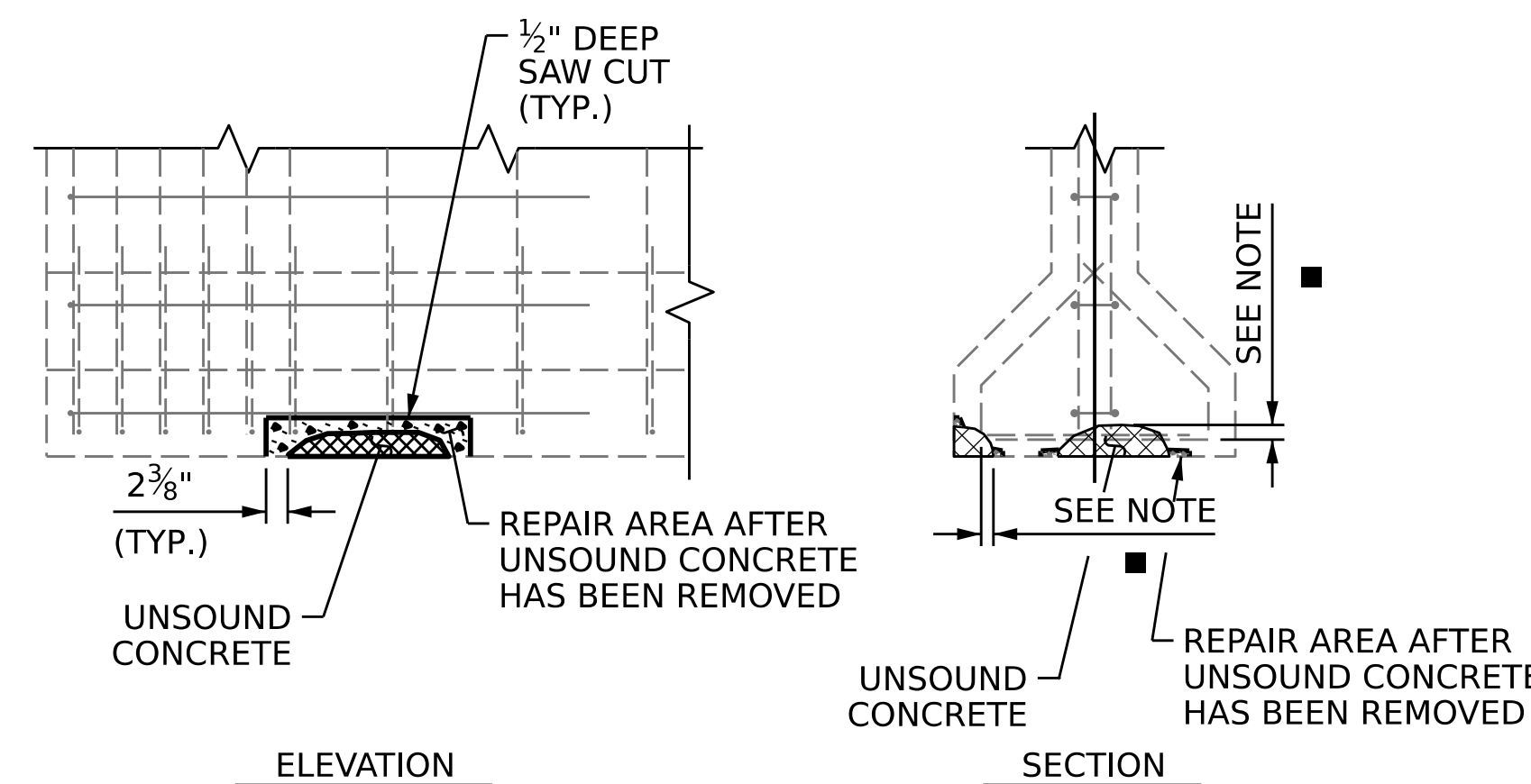

GIRDER FLANGE REPAIR

PRESTRESSED GIRDER REPAIR

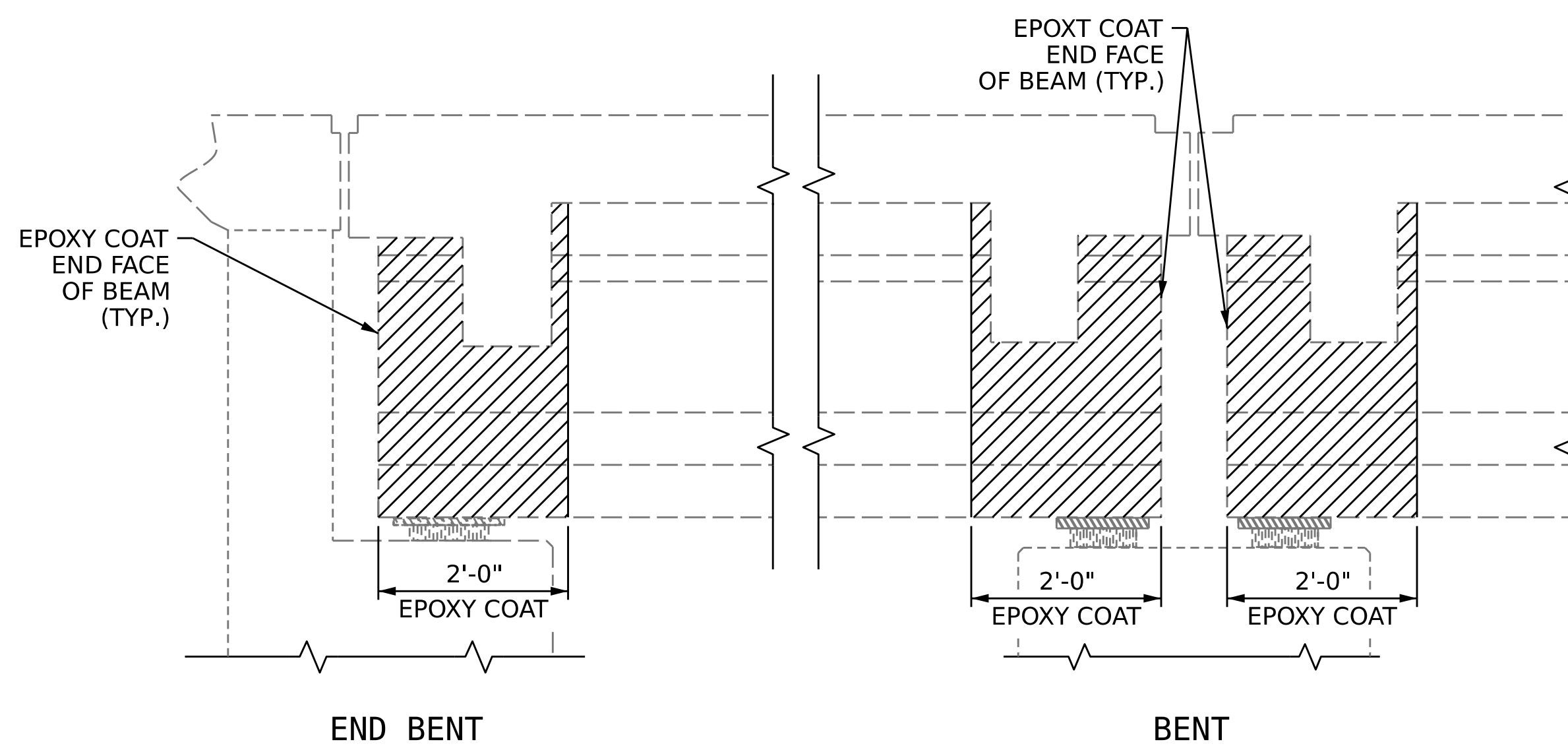
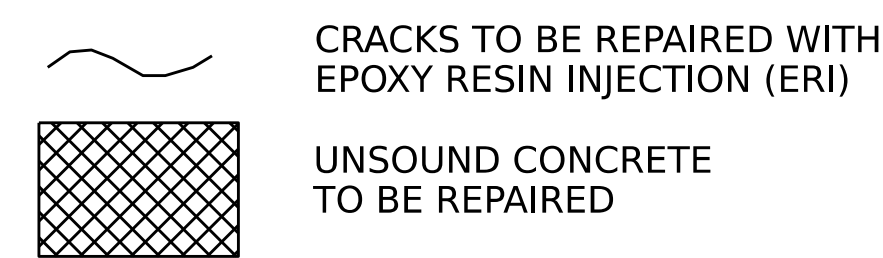

LIMITS OF EPOXY COATING

NOTES

- PREPACKAGED MATERIAL IS REQUIRED.
- CONSULT WITH THE ENGINEER TO DETERMINE PRELOADING REQUIREMENTS WHEN REPAIR IS WITHIN THE CENTER REGION OF THE BEAM (0.25L TO 0.75L).
- FOR REPAIRS OVER TRAFFIC AND SHALLOW REPAIRS THAT DO NOT ENGAGE REINFORCEMENT, ANCHOR PATCH MATERIAL USING 1/4" GALVANIZED BOLTS, EPOXY ANCHORED WITH 2" EMBEDMENT. PLACE BOLTS IN A 6" GRID. USE A LATEX OR EPOXY PATCH MATERIAL FOR IMPROVED BOND. USE EXTREME CARE TO NOT DAMAGE STRANDS.
- FOR PRESTRESSED CONCRETE GIRDER REPAIRS, SEE SPECIAL PROVISIONS.
- FOR EPOXY RESIN INJECTION (ERI), SEE SPECIAL PROVISIONS.
- FOR EPOXY COATING CONCRETE GIRDER ENDS, SEE SPECIAL PROVISIONS.

PRESTRESSED GIRDER REPAIR SEQUENCE

- SOUND CONCRETE TO DETERMINE EXTENTS OF REPAIR LOCATION.
- REMOVE SURFACE CONCRETE TO VERIFY THAT SAWCUT DEPTH WILL NOT DAMAGE EXISTING REINFORCING STEEL. SAW CUT AROUND REPAIR AREA TO A NOMINAL DEPTH OF 1/2".
- REMOVE CONCRETE WITHIN SAW CUT AREA TO MINIMUM 1/2" DEPTH. IF CONCRETE IS DAMAGED BEYOND THE ORIGINAL SAW CUT, A NEW SAW CUT IS REQUIRED.
- IF MORE THAN HALF THE CIRCUMFERENCE OF A REINFORCING BAR IS EXPOSED DURING THIS PROCESS, REMOVE ADDITIONAL CONCRETE TO 1" BEHIND THE BAR. THIS DOES NOT APPLY TO PRESTRESSED STRANDS.
- ALL UNSOUND CONCRETE MUST BE REMOVED, HOWEVER, PRESTRESSED STRANDS SHOULD NOT BE DISTURBED UNLESS ABSOLUTELY NECESSARY. USE EXTREME CARE TO NOT DAMAGE STRANDS.
- USE A WIRE BRUSH TO CLEAN ALL EXPOSED REINFORCING BARS AND PRESTRESSED STRANDS. FOR BARS WITH MORE THAN 10% SECTION LOSS, SPLICE AND SECURELY TIE SUPPLEMENTAL REINFORCING BARS AS NEEDED. NOTE AND PROVIDE DETAILED DOCUMENTATION, INCLUDING LOCATION AND SEVERITY, OF ALL DAMAGE TO PRESTRESSED STRANDS THAT EXCEEDS 10% SECTION LOSS. IF FIVE (5) OR MORE STRANDS ARE DAMAGED, NOTIFY THE ENGINEER PRIOR TO PLACEMENT OF REPAIR MATERIAL.
- REMOVE ALL LOOSE OR WEAKENED MATERIAL THEN CLEAN THE REPAIR AREA OF DIRT, GREASE, OIL, AND FOREIGN MATTER.
- PREPARE SURFACE AND PLACE APPROVED REPAIR MATERIAL ACCORDING TO MANUFACTURER'S RECOMMENDATIONS. MAXIMUM AGGREGATE SIZE FOR REPAIR MATERIAL SHALL NOT EXCEED 2/3 THE MINIMUM REPAIR DEPTH.

PRESTRESSED GIRDER STRAND REPAIR SEQUENCE

- REMOVE LIVE LOAD FROM REPAIR AREA BY EITHER CLOSING BRIDGE TO TRAFFIC OR SHIFTING TRAFFIC AWAY FROM REPAIR AREA.
- MEASURE OUT THE AREA NEEDED TO HAVE ADEQUATE ROOM TO SPLICE THE BROKEN OR DAMAGED STRAND. IF MULTIPLE STRANDS ARE BROKEN ADJACENT TO ONE ANOTHER THEN THE SPLICES SHALL BE STAGGERED. SEE "SPLICE OFFSET" ABOVE. AFTER YOU HAVE DETERMINED THE REPAIR AREA NEEDED, SAW CUT A MINIMUM OF 1/2" AT RIGHT ANGLES AROUND THE DAMAGED AREA. CHIP OUT REST OF CONCRETE TO A SUFFICIENT REPAIR DEPTH.
- SPLICE STRANDS USING THE MECHANICAL SPLICE STRAND ASSEMBLY AND TENSION TO REQUIRED FORCE PER THE MANUFACTURER'S GUIDELINES.
- PATCH REPAIR AREA USING NON SHRINK GROUT. PROFILE OF GIRDER MAY NEED TO BE INCREASED AROUND REPAIR AREA TO PROVIDE PROPER COVER.
- AFTER GROUT HAS CURED PLACE TRAFFIC BACK ON BRIDGE OR REPAIRED AREA OF BRIDGE.

PROJECT NO. **15BPR.49**
WAKE COUNTY
 BRIDGE NO. **910240**

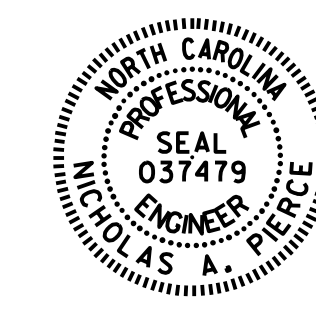

STATE OF NORTH CAROLINA
 DEPARTMENT OF TRANSPORTATION
 RALEIGH
 STANDARD
PRESTRESSED CONCRETE GIRDER REPAIR DETAILS

ASSEMBLED BY: N.A. PIERCE DATE: 03/2019
 CHECKED BY: D.A. CANTRELL DATE: 11/2021
 DRAWN BY:
 CHECKED BY:

DOCUMENT NOT CONSIDERED FINAL UNLESS ALL SIGNATURES COMPLETED

REVISIONS						SHEET NO.
NO.	BY:	DATE:	NO.	BY:	DATE:	TOTAL SHEETS
1			3			74
2			4			